



# Project Information Document (PID)

---

Concept Stage | Date Prepared/Updated: 17-Jun-2019 | Report No: PIDC27031

**BASIC INFORMATION****A. Basic Project Data**

Country China	Project ID P171064	Parent Project ID (if any)	Project Name Hainan Health Sector Reform Project (P171064)
Region EAST ASIA AND PACIFIC	Estimated Appraisal Date Feb 03, 2020	Estimated Board Date Jun 19, 2020	Practice Area (Lead) Health, Nutrition & Population
Financing Instrument Investment Project Financing	Borrower(s) People's Republic of China	Implementing Agency Hainan Provincial Health Commission	

**Proposed Development Objective(s)**

The Project Development Objective is to contribute to improving the quality and efficiency of primary health care services in Hainan.

**PROJECT FINANCING DATA (US\$, Millions)****SUMMARY**

<b>Total Project Cost</b>	236.00
<b>Total Financing</b>	236.00
<b>of which IBRD/IDA</b>	200.00
<b>Financing Gap</b>	0.00

**DETAILS****World Bank Group Financing**

International Bank for Reconstruction and Development (IBRD)	200.00
--	--------

**Non-World Bank Group Financing**

Counterpart Funding	36.00
Local Govts. (Prov., District, City) of Borrowing Country	36.00



Environmental and Social Risk Classification

Substantial

Concept Review Decision

Track II-The review did authorize the preparation to continue

Other Decision (as needed)

## B. Introduction and Context

### Country Context

1. China has made remarkable gains in overall health outcomes in the last three decades, further reinforced by the launch of a round of major health reforms in 2009. With China's rapid socioeconomic development, however, new systemic challenges have emerged in the health sector, including : (a) a rapidly aging population; (b) a hospital-centric, fragmented and volume-driven health system not well-suited to address the high and increasing burden of non-communicable diseases (NCDs), such as diabetes and hypertension; (c) financing incentives that result in the over-production of health services, driving up costs especially for the poor and vulnerable; (d) limited capacity for the delivery of quality primary health care (PHC) services; and (d) insufficient coordination among institutional actors. In the past decade, growth in health spending per capita, at 15.8 percent per year, was higher than growth in GDP per capita at 11.4 percent per year and if unchecked this gap is likely to continue in the coming decades.

2. China also embarked on a second phase of national health reforms, as articulated in the Healthy China 2030 Plan, the Health Sector Development Plan and the 13th Five Year Health Reform Plan. Eleven Provinces spearheaded the reforms, and the World Bank supported Government's agenda to scale up these reforms under "China Health Reform Program for Results (PforR)" in Anhui and Fujian Provinces. While some progress has been made in improving risk protection, the reforms have not been able to stop the flow of patients bypassing primary health care services for higher level hospital care, which continues to impose a high financial burden especially for the poor. In addition, vast parts of China are still catching up with the expanding reform process initiated in 2015. The slow-down of the economy has increased the urgency to bring greater efficiency in health service delivery and the need for even deeper reforms; unless the rest of China catches up and accelerates the reform priorities, inequities will continue to rise. Hainan, which equates more with China's western poorer provinces in economic development, is a province that was not included as one of the early reformers. Hainan's special status and greater freedom for innovations, however, could make it a front runner on how reforms can be deepened, and leap frogged.

### Sectoral and Institutional Context

3. Hainan is one of the smallest and newer Province of China and consists of a main island and various small islands, with a population of around 9.25 million. It has 19 Prefectures/Counties, 6 of which are Minority Autonomous Counties. Over 18 percent of the population belong to minority groups, with the Li Minority Group accounting for around 16 percent; 4 Counties are on the Government's list of Counties suffering extreme poverty, and half of the Minority Autonomous Counties are on the list. Around 8.14 percent of the residents are aged 65 and above, more than 3 percent lower than that of the national average. Due to its tropical climate, Hainan attracts a larger number of the elderly from other Provinces (estimated at around 1.31 million in 2017) to live during the winter; this number is expected to grow. This is also an additional burden to Hainan's health service delivery system.



4. In April 2018 the State Council issued the “Guiding Opinions on Supporting Hainan in Comprehensively Deepening Reform and Opening-up”, granting Hainan special status and freedom to pilot innovative reforms. Despite this high-profile status, the economic development in Hainan lags most of China. In 2017, Hainan’s GDP per capita was 48,430 RMB (1 RMB = US\$0.15), compared to the national average of 59,660 RMB; disposable income per capita per day for urban and rural residents was 84 and 35 RMB, respectively.

5. Life expectancy at birth and healthy life expectancy performance in Hainan ranks in the middle range among the Provinces. Data from 2017 indicates that the maternal mortality ratio was higher than the national average, whereas under-five, infant, neonatal mortality rates were lower than the national average. The vaccination coverage for children is almost universal, reaching 99 percent for tuberculosis, poliomyelitis, diphtheria, tetanus and pertussis vaccine, measles, and hepatitis B. The prevalence of NCDs as well as the disease burden in Hainan, similar to other parts of China, has been rising rather fast, particularly diabetes; however, the burden of cardiovascular disease and cerebrovascular disease were relatively low, when compared to other Provinces.

6. Hainan spends more on health than the national averages provides lower quality services, lacks critical staff delivering primary health care (PHC) and has poorer health outcomes. Total health expenditure in Hainan was 30.3 billion RMB in 2016, accounting for 7.48 percent of its GDP, over 1 percent higher than the national average. Compared to other Provinces, a larger portion of total health expenditure was financed by the Government, whereas a smaller portion was paid by individuals’ out-of-pocket (OOP). Hainan’s current provider payment system is fragmented and does little to encourage/support new care models that improve care coordination or develop services for patients with complex health needs that span across levels of care (e.g., NCD patients or patients with multiple morbidities). The health system is facing a severe shortage of qualified PHC professionals. In 2017, Hainan had 2.26 Physicians (including Assistant Physicians) and 3.08 registered nurses per 1,000 population, however, only 33.7 percent of Physicians and Assistant Physicians and 25.9 percent of Registered Nurses work at the primary care level. There are only 1.22 GPs per 10 thousand population, which is two-thirds the national average.

7. The health service delivery system is hospital-centric: 20.2 percent of outpatient services and 41.9 percent of inpatient services were provided by 17 tertiary hospitals. Between 2007 and 2017, the number of hospital beds increased from 2.5 to 4.5 beds per 1,000 population. In 2017, the occupancy rate was 73.7 percent and average length-of-stay was 8.5 days. These factors have compounded the existing shift in human resource capacity towards higher level facilities. Quality of care in Hainan is also on the lower end in comparison to other provinces. Among the 31 provinces, Hainan fell to the last position in the national performance ranking of the Basic Public Health Service (BPHS) Program in 2016. More attention needs to be directed to improving the process and outcomes of care; for example, there are substantial gaps in the management of hypertension and diabetes, conditions that can lead to disabling or life-threatening complications. A community-based national screening project of 1.7 million participants aged 35-75, which Hainan participated in, found that 45 out of 100 people had hypertension, of whom 20 were aware of their diagnosis, 13 took prescribed antihypertensive medications, and only 3 had achieved control; the finding for diabetes was similar. Poor provider care and high practice variation likely contribute to these diagnostic gaps, yet these metrics have not been collected in Hainan province.



8. On average, the poor<sup>1</sup> living in the rural areas of Hainan had relatively poorer health status and much more financial burden<sup>2</sup>. The poor disproportionately utilize the primary care services with 18.3 percent of them seeking care in the past 2 weeks; 78.2 percent of which were at the primary care level; 6.2 percent being hospitalized in the past one year giving a within-County hospitalization rate of around 70 percent. Data also indicates that illnesses led to significant financial burden, particularly for the poor in the rural areas. The Out of Pocket (OOP) expenditure per admission was around 6,500 RMB, accounting for over 42 percent of household disposable income.

9. Hainan has significant room to increase the efficiency of health spending and the potential to strengthen primary health care (PHC). The three-tier rural health network was established when roads, cars, cellphones and computers were not so widely prevalent.; improved road and train transport and mobile communication have narrowed the health service gaps. Hainan's improved connectivity has made most of the primary care, as currently delivered, redundant. A strong/high capacity PHC system, that cuts across administrative boundaries, delivered through team-based approaches and based on the actual epidemiological and demographic profile, could improve health outcomes and respond efficiently to the needs of aging populations and the growing burden of NCDs. At the individual provider level, incentivizing provider-level behavior change and improving the care for the growing burden of NCDs has been shown to be a cost-effective and rapid means of improving a country's health.

#### Relationship to CPF

10. The World Bank has established twin goals to anchor its overarching mission, and to galvanize international and national efforts in this endeavor, namely to: (a) end extreme poverty at the global level within a generation; and (b) promote shared prosperity (which is defined as a sustainable increase in the wellbeing of the poorer segments of the society). This Project will contribute to the achievement of both these goals by improving health service delivery with a focus at the primary care level. This will directly benefit the vulnerable groups with improved access to affordable and high quality of care, and will eventually improve people's health, financial protection, and satisfaction.

11. The proposed Project thus fits well under the World Bank's overall engagement in the country as stated in the Systematic Country Diagnostic (SCD), which will inform the World Bank's 2018-2022 Country Partnership Framework currently under preparation. As identified in the current SCD, China's current service delivery system is hospital-centric, fragmented, and volume-driven, which entail a cost not only to the health system but also to patients, particularly the poor. Further the Capital Increase Package had highlighted the importance of prioritizing development of strong institutions for sustainable economic and social development. The proposed project aligns with this selectivity criteria by the fact that if a) China does not complete its health care system reform, cost will skyrocket and it will primarily hurt the poor, 2) the complex institutional change needed to complete the reform agenda needs World Bank support because it involves complex institutional change and global knowledge 3) the World Bank will gain valuable insights on how to design health system support projects that address spreading NCD epidemics that increasingly threaten gains in humanity health.

<sup>1</sup> Households with income in the lowest 20 percent.

<sup>2</sup> National Health Service Survey (2018).



### C. Proposed Development Objective(s)

**Note to Task Teams:** The PDO has been pre-populated from the datasheet for the first time for your convenience. Please keep it up to date whenever it is changed in the datasheet. *Please delete this note when finalizing the document.*

The Project Development Objective is to contribute to improving the quality and efficiency of primary health care services in Hainan.

#### Key Results (From PCN)

12. There are five PDO indicators identified within the Program, capturing both supply and demand side elements of the health system goals of improving comprehensive access, quality and efficiency. PDO indicators being considered are as follows:

- Increase in rates of individuals who are under optimal blood glucose control (using an HbA1c measure) among patients diagnosed with Diabetes Type II;
- Increase in rates of individuals who are under optimal hypertension control in the last six months among patients diagnosed with hypertension;
- Improvement in physician compliance with evidence-based practice recommendations for management of priority high burden conditions (e.g., maternal health, hypertension, diabetes) at PHC level;
- Decline in hospital admissions for ambulatory sensitive conditions (e.g., asthma, chronic obstructive pulmonary diseases, congestive heart failure or diabetes) among people aged 15 years and above; and
- Increase in General Practitioners in positions at Township Health Centers (TH)/Community Health Centers (CHC).

### D. Concept Description

13. Improving Hainan's health system performance for access, quality, coordination and efficiency will require health services delivery transformation, and building a health system around high-quality PHC - the lynchpin for people centered integrated care. A high-quality PHC system must offer patients easy access to care, provide a continuum of care appropriate to the needs and promote a healthy lifestyle. This requires that PHC facilities remain geographically and physically accessible, the PHC team remains available to meet the urgent care needs of the patients, and that patients can connect with their multi-disciplinary team in a variety of ways, such as meeting in person, communicating by telephone or internet-based applications. Person-centric ensures care plans and protocols align with an individual's unique health care needs and formal programs of patient engagement and tools for self-management help to motivate healthy behavior change and involve the patient in his/her care at home and in the community. This service delivery transformation towards an integrated PHC will require revamping the model of care, how providers are organized, services are managed, and strengthening the quality of care. It will need concomitant system changes to how the PHC is financed, staffed and mobilizing information systems. The proposed operation will improve climate resilience of the health sector by contributing to technical and institutional capacities of the Hainan health care system, including improving its ability to respond to climate-related health risks.

14. Hainan's administrative flexibilities allow for deeper institutional and regulatory reforms to further advance the development of a people centered integrated care system. In driving even deeper reforms towards people center



integrated care his Project will support Hainan to (a) consolidate and optimize the PHC service delivery system so that there are fewer, better equipped, appropriately staffed and more integrated facilities; (b) break down the silos that exist between medical and public health programs; (c) strengthen the quality of care at the primary care level through improved measurement, feedback loops, and aligned incentives; (d) develop high quality revitalized PHC work force with new roles for outreach and care coordination; (e) improve strategic purchasing to ensure evidence-based best buys, paying for quality and reducing inequities among insurance programs; and (f) harness information technology (IT) to integrate care, enhance quality and strengthen management. By providing additional focus on implementation support, it will ensure these ambitious reforms are implemented with rigor, have the best expertise and evidence, build capacities for innovations, and support the knowledge generation and sharing of lessons with other, poorer Provinces for country-wide adaptation. The Theory of Change supporting the Project Development Objective, to improve the quality and efficiency of primary care services in Hainan, is illustrated in the following table.



Table 1 The Theory of Change

Result Areas	Activities	Outputs	Impact
<b>Building High Quality Value Based Service Delivery</b>	Re-optimizing to make PHC the first point of contact	<ul style="list-style-type: none"> <li>Strengthen TH/CHC as pivot of health system</li> <li>Build Family Doctor teams</li> <li>Empanel communities</li> <li>Build a dual referral system</li> <li>Integrate financing and pay through capitated budgets</li> </ul>	<ul style="list-style-type: none"> <li>Increase in rates of diabetics under control</li> <li>Increase in hypertensives under control</li> <li>Increase in compliance of evidence-based practices for NCD management</li> <li>Decrease in hospital admissions for ambulatory care sensitive conditions</li> </ul>
	Reorganizing services and management	<ul style="list-style-type: none"> <li>Implementation of BPHS Package strengthened (especially aged care services) and aligned with Medical Care</li> <li>PHC Integrated Management Teams established</li> <li>Incorporate disease control system into PHC</li> <li>County hospitals consolidated for specialized services</li> </ul>	
	Strengthening quality of primary care	<ul style="list-style-type: none"> <li>Quality Monitoring Team in Province established</li> <li>Roll out Clinical Protocols and Integrated care pathways for NCDs</li> <li>Enhance measurement of quality of care at PHC and feedback loops.</li> <li>Patient satisfaction measures introduced</li> <li>Financial incentives included for strengthening quality</li> </ul>	
<b>Addressing the System Building Blocks for Value Based Care</b>	Realigning incentives in purchasing and provider payment	<ul style="list-style-type: none"> <li>Benefit package streamlined and includes outpatient department/preventive care</li> <li>Purchasing for quality weighted services</li> <li>In equities between insurance schemes reduced and risk pooling at Provincial level initiated</li> <li>Prospective provider payment methods rolled out</li> </ul>	<ul style="list-style-type: none"> <li>Percent of reimbursement that include quality weightages</li> </ul>
	Developing qualified and motivated work force	<ul style="list-style-type: none"> <li>Reconfiguring human resources to optimized regional service delivery</li> <li>Continuous professional development through online accreditation program initiated for Assistant Physicians/ GPs</li> <li>Performance measurement for Family Doctor teams (including implementation of BPHS) and link with performance bonuses</li> </ul>	<ul style="list-style-type: none"> <li>Increase in GP availability in poor counties</li> </ul>
	Harnessing IT for integrating care and empowering patients	<ul style="list-style-type: none"> <li>Integrated information systems (population and hospital) established to provide comprehensive solutions for PCIC</li> <li>Primary care information platform commissioned in all PHC facilities</li> <li>Institutions/ Services strengthened with power of IT/big data:</li> </ul>	<ul style="list-style-type: none"> <li>Integrated patient information system established</li> </ul>





Result Areas	Activities	Outputs	Impact
		<ul style="list-style-type: none"> <li>▪ Insurance – Big data review of prescription practices and anti-fraud</li> <li>▪ Online training for continuous professional development</li> <li>▪ League Tables created for TH/CHC performance</li> </ul>	
<b>Enhanced Implementation</b>	Technical and financial resources deployed	<ul style="list-style-type: none"> <li>• Implementation research supported</li> <li>• Domestic and International expertise harnessed</li> <li>• Learning and dissemination activities implemented</li> <li>• Information, communication geared towards patient behavior</li> </ul>	<ul style="list-style-type: none"> <li>• Project decisions guided by implementation research</li> <li>• Project contributes to learning events</li> </ul>

**Component 1: Building High Quality and Value Based Service Delivery System**

15. Hainan’s health care is characterized by over-provision of inpatient hospital care, which could be provided effectively and much more efficiently in PHC facilities; uneven and inadequate quality of care; strong incentives to provide medically unnecessary services; rising costs and poor value for money; and disappointing health outcomes. With their enhanced infrastructure, technological edge and human resource capacity, hospitals draw patients away from lower levels of care, even further undermining the role of PHCs. Any attempt to create an effective integrated tiered delivery system will require fundamental changes in how services are organized and delivered, at both the hospital and the PHC level, in a system in which there is room for marked improvement in quality.

16. Since 2015 national efforts in strengthening integrated (tiered-care) service provision have included (a) capital investments and capacity building at the PHC level; (b) national policies that promote gatekeeping, referral systems, and vertically integrated networks (such as medical alliances); and (c) payment reforms to improve financing and provider incentives at lower levels of care. However, these efforts have not stopped the declining PHC utilization; handicapped by continued growth of hospitals, duplicative and redundant institutional structures and roles, weak human resource capacities, and continued poor quality of care. Hainan with its special status will seek to achieve this recalibration towards PHC by building it bottom up, cutting through administrative and geographical boundaries, dismantling and integrating institutions, redefining roles and responsibilities and using advances in technology to deliver a high quality and value-based health delivery system.

17. **Re-optimizing to make PHC the first point of contact:** Optimizing the health system and building health care around high-quality PHC will be the heart of the Project. The TH in rural areas/CHCs in urban areas, manned by smartly organized multidisciplinary teams of GPs, nurses and para-medicals, and retrained village doctors as “care coordinators”, will work with robust information systems and communication tools to deliver integrated care. With a focus on addressing primary needs, maintaining health and preventing illness, the TH/CHCs will host the new Family Doctor Team acting as the gateway to higher levels of care, including County



and Prefectural level hospitals. Community members will be empaneled at their geographically closest TH/CHCs with options for moving to other preferential teams. Village Doctors re-trained as care coordinators will provide outreach, preventive and promotive services and basic curative care and their performance will be measured against outcomes achieved. A Primary Care Integrated Management Team, comprising of members from the Chinese Center for Disease Control and Prevention (CDC), Insurance agency and other allied services will provide the leadership, oversight and fund management. A more streamlined financing system that integrates the Public Health Equalization Funds and Insurance Financing and paid through Global Capitated Budgets will finance this level of the system. County level care will be consolidated to reduce duplication and will provide specialized outpatient and inpatient services and become part of the Medical Alliance which will be led from the PHC Integrated Management Teams. County Hospitals will in turn link with regional and Provincial-level hospitals.

18. These deep institutional reforms will be sequentially phased starting from the PHC service delivery level at TH/CHC and eventually incorporating the County and Region. Primary care doctors will shed some of their heavy administrative mandates creating space for more care coordination to work as a part of a multidisciplinary teams which will include the disease control and public health specialists. It will require revising and reframing roles, laws, functions, reporting lines and financing mechanisms. Particular domains for service delivery engagement will include: (a) repositioning PHC as the first point of contact; (b) reorganizing PHC services and management; (c) continuous quality improvement; (d) family- and community-oriented care provision; (e) health outcome oriented financial incentives; and (f) raising awareness of patients for improved health care seeking behavior.

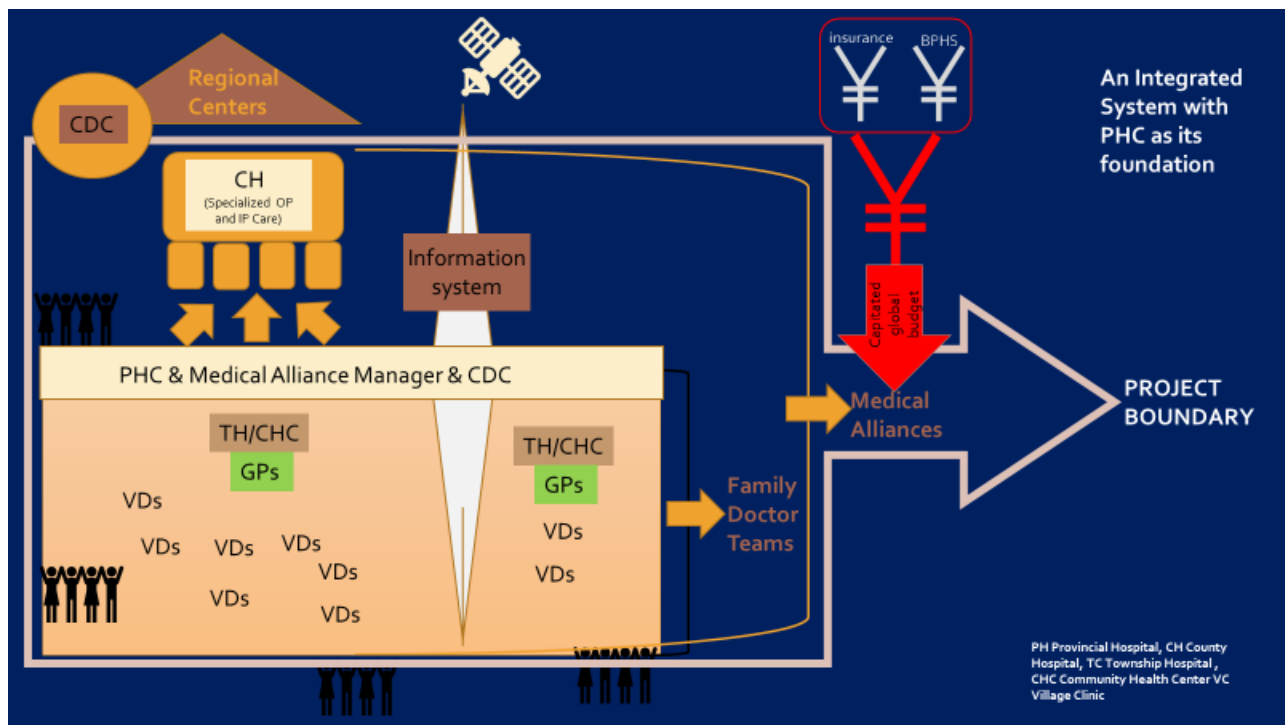



19. The proposed Project will focus on strengthening the TH/CHC level, so that care can be provided around the needs of people, and further emphasize their role in the integrated care system. As shown in the picture above, the TH/CHC will gradually become the foundation of the health care delivery system in Hainan, with the following features:

- (a) The TH/CHC will provide most day-to-day health care services to the people in the catchment area, through strengthened family doctor teams, which normally consist of physicians (GPs), physician assistants, nurses, and public health specialists;
- (b) The TH/CHC will be responsible for managing all the family doctor teams through a results-oriented performance management system to promote better health management and maintenance (village doctors will be required to join one of the family doctor teams);
- (c) The family doctor teams will provide basic curative services, mostly outpatient or minor surgeries, and preventive and promotive services, including the 14 service items listed in the BPHS program, ensuring round the clock availability of services;
- (d) The TH/CHC will be responsible for “health profiling” of citizens in their catchment areas, through family doctor teams by conducting population-based risk screening, and unique ID-enabled database tracking;
- (e) The citizens within the catchment areas of a Township or community will choose between family doctor teams during the empanelment process, and sign up for add-on services on top of basic services provided by the Government;
- (f) The TH/CHC will coordinate a dual referral system to ensure accurate and speedy transfer of patients to the appropriate specialists at the County Hospitals and Regional Health Centers;
- (g) The financing for health services will be managed at the TH/CHC, including from the health insurance fund and other funding resources for earmarked programs. The health care security administrations will pay the TH/CHC management with a capitated global budget, according to the empanelment records. The TH/CHC management will, in turn, pay County level or regional health centers through prospective payment methods including diagnosis related groups; and
- (h) The improved remuneration becomes attractive so as to retain family doctor teams at the PHC levels.

20. **Reorganizing services and management.** Recalibrating the system towards a strengthened PHC will require consolidation of the services, integrating institutions and realizing new roles. The Project will support the building of a strengthened and empowered Integrated Primary Care Management Team, integrating the population’s health within the PHC continuum and consolidation of County level hospitals towards specialist outpatient and inpatient care as follows<sup>3</sup>:

- (a) Strengthening implementation of BPHS Package, which is a nation-wide earmarked program that provides PHC services to all the residents, and retargeting this as part of the people centered

---

<sup>3</sup> This will require concomitant changes to financing, how the human resources are developed, and deployment of IT, which are supported under Component 2.



integrated care continuum for NCDs and aged care will be a key strategy to further value-based care. The three levels of Government together accumulate a total of RMB 55 (~US\$ 8) per capita each year, and expenditures are earmarked to a list of 14 public health activities. Seven of these relate directly to NCDs and aged care, focused largely on prevention and keeping communities healthy. The Project will aim to revisit the roles of village doctors in providing care coordination, Family Doctors in preventive and curative care planning, and delivery, developing service protocols and standards and monitoring implementation of the five guarantees<sup>4</sup>. Elements pertaining to aged care, NCD management and behavior change packages will be prioritized.

- (b) A key innovation will be incorporating the public health and disease control system (i.e. the CDCs) at the Prefecture and County level into the PHC service delivery system by refining their roles and integrating their tasks and financing. Although a comprehensive and technically sound system, that runs from national, Provincial, Prefecture through County levels, and dedicated to promoting public health, the centers for disease control are increasingly functioning as a silo, supported by earmarked public financing. This not only results in resource inefficiency, but they are also becoming irrelevant in guarding people's health outcome and controlling NCDs. The Project aims to bring these teams back to their core mandates of disease control by: (i) working in multidisciplinary family doctor teams that are managed by the TH/CHC; (ii) incorporating the fragmented CDC programs into the major BPHS program in terms of tasks and financing; (iii) redefining the tasks of core CDC staff by shifting their major duty away from administrative tasks towards empowered public health functions.
- (c) The to-be established new PHC Integrated Management Teams will take the lead role in managing care coordination, including management of the TH/CHC and leading the medical alliance<sup>5</sup>. Drawn from technical and managerial staff from Township, County, CDC, IT experts and insurance agencies, this team, led by a PHC Director, will (i) provide the oversight, leadership and quality assurance for the population's health and primary care; (ii) hold capitated global budgets for its empaneled members; (iii) lead medical alliances with County Hospitals; and (iv) manage payments for specialist hospital outpatient and inpatients through diagnosis related groups.
- (d) County Hospitals form the apex of the primary care system and will focus on specialist care and supporting the primary care in patient management, and capacity building. Using telemedicine and an enhanced information system, specialists will track patients, provide clinical advice and support family doctors in care. Consolidation of hospitals facilities, specialized centers for diagnostics and facilities for day care surgeries will aim to streamline secondary level care. The County level will in turn be linked with regional centers for higher/tertiary care.

**23. Strengthening Quality of Care and Focus on Outcomes:** Strengthening Quality of care is an important building block for improving value, standardizing clinical practice, minimizing practice variation and costs associated with unnecessary clinical care. While much focus has been laid on the quality at hospital levels,

<sup>4</sup> For the rural extremely poor, government guarantees food supply, clothing, medical care, housing, and funeral

<sup>5</sup> Medical alliance consists of the three-tier health service providers, a county level hospital (often the lead hospital) and includes several township health centers and several village clinics in the catchment area of the township



quality of primary care has not been sufficiently measured, tracked and incentivized. The project will support the establishment of

- (a) A system for routine, serial collection of quality of care data at primary level including patient experiences and patient outcomes and continuous feedback to providers on quality gaps to enable continuous quality improvement.
- (b) Roll out clinical protocols and integrated care pathways for priority NCDs, multiple chronic conditions and population health services.
- (c) Implement performance linked payment mechanisms and facilitate strategic purchasing of quality both at the insurance level and for Basic Public Health Service Package implementation.
- (d) Establish a provincial level Quality Monitoring structure and mechanism to ensure coordinated efforts to measure, track and improve quality in the province.
- (e) Improve transparency of provider performance by creating an online dashboard of performance of TH/CHC.

## **Component 2: Addressing the System Building Blocks for Value Based Care**

21. Improving the quality and efficiency of health care in Hainan will necessitate the Provincial Health Commission; the Prefecture, County and Township service delivery units and the Provincial Health Security Agency (PHSA) to work together to improve the health of their local population by integrating services and tackling the causes of ill health. It marks a shift away from policies that have encouraged competition and cost containment towards an approach that relies on collaboration. It will require addressing behaviors, incentives and structures and represents a different way of working – the emphasis being on places, populations and systems, rather than purely technical roles. To enable this transition the Project will: (a) realign incentives in purchasing and provider payments; (b) develop a qualified and motivated and fit for purpose workforce; and (c) harness the power of IT for delivering high quality integrated care.

22. ***Realign Incentives in Purchasing and Provider Payment:*** In line with national structures, Hainan established the new Provincial Health Security Administration (PHSA) in 2019. The PHSA mandate is to consolidate the management of all basic medical insurance schemes (New Cooperative Medical Scheme (NCMS) and Urban Resident Basic Medical Insurance (URBMI), and Urban Employee Basic Medical Insurance-UEBMI), maternity insurance scheme and medical aid scheme. The new PHSA will also be responsible for pharmaceutical and medical services pricing; these functions were under the jurisdiction of four different line departments within the Provincial Government. Despite the institutional reform which addressed some fragmentation issues in the insurance management, the existing inequities between different basic medical insurance schemes are significant: UEBMI and URBMI pool at Provincial level, while NCMS pools at Prefectural/County level; the OOP payment rate for inpatient care ranged from 26 percent for UEBMI to 43 percent for NCMS in 2017. The purchasing of health care services is still passive, with little incentive embedded in the current provider payment system for improving quality of care and population health, and Hainan further lags in introducing prospective payment methods. Due to the high prevalence of fraud in outpatient settings, most of the outpatient services are not covered, which incentivizes patients to seek unnecessary inpatient care. It is worth noting that the financing for medical care services and public health services is fragmented: medical care services are financed



by basic medical care insurance schemes whereas public health services are financed by earmarked public health service funds.

23. The Project will support Hainan's PHSA to become a strategic purchaser of high-quality value-based care, driving the health system to be more efficient, outcome driven, and responsive to increasing needs of the population. Key results areas to be pursued will include (a) full merger of the URBMI and NCMS; (b) upgrading risk pooling to the Provincial level; (c) piloting prospective payment methods in all schemes including population-based payment (capitated global budget) for medical alliances, bundled payment for selected conditions such as diabetes, pay-for-quality payment to improve quality of care; (d) expanding coverage to general outpatient care and preventive care for all schemes, particularly those treated at PHC level; (e) setting up a Provincial-wide health insurance management system and conduct periodic fraud assessments; and (f) channeling capitated BPHS funds into basic medical insurance funds.

24. ***Develop a Qualified and Motivated and Fit for Purpose Workforce:*** Despite efforts in strengthening human resources for primary care in the past 10 years, through implementing GP, Assistant GP and GP Transfer Training Programs and incentivizing qualified GPs to work in the primary care institutions, the availability of GPs at the PHC institutions in Hainan is below the national average. Further there is little in-service training, poor supervision and performance management leading to a low skilled and low motivated workforce. A qualified and motivated work force will be key for a strengthened primary care system and building value-based care. Maintaining such a workforce will require serial measurement of provider quality, coupled with serial feedback and education to drive continued improvement.

25. The Project plans to take a systematic approach in addressing the identified gaps in human resources for health at Hainan's primary care level. The plan is to tackle the issues in the following three dimensions: (a) reduce the quantitative gaps of PHC doctor shortages through expanded "5+3" and "3+2" training programs, as well as the enhanced ongoing GP transfer program; (b) improve the skills and clinical capacities (quality) of the newly trained PHC doctors and existing primary care workforce through improved training curriculum and better integrating clinical and health promotion skills needed for PHC practice. The TH/CHC clinical and managerial personnel will be supported to adapt to new demands for working collaboratively in a multidisciplinary team, through on-the-job training and clinical practicums and a cohort of trainers will be built for bringing about sustainable improvement; and (c) implement institutional reforms for job placement and retention (staffing) of the primary care doctors, through packaged incentives, head-count quota pooling, senior nurse practitioners placements, and career development pathways. As noted in para 26 PHC staff will be supported on the job through enhanced measurement and supervision and recognition and awards for results achieved.

26. ***Using IT for Delivering High Quality Integrated Care:*** Hainan, as a well contained island Province, brings many unique opportunities to harness the power of technology and the internet for "Smart" health service delivery. A web enabled platform can support integrated service provision and improve resource sharing and allocation. Furthermore, these integrated service platforms can bring hospitals, patients, and social health insurance agencies to streamline the procedure of medical bill settlement. The Hainan Health Commission





(together with Provincial Department of Industry and Information Technology, and Department of Finance) are developing a plan to build a primary care health information system (with an investment of RMB 130 million). The system plans to cover all the THC, CHC and Village Clinics Province-wide, with six major components/modules, including the public health service, basic health service management, service coordination, pharmaceutical, payment, as well as PHC M&E.

27. Working with the above PHC information initiative, the Project will support the (a) development of a Provincial level health information exchange platform for medical and primary care information exchange; (b) building electronic health records and linkages between hospital information and the primary health information system; and (c) incorporate the power of IT applications in insurance fund management, big data analysis and human resource training. Over the Project implementation period, the health information system in Hainan will play a synergistic role for care integration, not only across different specialties of medicine and levels of health facilities, but also as a foundation for care provision and financing with other sectors, such as civil affairs and health care security. For example, the establishment of high quality and dynamically updated health records could become the foundation for needs assessment for rationing of long-term care and medical care services for the elderly in Hainan, and the over one million elderly migrants who move to Hainan during the winter.

### **Component 3: Implementation Support**

28. Hainan lags other Provinces in reform implementation and while this provides new opportunities to fast track implementation based on lessons from other reform Provinces, it also means enhanced technical support will be needed to support implementation and take to scale these ambitious reforms. Three elements are envisaged as part of the enhanced support, including (a) technical assistance (TA) to roll out reforms and support Project management functions; (b) capacity building for implementation research; and (c) learning and dissemination, especially with other poorer Provinces, of reform lessons.

29. The Project will support the Department of Healthcare Reform (DHR) of the National Health Commission (NHC) (also playing the roles as the Secretariat of the State Council Leading Group on Health Reform) and the National Health Security Agency's (NHSA) role as the steward of the sectoral reforms. The NHC and NHSA will support the institutional capacity building at the Provincial and local levels. The NHC and NHSA are also expected to contribute to the achievement of the PDO through implementation-oriented guidance, TA provided by national experts, introduction of systems for monitoring and validating progress, and assessing implementation from a "big picture" and system perspective. Finally, both these institutions are expected to support Hainan in their efforts to foster knowledge generation and sharing, in the process of scaling up reforms, to other Provinces in China, and other developing countries facing similar issues.



Legal Operational Policies	Triggered?
Projects on International Waterways OP 7.50	No
Projects in Disputed Areas OP 7.60	No

### Summary of Screening of Environmental and Social Risks and Impacts

Targeting at the improvement of accessibility, quality and efficiency of primary health care services in Hainan Province, the investments considered under the project at this stage mainly include the strengthening and consolidation of Town Hospitals/Community Health Centers (THs/CHCs), health care financing reforms, capacity building of health care workforce, and establishment of integrated patient information system. The project will only support equipment procurement, capacity building and technical assistance activities without involving any civil works and thus will not result in any direct and significant environmental impact. However, with the operation of reoptimized primary health care services/associated facilities, there will be some downstream environmental issues to be considered, including use and disposal of hazardous chemicals, increased production of wastewater and medical waste, Occupational, Health and Safety risk of healthcare workforce in the primary health care system. Considering limited information currently available and lack of institutional capacity at the provincial and local levels on environmental and social risk management, the overall environmental risk is rated substantial at this stage and this rating will be further checked by appraisal. By recognizing these potential risks, more modern technology, more efficient processes, more targeted awareness campaign and better management system will be incorporated into the project design to minimize waste streams and OHS risks and to secure safe handling and disposal of hazmat. Further assessment on project-related environmental risks will be conducted along with the optimization of project design in relevance to the ESSs during preparation.

The investments under this project are expected to mainly focus on technical design to improve health services delivery transformation and building a health system around high quality primary care. The project components excluded any physical investment. Thus, no physical activities on sensitive locations will be considered. No civil works is involved and no land take is expected to be required. Therefore, there is no displacement impact and no significant adverse impact on local communities and ethnic minorities. No community workers will be used and no significant risks on labor and working conditions are envisaged due to the nature of the project.

Some concerns were identified during this stage regarding on how to use effective and appropriate stakeholder engagement approach to achieve the equal improvement for the most poor and ethnic minorities groups. The number and diversity of stakeholders and agencies to be involved in the project implementation, as well as the complexity of the required engagement process is dependent on the specific project activities yet to be defined. This may affect the potential risk level of the project failure in achieving equal healthcare services improvement to the vulnerable groups. Further technical design, a rapid poverty and social impact assessment to be undertake during the project preparation, as part of the ESMF development, and the initial stakeholder engagement would contribute to confirm the project complexity and its risk level.

Regarding borrower capacity and commitment, although the lack of previous experience of working with Bank policies, the Hainan PMO and implementation agencies have experienced health reform challenges in the past few years, which contributed to their management capacity development. In addition to that, it is important to consider the current context of a strong commitment from national and provincial level government on supporting the project. For these reasons, the overall social risk rating is considered substantial at this stage.





**Note** To view the Environmental and Social Risks and Impacts, please refer to the Concept Stage ESRS Document.

### CONTACT POINT

#### World Bank

Dinesh M. Nair  
Senior Health Specialist

#### Borrower/Client/Recipient

People's Republic of China

#### Implementing Agencies

Hainan Provincial Health Commission  
MaoGuo Wei  
Director  
weimaoguo1962@163.com

### FOR MORE INFORMATION CONTACT

The World Bank  
1818 H Street, NW  
Washington, D.C. 20433  
Telephone: (202) 473-1000  
Web: <http://www.worldbank.org/projects>

### APPROVAL

Task Team Leader(s):	Dinesh M. Nair
----------------------	----------------

#### Approved By

Practice Manager/Manager:		
Country Director:		

