

E4489 V4

5 Capitals  
Environmental & Management Consulting



NOORo II CSP Power Plant,  
Ouarzazate, Morocco  
Specific Environmental and Social Impact  
Assessment  
Volume 1



ACWA Power

March 2015

## Document Information

<b>Project</b>	NOORo II CSP Power Plant, Ouarzazate, Morocco
<b>Project Number</b>	1305/001/010
<b>Report Title</b>	Specific Environmental and Social Impact Assessment
<b>Client</b>	ACWA Power
<b>Project Manager</b>	Zeina Jokadar
<b>Project Director</b>	Ken Wade

## Document Control

Rev	Issue Date	Description	Author	Reviewed	Approved
1	31/08/2014	Draft	ZMJ CPM	KRW	KRW
2	19/12/2014	Draft	ZMJ CPM	KRW	KRW
3	27/03/2015	Final	ZMJ CPM	KRW	KRW

## Table of Contents

NON-TECHNICAL SUMMARY.....	XV
<b>1 INTRODUCTION.....</b>	<b>1</b>
1.1 General Background.....	1
1.2 Assessment Objectives.....	1
1.3 Report Structure.....	2
<b>2 POLICY, LEGAL AND ADMINISTRATIVE FRAMEWORK.....</b>	<b>3</b>
2.1 Requirements For Environmental Assessment.....	3
2.2 Standards and Guidelines.....	9
<b>3 PROJECT DESCRIPTION.....</b>	<b>28</b>
3.1 Key Project Objectives.....	28
3.2 Location of the Project Site.....	28
3.3 Site Condition and Land Use.....	31
3.4 Key Sensitive Receptors.....	34
3.5 Project Alternatives.....	36
3.6 Project Design.....	38
3.7 Main Complex Facilities.....	42
3.8 Construction Phase.....	50
<b>4 SESIA METHODOLOGY.....</b>	<b>53</b>
4.1 Introduction.....	53
4.2 Baseline Surveys.....	53
4.3 Impact Assessment Significance Criteria.....	54
4.4 Consultation Process.....	57
<b>5 SOIL AND GROUNDWATER.....</b>	<b>59</b>
5.1 Introduction.....	59
5.2 Methodology.....	60
5.3 Baseline.....	62
5.4 Sensitive Receptors.....	66

---

5.5	Construction Assessment .....	66
5.6	Operation Assessment.....	71
<b>6</b>	<b>WATER AND WASTEWATER MANAGEMENT .....</b>	<b>76</b>
6.1	Introduction .....	76
6.2	Methodology.....	76
6.3	Baseline .....	77
6.4	Sensitive Receptors .....	77
6.5	Construction Assessment .....	77
6.6	Operation Assessment.....	82
<b>7</b>	<b>AIR QUALITY .....</b>	<b>91</b>
7.1	Introduction .....	91
7.2	Methodology.....	92
7.3	Baseline .....	93
7.4	Sensitive Receptors .....	95
7.5	Construction Assessment .....	95
7.6	Operation Assessment.....	99
<b>8</b>	<b>NOISE AND VIBRATION .....</b>	<b>111</b>
8.1	Introduction .....	111
8.2	Methodology.....	111
8.3	Baseline .....	113
8.4	Sensitive Receptors .....	115
8.5	Construction Assessment .....	115
8.6	Operation Assessment.....	120
<b>9</b>	<b>SOLID AND HAZARDOUS MATERIALS .....</b>	<b>126</b>
9.1	Introduction .....	126
9.2	Methodology.....	126
9.3	Baseline .....	127
9.4	Sensitive Receptors .....	129



---

9.5	Construction Assessment .....	130
9.6	Operation Assessment.....	136
<b>10</b>	<b>STORMWATER MANAGEMENT.....</b>	<b>140</b>
10.1	Introduction .....	140
10.2	Methodology.....	141
10.3	Baseline .....	141
10.4	Sensitive Receptors.....	144
10.5	Construction Assessment .....	144
10.6	Operation Assessment.....	147
<b>11</b>	<b>ECOLOGY AND BIODIVERSITY .....</b>	<b>149</b>
11.1	Introduction .....	149
11.2	Methodology.....	150
11.3	Baseline .....	151
11.4	Sensitive Receptors.....	160
11.5	Construction Assessment .....	161
11.6	Operation Assessment.....	164
<b>12</b>	<b>SOCIAL AND ECONOMIC ISSUES .....</b>	<b>173</b>
12.1	Introduction .....	173
12.2	Methodology.....	173
12.3	Baseline .....	174
12.4	Sensitive Receptors.....	175
12.5	Construction Assessment .....	175
12.6	Operation Assessment.....	178
<b>13</b>	<b>TRAFFIC AND TRANSPORT .....</b>	<b>181</b>
13.1	Introduction .....	181
13.2	Methodology.....	181
13.3	Baseline .....	182
13.4	Sensitive Receptors.....	184

13.5	Construction Assessment .....	184
13.6	Operation Assessment.....	187
<b>14</b>	<b>CULTURAL HERITAGE AND ARCHAEOLOGY.....</b>	<b>189</b>
14.1	Introduction .....	189
14.2	Methodology.....	189
14.3	Baseline .....	190
14.4	Sensitive Receptors.....	192
14.5	Construction Assessment .....	192
14.6	Operation Assessment.....	194
<b>15</b>	<b>LANDSCAPE AND VISUAL IMPACT .....</b>	<b>195</b>
15.1	Introduction .....	195
15.2	Methodology.....	195
15.3	Baseline .....	195
15.4	Sensitive Receptors.....	197
15.5	Construction Assessment .....	198
15.6	Operation Assessment.....	200
<b>16</b>	<b>References .....</b>	<b>202</b>

## Tables

Table 2-1	Dutch Soil Standards .....	14
Table 2-2	Water Standards for irrigation .....	16
Table 2-3	Drinking Water Standards .....	17
Table 2-4	Domestic Discharge Standards .....	18
Table 2-5	Indicative Values for treated Sanitary Sewage Discharge .....	19
Table 2-6	Ambient Air Quality Standards ( $\mu\text{g}/\text{m}^3$ unless otherwise specified) .....	20
Table 2-7	Moroccan and IFC Maximum Permissible Emission Rates for Boilers .....	21
Table 2-8	IFC EHS General Noise Guidelines 9(at off-site receptor) .....	21
Table 2-9	Relative Assessment of Noise .....	22
Table 3-1	Centre Co-ordinates of the Project.....	29

---

Table 3-2 Predicted Water Consumption and Wastewater Generation.....	47
Table 3-3 Evaporation Pond Areas:.....	48
Table 4-1 Criteria for Magnitude of Impact .....	55
Table 4-2 Environmental Value of Receptor or Resource .....	55
Table 4-3 Criteria for Determining Significance of Effects .....	56
Table 4-4 Definition of Significance of Effects.....	57
Table 5-1 Soil Sample Locations.....	61
Table 5-2 Soil Analytical Results (mg/Kg) .....	64
Table 5-3 Soil and Groundwater - Receptor Sensitivity.....	66
Table 5-4 Soil, Geology and Hydrology – Magnitude of Construction Impacts .....	68
Table 5-5 Soil, Geology and Hydrology – Significance of Construction Impacts .....	68
Table 5-6 Soil and Hydrogeology – Residual Impacts – Construction Phase .....	71
Table 5-7 Soil, Geology and Hydrology – Magnitude of Operational Impacts .....	72
Table 5-8 Soil, Geology and Hydrology – Significance of Operational Impacts .....	73
Table 5-9 Soil and Hydrogeology – Residual Impacts – Operation Phase.....	75
Table 6-1 Sensitive Receptors.....	77
Table 6-2 Water Consumption during construction and commissioning (m <sup>3</sup> ) .....	78
Table 6-3 Water and Wastewater – Magnitude of Construction Impacts .....	80
Table 6-4 Water and Wastewater – Significance of Construction Impacts .....	80
Table 6-5 Wastewater – Residual Impacts – Construction Phase .....	82
Table 6-6 Estimate Peak Wastewater Production (m <sup>3</sup> /h) .....	85
Table 6-7 Evaporation Pond Areas.....	88
Table 6-8 Water and Wastewater - Magnitude of Occupation Impacts.....	89
Table 6-9 Water and Wastewater - Significance of Occupation Impacts.....	90
Table 6-10 Water and Wastewater– Residual Impacts – Occupation Phase .....	91
Table 7-1 Monitoring Coordinates.....	92
Table 7-2 Ambient Air Quality Monitoring Results for N2A1 .....	94
Table 7-3 Ambient Air Quality Monitoring Results for N3A1 .....	94

---

Table 7-4 Air Quality - Receptors sensitivity .....	95
Table 7-5 Air Quality – Magnitude of construction impacts.....	96
Table 7-6 Air Quality - Significance of Construction Impacts.....	96
Table 7-7 Air Quality – Residual Impacts – Construction Phase .....	98
Table 7-8 Auxiliary Boiler Exhaust Gases.....	99
Table 7-9 HTF Boiler Exhaust Gases .....	100
Table 7-10 Ullage System Emissions .....	100
Table 7-11 AERMOD predicted maximum concentration values .....	103
Table 7-12 Air Quality – Magnitude of Operation impacts .....	108
Table 7-13 Air Quality - Significance of Operation Impacts.....	108
Table 7-14 Air Quality – Residual Impacts – Operation Phase .....	110
Table 8-1 Noise sampling Coordinates .....	112
Table 8-2 Noise Monitoring Results, Day Time .....	114
Table 8-3 Noise Monitoring Results, Night Time .....	114
Table 8-4 Noise Monitoring Results, Average .....	114
Table 8-5 Noise/Vibration - Receptors sensitivity .....	115
Table 8-6 Noise Level of Anticipated site Plant/Equipment .....	116
Table 8-7 Construction noise levels in terms of distance from the source.....	117
Table 8-8 Noise and Vibration - Magnitude of Construction Impacts .....	118
Table 8-9 Noise and Vibration - Significance of Construction Impacts .....	118
Table 8-10 Noise and Vibration – Residual Impacts – Construction Phase.....	120
Table 8-11 RFP Noise Requirements.....	120
Table 8-12 Summary of Expected noise levels from the NOORo II CSP plant .....	121
Table 8-13 Noise and Vibration - Magnitude of Operation Impacts .....	124
Table 8-14 Noise and Vibration - Significance of Operation Impacts .....	125
Table 8-15 Noise and Vibration – Residual Impacts – Operation Phase.....	126
Table 9-1 Solid and Hazardous Waste - Receptors sensitivity.....	130
Table 9-2 Solid Wastes - Magnitude of Construction Impacts .....	132

---

Table 9-3 Solid Wastes - Significance of Construction Impacts .....	132
Table 9-4 Solid Waste– Residual Impacts – Construction Phase .....	136
Table 9-5 Wastes Streams and Estimated Quantities .....	138
Table 9-6 Solid Wastes - Magnitude of Operation Impacts .....	138
Table 9-7 Solid Wastes - Significance of Operation Impacts .....	138
Table 9-8 Solid Waste– Residual Impacts – Operation Phase .....	140
Table 10-1 Onsite water courses catchment area (m3/s) .....	142
Table 10-2 Stormwater - Receptor Sensitivity .....	144
Table 10-3 Stormwater – Magnitude of Construction Impacts .....	145
Table 10-4 Stormwater – Significance of Construction Impacts .....	145
Table 10-5 Stormwater – Residual Impacts – Construction Phase .....	146
Table 10-6 Stormwater – Magnitude of Operation Impacts .....	148
Table 10-7 Stormwater – Significance of Operation Impacts .....	148
Table 10-8 Stormwater – Residual Impacts – Operation Phase .....	149
Table 11-1 Ecology – Receptor Sensitivity.....	160
Table 11-2 Ecology – Magnitude of Construction Impacts .....	162
Table 11-3 Ecology – Significance of Construction Impacts .....	162
Table 11-4 Ecology – Significance of Construction Impacts .....	164
Table 11-5 Mortality rates by power plants and type of bird .....	165
Table 11-6 Cause of death by power plant.....	165
Table 11-7 Ecology – Magnitude of Operation Impacts .....	168
Table 11-8 Ecology – Significance of Operation Impacts .....	169
Table 11-9 Ecology – Residual Impacts – Operation Phase .....	172
Table 12-1 Socio-economic – Receptor Sensitivity .....	175
Table 12-2 Socio-economic – Magnitude of Construction Impacts .....	176
Table 12-3 Socio-economic – Significance of Construction Impacts .....	177
Table 12-4 Socio-economic – Residual Impacts – Construction Phase .....	178
Table 12-5 Socio-economic – Magnitude of Operation Impacts .....	180

---

Table 12-6 Socio-economic – Significance of Operation Impacts .....	180
Table 12-7 Socio-economic – Residual Impacts – Operation Phase .....	181
Table 13-1 Road Network in the Province of Ouarzazate in 2007 (Km) .....	183
Table 13-2 Traffic and Transport – Receptor Sensitivity .....	184
Table 13-3 Traffic and Transport – Magnitude of Construction Impacts.....	186
Table 13-4 Traffic and Transport – Significance of Construction Impacts.....	186
Table 13-5 Traffic and Transport – Residual Impacts – Construction Phase.....	187
Table 13-6 Traffic and Transport – Magnitude of Operation Impacts .....	188
Table 13-7 Traffic and Transport – Significance of Operation Impacts.....	188
Table 13-8 Traffic and Transport – Residual Impacts – Operation Phase .....	188
Table 14-1 Culture and Archaeology - Receptors sensitivity .....	192
Table 14-2 Culture and Archaeology – Magnitude of Construction Impacts .....	193
Table 14-3 Culture and Archaeology – Significance of Construction Impacts .....	193
Table 14-4 Culture and Archaeology – Residual Impacts – Construction Phase .....	194
Table 14-5 Culture and Archaeology – Magnitude of Operation Impacts .....	194
Table 14-6 Culture and Archaeology – Significance of Operation Impacts .....	194
Table 14-7 Culture and Archaeology – Residual Impacts – Operation Phase .....	194
Table 15-1 Landscape and Visual – Receptor Sensitivity.....	198
Table 15-2 Landscape and Visual – Magnitude of Construction Impacts.....	199
Table 15-3 Landscape and Visual – Significance of Construction Impacts.....	199
Table 15-4 Landscape and Visual – Residual Impacts – Construction Phase .....	199
Table 15-5 Landscape and Visual – Magnitude of Operation Impacts .....	200
Table 15-6 Landscape and Visual – Significance of Operation Impacts .....	201
Table 15-7 Landscape and Visual – Residual Impacts – Operation Phase .....	201
<b>Figures</b>	
Figure 3-1 Identified Sensitive Receptors .....	36
Figure 11-1 Wetlands identified as important for the Marbled Teal in N.Africa and the Middle East.....	158

Figure 11-2 Classification of wetlands identified as important for the Marbled Teal in N.Africa .....	159
Figure 11-3 Water use of Parabolic CSP plants by different cooling options .....	167
<b>Plates</b>	
Plate 3-1 NOORo II CSP location .....	29
Plate 3-2 Project Layout – General.....	30
Plate 3-3 Project Layout – Power Island.....	31
Plate 3-4 Sparsely vegetated plateau.....	32
Plate 3-5 Chaaba running through the site.....	33
Plate 3-6 Canyon to the west of the site .....	33
Plate 3-7 Village of Tasselmant, north-east of the site .....	34
Plate 3-8 Mansour Ed Dahbi Reservoir .....	35
Plate 3-9 Longitudinal Profile of the Platform .....	51
Plate 5-1 Soil Sample Locations .....	62
Plate 5-2 Site Soil Profile at Chaaba.....	63
Plate 5-3 Soil profile within the site.....	64
Plate 6-1 Water Use Diagram.....	83
Plate 6-2 Raw Water Process Cycle at NOORo II CSP (Unit m <sup>3</sup> /h).....	84
Plate 7-1 Monitoring Locations .....	93
Plate 7-2 Wind rose for Ouarzazate Airport (2014).....	102
Plate 7-3 Annual and 24-Hour Emission model for SO <sub>2</sub> - Cumulative .....	104
Plate 7-4 Annual and 1-Hour Emission model for NO <sub>2</sub> - Cumulative.....	105
Plate 7-5 8-Hour Emission model for CO - Cumulative .....	106
Plate 7-6 Annual mean and 24-Hour Emission model for PM <sub>10</sub> - Cumulative.....	107
Plate 7-7 Annual Emission model for Benzene - Cumulative .....	108
Plate 8-1 Noise Survey Location.....	113
Plate 8-2 Solar field preliminary noise map .....	122
Plate 8-3 Power Island preliminary noise map .....	123

Plate 9-1 Waste Hierarchy .....	129
Plate 10-1 Chaabas and Catchments within the Site.....	143
Plate 10-2 North and South Channel Discharge Point .....	147
Plate 11-1 Typical site ecological conditions .....	154
Plate 11-2 Vegetation grouped in the Chaabas channel.....	155
Plate 11-3 Small mammal or reptile burrow .....	156
Plate 13-1 Casablanca Harbour / Agadir / Ouarzazate (844 km, 9:26 minutes) .....	183
Plate 13-2 Access road intersection.....	185
Plate 14-1 Fort in Tasselmant .....	191
Plate 14-2 Burial site in Tasselmant.....	191
Plate 14-3 Area of potential archaeological interest to the northwest of the study area .....	192
Plate 15-1 Communication towers at the intersection of N10 and the site access road.....	196
Plate 15-2 Typical view of the site.....	197

## List of Abbreviations

Abbreviation	Meaning
ACWA Power	Arabian Company for Water and Power
AP	Action Plan
AGCE	Autorite Gouvernemental Charge de L'Environnement
ALARP	As Low As Reasonably Practicable
AP	Action Plan
As	Arsenic
AAQS	Ambient Air Quality Standards
BAT	Best Available Techniques
BMP	Best Management Practice
BOO	Build, Own and Operate
BOP	Balance of Plant
BS	British Standards
BTEX	Benzene, Toluene, Ethylbenzene, and Xylenes
CBD	Convention on Biological Diversity
CCR	Central Control Room



Abbreviation	Meaning
Cd	Cadmium
CDSI	The Central Department of Statistics and Information
CESMP	Construction Environmental and Social Management Plan
CEMS	Continuous Emission Monitoring System
CIA	The Central Intelligence Agency
CN	Cyanide
CNEIE	Committee National de EIE
CO	Carbon Monoxide
CO <sub>2</sub>	Carbon Dioxide
Cr	Chromium
CREIE	Committee Regional de EIE
Cu	Copper
DA	Degraded Airshed
CSP	Concentrated Solar Power
dB(A)	A-weighted decibels
dB(C)	C-weighted decibels
DCMS	Distributed Control and Monitoring System
EHS	Environmental, Health and Safety
ESMP	Environmental Management Plan
EMS	Environmental Management System
EPs	Equator Principles
EPC	Engineering, Procurement and Construction
EPFIs	The Equator Principle Financial Institutions
ESF	Electrical Special Facilities
FESIA	Framework Environmental and Social Impact Assessment
GDP	Gross Domestic Product
GHG	Greenhouse Gas
GIS	Geographic Information System
ha	Hectares
HCE	Heat Collector Element
HDI	Human Development Index
Hg	Mercury
Hm <sup>3</sup>	Cubic Hectometre
HTF	Heat Transfer Fluid
IFC	International Finance Corporation

Abbreviation	Meaning
Laeq	A-weighted Equivalent Continuous Sound Level
Lamax	A-weighted Maximum Sound Level
Lcpeak	C-frequency weighted Peak Sound Pressure
LEL	Lowest Explosive Limit
LP	Low Pressure
MASEN	Moroccan Agency for Solar Energy
MEMEE	Moroccan Ministry of Energy, Mines, Water and Environment
hm <sup>3</sup>	Million cubic meter
MSDS	Material Safety Data Sheet
MTA	Ministere de Tutelle de l'Activite
Ni	Nickel
NO <sub>x</sub>	Nitrogen Oxide
NO <sub>2</sub>	Nitrogen Dioxide
O <sub>2</sub>	Oxygen
OECD	The Organisation for Economic Co-operation and Development
OESMP	Operational Environmental Management Plan
O&M	Operation and Maintenance
PAH	Polycyclic Aromatic Hydrocarbons
Pb	Lead
PCOD	Project Commercial Operation Date
PM <sub>10</sub>	Particulate matter with an aerodynamic diameter of less than 10 micrometers.
PM <sub>2.5</sub>	Particulate matter with an aerodynamic diameter of less than 2.5 micrometers.
PPA	Power Purchase Agreement
PPE	Personal Protective Equipment
RFP	Request for Proposal
SCA	Solar Collector Assembly
SCE	Solar Collector Element
Se	Selenium
SESIA	Specific Environmental and Social Impact Assessment
SF	Solar Field
SGS	Steam Generation System
SO <sub>2</sub>	Sulphur Dioxide
SPC	Solar Power Complex
TES	Thermal Energy Storage

Abbreviation	Meaning
TSS	Thermal Storage System
TOR	Terms of Reference
TPH	Total Petroleum Hydrocarbons
UNESCO	United Nations Educational, Scientific and Cultural Organization
VOC	Volatile Organic Compounds
WB	World Bank
WI	Work Instructions
WHO	World Health Organisation
WSC	Water-Steam Cycle
WTO	World Trade Organization
WWTP	Wastewater Treatment Plant
Zn	Zinc
5 Capitals	5 Capitals Environment and Management Consultancy

---

**NON-TECHNICAL SUMMARY**  
**PLEASE REFER TO SEPARATE VOLUME**

## 1 INTRODUCTION

### 1.1 General Background

The Moroccan Agency for Solar Energy (MASEN) is planning to construct a 500MW solar power complex in Ouarzazate, to meet the national renewable energy policy objectives. The consortium, lead by ACWA Power has been awarded NOORo II parabolic Concentrated Solar Power (CSP) Plant ('the project'), which will produce 200MW using parabolic solar power concentration technology.

MASEN prepared a Framework Environmental and Social Impact Assessment (FESIA) for the 500MW Solar Power Complex. '5 Capitals Environmental and Management Consulting' (5 Capitals) has been commissioned by ACWA Power to undertake the Specific Environmental and Social Impact Assessment (SESIA) for the proposed NOORo II parabolic Concentrated Solar Power (CSP) Plant in Ouarzazate, in Morocco.

The project is situated on a greenfield of the Ait Ogrour Toundout rural community, and falls within the administration of the Ghassate Commune. The proposed project sits adjacent to the national road connecting Ouarzazate and Errachidia, and is approximately 10Km north east of the city of Ouarzazate and 6Km north of National Road N10. The specific plot for the project has a total area of 612ha, and the electricity generated will be supplied to the Ouarzazate 225/60 KV station located on the complex, from where the electricity is fed into the national grid.

It is understood that construction is expected to last about 25months from Notice to Proceed, followed by 1 year of optimization and demonstrating performance guarantees to reach Final Commercial Operation.

### 1.2 Assessment Objectives

The following SESIA document has several objectives in relation to its preparation, use and application for the NOORo II CSP project. Such objectives include and are not limited to the following:

- The assessment of baseline conditions prior to development;
- The assessment of potential impacts of the project during construction and operation;
- Ensuring that potential impacts are avoided or minimised through the recommendation of mitigation measures;
- Inclusion, information and consultation with the public, public bodies and local populations regarding the project;

- Exploration of alternatives that can be used for the project leading to greater social and environmental gains.

The analysis of the physical, natural and social environment has considered the immediate site as well as a well-defined buffer surrounding the project site.

It should be noted that the decommissioning phase of the project has only been discussed in general terms, since the NOORo II CSP is contracted under a 25 year BOOT scheme (Build-Own-Operate-Transfer). Therefore, the ownership of the SCP will be handed over to MASEN at the end of the 25 year period and consequently the responsibilities for the decommissioning of the plant will fall under the responsibility of MASEN.

### 1.3 Report Structure

In order to comply with the requirements for environmental assessment and international best practice, this report is presented in the following format:

**Volume 1:** Non-Technical Summary and Main Text

**Volume 2:** Technical Appendices

**Volume 3:** Environmental and Social Management Plan

Volume 1 comprises the Non-Technical Summary and main text of the report with the issues identified that the NOORo II CSP may impact upon (following the framework assessment) each following a similar general structure:

- Introduction and Project Background;
- Legal Framework, Standards and Guidelines;
- Methodology;
- Baseline Information;
- SESIA Assessment Method;
- Assessment of Effects/Impacts, Mitigation Measures, and Residual Effects During Construction Phase;
- Assessment of Effects/Impacts, Mitigation Measures, and Residual Effects During Operational Phase; and
- Assessment of Effects/Impacts, Mitigation Measures, and Residual Effects During De-Commissioning Phases, where relevant.

Volume 2 comprises all Technical Appendices (consultation meeting, baseline survey reports, monitoring reports and other Technical Studies).

Volume 3: provides the framework for the development of the Construction Environmental Social Management Plan (CESMP) by the main contractor and all sub-contractor; and the

Operational Environmental and Social Management Plan (OESMP) to be developed by the project proponent and implemented by the Operation and Management (O&M) team.

## **2 POLICY, LEGAL AND ADMINISTRATIVE FRAMEWORK**

### **2.1 Requirements For Environmental Assessment**

#### **2.1.1 National Requirements**

The law no. 12-03 for the year 2003 sets out the process for conducting an Environmental Impact Assessment (Etude d'Impact sur l'Environnement) within Morocco. Any project, which may have a significant impact on the environment, must have a comprehensive EIA carried out, before permission to operate (or license to begin construction) can be given.

The Environment Department is the government authority entrusted to enforce the environmental regulations for the EIA and is contained within the Ministry of Energy, Mines, Water and Environment (MEMEE). Decree No. 2-04-563 outlines the roles and responsibilities of the national and regional committees, which will be entrusted, with the review and approval of the SESIA.

The National Committee (CNEIE) will review projects, which are over 200 million Dirhams in investment, and the Regional Committee (CREIE) will review projects that are under 200million Dirhams in investment.

#### **2.1.2 International Requirements**

The project will be co-financed by the AfDB, World Bank, CTF, AFD, KfW, EIB, and the EC's Neighbourhood Investment Facility (NIF).

At the Second High Level Forum on Aid Effectiveness (2005) it was recognised that aid could - and should - be producing better impacts. The Paris Declaration was endorsed in order to base development efforts on first-hand experience of what works and does not work with aid. It is formulated around five central pillars: Ownership, Alignment, Harmonisation, Managing for Results and Mutual Accountability.

In 2008 at the Third High Level Forum on Aid Effectiveness an even greater number and wider diversity of stakeholders endorsed the Accra Agenda for Action (AAA). The AAA both reaffirms commitment to the Paris Declaration and calls for greater partnership between different parties working on aid and development.

#### **A. The World Bank Environmental Safeguard Policies**

The World Bank (WB) has 10-major Social and Environmental Safeguards that are applicable in development projects. The World Bank considers these policies to be the cornerstone of its

support to sustainable poverty reduction. The objective of these policies is to prevent and mitigate undue harm to people and their environment in the development process. These policies provide guidelines for bank and borrowers in the identification, preparation, and implementation of programmes and projects. The policies that have been triggered by this project, according to the Integrated Safeguards Data Sheet for the Concept Stage (disclosed on the 16-Apr-2014) are:

- **Environmental Assessment:** *"The WB states that project has potential adverse environmental risks in its area of influence due to water consumption (mirror washing) and risk of toxic fluid leaks. The FESIA (Framework Environmental and Social Impact Assessment) prepared under the Ouarzazate Phase I (now the "NOORo I") Project has been updated to cover the environmental and social safeguards issues for the NOORo II and NOORo III Projects, as both concern the same site and the same type of infrastructure (except for the solar tower) to be developed on the site. As this project is a scale-up activity to the solar thermal plant under construction, cumulative environmental impacts especially on the ecosystems and soil/groundwater have been assessed in the updated FESIA and ESIA's for each power plant".*
- **Involuntary Resettlement:** *"According to the WB safeguard datasheet, OP 4.12 was triggered for NOORo I and will continue to be triggered for NOORo II/III. The large part of the land acquisition needed for the project (mainly for the actual Solar Complex) was carried out during phase I. The 10,000 ha of land acquired for the site consisted entirely of communal land. Although the sale was based on a willing buyer willing seller agreement, the Bank required a Land Acquisition Plan (LAP) to be prepared and disclosed. During phase II, particular attention will be given to monitoring of land acquisition for Associated Facilities with a view to ensuring due process and minimizing impacts on local vulnerable populations".*

Although the land acquisition process was a voluntary process, the WB has determined that this operation triggered the Involuntary Resettlement Policy. Therefore, a Land Acquisition Plan (LAP) to describe the land acquisition process and monitor use of the proceeds to the benefit of the local population was prepared. The LAP includes, in particular, the following documents: a) copy of the land price committee determination of the price of the land, b) copy of the written agreement by the community of the Ait Oukroun Toundout on the sale and conditions of the transfer of the land, c) copy of the authorization of the Supervisory Board about the transaction and d) ONE/MASEN/Community tripartite agreement on land acquisition. The land acquisition was completed as per the process described in the LAP, in July 2011.



Furthermore, as Masen fully owns the land of the Project, all aspects relating to social safeguards in the context of the land acquisition and the implementation of the LAP are MASEN's responsibility. In effect, MASEN will be responsible for defining and evaluating the mitigation measures in connection with social impacts and resettlement of population, and presenting information, consultation and compensation procedures for the population in this context.

No additional land acquisition will be required for NOORo II. If land acquisition for Associated Facilities of the Solar Power Complex is necessary, this will be assessed in the SESIA for these facilities.

### **B. IFC Guidelines**

The World Bank Group / International Finance Corporation (IFC), Environmental, Health and Safety (EHS) General Guidelines of April 2007 superseded the World Bank Handbook issue of 1998. In addition, a number of sector specific guidelines have been revised or are undergoing peer review.

The updated EHS Guidelines serve as a technical reference source to support the implementation of the IFC Performance Standards, particularly in those aspects related to Performance Standard 3: Resource Efficiency & Pollution Prevention, as well as certain aspects of Performance Standard 4: Community Health, Safety and Security.

When Moroccan Environmental regulations differ from the levels and measures presented in the EHS Guidelines, the Project will be expected to achieve whichever is more stringent.

### **C. European Investment Bank**

The EIB Environmental and Social Handbook (Version 9.0 of 02/12/2013) states that the assessment of environmental and social impacts and risk, including their significance and materiality, as well as the development of adequate management plans and programmes are key tools for achieving sound environmental and social performance. In this respect, all EIB-financed operations shall comply with national legislation and international conventions and agreements ratified by the host Country. In addition, operations outside the EU must meet best international practice with regards to the assessment and management of environmental and social impacts and risks, promote good environmental and social governance and align with relevant EU principles and standards.

The handbook includes requirements on the assessment of pollution prevention and abatement, biodiversity and ecosystems, climate-related standards, cultural heritage, involuntary resettlement, rights and interests of vulnerable groups, labour standards, occupational and public health, safety and security and stakeholder engagement. The

handbook also includes requirements on the ESIA minimum contents and on the preparation of environmental and social management plan (ESMP) based on the conclusions of the ESIA.

The EIB's Environmental and Social Principle and Standards (2009) state that In the case of co-financing, the Bank is prepared to accept a common approach based on the relevant requirements of one of its financial partners, for reasons of consistency and harmonization, and to avoid duplication. For instance, in projects outside the EU, working in cooperation with other international public and private financial institutions, a common approach based on the Equator Principles or the safeguards of the World Bank may be followed.

#### **D. KfW Development Bank**

KfW Sustainability Guideline April 2014 require the preparation of an environmental and social assessment and climate change assessment to anticipate and appraise any foreseeable impact a project may have on the environment, the climate and/or on social factors, and to identify and prevent any negative impact, or limit it to a tolerable level and (provided that the negative impact is inevitable but still tolerable) introduce compensation measures. In addition, the assessments should identify, monitor and manage any residual risks. The objective of the climate change assessment is also to recognise climate change impacts that may impair the achievement of objectives in due time so that, if applicable, required adaptation measures can be taken into consideration in the project conception.

The sustainability guidelines state that when several lenders take part in a project, the ESIA's will apply internationally recognised environmental and social standards (e.g. World Bank Safeguard Policies, IFC Performance Standards, Environmental, Health and Safety Guidelines of the World Bank Group, ILO Core Labour Standards, EU Environmental Legislation), as KfW Development Bank aims to improve donor harmonisation in accordance with the Paris Declaration.

#### **E. Agence Francais de Development**

AFD Group created its environmental, social and governance policy in 2007 to improve risk management. AFD Group has listed exclusionary criteria that it uses to deny project-funding requests on ethical, regulatory, environmental or social grounds. All Group-financed foreign aid operations must comply with the target country's national laws. However, in cases where a country's laws are incomplete or changing, the Group applies standards, rules and good practices for project financing, as set by multilateral peer institutions, including:

- The World Bank safeguard policies for public sector financing; and
- The International Finance Corporation performance standards for private sector financing.

The Group also draws on their international conventions, declarations and guidelines that it (and its aid beneficiaries) have signed. The AFD also aims at creating common practices and procedures among peer institutions – AFD currently works with the World Bank, KfW and the European Investment Bank.

#### **F. The AfDB Environmental Safeguard Policies**

The AfDB's has an environmental safeguard system (December 2013) to manage environmental and social risks. The Integrated Safeguards System is a tool for identifying risks, reducing development costs and improving project sustainability. It promotes best practices and encourages transparency and accountability.

The following safeguards are particularly relevant:

- Operational Safeguard 1: Environmental and social assessment. This operational safeguard includes the requirements for the Environmental and Social Impact Assessment Process. It states that borrowers or clients are responsible for conducting the environmental and social assessment (Strategic Environmental and Social Assessment (SESA), or Environmental and Social Impact Assessment (ESIA)) and for developing, as an integral part of the project documentation, an appropriate plan for managing possible impacts. The safeguard document includes requirements for the different stages of the assessment process.
- Operational safeguard 2: Involuntary resettlement, land acquisition, population displacement and compensation. This Operational Safeguard aims to facilitate the operationalisation of the Bank's 2003 Involuntary Resettlement Policy in the context of the requirements of OS1 and thereby mainstream resettlement considerations.
- Operational Safeguard 3: Biodiversity and ecosystem services. Requires, inter alia, that as part of the environmental and social assessment, the borrower or client identifies and assesses the potential opportunities for, risks to, and impacts on biological diversity and ecosystem services, including direct, indirect, cumulative and pre-mitigation impacts. It also requires the borrower or client to apply the mitigation hierarchy.
- Operational Safeguard 4: Pollution prevention and control, hazardous materials and resource efficiency. This safeguard covers the range of key impacts of pollution, waste, and hazardous materials for which there are agreed international conventions, as well as comprehensive industry-specific and regional standards, including greenhouse gas accounting, that other multilateral development banks follow.
- Operational Safeguard 5: Labour conditions, health and safety. Includes requirements regarding working conditions, such as the management of worker

relationships, workers organisations, non-discrimination, retrenchment, and the grievance mechanism, and it includes safeguards for the pretention of the workforce, addressing, for example, child labour.

### **G. The Equator Principles**

On 4th June 2003, ten banks from seven countries signed up to the Equator Principles (EPs), a voluntary set of guidelines for assessing and managing environmental and social risks in project financing. Currently, over seventy-five major financial institutions from around the world have adopted the EPs. These financial institutions operate in more than 100 countries worldwide. As a result, the Equator Principles have become the project finance industry standard for addressing environmental and social issues in project financing globally. The Equator Principles were updated in 2006 (EP II) to include projects with a capital cost of US\$10 million or more across all industry sectors and these are the prevailing applicable conditions for this project.

The Equator Principles Financial Institutions (EPFIs) reviewed the Equator Principles in 2011 and approved the latest version, EP III on April 26th 2013. These became effective from June 4th 2013 and should be fully implemented by December 31st 2013.

It is possible that an EPFI will take part in the financing of some of the activities of ACWA Power or the consortium.

The revised Equator Principles detail projects that are classified as Category A or B projects are required to complete and disclose Environmental and Social Impact Assessment (ESIA). This process determines the environmental and social impacts and risks (including labour, health and safety) of a proposed project in its area of influence. The Assessment should also propose mitigation and management measures relevant and appropriate to the nature and scale of the proposed project.

The anticipated environmental and social impacts identified and mitigated in this project are not unprecedented, can be readily mitigated and may be reversed in the future. However, since the WB Regional Safeguard Adviser has categorised the NOORo II Power Plant Project as Category A. For this reason, the environmental and social assessment has been undertaken to meet Category A requirements.

#### **2.1.3 SESIA Procedure**

The international ESIA requirements largely follow the same principles noted within the Moroccan environmental regulations with regards to the assessment methodology, although the requirements of the WB/IFC, the Equator Principles and other lenders, in comparison to the national standards, gives comparatively greater emphasis to the social assessment of projects, stakeholder engagement and disclosure.

The term FESIA (Framework Environmental and Social Impact Assessment) has been used in the Kingdom of Morocco to refer to the reports that assess the high level impacts of programmes, such as the undergoing programme to build three CSP plants in Ouarzazate (what internationally is called Strategic Environmental Assessment). For the three phases of the SPC the FESIA compared the impacts of different solar technologies and established the baseline for the site. The term "Specific Environmental and Social Impact Assessment" (SESIA) has been used to describe NOORo II CSP project specific assessments. Given the relative similarity content between SEAs and SESIAs and in the interest of consistency, 'SESIA' is the term that will be referred to throughout the rest of this report.

## 2.2 Standards and Guidelines

The SESIA study will adopt and comply with the following environmental standards to ensure that the proposals meet the relevant national and international requirements:

- National environmental legislation, regulations and standards; and
- World Bank / IFC standards: The WB/IFC standards are used for harmonization purposes, following the principles of the Paris Declaration on donor harmonization.

In addition to the above, and as mentioned in Section 2.1.2 the environmental and social policies of the following lending institutions have been considered in the proposed project's assessment of impacts AfDB, World Bank, CTF, AFD, KfW, EIB, and the EC's Neighbourhood Investment Facility (NIF).

### 2.2.1 National

The main Moroccan legislation with regards to the environment consist of the following, which the proposed plant will be required to comply with:

- Law No 12-03 concerning the environmental impact study process.

Promulgated by Dahir No. 1-03-06 of 10 Rabii I 1424 (12 May 2003), lists the projects subject, the procedure of implementation and methodology of impact studies.

This Act establishes the creation of a national committee and regional committees entrusted with the review of the environmental impact studies.

- Law No 11-03 concerning the protection and improvement of the environment.

This law sets the general framework for the protection of the environment in Morocco, by identifying:

- Principles of environmental protection related to human settlements and the protection of nature and natural resources;
- Principle for establishing discharge standards and the definition of nuisances;

- Management tools and protection of the environment that are described within the impact studies, plans and standards.
- Standards of environmental quality and financial and tax incentives. The law also establishes a national fund for the protection and enhancement of the environment;
- Procedural rules defining the responsibilities and obligations in the event of damage.
- Law No 13-03 concerning air pollution and decree No 2-09-286 of 23 Rajeb 1431.

Chapter II of the Act, Article 2 states that the Act applies to any person or entity, public or private, who owns or possesses or uses or operates buildings or mining, industrial, commercial, agricultural or crafts. It also applies to motor vehicles or equipment or combustion or waste incineration or heating or cooling.

Chapter III of the Act, Article 4 states that "it is forbidden to release, issue or refuse to allow the release, emission or discharge of pollutants in the air such as toxic gas or corrosive fumes, vapours, heat, dust, odours beyond the quality or concentration allowed by the standards laid down by regulation. "

This article also states that "in the absence of standards laid down by regulation, operators of installations referred to in Article 2 are required to apply the most advanced technologies available to prevent or reduce emissions."

Through Decree No. 2-09-286 of 20 Di Hijja 1430 (8 December 2009), this law sets standards for air quality and air monitoring.

- Law 10-95 concerning water management and decree No. 2-04-553 and 2-97-787 regarding wastewater management and water quality standards, respectively.

Decree 553 paves the way for the effective implementation of reporting procedures for existing discharges and subsequent payment of fees. The implementation of the Decree induces the need to:

- Request authorization to discharge from the concerned water authority;
- Meet the discharge limits set by domestic Order No. 1607-06 (25 July 2006).

Decree 787 aims to define quality classes to normalize and standardize the assessment of water quality. It also defines orders via quality standards which water must meet depending on the treated water use, including:

- Potable water;
- Irrigation;
- Wastewater for irrigation and aquaculture.

- Law No 28-00 concerning Waste Disposal and Management.

This Act aims to prevent and protect human health, fauna, flora, water, air, soil, ecosystems, sites and landscapes and the environment in general against the effects of harmful waste, by ensuring the following:

- The reduction of harmful waste production;
- The organization of the collection, transport, storage, waste treatment and disposal in an environmentally sound manner;
- The recovery of waste by reuse, recycling or any other operation reusable means for energy recovery;
- Planning national, regional and local management and disposal waste;
- Informing the public about the harmful effects of waste on public health and environment as well as measures to prevent or compensate for their adverse effects;
- The establishment of a system of control and punishment for offenses.

## **2.2.2 International and Regional Conventions ratified by Morocco**

The international and regional conventions and protocols that are relevant to protection of the environment will be acknowledged in relation to the environmental impact assessment of the proposed Integrated NOORo II CSP, are provided below:

### **Bonn Convention on Migratory Species of Wild Animals (1983).**

This global convention created in 1979 by the United Nations Environment Program (UNEP) is an agreement for the conservation of migratory species of wild animals. Two appendices list migratory species that require conservation measures.

Appendix 1 includes species threatened with extinction, and Appendix 2 lists migratory species whose conservation status requires an international agreement of cooperation.

Under the Bonn Convention Morocco has signed several agreements including the Agreement on the Conservation of Migratory Waterbirds in Africa - (AEWA). To this end the Contracting Parties "... investigate problems that arise due to human activities and endeavor to implement remedial measures including restoration and habitat rehabilitation and compensatory measures for loss of habitat. "

### **Washington Convention on International Trade in Endangered Flora and Wildlife (CITES 1975).**

Morocco has signed the Convention in 1975 and entered into force in 1976. Its aim is to ensure that international trade in specimens of wild animals and plants does not threaten the survival of the species in the wild, and it accords varying degrees of protection to more than

34,000 species of animals and plants. This convention is regularly cited as a reference to the threat level of the species.

**Protecting the ozone layer: the Montreal Protocol (1992);**

As a party to the Montreal Protocol, has the obligation to protect the ozone layer by taking precautionary measures to control equitably total global emissions of substances that deplete it, with the ultimate objective of their elimination on the basis of developments in scientific knowledge, taking into account technical and economic considerations and bearing in mind the developmental needs of developing countries.

**RAMSAR convention on the protection of Wetlands of International Importance (1971, updated 1980).**

Morocco has committed to maintain the ecological character of its Wetlands of International Importance and to plan for the sustainable use, of all of the wetlands in its territories.

The Convention uses a broad definition of the types of wetlands covered in its mission, including lakes and rivers, oases, estuaries, and human-made sites such as fish ponds, and reservoirs, to name a few.

**Climate Change Framework: United Nations Convention on Climate Change (1995) and protocol of Kyoto (2002)**

Morocco has committed to develop national inventories of anthropogenic emissions and removals of greenhouse gases, consider climate change in policies and actions and adopt methods such as impact assessments, and formulate mitigation measures.

**Biodiversity Convention of Rio Janeiro on Biological Diversity (1995)**

Committed to the conservation and maintenance of biological diversity alongside economic development.

**Vienna Convention and the London amendment (1995)**

Morocco was committed to adopt appropriate legislative or administrative measures and co-operate in harmonizing appropriate policies to control, limit, reduce or prevent human activities under their jurisdiction or control should it be found that these activities have or are likely to have adverse effects resulting to the depletion of the ozone layer.

**African Convention on the Conservation of Nature and Natural Resources whose acts were reaffirmed at Earth Summit in Johannesburg in South Africa in 2002**



This agreement was signed in Algiers on 15 September 1968, replacing the London Convention 1933. Its objectives include the conservation of species, the creation of protected areas and conservation, utilization and development of soil, water, flora and fauna. The Convention establishes three categories of protected areas in parks, reserves and special reserves and introduces the concept of optimal handling for sustainable wildlife resources.

### **The International Convention for the Protection of Birds**

Replaces and enhances the Convention for the Protection of Birds Useful to Agriculture, held in Paris in 1902. The updated convention is essentially based on ecological considerations, even if Article 5 introduces an ethical argument and it prohibits the infliction of unnecessary suffering to birds. This Convention shall be applied without exception to all wild birds and designed specifically to protection of all species during their breeding and migration.

### **The World Heritage Convention**

The World Heritage Convention was adopted by the United Nations Educational, Scientific and Cultural Organisation (UNESCO) General Conference, in Paris 1972. It aims to promote cooperation among nations to protect heritage around the world that is of such outstanding universal value that its conservation is important for current and future generations. It is intended that, unlike the seven wonders of the ancient world, properties on the World Heritage List will be conserved for all time.

## **2.2.3 Environmental Standards**

### **Soil**

As specific Moroccan standards and guidelines for soil protection are currently unavailable, internationally recognized assessment values for soil contamination set by the Dutch Ministry of Housing, Spatial Planning and Environment have been applied for the purpose of the SESIA for the Project. The baseline results have been compared against standard values and guidelines.

In the Netherlands, environmental quality values have been established based on the philosophy of protecting ecosystems, environmental functions and ensuring the multi-functionality of soil and groundwater quality. These are discussed below:

- Target Value: average background concentration or detection limit; exceeding this value indicates a possible diminishing of the functional abilities of the soil for humans, plants or animals.
- Intervention Value: concentration level above which there is a serious or threatening diminishing of the functional abilities of the soil for humans, plants or animals.

Table 2-2 provides a list of the Dutch Soil and Groundwater standards that the proposed project will be required to comply with.

With reference to these standard values, the target values for soil represent the level at which environmental sustainable soil quality is present.

Constituent levels greater than the target value indicate that the soil has lost some of its multi-functional properties and can be considered as contaminated soil. If the contamination level is exceeding the intervention value, further investigation will be carried out. The soil intervention values indicate when the functional properties of the soil are seriously impaired or threatened.

It will be noted that the target values are not specific clean up criteria. They represent targeted objectives. Also, in the latest (2009) version of the Dutch Standard, Target values for soils have been removed for all compounds except Metals.

The IFC EHS regulations do not specify pollutant standards for soils. In light of this, sector-specific guidance documents on pollution prevention and good practices produced by the IFC (e.g. IFC 'Environmental Health and Safety Guidelines (EHS) Guidelines: Contaminated Land' (2007)) will be referred to in the assessment. Such guidance includes the following:

The General EHS guidelines detail that the '...Transfer of pollutants to another phase, such as air, soil, or the sub-surface, will be minimized through process and engineering controls.'

Section 1.8 of the IFC's General Guidelines details the specific requirements with regards to contaminated land. It notes that: "*Contamination of land will be avoided by preventing or controlling the release of hazardous materials, hazardous wastes, or oil to the environment. When contamination of land is suspected or confirmed during any project phase, the cause of the uncontrolled release will be identified and corrected to avoid further releases and associated adverse impacts.*"

**Table 2-1 Dutch Soil Standards**

Contaminant	Dutch Soil mg/Kg dry weight	
	Target	Intervention
<b>Beryllium</b>	1.1	30
<b>Cadmium</b>	0.8	12
<b>Chromium (total)</b>	100	220
<b>Cobalt</b>	20	180
<b>Copper</b>	36	96
<b>Lead</b>	85	530
<b>Nickel</b>	35	100
<b>Mercury</b>	0.3	10
<b>Molybdenum</b>	3	190
<b>Selenium</b>	0.7	100

<b>Thallium</b>	1	15
<b>Vanadium</b>	42	250
<b>Zinc</b>	140	350
<b>Benzene</b>	0.05	2
<b>Total PAH</b>	1	40

## Water and Wastewater

### *National Requirements*

The Water Act, Law 10-95 on water and its implementing regulations, was promulgated on 16 August 1995. It aims to ensure the rational use of water and access to this resource throughout the Kingdom. The main decrees implementing this law published to date are:

- Decree No. 2-04-553 of 13 Hijja 1425 (24 January 2005) relating to spills and direct and indirect discharges into surface or groundwater (O.B. No. 5292 of 17 February 2005)
- Dahir 2-97-787 on the establishment of water quality standards

This decree regulates water discharges, including runoff and direct or indirect discharges to surface water or groundwater.

As a result of the implementation of this decree an authorization has to be requested for water discharges from the relevant authorities.

In addition, domestic discharge standards set by Order No. 1607-06 (July 25, 2006), are shown in table 2-5.

- Decree No. 2-05-1533 covers wastewater discharges from rural settlements.
- Decree No. 2-97-875 of 6 Shawwal 1418 (4 February 1998) on the use of wastewater (O.B. 5 February 1998). This Decree regulates the reutilization of wastewater. An authorization is required for wastewater reuse except for onsite reutilization.
- Decree No. 2-97-657 of 6 Shawwal 1418 (4 February 1998) on the delimitation of protected areas (B.O. February 5, 1998), which regulates zoning around public waters.
- Decree No. 2-97-787 of 6 Shawwal (4 February 1998) on water quality standards and water pollution inventories (O.B. No. 4558 of 5 February 1998). This Decree defines, inter alia, the necessary parameters for the assessment of water quality and the quality standards that water must meet depending on its use.

To date, the legislations enacted based on this decree are:

- Decree n ° 1277-1201 enacted on the 17th of October 2002 on quality standards for water used for the production of drinking water. These standards are specified in Chapter 11,
- Order 1276-01 enacted on the 17th of October 2002 on quality standards for irrigation water. These standards are specified in Chapter 11;
- Decree n ° 1275-1201 enacted on the 17th of October 2002 on quality of surface waters;
- Decree No. 2028-03 enacted on the 10th of November 2003 on quality standards for fishing waters.

**Table 2-2 Water Standards for irrigation**

PARAMETERS	UNITS	VALUE	SPECIFICATIONS
<b>Biological Parameter</b>			
Faecal Coliform	ml	1000/100	100ml for agricultural products eaten raw
Salmonella		Absence	in 5 litres
Vibrio cholera		Absence	in 450ml
<b>Parasitological Parameter</b>			
Pathogenic parasites		Absence	
Parasite cysts		Absence	
Larvae of Ankylostomides		Absence	
Fluococercaires of Schistosoma haematobium		Absence	
<b>Toxic Parameters</b>			
Mercury	mg/l	0.001	
Cadmium	mg/l	0.01	
Arsenic	mg/l	0.1	
Total Chromium	mg/l	1	
Lead	mg/l	5	
Copper	mg/l	2	
Zinc	mg/l	2	
Selenium	mg/l	0.02	
Fluorine	mg/l	1	
Cyanides	mg/l	1	
Phenols	mg/l	3	
Aluminium	mg/l	5	
Beryllium	mg/l	0.1	
Cobalt	mg/l	0.5	
Iron	mg/l	5	
Lithium	mg/l	2.5	
Manganese	mg/l	0.2	
Molybdenum	mg/l	0.01	
Nickel	mg/l	2	
Vanadium	mg/l	0.1	
<b>Physical and Chemical properties</b>			
<b>Salinity</b>			
Total salinity	mg/l	7680	
Electrical conductivity	mS/cm	12	at 25°C

<b>Infiltration</b>			
- Sodium Absorption Ratio 0-3	EC	< 0.2	
- Sodium Absorption Ratio 3-6		< 0.3	
- Sodium Absorption Ratio 6-12		< 0.5	
- Sodium Absorption Ratio 12-20		< 1.3	
- Sodium Absorption Ratio 20-40		< 3	
<b>Toxic Ions (affecting sensitive agricultural product receptors)</b>			
<b>Sodium</b>			
- Surface Irrigation	mg/l	69	
- Overhead irrigation	mg/l	9	
<b>Chloride</b>			
- Surface Irrigation	mg/l	350	
- Overhead irrigation	mg/l	15	
Boron	mg/l	3	
<b>Effect drivers (affecting sensitive agricultural product receptors)</b>			
Temperature	°C	35	Temperature
pH		6.5 to 8.4	pH
Suspended solids			Suspended solids
- Gravitational Irrigation	mg/l	200	- Gravitational Irrigation
- Localised overhead irrigation	mg/l	100	- Localised overhead irrigation
Nitrate (N-NO <sub>3</sub> -)	mg/l	30	Nitrate (N-NO <sub>3</sub> -)
Bicarbonate (HCO <sub>3</sub> ) [overhead irrigation]	mg/l	518	Bicarbonate (HCO <sub>3</sub> ) [overhead irrigation]
Sulphates (SO <sub>4</sub> <sup>2-</sup> )	mg/l	250	Sulphates (SO <sub>4</sub> <sup>2-</sup> )

**Table 2-3 Drinking Water Standards**

PARAMETER	UNITS	A1-G	A1-I	A2-G	A2-I	A3-G	A3-I
<b>Toxic Substances</b>							
Arsenic	μ g/l	-	50	-	50	-	100
Cadmium	μ g/l	1	5	1	5	-	5
Chromium (total)	μ g/l	-	50	-	50	-	50
Cyanides	μ g/l	-	50	-	50	-	50
Lead	μ g/l	-	50	-	50	-	50
Mercury	μ g/l	-	1	-	1	-	1
Nickel	μ g/l	-	50	-	50	-	50
Selenium	μ g/l	-	10	-	10	-	10
Pesticides, per substance	μ g/l	-	0.1	-	0.1	-	0.1
Pesticides, total	μ g/l	-	0.5	-	0.5	-	0.5
HPA	μ g/l	-	0.2	-	0.2	-	0.2
<b>Undesirable Substances</b>							
Boron	mg/l	-	1	-	1	-	1
Ammonia	mg/l	0.05	0.5	1	1.5	2	4
TKN	mg/l	1	-	2	-	3	-
Nitrates	mg/l	-	5	-	50	-	50
Phosphorous	mg/l	0.4	-	0.7	-	0.7	-

Barium	mg/l	-	1	-	1	-	1
Copper	mg/l	-	1	-	2	-	2
Zinc	mg/l	-	50	-	5	-	5
Manganese	mg/l	-	0.1	0.1	0.1	1	-
Dissolved iron	mg/l	-	0.3	1	2	1	3
Fluorides	mg/l	0.7	1.5	0.7	1.5	0.7	1.5
Dissolved hydrocarbons	mg/l	-	0.05	-	0.2	0.5	1
Phenols	mg/l	-	0.01	-	0.05	-	0.1
Anionic detergents	mg/l	-	0.5	-	0.5	-	0.5
<b>Physical-chemical Parameters</b>							
Temperature	°C	20	30	20	30	20	30
pH		6.5-8.5	-	6.5-9.2	-	6.5-9.2	-
Conductivity at 20° C	μ S/cm	1300	2700	1300	2700	1300	2700
Chlorides	mg/l	300	750	300	750	300	750
Sulfates	mg/l	200	-	200	-	200	-
Suspended materials	mg/l	50	-	1000	-	2000	-
Dissolved Oxygen	mg/l	7 (90%)	-	5 (70%)	-	3 (50%)	-
BOD5	mg/l	3	-	7	-	10	-
COD	mg/l	-	-	25	-	40	-
Oxydability	mg/l	2	-	5	-	10	-
<p>Category A1: Water requiring a simple physical treatment and disinfection, including filtration, to be drunk.</p> <p>Category A2: Water requiring normal physical and chemical processing and disinfection, including pre-chlorination, coagulation, flocculation, sedimentation, filtration and disinfection (final chlorination), to be drunk.</p> <p>Category A3: Waters requiring physical treatment, chemical pushed refining and including disinfection by chlorination, coagulation, flocculation, sedimentation, filtration, adsorption and disinfection (ozone, final chlorination), to be drunk.</p> <p>Within each category, there are two columns:            Column G (guideline values): correspond to the recommended values that surface water to be used for the production of drinking water will satisfy to be classified into one of three categories.            Column I (mandatory values): values that are shown are the requirements that any surface water used for the production drinking water must meet to be classified in one of three categories.</p>							

**Table 2-4 Domestic Discharge Standards**

PARAMETERS	UNITS	VALUE
BOD5	O <sub>2</sub> /l	120
COD	O <sub>2</sub> /l	250
Suspended Materials	mg/l	150

### International Requirements

Two sections of the IFC general HSE guidelines, namely section 1.3 'Wastewater and Ambient Water Quality' and section 1.4 'Water Conservation' have been considered for this project.

**Table 2-5 Indicative Values for treated Sanitary Sewage Discharge**

Pollutants	Units	Guideline Value
pH	pH	6 – 9
BOD	mg/l	30
COD	mg/l	125
Total nitrogen	mg/l	10
Total phosphorus	mg/l	2
Oil and grease	mg/l	10
Total suspended solids	mg/l	50
Total coliform bacteria	MPNb / 100 ml	400a
Notes: a Not applicable to centralized, municipal, wastewater treatment systems which are included in EHS Guidelines for Water and Sanitation. b MPN = Most Probable Number		

### Air Quality

#### Moroccan Environmental Standards

Moroccan Law No. 13-03 establishes the regulations for prevention of air pollution. The law identifies and addresses the sources and types of air pollution, and stipulates that in the absence of any defined national regulations, the polluter is required to integrate and implement the latest technology available to reduce or prevent pollution to the air.

- Decrees No. 2-09-286 establishes the national ambient air quality standards and monitoring mechanisms. These are presented in Table 2-7.
- Decree No. 2-09-631 establishes point source and non point source emission levels, and the mechanism to control these emissions. These are presented in Table 2-8.

#### World Bank / IFC

The following IFC EHS guidelines have been considered for the air quality assessment:

- IFC Environmental, Health and Safety General Guidelines (2007) and specifically sections relating to Ambient Air quality.
- IFC/WB EHS Guidelines for Thermal Power Plants (2008) and specifically sections relating to Air Emissions.

The IFC Thermal Power Plant Boiler Emissions Guidelines has been chosen, given that the projects two boilers will be used intermittently, (during low solar radiation) to maintain the optimal operating conditions of the HTF and Thermal Storage System, and therefore indirectly

contribute to the overall operation of the Steam Generation System and production of power by thermal processes.

The assessment of air quality primarily ensures compliance with Moroccan regulations and standards. Where national regulations differ from the guidelines and standards presented in the IFC/WB guidelines, the project will be required to achieve whichever is the more stringent. As per the IFC/WB EHS Guidelines, the WHO ambient air quality standards are applicable in the absence of any national ambient air quality standards.

The following tables present the air emission standards that must be achieved, including those described above, extracted from: Decree 286 and 631 and World Bank/IFC EHS Guidelines.

**Table 2-6 Ambient Air Quality Standards ( $\mu\text{g}/\text{m}^3$  unless otherwise specified)**

Parameter	IFC EHS General GLs/WHO GLs		Moroccan		
	24 hour	Annual	1 hour	24 hour	Annual
<b>PM10</b>	150 (Interim target 1)	70 (Interim target 1)	-	90.4 50%centile	-
	100 (Interim target 2)	50 (Interim target 2)			
	75 (Interim target 3)	30 (Interim target 3)			
	50 (guideline)	20 (guideline)			
<b>PM2.5</b>	75 (Interim target 1)	35 (Interim target 1)	-	-	-
	50 (Interim target 2)	25 (Interim target 2)			
	37.5 (Interim target 3)	15 (Interim target 3)			
	25 (guideline)	10 (guideline)			
<b>Nitrogen Dioxide</b>	200 (1 hour)	40	98 200%centile	-	50 health 30 vegetation
<b>Sulphur Dioxide</b>	125 (Interim target 1)	500 (10 minute guideline)	-	99.2 125%centile	20 (ecosystem)
	50 (Interim target 2)				
	20 (guideline)				
	150 (Interim target 1)				
<b>Ozone</b>	100 (8 hour daily maximum guideline)	-	110 for 8hr	65 vegetation	-
<b>Carbon Monoxide</b>	-	-	10mg/m <sup>3</sup> for 8hr	-	-
<b>Cadmium</b>	-	-	-	-	5ng/m <sup>3</sup>



					Health
<b>Benzene (C6H6)</b>	-	-	-	-	10 Health
<b>Pb</b>	-	-	-	-	1 Health

**Table 2-7 Moroccan and IFC Maximum Permissible Emission Rates for Boilers**

Pollutant	Units	Moroccan	IFC Boilers thermal power plants (One Hour Average)		IFC Small Combustion Facilities Emissions Guidelines
			NDA <sup>1</sup>	DA <sup>2</sup>	
Particulate Matter Total	mg/Nm <sup>3</sup>	5mg/m <sup>3</sup> for an emission rate of 25g/hr	50	30	50 - 150
Nox (as NO <sub>2</sub> )	mg/Nm <sup>3</sup>	500mg/m <sup>3</sup> at emission rate of 5000g/h	400	200	460
Sox (as SO <sub>2</sub> )	mg/Nm <sup>3</sup>	500mg/m <sup>3</sup> at emission rate of 5000g/h	900-1,500	400	2000
HCl	mg/Nm <sup>3</sup>	1mg/m <sup>3</sup> at emission rate of 5g/h			

1 NDA is non degraded airshed (i.e. NOORo II Project Site)

2 DA is degraded airshed (this does not apply to NOORo II)

### Noise and Vibration

Currently no noise regulations or standards are available within the Moroccan environmental regulatory system. Therefore, the proposed plant will be required to comply with the noise limits as specified by the IFC EHS General Guidelines (2007).

These guidelines represent maximum noise values that must be achieved at surrounding/nearby receptors. It is stated within the IFC EHS Noise Level Guidelines that noise impacts will not exceed the levels which are presented in Table 2-9, or result in a maximum increase in background levels of 3dB at the nearest off-site point of reception.

**Table 2-8 IFC EHS General Noise Guidelines (at off-site receptor)**

Receptor	One Hour LAeq (dBA)	
	Daytime 07:00 – 22:00	Night time 22:00 – 07:00
Residential, Institutional, Educational	55	45
Industrial, Commercial	70	70

Furthermore, the following requirements have also been specified in the IFC EHS Occupational Health and Safety Guidelines (April 2007) regarding noise exposure limits:

- No employee will be exposed to a noise level greater than 85 dB (A) for duration of more than 8 hours per day without hearing protection. In addition, no unprotected ear will be exposed to a peak sound pressure level (instantaneous) of more than 140 dB(C);
- The use of hearing protection will be enforced actively when the equivalent sound level over 8 hours reaches 85 dB (A), the peak sound level reaches 140 dB(C), or the average maximum sound level reaches 110 dB (A). Hearing protective devices provided will be capable of reducing sound level at the ear to at least 85 dB (A);
- For every 3 dB (A) increase in sound levels, the allowed exposure period or duration will be reduced by 50%;
- Where feasible, use of acoustic insulating materials isolations of the noise source and other engineering controls will be investigated and implemented prior to the issuance of hearing protection devices as the final control mechanism; and
- Medical hearing checks on workers exposed to high noise levels will be performed periodically.

To help provide an understanding to the magnitude of noise, the following table describes noise levels subjectively in comparison to example sources/situations.

**Table 2-9 Relative Assessment of Noise**

Noise Level (dbA)	Examples	Subjective Evaluation
150	Jet take-off (at 25 metres)	Ear drum rupture
140	Near Jet Engine	Deafening
130	Threshold of pain	
120	Threshold of feeling - loud rock band, jet aircraft overhead. 32 times as loud as 70dB.	
110	Accelerating motor cycle nearby	
100	Loud vehicle horn	
90	Noisy urban street, motor mower nearby, noisy factory	Very Loud
80	Telephone ringing in same room, diesel truck at 65Km/h at 15m	Twice as loud as 70db
70	Baby crying in same room, vacuum cleaner being used, passenger car at 105Km/h at 7m	Loud. Upper 70 becomes annoying to some people
60	Freeway vehicle traffic nearby	
50	Average office, washing machine, large electrical transformers at 30m	Moderate
40	Soft radio music indoors, wind in trees	Low
30	Average residence	Faint
20	Close to average whisper	
10	Rustle of leaves in wind, human breathing	Very Faint
0	Threshold of audibility	

Source: U.S Department of Transportation. Federal Highway Administration, and Outdoor Noise and the Metropolitan Environment, M.C Branch et al., Department of City Planning, City of Los Angeles, 1970

### Vibration

It will be noted that none of the above standards set out specific standards in relation to vibration impacts at either the construction or operation phase. The IFC's General EHS Guidelines (2007) do however reference potential impacts from vibrations due to the use of hand held power tools and other equipment, as below:

*"Exposure to hand-arm vibration from equipment such as hand and power tools, or whole-body vibrations from surfaces on which the worker stands or sits, will be controlled through choice of equipment, installation of vibration dampening pads or devices, and limiting the duration of exposure. Limits for vibration and action values, (i.e. the level of exposure at which remediation will be initiated) are provided by the ACGIH66. Exposure levels will be checked on the basis of daily exposure time and data provided by equipment manufacturers."*

### **Solid and hazardous Waste Materials**

#### *National Requirements*

Law No. 28-00 establishes the framework for waste management and has set out guidelines and a methodology concerning the classification, transportation and disposal of waste.

Consequently, several decrees have been promulgated, which outline the procedures and standards that will be implemented to ensure compliant transport and disposal of wastes based on their classification. With respect to this project the following Decrees have been applied for the purpose of the SESIA:

- Decree No. 2-07-253 Identifies and lists hazardous wastes by Industrial process.
- Decree No 2-09-538 Identifies hazardous wastes management procedures.
- Decree No. 2-09-683 Identifies non-hazardous wastes management procedures.

#### *IFC/World Bank Requirements*

Section 1.5: Hazardous Materials Management and Section 1.6: Waste Management of the IFC General EHS Guidelines (2007) are applicable to all projects that generate, store or handle any quantity of waste. The waste management guidelines state that facilities that generate and store wastes will practice the following:

- Establish waste management priorities at the outset of activities based on an understanding of potential waste streams;
- Identify EHS risks and impacts and consider waste generation and its consequences;

- Establish a waste management hierarchy that considers prevention, reduction, reuse, recovery, recycling, removal and finally disposal of wastes;
- Avoid or minimise the generation waste materials, as far as practicable;
- Identify where waste generation cannot be avoided but can be minimized or where opportunities exist for, recovering and reusing waste; and
- Where waste cannot be recovered or reused, identify means of treating, destroying, and disposing of it in an environmentally sound manner.

In addition, Morocco is a non-OECD country. Therefore, the IFC Performance Standard 3: Resource Efficiency and Pollution Prevention has been considered during the assessment of waste in relation to the Project. Section 9 of this document specifically details that waste will be minimised, reused or recycled where possible, and treated and disposed in an environmentally sound manner.

The Basel Convention on the Control of Transboundary Movements of Hazardous Wastes and their Disposal obliges its Parties to ensure that hazardous and other wastes are managed and disposed in an environmentally sound manner. Parties are expected to minimise the quantities that are moved across border, to treat and dispose of waste as close as possible to their place of generation and to prevent or minimise the generation of wastes at source. Strong controls have to be applied from the moment of generation of a hazardous waste to its storage, transport, treatment, reuse, recycling, recovery and final disposal.

### **Stormwater Management**

IFC's Guidance Note 4 Community Health, Safety and Security, has been considered for this issue. The IFC's Guidance Note 4 requires that the exacerbation of impacts caused by natural hazards, such as landslides or floods that could arise from land use changes should be avoided or minimized.

Moroccan Law 10-95 on water and its implementing regulations establish the measures to protect artificial water bodies, the water quality, use of these water systems and protection of the watercourses.

- Decree No. 2-97-224: Setting the Conditions Governing the Artificial Accumulation of Water (1997)
- Decree No. 2-97-489, February 4 1998. Identifies publicly accessible water bodies, the procedures to manage these waterways, and their safe extraction.
- Decree No. 2-97-657, February 4 1998. Delineates protected areas, their buffer zones, and identified prohibited activities.

- Decree No. 2-04-553. January 24 2005. Identifies measure to prevent spills, leaks, and discharges and protect surface and ground waters from direct or indirect contamination events.

### **Ecology and Biodiversity**

Law No 11-03 concerning the protection and improvement of the environment provides a framework of legislation under which the Kingdom can meet its obligations as a signatory to the Convention on Biological Diversity (CBD).

In addition, the assessment of potential impacts upon the terrestrial ecology resources represented by the Project site has been undertaken with due consideration to IFC Performance Standard 6 - Biodiversity Conservation and Sustainable Natural Resource Management.

### **Socio-Economic**

Moroccan Labour Law no 65-99 concerning the Labour Code, is applicable to this project. Other legislation relating to the social and health sector includes:

- 17-08 (dahir 1-08-153 du 18 février 2009) regarding the Communal Charter
- Dahir 1-60-063 (25 June 1960) for the development of rural communities Order 23 November 1950. Ensures that medicinal products and medical equipment should be provided on-site, where 100 workers are permanently stationed or where projects are located more than 10 km from a supply centre.
- Decree 2-70-510 (8 October 1970) identifies preventive measures that should be implemented on construction sites.

The Kingdom of Morocco has also signed 54 International Labour Organisation (ILO) conventions, including the following:

- Unemployment Convention, 1919 (No. 2)
- Night Work (Women) Convention, 1919 (No. 4)
- Workmen's Compensation (Agriculture) Convention, 1921 (No. 12)
- Holidays with Pay Convention, 1936 (No. 52)
- Labour Inspection Convention, 1947 (No. 81)
- Right to Organise and Collective Bargaining Convention, 1949 (No. 98)
- Equal Remuneration Convention, 1951 (No. 100)
- Abolition of Forced Labour Convention, 1957 (No. 105)
- Discrimination (Employment and Occupation) Convention, 1958 (No. 111)
- Employment Policy Convention, 1964 (No. 122)
- Workers' Representatives Convention, 1971 (No. 135)

- Minimum Age Convention, 1973 (No. 138)
- Minimum age specified: 15 years
- Termination of Employment Convention, 1982 (No. 158)
- Asbestos Convention, 1986 (No. 162)
- Maternity Protection Convention, 2000 (No. 183)

Law no. 57-09 for the creation of the Moroccan Agency for Solar Energy provides the legal framework for the NOORo II Solar Power Complex and outlines how it aligns with the national economic and social development strategy.

Even though national policies and strategies do not have the same enforceability as national laws and regulations; the FESIA and the SESIA will ensure the project is in line with national, regional and local strategies. Several policy papers have been taken into consideration in the assessment of social and economic impacts, including the 2012-2016 Country Strategy Paper, which supports the development of green infrastructure (including solar) as one of its focus, and the Strategy for the Social and Economic Development of the Region of Souss Massa Draa 2011-2015.

Several areas of the IFC Performance Standards are relevant for this chapter, in particular:

- Performance Standard 2: Labour and Working Conditions
- Performance Standard 4: Community Health, Safety and Security
- Performance Standard 5: Land Acquisition and Involuntary Resettlement

### **Traffic and Transport**

Due consideration is given in this chapter to the recommendations set out within the IFC General EHS Guidelines Section 3.4 Traffic Safety, within Section 3: Community Health and Safety. In addition, the following national laws have been considered:

- Decree No. 2-03-169 of 22 Muharram 1424 (26 March 2003) on the transport of goods by road;
- Law 52-05 relating to traffic.

A draft law on road transport of dangerous goods has been passed in parliament in the first week of November 2012. According to the legislation, these goods must be transported by vehicles or trailers appropriately equipped. The characteristics of these vehicles must be established by a statutory instrument, which will in turn respect those outlined in the European Agreement concerning the International Carriage of Dangerous Goods by Road (ADR).

### **Cultural and Heritage**

*National*

Dahir 1-80-341 of the 17 of Safar 1401 (25th of December 1980) on the promulgation of law 22-80 on the conservation of historical monuments and of historical sites, inscriptions and art objects.

Dahir 1-06-102 of the 18 of Joumada 1 1427 (8h of June 2006) on the promulgation of law 19-05 modifying law 22-80 on the conservation of historical monuments and of historical sites, inscriptions and art objects.

#### *International*

In accordance with the Equator Principles' requirements for projects located in non-OECD countries or countries that are not listed as developed OECD countries (as defined by the World Bank Development Indicators Database), the assessment has referred to applicable International Finance Corporation's (IFC) Performance Standards on Social and Environmental Sustainability, specifically, Performance Standard 8 – Cultural Heritage.

#### *International Conventions*

Morocco is one of the signatory parties to the World Heritage Convention. The most significant feature of the Convention is that it links together the concepts of nature conservation and the preservation of cultural properties. It defines the kind of natural or cultural sites that can be considered for inclusion on the World Heritage List. It recognises the way in which people interact with nature, and the fundamental need to preserve the balance between the two.

#### **Landscape and Visual**

While the determination and classification of a landscape and a visual impact is largely a subjective interpretation, the general definition for each can be described as:

- Landscape impacts result with changes in the fabric, character, and quality of the landscape as a result of a development; and
- Visual impacts relate to changes in available views of the landscape, and the effect of those changes on people.

No standards exist with regard to landscape or visual impact in the guidance. In the absence of specific standards with regards to landscape or visual impact, the existing visual characteristics of the Project site have been assessed using professional judgment and experience.

---

### 3 PROJECT DESCRIPTION

#### 3.1 Key Project Objectives

The Moroccan Agency for Solar Energy (MASEN) has proposed to construct a solar power complex in Ouarzazate to meet several national policy objectives, namely law No. 13-09 regarding renewable energy. The proposed project represents the second phase of the 500MW Solar Power production complex in the Ouarzazate Region. This renewable energy project would meet the following key objectives of this law:

- to reduce the oil-dependency and energy imports of the Kingdom of Morocco;
- to diversify the sources and resources of energy production;
- to use an indigenous natural resource; and
- to reduce CO<sub>2</sub> emissions to the atmosphere.

#### 3.2 Location of the Project Site

The proposed NOORo II CSP project is located within the commune of Ghassate, on the Tamzaghten Izerki site, on a 612ha plot, as shown in the figure below. The proposed plant will be located 10km northeast of the City of Ouarzazate and approximately 20km north of Mansour Ed Dahbi Dam.

The subsequent table provides the boundary coordinates of the site, and the Figure 2-3 provides the layout of the proposed project.



**Plate 3-1 NOORo II CSP location**



**Table 3-1 Centre Co-ordinates of the Project**

Latitude	Longitude
31° 2'6.31"N	6°52'8.34"W

**Plate 3-2 Project Layout – General**



Plate 3-3 Project Layout – Power Island

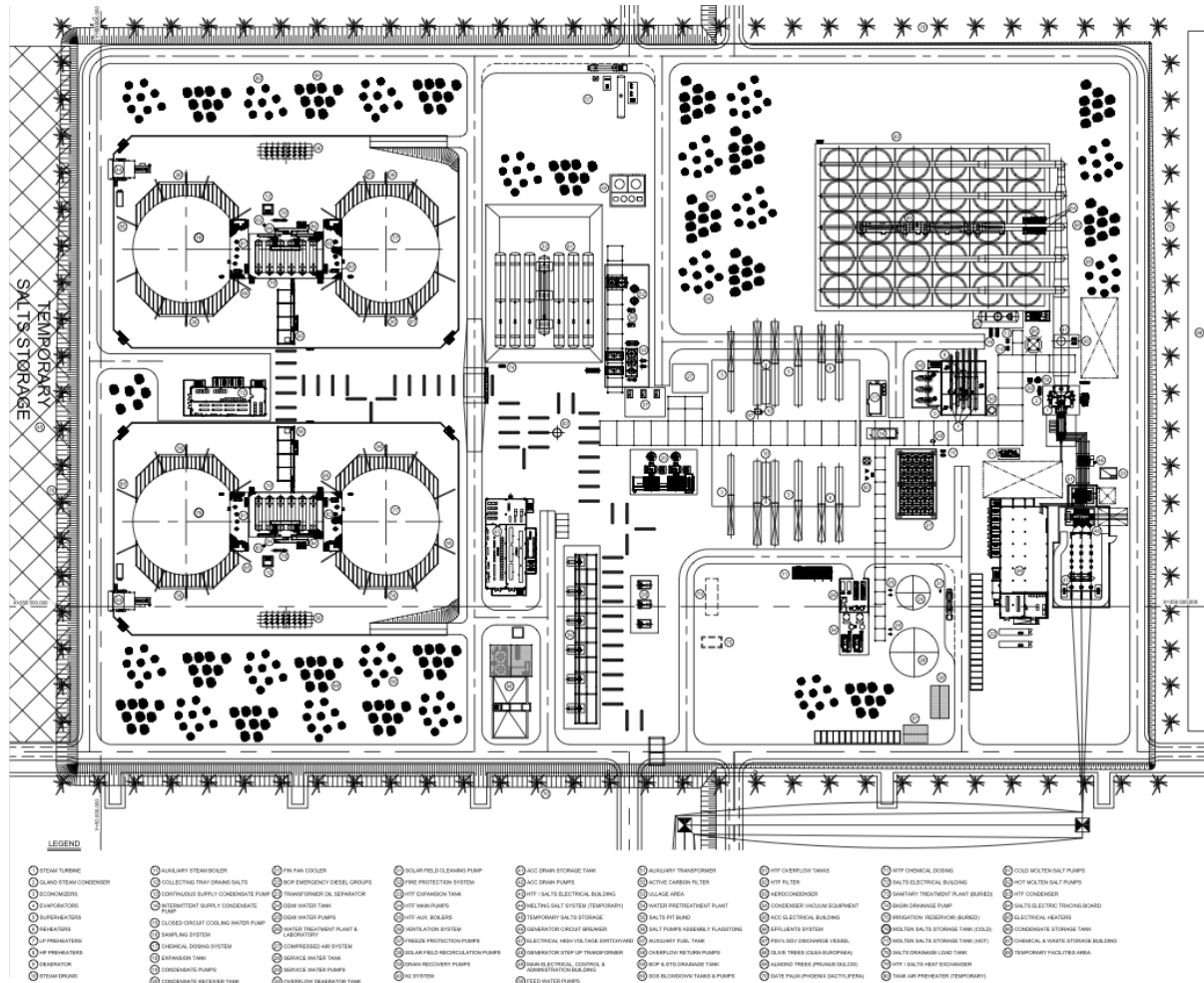

### 3.3 Site Condition and Land Use

The proposed project is located on a sparsely vegetated and flat rocky plateau, which is crossed north to south by Chaabas. The Chaabas support a relatively higher biodiversity than the remaining areas of the site, as the vegetation is denser on the edges of the Chaabas. To the west and east of the proposed project site are deep canyons and lateral Chaabas.

Construction of a dedicated access road on the eastern boundary of the 500MW SPC complex was started for Phase 1 of the complex. This now completed road also connects to the village of Tasselmant, north of the SCP complex.

Prior to construction of Phase 1 of the SPC, the plateau was used by nomads for cattle grazing, even though the grazing quality was not exceptional. However since the start of construction, access to the specific grazing fields within the NOORo II project boundary have



been restricted. Equally, at no time in the past nor present have any permanent establishments been identified within the boundaries of the entire plateau.

Further discussion of the environmental characteristics of the NOORo II project area which are relevant to the assessment of environmental impacts are provided in the Chapters 5 to 15.

**Plate 3-4 Sparsely vegetated plateau**





**Plate 3-5 Chaaba running through the site**



**Plate 3-6 Canyon to the west of the site**





### 3.4 Key Sensitive Receptors

The main socio-economic sensitive receptors are the city of Ouarzazate, the regional villages and arable lands to the east and northeast of the project site, namely Tasselmant, Tiflite, Igherm Amellal, Tidgheste, Taferghouste, and the nomadic pastoralists that cross the site with their herds.

The ecological sensitivities are the Mansour Ed Dahbi dam and canyons situated to the east and the south of the site. The stability of the canyons may be affected by the project drainage and become subject to increased erosion rates or increased flood risks; and consequently, the Dam would be susceptible to any increased siltation or pollution resulting from significant changes in the drainage regime of the site.

Figure 3-5 maps the locations of the identified social and environmental sensitive receptors.

#### **Plate 3-7 Village of Tasselmant, north-east of the site**



**Plate 3-8 Mansour Ed Dahbi Reservoir**





**Figure 3-1 Identified Sensitive Receptors**



### 3.5 Project Alternatives

Under Moroccan and international guidelines for environmental impact assessments, the evaluation of various project design and activity alternatives were considered, in order to ensure that the objectives of the proposed project have accounted for social, ecological, economic and technological options.



---

The following project alternatives are discussed in this chapter:

- No Project
- Alternative solar power production technologies
- Alternative project location and layouts

### **No Project**

The “No Project” option is not a viable alternative, as the objective of the renewable energy law is to diversify the sources and production measures of power for the Kingdom of Morocco. Therefore, the development of NOORo II CSP ensures that the target of providing 25% of 2000MW national production by 2020 is maintained.

Equally, Phase 2 of the proposed solar power complex provides opportunities to develop technological and engineering expertise in the field of solar production.

Finally, from a national perspective, the production of energy via renewable measures will elevate the country's profile at the international level.

### **Alternative solar power production technologies**

The Framework Environmental and Social Impact Assessment (FESIA) that was carried out in January 2011, identified and assessed four technologies for solar power production in relation to ecological and social settings of the proposed site. The alternative technologies considered included: Photovoltaic without tracking devices, photovoltaic with tracking devices, solar power tower with solar farm, and parabolic trough solar field.

The concentrated solar power field with tower would result in a significant visual impact as the 100-150m tall tower would be visible from the city of Ouarzazate. With regards to the photovoltaic option, this technology would not allow for storage of power, nor generation of power during low solar irradiance and night time, therefore additional conventional methods for generating power would be required to meet demand.

Consequently, the parabolic solar power field was identified as the preferred choice, as power could still be generated during lower solar irradiance, and the visual impact was minimal and localised.

### **Alternative project location and layout**

The location of the NOORo II CSP is restricted at the southern and northern boundaries by the under construction NOORo 1 and proposed future NOORo III tower CSP, respectively. Furthermore, the eastern boundary of the site abuts the newly built access road, and any possible shift to the west is prevented by the presence of the Chaabas and canyon. As such,

any possible shifts of the project boundaries within the provided area for the three phases of the SPC complex is very limited.

With regards to the seasonal pastoralists that used to cross the site occasionally with their herds and cattle, it is considered that the impact will be of minor negative significance giving the low quality vegetation for grazing in the area of the Ouarzazate Complex due to sparse vegetation.

The passage and grazing of herds may be done through a route in the north and north-east of the site.

### **3.6 Project Design**

A Thermoelectric Solar Power Plant is an electricity generation system based on a low temperature Rankine cycle. The second phase of the Solar Power Complex will use a solar field of approximately 1,675,200 m<sup>2</sup> of parabolic-trough collectors to generate thermal energy, and will consist of a thermal energy storage system based on molten salts and a steam cycle of 200 MW to generate electricity.

Using the field of parabolic-trough collectors the solar radiation is concentrated on a Heat Collector Element (HCE), located at the focus of the parabola, which is filled with Heat Transfer Fluid (HTF). This HTF is heated to 393°C as it circulates through the receivers and returns to a series of heat exchangers, the Steam Generation System (SGS) in the power island, where the HTF is used to generate high-pressure superheated steam (380 °C and 105 bar). This steam is then used by a high-pressure steam turbine to generate electricity.

At the outlet of the high- pressure turbine, the steam is reheated in the SGS and the hot reheated steam is fed to the low-pressure turbine. The low-pressure turbine outlet steam is condensed transferring the residual heat to an air-cooled condenser. The condensed water is pumped through a system of preheaters and a de-aerator and returned to the SGS. The steam cycle will be balanced with a dry cooling system, which will reduce the water consumption of the plant to the minimum quantity. This is an important improvement in the design compared to NOORo 1 that used wet cooling. The lower water consumption reduces water abstraction from the reservoir, that is used for several competing uses and is a designated RAMSAR site.

Once the HTF has passed through the heat exchangers, the cooled HTF is returned to the solar field and the cycle is repeated.

During the summer months the plant can be expected to operate on solar energy for 10 to 12hrs a day. During Peak Hours (high electricity demand with conditions of low or no solar radiation) an energy storage system consisting of two molten salt tanks will be used to

generate steam for the turbines. The energy storage capacity of the molten tanks will be equivalent to 6 hours of operation at 85% of full load of the steam turbine.

Therefore, the plant will be designed to generate electricity whilst also loading the Thermal Energy Storage (TES). The heat contained in the HTF will be transferred to the Molten Salts Fluid tank through the HTF/Salts Heat exchanger. The molten salts fluid will be pumped from the Cold Tank to the Hot Tank through this Heat Exchanger and the thermal energy will be stored in the Hot Tank. With this energy it is possible to produce electricity after sunset.

After sunset, the operation of the solar field is shut down and the download from the thermal storage begins. The thermal load of the hot salts is transferred to the HTF in the HTF/Salts heat exchanger and into the SGS to maintain the electricity production in the turbine- generator.

Finally, in order to prevent the molten salts and thermal oil from freezing during non-operation periods, auxiliary boilers will be installed to maintain the minimal temperature needed for both liquids. The auxiliary boilers, in addition to their operation for non-freezing functions, may also be used to produce steam in the SGS in order to support the synchronization of the turbine.

**Figure 2 7 Basic Plant Process Sketch**

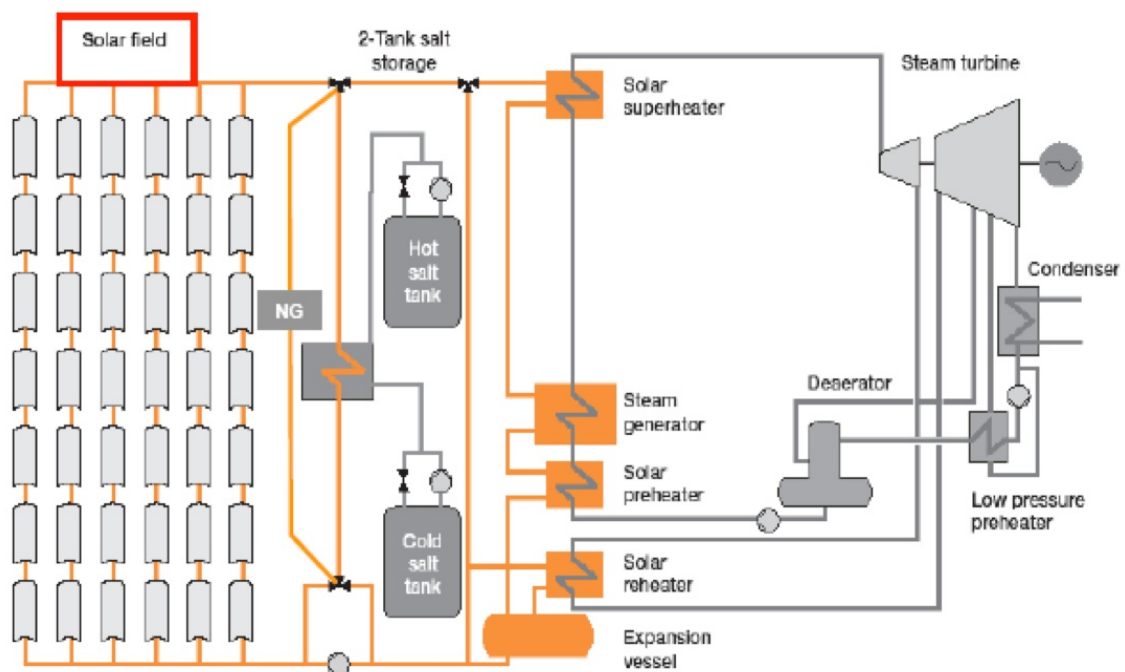

### 3.6.1 Plant Operation Modes

Based on the time of day and solar radiation capacity, the plant will be designed to operate in the following standard modes.

#### MODE 1 - THERMAL OIL HEATING SYSTEM

Thermal Oil is heated up with the energy from the Solar Field. The purpose of this mode is to heat the HTF hot flow throughout the system until it reaches the temperature at which oil can be conveyed to the heat exchangers and steam generation system or to the thermal energy storage system.

#### MODE 2 – HEAT TRANSFER FROM THE SOLAR FIELD TO THE STEAM GENERATION SYSTEM

When there is enough solar irradiation to operate the Steam Turbine but no excess energy to send to Thermal Storage or when Thermal Storage is completely charged.

The HTF Main Pumps will pump the HTF from the Expansion Vessel through the Solar Field, to the Steam Generation System, and back to the Expansion Vessels.

#### MODE 3 – HEAT TRANSFER FROM THE SOLAR FIELD TO THE STEAM GENERATION SYSTEM AND THERMAL ENERGY STORAGE

When the solar irradiation is enough to keep the Steam Turbine at the desired load and to send excess energy to Thermal Energy Storage.

The HTF Main Pumps will pump the HTF from the Expansion Vessel through the Solar Field, to the Steam Generation System or the HTF/Salt Heat exchangers (in a parallel way), and back to the Expansion Vessel.

The Cold Salt Tank Pumps will pump the salt from the Cold Tank, through the HTF/Salt Heat exchangers, to the Hot Tank.

#### MODE 4 – HEAT TRANSFER FROM THE SOLAR FIELD TO THE THERMAL ENERGY STORAGE

When there is low solar irradiation and it is preferable to store energy from the Solar Field in the Thermal Energy Storage system for later use (at a higher load and optimum efficiency) instead of producing electricity in the Steam Turbine at lower loads and low efficiency, or when the Steam Turbine is not available.

The HTF Main Pumps pump the HTF from the expansion vessel, through the solar field, to the HTF/Salt heat exchangers (by-passing the Steam Generation Trains), and back to the Expansion Vessel.

The Cold Salt Tank Pumps will pump the salt from the Cold Tank, through the HTF/Salt heat exchangers, to the Hot Tank.

#### MODE 5 – HEAT TRANSFER FROM THE SOLAR FIELD AND THERMAL ENERGY STORAGE SYSTEM TO STEAM GENERATION SYSTEM

When the energy coming from Solar Field is not enough to keep the Steam Turbine at the desired load and there is energy available at Thermal Storage.

The HTF Main Pumps pump the HTF from the Expansion Vessel to the Solar Field and the HTF/Salt Heat exchangers, in parallel, and then to Steam Generation System and back to the Expansion Vessel.

The Hot Salt Tank pumps will pump the salt from the Hot Tank, through the HTF/Salt Heat exchangers, to the Cold tank.

The Solar Field will capture the maximum available energy, and Thermal Storage will supply the additional energy demanded by the SGS. One control valve at the Solar Field inlet and one control valve in the HTF side of the Thermal Energy Storage will work together as a split-range to distribute HTF flows between Solar Field and Thermal Energy storage as necessary.

#### MODE 6 – HEAT TRANSFER FROM THERMAL ENERGY STORAGE TO THE STEAM GENERATION SYSTEM

When there is no available energy from the Solar Field but there is available energy from Thermal Storage.

The HTF Main Pumps pump HTF from the Expansion Vessel to the HTF/Salt Heat exchangers and from here to the Steam Generation System, and back to the Expansion Vessel.

The Hot Salt Tank Pumps will pump the salt from the Hot Tank, through the HTF/Salt Heat exchangers, to the Cold Tank.

The Solar Field Recirculation Pump will be put into operation in order to avoid freezing in the Heat Collecting Elements of the Solar Field Loops.

The HTF flow will be adjusted to meet the thermal power demand of the SGS. Hot salt flow will be adjusted to attain target hot HTF temperature for this mode.

#### MODE 7 - PLANT SHUT-DOWN

This is a transit mode which can appear for a short or long Plant halt, when there is no solar resource, TES is exhausted, under certain alarms or adverse ambient conditions, even in cases of planned outages.

The Thermal Oil circulation through HTF system may be stopped. The HTF heating pumps and the HTF heaters must be stopped and the lines to SGS and TES must be closed.

During a short shutdown period, it is recommended that pressure be maintained in the steam system, in order to facilitate start-up. Therefore, the auxiliary steam boiler for turbine sealing must be operated.

If Plant shutdown occurs, MODE 8 must be implemented in order to prevent an unsafe situation due a low temperature in the solar field.

## MODE 8 – FREEZE PROTECTION

This mode will be selected after Plant shutdowns, when there is no solar irradiation and no Thermal Storage operation. This mode tries to avoid excessive HTF cooling.

One Freeze Protection Pump will pump the HTF from the Expansion Vessel, through the HTF heaters, to the Solar Field, and back to the Expansion Vessel, by-passing the Steam Generation System and the HTF/Salt heat exchangers.

Circulation is not continuous and is operated in short time intervals, in order to achieve a homogenous temperature distribution in the HTF. Without this circulation, HTF in certain portions of the system could approach freezing temperature while the HTF in the rest of the system remains warm.

### **3.7 Main Complex Facilities**

#### **3.7.1 Heat Transfer Fluid (HTF) System**

The HTF system is in charge of receiving and transferring the solar energy obtained in the solar field to the Steam Generation System (SGS) and the Thermal Energy Storage (TES). This closed loop is divided into various subsystems that carry out different tasks, as described below.

##### Solar Field

The Solar Field will consist of 400 loops, with each loop comprising of four (4) connected Solar Collector Assembly (SCA) modules. Each of the SCA will contain up to twelve (12) Solar Collector Element (SCE) modules, through which the HTF is circulated and heated by solar radiation. The solar collectors will be capable of heating the HTF to a range of 297 °C to 393°C. The heated HTF is eventually carried to the Power Island to be fed into the SGS and TES.

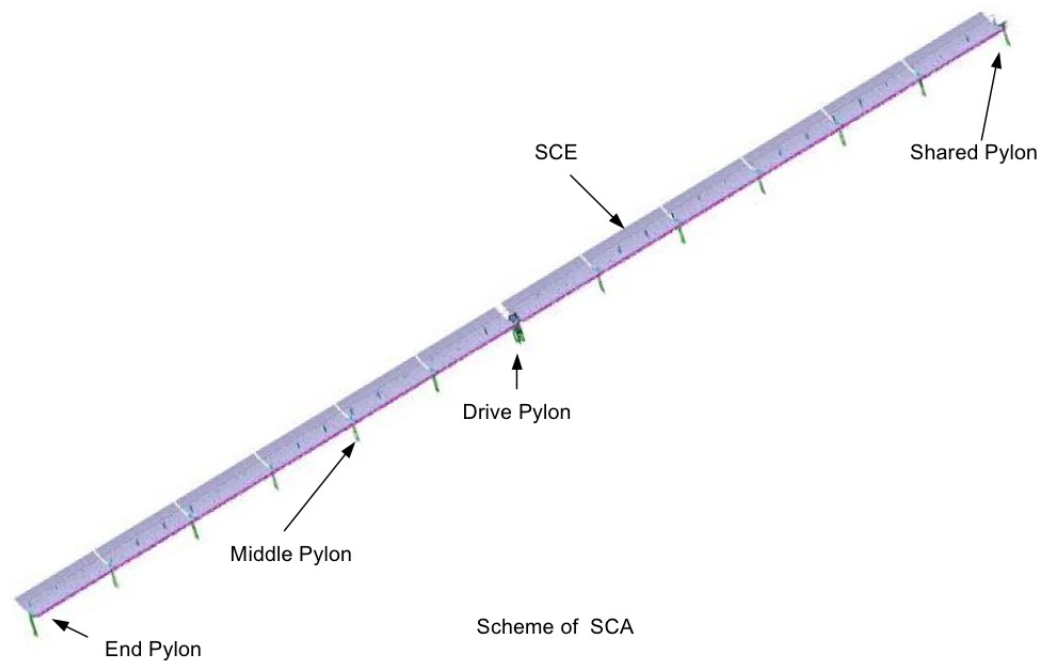

### HTF Pumps

The HTF is pumped throughout the field and the Power Island by the HTF pump.

### HTF Expansion and Overflow

During the thermosolar plant operation the HTF is subject to both thermal expansion and contraction. The expansion and overflow system buffers the volume changes of the HTF due to heating or cooling. The expansion tank is also used for top-up and temporary HTF storage during maintenance of the circuit. The system consists of:

- One expansion tank and six overflow tanks;
- A Nitrogen system is used to inert and pressurize the expansion and overflow tanks and the main HTF circuit in order to ensure that the oil circuit is always kept above the oil's boiling pressure and the oil flows in liquid state;
- A venting system is used to release the thermal oil vapours and nitrogen out of the Expansion and Overflow Tanks, and the gases are conducted to the Thermal Oil Condensation and Purification System under controlled pressure; and
- A Thermal oil filter is used to continuously clean the thermal oil.

### HTF Heating

The HTF Heater system is made up of two Thermal Oil Heaters, which guarantee that the oil's temperature will be maintained above 70° C to prevent deterioration from oxidation and potential freezing during long non-production periods. The Thermal Oil Heater capacity will

be 85 MWt in order to provide the necessary energy to produce the steam required to synchronize the turbine. These boilers will burn light fuel oil (LFO), and will have a common exhaust stack. The flue gas stack will include sample points for the temperature analysis and control of the combustion smoke. Boiler emissions will include: SO<sub>x</sub>, NO<sub>x</sub>, PM<sub>10</sub>, CO<sub>2</sub> and CO.

#### HTF Condensation and Purification (Ullage system)

The main function of the HTF condensation and purification system is to condense the HTF vapour that is vented from the expansion system and to purify the HTF in order to avoid the accumulation of oil's degradation products within the oil circuit.

The condensation process consists of two consecutive condensation tanks, which are used to separate the nitrogen from the vaporized HTF in the expansion tank vent. The HTF is recovered (i.e. condensed) by lowering the temperature using air-coolers. Liquids from the condensation tank are drained into a tank for safe disposal. The vent of the condensation tank is equipped with an active carbon filter to avoid emissions of volatile compounds (VOC) to the atmosphere.

During the life of the Plant, the HTF will degrade. Consequently a Purification System will separate the heavy degraded compound, 'low boilers', from the HTF. This is achieved by passing the HTF through a Flash Tank, which creates a purified gaseous phase and a liquid phase. The liquid will be rich in degraded compounds and subsequently eliminated from the system.

### **3.7.2 Steam Generation System**

The Steam Generation System (SGS) of the power Plant will consist of a regenerative Rankine cycle (5+1 extractions) with two parts at two pressure levels with intermediate reheating. With a nominal load of 00 MW, the characteristics of the steam in the turbine inlet are the following:

- High Pressure Intake Body (HP): approx. 105 bar (a), 380 °C
- Low Pressure Intake Body (LP): approx. 17.4 bar (a), 380 °C

The energy captured in the solar field will be used to produce steam, which will be sent to the turbines to produce electricity.

The feed water sent to the Steam Generation System is heated in the Economiser, converted into steam in the Evaporator and superheated in the Superheater, producing main steam at 380 °C that is sent to the high-pressure body of the steam turbine.

Subsequently, the cold reheat steam is sent to the Reheater of the SGS to obtain hot reheat steam, which is then sent to the low-pressure body of the steam turbine. Finally, the steam



exiting the low-pressure outlet is conducted to the air cooled condenser, where the cycle is repeated.

#### Dry Cooling System & Condensation System

The main function will be to extract and condense the steam from the Low Pressure Steam Turbine. The steam condensation function is achieved by ceding latent heat from the steam turbine exhaust steam (or the bypass stations, as applicable) to the fan-driven air, for which reason the equipment is known as an air-cooled condenser.

The Dry Air Cooling System, in this case Air Cooled Condensers, consists of several modules of A-shape steel frames supporting the fin tube bundles sitting on a raised steel leg system to allow proper forced draft air intake.

The turbine exhaust steam flows through a main steam duct to the inlet of the fin tube bundles and is cooled by air moved by axial fans which are installed on support structures beneath the fin tube bundles. Fans are driven by electric motors coupled with speed reducing gearboxes. The fans are located within fan rings and move the cooling air through the fin tube bundles.

Cooling air absorbs the energy from the condensing steam in the fin fan bundles and leaves the installation as warm air at the exit of the fin tube bundles. Condensate from the fin tube bundles is collected in condensate headers located at the bottom end of the fin tube bundles and flows by gravity to the main condensate tank (condensate receiver tank), which is located below the level of the A-frame but high enough to provide sufficient NPSH to the main condensate pumps that are generally located at ground level. The condensate pumps return the condensate to the water cycle.

- No water consumption during normal operation. It does not generate blowdown or waste water.
- Water is consumed only during cleaning and holding operations (Approx. one cleaning /year)
- Cleaning: 20-22 m<sup>3</sup> water per fan (170 l/min, 2-2.5 h/fan) at dust soiling. (Approx. 36 fans )

#### Thermal Energy Storage (TES)

The main function of the Thermal Energy Storage (TES) is to store the thermal energy in order to extend the operation of the plant during Peak Hours by providing thermal energy when there is not enough solar energy available to run the plant at full load.

The main components of this system are the Storage Tanks, one for cold salts and the other for hot salts, the cold and hot salts pumps and the HTF/Salts Heat Exchangers.

The molten salt is a mixture of Sodium Nitrate and Potassium nitrate, commonly called saltpeter. Molten salt has a high heat transfer coefficient and high thermal storage capacity.

### **3.7.3 Balance of Plant (BOP)**

#### Raw Water System

Raw water supply to the Plant will be delivered from a water storage tank common for the NOOR Solar Power Complex. During the Plant construction period this tank will not be available; raw water for construction will be supplied from the water reservoir Mansour Ed Dahbi.

The raw water treatment system will be designed to optimize the global raw water consumption, which will be used by the following facilities:

- Steam/water cycle make-up water
- Closed cooling loop make-up water
- Mirror cleaning water
- Service water

Major components of the raw water treatment plant system will include the following:

- Pretreatment of raw water: disinfection with hypochlorite, coagulation-flocculation, flotation-clarification and sand filtration bed. The sludge will be thickened and dehydrated in a centrifuge for subsequent off-site disposal at the Ouarzazate municipal waste treatment facility.
- Demineralization plant: the treated water will then be sent to a polishing system, which will carry out chemical conditioning, microfiltration, a second step of reverse osmosis and finally electro deionization.

Pre-treated or filtered water will be used as: Tempering water, Service water, Drinking water, Reverse osmosis feed, and cooling tower direct make-up.

Demineralized water will be used for water-steam cycle make-up (water supply to the condenser and the degasser) and for mirror cleaning in the solar field.

Potable water will be supplied to the Plant from an external network; it will be stored and distributed to the consumers in the plant.

The design, installation and operation of all aspects of the system will comply with the relevant local and national codes, directives and regulations and be in accordance with recognized international standards.

### Wastewater Treatment Facilities

The waste water system will be designed as a zero liquid discharge system. The wastewater streams will be separated according to their origin and/or type of pollution and the type of treatment that they require. The following separate treatment systems will be provided:

- Oily waste water treatment system: All oily waste water (including rainwater or any other surface water flows from areas likely to be contaminated) will be treated by an oil-water separator;
- Industrial and process water drainage system: All industrial and process related waste water such as cycle blowdown, rejects from demineralization plant, from rinsing and flushing processes, from chemical storage areas and workshops etc. will be treated in a wastewater treatment plant, that will be adequately and suitably designed to neutralize the wastewater; and
- Sanitary and domestic waste water: Sewage and sanitary wastewater drainage from the entire plant area will be collected in a sanitary and domestic drainage system and discharged to the wastewater treatment plant. Before entering the wastewater treatment plant, this effluent will pass through a biological treatment in order to oxidize organic matter. The design of the sewage treatment plant will be according to the environmental regulations in Morocco.

All treated wastewater is sent to the homogenization and neutralization pool, and finally to the evaporation ponds.

**Table 3-2 Predicted Water Consumption and Wastewater Generation**

<b>Annual Water Consumption</b>	<b>280,000m<sup>3</sup>/year</b>	<b>41.5m<sup>3</sup>/hr</b>
General service water	850 m <sup>3</sup> /y	-
Demineralized water for mirror washing	50,800 m <sup>3</sup> /y	
Demineralized water for cycle make-up	79,900 m <sup>3</sup> /y	
Treated (RO) water for air-cooled condenser washing	8,800 m <sup>3</sup> /y	
<b>Effluents</b>		
Water treatment system rejection	116,800 m <sup>3</sup> /y	-
Net discharged effluents (system losses)	22,850 m <sup>3</sup> /y	
Wastewater Discharge	206,500m <sup>3</sup> /y	66.5m <sup>3</sup> /hr peak discharge
<b>Wastewater quality</b>	Temp - 35C 7.6pH Conductivity 5,200µS/cm	

### Sampling System

Water analysis will be carried out by either automated continuous systems or manually on a regular basis to verify optimum operations and ensure compliance with relevant regulations.

The following systems will be monitored: BOP water, auxiliary boiler, steam generation system, water treatment plant, and HTF system.

The main parameters that will be analysed are:

- Ph
- Conductivity
- Dissolved oxygen
- Sodium
- Silica

### Evaporation Ponds

Two evaporation ponds have been designed to collect the effluent from the plant. They will be located to the south of the site.

The selected typology for the standard cross-section is for a height of 1 m. The ponds will be allowed to fill to a depth of 0.5 m, with a reserve of 0.50 m. The inner and outer embankments of the ponds are 2H:1V.

The ponds will not be filled from any other sources than those regulated from the plant and any direct rainfall over the surface area. In order to eliminate excesses, an overflow with an effluent threshold will drain into a perimeter channel.

The standard cross-section consists of two impermeable geo-membrane made from high-density polyethylene (HDPE) 1.5 mm thick, laid over a geo-textile sheet on the face in contact with the membrane and a draining layer below. This item is fitted over a layer of sand layer 0.15 m thick on the embankments and on the base. Impermeability of the ponds is accomplished through the use of a high density polyethylene (HDPE) geo-membrane sheet 1.5 mm thick.

The evaporation surface areas of each pond are as follows.

**Table 3-3 Evaporation Pond Areas:**

Pond No.	Evaporation Area (m <sup>2</sup> )
1	35,650
2	35,650
<b>TOTAL</b>	<b>71,300</b>

### 3.7.4 Auxiliary Systems

#### Chemical Dosing System

Chemical dosing of the fluids circulating through the cooling system, steam generation and turbine systems will be carried out, in order to maintain pH levels, oxygen content, remove excess salts, and ensure general good water quality characteristics within the manufacturer's technical parameters.

The following chemicals may be used: alkaline solutions (sulphuric acid), deoxygenating agents, Tri-sodium Phosphate, corrosion inhibitors and anti-fouling agents (Sodium hypochlorite).

#### Auxiliary fuel system

The fuel system will not be used to complement the energy production during low or no radiation periods. Instead, the diesel fuel will be used in the following plant processes, either as the main source or for back up to ensure safe operation of the CSP plant:

- Support for starting up for the minimal turbine technical load (up to synchronization)
- Maintaining the minimal temperature of the HTF when there is no solar radiation
- HTF Boilers efficiency
- Thermal power for stand-by
- SGS nominal power.

The predicted annual consumption for LFO will be 78,033MWh/y

#### Auxiliary Cooling System

The purpose of this cooling system will be to facilitate the evacuation of non-useful heat that will be generated by the auxiliary equipment, such as: electric generator coolers, air compressors coolers, feedwater pumps, condensate pumps, thermal oil pumps, etc.

The system will consist of a closed cooling circuit, which will have two horizontal pumps 2x100% circulating the water through the Plant Auxiliary Systems (ST Lube Oil and Generator, Feedwater Pumps, Main and Auxiliary HTF Pumps, etc). The Closed Cooling Circuit will be cooled by one fin fan coolers set, designed for the ambient conditions.

#### Other Auxiliary Systems

- Compressed Air System: Will supply instrument air and service air to different components of the CSP Plant.
- Blanketing System: Will minimise risks due to flammable products, minimise emissions to the atmosphere and will prevent deterioration of certain sensitive equipment.
- Fire fighting System

- HVAC system
- Electrical Systems
- Plant Control Systems /Distributed Control System

### **3.8 Construction Phase**

#### **3.8.1 Construction Activities**

The following series of works will be undertaken in association with the Project:

##### Preparatory Works

- Site surveys and site preparation & development;
- Infrastructure works; and
- Construction facilities.

##### Civil Works

The platform has an extension of approximately 6,400,000 m<sup>2</sup>, and an approximate length of 2,800 m from north to south and 2,300 m from east to west

A “cut and fill” plan will be generated to ensure that the site's platform follows the natural incline of the plateau. The platform will be distributed in 8 levels, where the difference in maximum height between two adjacent levels will be 4.35m. The levels don't have a descending slope from north to south. A transversal slope of 0.40 % is defined so that waters are spilled to the east side, adapting the platform to the terrain and hence reducing earth movements.

**Plate 3-9 Longitudinal Profile of the Platform**

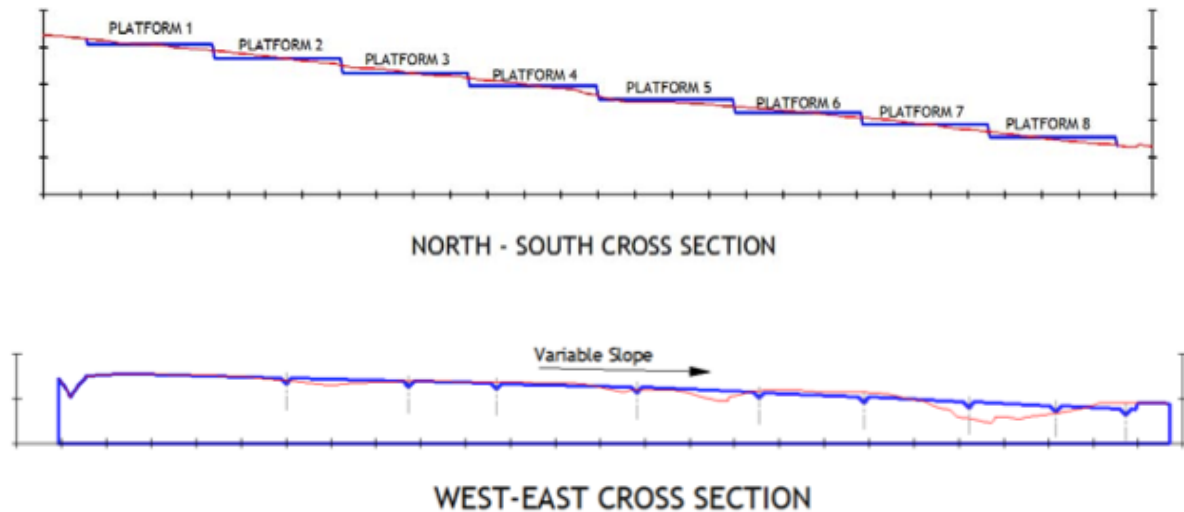

The preliminary geotechnical investigations indicate that general soil improvement will likely not be required. Compaction is expected to be limited to local areas where "soft spots" may be encountered, for road construction and backfilling to foundations.

Excavation methods will be dependent on the ground conditions and the depth of foundations. Therefore either, shallow strip foundation design or shallow / basement raft foundations may be used depending on the technical requirements of the structures. Excavated soil will be reused where possible.

The need for piling will be determined on completion of the final site investigation. Piling techniques will be dependent on ground conditions, and could include bored, cast in situ and/or driven piles.

In accordance with normal construction practice in Morocco, the superstructure construction system may be concrete frame with concrete block work infill or steel frame with insulated panels. Steel framed structures will generally be used for the longer span "industrial" buildings and buildings that house the process equipment.

### **3.8.2 Construction Materials**

Construction materials will be sourced locally where possible. Materials available locally include:

- Ready mix concrete;
- Concrete Products, road kerbing and paving etc.;

- Steel reinforcement;
- Building block work;
- Pipework;
- Tiling and finishing products, roof tiles etc.;
- Asphalt products.

Materials that are not sourced locally will be either regionally obtained or as a last resort will be imported from overseas. Local agents will be used wherever possible for sourcing mechanical and electrical plant and machinery. High quality finishing products may be imported if they are not available locally.

### **3.8.3 Construction Logistics**

#### Programme

The construction is expected to last about 25 months from Notice to Proceed, followed by 1 year of optimization and demonstrating performance guarantees to reach Final Commercial Operation.

#### Workers and Facilities

Given the duration of the contract and the volume of construction, it is expected that all workers will live off-site. At the peak of construction it is anticipated that as many as 1,200 workers will be employed on site. The contractors will therefore be responsible for the on site provision of workers services, such as canteens, domestic facilities and transportation.

The canteens will generate putrescible and domestic waste, which will be collected from designated areas for storage and removal to an appropriate municipal waste disposal facility. Additionally, litterbins will be provided around the construction site.

The domestic services will consist of sanitary facilities, including restrooms, water tanks and drinking water. All liquid sanitary facilities will drain to a centralized septic tank collection system, which will be emptied on a regular basis and transported off-site for disposal.

Finally, the contractors will be required to transport the work staff between a central location and the project site. Consequently, traffic will be generated from daily workforce commutes. It is anticipated that buses, vans, pick-up trucks and cars will be used for staff commute and equipment transport.

#### Water supply

Contractors will be responsible for the supply of water during construction. A water tank with sufficient capacity to meet construction water needs will be installed on site. Lorries will be used to fill the water tanks.



## 4 SESIA METHODOLOGY

### 4.1 Introduction

The SESIA methodology is specific to each of the technical subjects but includes, as a minimum, a desk study review of available information and standards, on-line information sources, and existing site data and laboratory analyses where available. Detailed site surveys, monitoring and predictive modelling have been undertaken to study baseline situation and predict impacts, and described below for the relevant issues.

### 4.2 Baseline Surveys

Forming an integral part of the SESIA, the baseline surveys provide a benchmark of the existing conditions by which the potential impacts of the proposed NOORo II CSP project can be assessed for construction and operational phases.

The environmental baseline surveys carried out as part of the SESIA have consisted of the following:

- Site walkover survey – May 2014;
- Terrestrial ecology baseline survey – May 2014;
- Noise baseline survey – February 2015
- Air Quality Monitoring – February 2015
- Soil sampling survey – May 2014
- Community consultation – February 2015

These surveys are described further within the relevant chapters.

In addition, the following project information has been reviewed within the course of this assessment:

- Framework Environmental Impact Assessment (FESIA) of the Ouarzazate Solar Complex project. January 2011, prepared by Burgeap and Phénixa for MASEN. Original document in French)
- Revised Framework Environmental Impact Assessment (FESIA) of the Ouarzazate Solar Complex project. June 2014, prepared by Burgeap and Phénixa for MASEN. Original document in French.
- Environmental Impact Assessment of the development of the Ouarzazate Solar Power Complex. February 2012, prepared by Phénixa for MASEN. Original document in French.

- NOORo II Parabolic Trough Project Solar Minimal Functional Specifications. December 2013, prepared by MASEN
- NOORo II CSP – Initial Bid –Technical Proposal. March 2014, Technical Offer prepared by ACWA Power Consortium.
- NOORo CSP Terms of Reference (ToR) for the SESIA. December 2013, prepared by MASEN
- NOORo II CSP Methodological Framework (MF). March 2014, prepared by 5 Capitals.
- WB Integrated Safeguards Data Sheet – Concept Stage (16<sup>th</sup> April 2014);
- AfDB Summary Environmental and Social Impact Assessment for NOORo II;
- CTF Trust Fund Committee - Joint AfDB-WB Submission Document: Morocco: NOORo II&3 Concentrated Solar Power Project, May 2014

### 4.3 Impact Assessment Significance Criteria

In order to obtain a credible assessment of environmental impacts, the assignment of 'impact significance' for each identified impact needs to be a robust, consistent and transparent process. The methodology to assess 'impact significance' is outlined below and follows International Best Practice based on the assumption that the significance of an impact on resources or receptors is considered to result from an interaction between three factors:

- The nature and magnitude of the impact or change;
- The number of resources or receptors affected; and
- The environmental value (sensitivity) of those resources or receptors to the change.

A three-step approach has been used to determine the significance of environmental effects, as follows:

- Step 1 – evaluation of value / sensitivity of resource;
- Step 2 – assessing the magnitude of the impact on the resource; and
- Step 3 – determining the significance of effects.

The magnitude of the impact is defined where possible in quantitative terms. The magnitude of an impact has a number of different components, for example: the extent of physical change, the level of change in an environmental condition, its spatial footprint, its duration, its frequency and its likelihood of occurrence where the impact is not certain to occur.

The criterion that has been used for assessing the magnitude of impacts includes the geographical scale of the impact, the permanence of the impact and the reversibility of the impacted condition. A brief description of the magnitude of the impacts is provided in Table 4-1 below.

**Table 4-1 Criteria for Magnitude of Impact**

Magnitude of Impact	Description of Magnitude
<b>Major</b>	<p>Adverse: Loss of resource and/or quality and integrity; severe damage to key characteristics, features or elements. A major impact is usually large scale, permanent and irreversible.</p> <p>Beneficial: Large scale or major improvement of resource quality; extensive restoration or enhancement; major improvement of attribute quality.</p>
<b>Moderate</b>	<p>Adverse: Significant impact on the resource, but not adversely affecting the integrity; partial loss of/damage to key characteristics, features or elements. Moderate impacts usually extend above the site boundary, and are usually permanent, irreversible or cumulative.</p> <p>Beneficial: Benefit to, or addition of, key characteristics, features or elements; improvement of attribute quality.</p>
<b>Minor</b>	<p>Adverse: Some measurable change in attributes quality or vulnerability; minor loss of, or alteration to, one (maybe more) key characteristics, features or elements. Minor impacts usually are only noticeable within the site and are temporary and reversible.</p> <p>Beneficial: Minor benefit to, or addition of, one (maybe more) key characteristic(s), features or elements; some beneficial impact on attribute or a reduced risk of negative impact occurring.</p>
<b>Negligible</b>	<p>Adverse: Very minor loss or detrimental alteration to one or more characteristics, features or elements.</p> <p>Beneficial: Very minor benefit to or positive addition of one or more characteristics, features or elements.</p>
<b>No change</b>	<p>No loss or alteration of characteristics, features or elements; no observable impact in either direction.</p>

In addition to the factors outlined in the table above, the possibility of any standards being breached will be taken into consideration in the determination of the magnitude of the impact.

The environmental value (or sensitivity) of the resource or receptor has been defined by using the criteria below in Table 4-2.

**Table 4-2 Environmental Value of Receptor or Resource**

Value (sensitivity)	Description of Value
<b>Very High</b>	<ul style="list-style-type: none"> <li>• High importance and rarity on an international scale and limited or no potential for substitution.</li> <li>• The receptor has already reached its carrying capacity, so any further impact is likely to lead to an excessive damage to the system that it supports.</li> <li>• Locations or communities that are highly vulnerable to the environmental impact under consideration or critical for society (e.g. indigenous peoples, hospitals, schools).</li> </ul>
<b>High</b>	<ul style="list-style-type: none"> <li>• High importance and rarity on an national scale, and limited potential for substitution.</li> <li>• The receptor is closed to reaching its carrying capacity, so a further impact may lead to a significant damage to the system that it supports.</li> <li>• Locations or communities that are particularly vulnerable to the</li> </ul>

Value (sensitivity)	Description of Value
	environmental impact under consideration (e.g. residential areas, vulnerable/marginalized groups).
<b>Medium</b>	<ul style="list-style-type: none"> <li>High or medium importance and rarity on a regional scale, limited potential for substitution.</li> <li>The receptor is already significantly impacted, but it is not close to reaching its carrying capacity. Further impacts will get increase the stress of the underlying system, but evidence does not suggest that it is about to reach a critical point.</li> <li>Locations or groups that are relatively vulnerable to the environmental impact under consideration (e.g. commercial areas).</li> </ul>
<b>Low (or Lower)</b>	<ul style="list-style-type: none"> <li>Low or medium importance and rarity on a local scale.</li> <li>The receptor is not significantly impacted and shows a large spare carrying capacity. Impacts are not likely to generate any noticeable stress in the underlying system.</li> <li>Locations or groups that show a low vulnerability to the environmental impact under consideration (e.g. industrial areas).</li> </ul>
<b>Value (sensitivity)</b>	<ul style="list-style-type: none"> <li>Very low importance and rarity on a local scale.</li> <li>The receptor is not impacted and shows a very large spare carrying capacity. Impacts are very unlikely to generate any noticeable stress in the underlying system.</li> <li>Locations or groups that show a very low vulnerability to the environmental impact under consideration (e.g. industrial areas).</li> </ul>

The existence of receptors that are legally protected (e.g. designated areas, protected habitats or species) will be taken into consideration for the assessment of the sensitivity of the receptors.

The significance of effects is a combination of the environmental value (or sensitivity) of a receptor or resource and the magnitude of the project impact value (change). Table 4-3 below shows the criterion used for determining the significance of effects. Definitions of each significance category are provided for in Table 4-4.

**Table 4-3 Criteria for Determining Significance of Effects**

		MAGNITUDE OF IMPACT (DEGREE OF CHANGE)				
		No change	Negligible	Minor	Moderate	Major
ENVIRONMENTAL VALUE (SENSITIVITY)	Very High	Neutral	Minor	Moderate to Major	Major	Major
	High	Neutral	Minor	Minor to Moderate	Moderate to Major	Major
	Medium	Neutral	Negligible to Minor	Minor	Moderate	Moderate to Major
	Low	Neutral	Negligible to Minor	Negligible to Minor	Minor	Minor to Moderate

<b>Very Low</b>	Neutral	Negligible	Negligible to Minor	Minor	Minor
-----------------	---------	------------	---------------------	-------	-------

**Table 4-4 Definition of Significance of Effects**

Significance Category	Criteria
<b>Very Large</b>	Only adverse effects are assigned this level of importance as they represents key factors in the decision-making process. Effects are associated with sites and features of national or regional importance. Effects exceed statutory limits. Mitigation measures are unlikely to remove such effects.
<b>Large</b>	Important considerations at a local scale but, if adverse, are potential concerns to the project and may become key factors in the decision making process. Mitigation measures and detailed design work are unlikely to remove all of the effects upon the affected communities or interests.
<b>Moderate</b>	These effects, if adverse, while important at a local scale, are not likely to be key decision-making issues. Nevertheless, the cumulative effect of such issues may lead to an increase in the overall effects on a particular area or on a particular resource. They represent issues where effects will be experienced but mitigation measures and detailed design work may ameliorate or enhance some of the consequences upon affected communities or interests. Some residual effects will still arise.
<b>Minor</b>	Local issue unlikely to be of importance in the decision-making process. Effects do not exceed statutory limits. Nevertheless they are of relevance in enhancing the subsequent design of the project and consideration of mitigation or compensation measures.
<b>Neutral or Negligible</b>	No effect or effect which is beneath the level of perception, within normal bounds of variation or within the margin of forecasting error. No mitigation is required.

#### 4.4 Consultation Process

The scale and nature of the proposed project and the emphasis that the Equator Principles and associated Performance Standards place upon community involvement or affected parties emphasise this important aspect of the environmental impact assessment process. It is preferable to incorporate the viewpoints of relevant stakeholders in such a nationally and regionally important development and mitigation for the social or environmental concerns of these stakeholders will be incorporated within the design at an early stage as possible.

In Morocco, the public consultation process is well defined under decree no. 2-04-564 and is a pre-requisite to carrying out the SESIA. The procedures and objectives are similar to those defined under the IFC Performance Standards 1, 4, 5, 7 and 8, which ensure that the

development of the Project considers any impacts or practices which may affect local communities or other stakeholders.

Furthermore, Principle 5 of the Equator Principles details that, for all 'Category A' projects, and as appropriate for 'Category A' projects, the Consortium is required to incorporate the communities' concerns.

The site location may have an impact on communities that use the surrounding area on a seasonal or permanent basis, and consultation is key to understanding the existing land use, identifying any community grievances and identifying mitigation measures.

Further details relating to the consultation process that led to the definition of the mitigation measures can be found in the ESMP under the Section 5-11 Consultation Process.

For this project, the public consultation process had already been undertaken in accordance with the procedures outlined for the FESIA preparation. These meetings included:

- First Public Consultation to introduce the project concept. November 3rd 2010.
- Meeting with the CNEIE to discuss the framework of the ESIA. December 10th 2010.
- Public Enquiry for the FESIA was held in September 2011.
- A presentation of the ESIA framework and environmental acceptability was given to the CNEIE. February 22nd 2012.
- Second Public Consultation to provide an update of the ESIA framework. March 6th 2012.
- MASEN provided a presentation of the results of the FESIA on April 24th 2012.
- Public Consultation to introduce the specific environmental impact assessment for NOORo I, November 2012
- Presentation of the revised ESIA framework, June 2014

However, in order to meet the IFI's requirements, additional and project specific public consultation was carried out by Phénixa on February 3rd 2015.

The detailed report of the community consultation meeting is provided in Appendix 1.

The public consultation meeting was advertised through the publication of an advert in French and Arabic national newspapers and the invitation of identified stakeholders in the province of Ouarzazate. The meeting was led by representatives of Phenixa, ACWA Power and MASEN. Local Arabic and Berbere were spoken during the meeting and 76 people attended.

An initial presentation was undertaken to outline the main elements of the NOORo II solar complex, to summarise the environmental baseline on the study area (physical, biological

and human), to outline the positive and negative impacts identified, explain the preliminary assessment undertaken and specify the mitigation measures that were being considered.

The stakeholders present at the meeting consisted of the following:

- 19% of participants were local inhabitants of the Ghassate commune,
- 32% represented different government/administrative bodies such as the Délégation du commerce et de l'industrie, la direction provincial des eaux et forets, l'agence national de promotion de l'emploi et des compétences, la délégation du ministère du tourisme..etc) and
- 12% represented research offices and local private companies,
- 35% were represented by associations.

Considering that extensive consultations had already been undertaken during the FESIA, the attendance to the meeting was considered very positive.

Regarding the content of the points raised in the meeting, 70% were direct questions and 30% were proposals or comments. The following is a summary of the perspectives and concerns of the stakeholders:

- Consumption of water during the operation phases
- Solar flux/rays from the tower on neighbouring communities
- Employment, and
- Concerns about the role of the project in the development of the local population.

The meeting was considered to fulfil its aims, for the following reasons:

- It allowed for precise information to be provided about water use.
- It confirmed that the concerns raised by the population (employment of local people, water use, employment) were in line with the mitigation measures being proposed (e.g. minimal water use, zero wastewater discharges, water treatment for reuse onsite, inclusion of provisions in the CESMP / ESMP to promote the employment of the local population and the provision of training).

## **5 SOIL AND GROUNDWATER**

### **5.1 Introduction**

This chapter assesses the potential impacts to soil resulting from the construction and operation activities of the proposed NOORo II CSP on soil quality.

The relatively undisturbed and undeveloped nature of the sites signifies that the potential for existing contamination to the soils is unlikely. However, the construction phase may potentially increase the risk of contamination through poor site management practices and



inadequate waste disposal management. At the operational stage of the proposed project, the greatest risk of contamination will be from leaks of the HTF over unsealed grounds.

Other general contamination risks are associated with the handling and processing of products where liquid waste and hazardous material can escape into the soil. These are associated with the transport, handling and storage of such materials and the potential threat of releases and spills onto the ground.

## 5.2 Methodology

The assessment of the potential impact of the NOORo II CSP project is based on desktop research as well as actual soil information gathered from the baseline survey, sampling, testing and investigations undertaken for the project area.

In order to develop this chapter, in addition to undertaking a site walkover and subsequent assessment, 5 Capitals has reviewed the following studies:

- Review of relevant guidelines identified within the IFC/World Bank including IFC Performance Standards;
- Review of Dutch Ministry of Housing, Spatial Planning and Environment guidelines for assessing soil; and
- Consultant's research and desktop review.

The desk study includes the assessment of the proposed design, and procedures for construction and operational issues that may impact on both the society and environment. Based on the findings of the assessment, measures have been identified to mitigate any negative effects and promote the positive effects associated with both construction and operational phases (including commissioning of the plant).

As part of the establishment of the baseline soil conditions at the proposed site, 5 Capitals undertook a limited soil sampling and analysis campaign. The sampling comprised the collection of top layer soil samples (at 0.1-0.2m depth) taken at 5 locations, which were then analysed for heavy metals, in accordance to the Dutch VROM standards.

The purpose of the soil sampling activity was to establish a benchmark of the soil conditions at the site, which will be used for the long-term monitoring and environmental management of the site. Particularly if a spill or leak were to occur, the successful clean up procedure would include soil testing for any residual contaminants and the benchmark would be used in the assessment.

**Table 5-1 Soil Sample Locations**

Location ID	GPS Co-ordinates		Comment
	Northing	Westing	
<b>N2 S1</b>	31° 1'48.06"N	6°51'59.04"W	South half of site, within Chaaba
<b>N2 S2</b>	31° 2'4.44"N	6°53'0.18"W	West of the site boundary, down the ravine to wards the Oued
<b>N3 S1</b>	31° 4'6.90"N	6°52'9.06"W	Centre of NOORo III Site, within Chaaba
<b>N3 S2</b>	31° 5'41.10"N	6°51'15.48"W	Agricultural plane of Tasselmant village

**Plate 5-1 Soil Sample Locations**



### **5.3 Baseline**

#### **Geology**

The proposed site is located within the Ouarzazate basin, which is bordered to the north by the foothills of the High Atlas Mountains. The area is characterised by faults and thrust faults, and the southern basin is composed of igneous rock and sedimentary deposits of the Mesozoic, Tertiary and Quaternary period.

#### **Soils**

Within the project site, the soils consist of alluvial and lacustrine/palustrine limestone from the Quaternary period, with the surrounding areas consisting of conglomerates or lacustrine limestone from the Mio-Pliocene period.

Stratigraphic surveys identified the following sequence:

- 0.0 – 6.0 m: Sandy loam with considerable gravel comprising the surface layer.
- 5.5 -16.0 m: polygenic conglomerates with un-cemented successions.
- 8.0 – 16.0 m: a layer of Sandy clay can appear between the conglomerate layers.
- 16.0 – 30.0 m: layer of massive sandstone.
- From 30 m deep: Clayey – marl substrate

The following figures depict the appearance and composition of the soil layers in the Chaabas and ditches located within the proposed site.

**Plate 5-2 Site Soil Profile at Chaaba**





**Plate 5-3 Soil profile within the site**



**Analytical Results**

The following table provides the results for the 4 soil samples collected within the complex boundaries and the village of Tasselmant.

**Table 5-2 Soil Analytical Results (mg/Kg)**

	N2S1	N2S2	N3S1	N3S2	Dutch Target	Dutch Action	CICS Limits *
<b>As</b>	<1.0	<1.0	<1.0	<1.0	<b>29</b>	<b>55</b>	<b>30</b>
<b>Ba</b>	119.0	933.6	91.6	54.1	<b>200</b>	<b>625</b>	<b>500</b>
<b>Cd</b>	<2.0	<2.0	<2.0	<2.0	<b>0.8</b>	<b>12</b>	<b>5</b>
<b>Cr T</b>	25.9	49.1	22.6	14.3	<b>100</b>	<b>380</b>	<b>250</b>
<b>Co</b>	8.9	10.2	7.2	4.7	<b>20</b>	<b>240</b>	<b>50</b>
<b>Cu</b>	20.0	18.8	16.6	13.3	<b>36</b>	<b>190</b>	<b>100</b>
<b>Pb</b>	<1.0	<1.0	<1.0	<1.0	<b>85</b>	<b>530</b>	<b>500</b>
<b>Mo</b>	1.1	1.4	<1.0	<1.0	<b>3</b>	<b>10</b>	<b>10</b>
<b>Hg</b>	<1.0	<1.0	<1.0	<1.0	<b>0.3</b>	<b>200</b>	<b>2</b>
<b>Ni</b>	13.8	11.2	12.9	9.4	<b>35</b>	<b>210</b>	<b>100</b>
<b>Zn</b>	34.8	56.6	27.5	20.3	<b>140</b>	<b>720</b>	<b>500</b>

Dutch Target Value: average background concentration or detection limit; exceeding this value indicates a possible diminishing of the functional abilities of the soil for humans, plants or animals.

(\*): Canadian Indicative Soil Contamination Levels (Québec).

In general the results reveal that heavy metal concentrations at the sample locations are within the Dutch Target values and Canadian indicative values. The only exception is the concentration of Barium at the N2S2 site. This soil sample was collected off-site, from the ravine draining to the Oued on the western side of the site. The soil characteristics were soft, dark red and brown, slightly calcareous, high plastic Clay (SaCl).

The capacity of a soil to retain heavy metals and other contaminants (pesticide, herbicides, hydrocarbons) is based on its clay and organic matter content. Given that the observed soils were predominantly clay composition, and were within the drainage of the Oued, it is likely that the high concentration of Barium is the result of accumulated absorption over the years. Equally, although the concentrations of the other metals, in N2S2, were below the Dutch Target, they are higher than the metal concentrations recorded for the other soil samples, this further indicates that the clay properties of the soil at N2 S2 are acting as a sink and are trapping the natural run off of metals from the plateau.

Therefore, based on the analytical information, historical land use and site observations, it can be concluded that the soils on site are not contaminated by heavy metals.

### **Groundwater**

Within the proposed SPC site, the geologic composition of the rocky plateau consists of tertiary and quaternary formation that is highly permeable and subterraneously inclined. Equally, the Ouarzazate area is characterized by a very low and irregular rainfall (less than 200 mm/year) concentrated in short bursts between long rainless periods. The temperature variations are large and the evaporation rates (2800 mm/year on average) regularly exceed rainfall rates. The Mansour Ed Dahbi dam regulates an annual average contribution of 420 hm<sup>3</sup>, of which Dadès river contributes by 233 hm<sup>3</sup> at Tinouar, and oued Ouarzazate by 145 hm<sup>3</sup> at Amane n'Tini.

Consequently, no groundwater tables or reservoirs are likely present within the project area. In fact, geotechnical surveys identified that on all the performed boreholes, even the deepest ones (50m), the groundwater level was not met.

With respect to the presence of groundwater in the surrounding areas, the nearest village Tasselmant uses artisanal wells for the supply of irrigation water. The depth of these wells ranged from 10m to 14m. Three other wells were identified over 2.5km from the site, however, these wells were much deeper (23m to 26m) and were no longer in use.

## Seismicity

The SPC site is bordered by complex tectonic structure, around the Toundout-Boumalene zone, and is characterised by compression of the faults along a SSE-NNW alignment. These faults and fold run parallel to the massif of the High Atlas and the Anti-Atlas.

A seismicity study, which was undertaken by the consortium, identified that the maximum horizontal acceleration would be an earthquake of 5.6 magnitude, with value  $a_{max} = 0.12 \cdot g$ , for a return period of 50 years with a probability rate of 95%.

Therefore, the site seismic conditions have been taken into account for plant design and the ESMP's Emergency Response Plan has included procedures to be followed in case of earthquake.

### 5.4 Sensitive Receptors

The table below outlines the identified receptors in relation to geology and hydrogeology as well as the determined sensitivity of those receptors.

**Table 5-3 Soil and Groundwater - Receptor Sensitivity**

Receptor	Sensitivity	Justification
Soil	Medium	The site is a greenfield, and no contamination was observed. However natural resources are very limited and only used for low quality grazing.
Groundwater	Medium	Groundwater recharge is low and no aquifers are present within the site. However, neighbouring villages in the valleys rely on groundwater bores for potable water.

### 5.5 Construction Assessment

#### 5.5.1 Initial Impacts

There is a range of construction related activities that could pose a threat and lead to changes in the chemical properties of the soil, resulting in potential contamination. Impacts can occur from the spillage of liquid materials used during construction, improper management of generated construction waste, and cross contamination of soil at the site. Adequate waste management and soil and groundwater protection measures must be outlined in the EPC's CESMP prior to the start of construction activity. These control measures are required in order to prevent the risk of soil and groundwater contamination at the proposed development site.

**Spillage:** During the construction phase, the risk of accidental spillage and leakage of various chemical products, paints, oils, fuels, lubricants, vehicle oil changing or re-fuelling, sanitary wastewater from worker compounds and cleaning agents is present. Impacts of this can take place at the storage areas of the construction site as well as during the



transportation of such materials on site. Improper methods of storing, transferring, and handling of these products can result in spillage to the ground and result in soil contamination. Depending on the volume of the spill and the characteristics of the pollutants, the contamination may reach the groundwater. Once contamination has reached the groundwater, the volume of contaminated soil and groundwater can increase quite rapidly. This is a function of the physical and chemical properties of the contaminants and the velocity of the groundwater. Prior to mitigation, these impacts could be temporary to permanent and be considered of moderate negative significance.

**Waste Management:** Construction of Concentrated Solar Power plants involves activities that generate solid and hazardous waste on-site. Waste generated during these activities poses a threat to the soil and groundwater. Of special concern is the management of hazardous waste generated during the construction phase. Although the hazardous fraction of construction waste such as used oil, machinery lubricants, paints and sludge, represents a relatively small proportion of the total amount of construction waste, it requires special attention. If the temporary storage and handling of such waste on the construction site is inadequate prior to being removed for disposal, the risk of soil and groundwater contamination increases. Prior to mitigation, these impacts could be temporary to permanent and be considered of moderate negative significance.

**Cross Contamination of Soil:** During construction work, cross contamination is the transfer of contaminated earth from one location to another, thereby exacerbating any existing environmental problem through poor management. Currently the general soil conditions on site are good. Soil analysis at the proposed project site was investigated as part of the baseline survey described above. The survey concluded that no contamination is present in the soil samples taken at the site. However, isolated points of contamination, perhaps through localised spills during construction activities may occur on site. If this contaminated soil was relocated during levelling activities, a chance of spreading the contaminants can occur, which could lead to a negative environmental impact. In addition, if contaminated soil is dispersed through dust generation as a result of construction activities like ground excavation, then further spreading of contaminants will also occur. This impact is considered of minor negative significance prior to the implementation of appropriate measures.

**Change of Drainage Regime:** Currently, the site is traversed by several Chaabas, which channel rainfall to the canyons on the boundary of the site. The proposed design of the CSP plant will require levelling and grading of the site, which would ultimately alter the drainage regime of the plateau. The result could be increased erosion of the canyon walls and siltation in the receiving water bodies. The changes will result with permanent impacts to the drainage patterns of the site, and prior to the implementation of adequate drainage

measure, the intermittent and infrequent rains are likely to result with moderate temporary impacts for erosion and siltation.

**Table 5-4 Soil, Geology and Hydrology – Magnitude of Construction Impacts**

Impact	Magnitude	Justification
Spillage	Moderate/ Minor	The volumes and quantities of hazardous materials being transported and handled during the construction phase is low, however poor handling practices will increase the likelihood of spills. Impacts could be temporary to permanent.
Inadequate waste management	Moderate/Minor	Minor volumes of hazardous wastes will be generated during the construction phase. If these wastes are not properly handled, separated, stored and then disposed, contamination is very likely to occur.
Cross contamination of soils	Minor/Negligible	During ground preparation works, levelling of the site, or disposal of soils to off site areas, there is a minor risk of cross contamination if management and monitoring mechanisms are not implemented.
Removal of natural site drainage	Moderate	The levelling of the site will result in the redirection of storm runoff water to other areas and hence change the attributes of the natural land drainage.

**Table 5-5 Soil, Geology and Hydrology – Significance of Construction Impacts**

Impact	Magnitude	Receptor	Sensitivity	Impact Significance
Spillage	Moderate	Soil	Medium	Moderate
	Minor	Groundwater	Medium	Minor
Inadequate waste management	Moderate	Soil	Medium	Moderate
	Minor	Groundwater	Medium	Minor
Cross contamination of soils	Minor	Soil	Medium	Minor
	Negligible	Groundwater	Medium	Negligible to Minor
Removal of natural site drainage	Moderate	Soil	Medium	Moderate

### 5.5.2 Mitigation Measures

As far as the construction of the proposed project is concerned, the CESMP will cover all the necessary measures to be taken prior to and during the construction phase. This will include outlining the appropriate waste storage protocols and soil and groundwater protection measures required to prevent the occurrence of spillage to the ground, and the risk of contamination. The EPC employed on site will be required to design, operate and update

the CESMP during the construction phase. This is a requirement of the Performance Standard 1 in determining an 'action plan' and management system. A key part of this document will be the soil and groundwater protection measures on the site, which will include the following measures:

- Effective management of supply chain, including selection of material suppliers which minimise packaging where possible;
- Wherever possible, reduce the quantity of chemicals and fuel stored on site to minimum practical level. Infrequently used chemicals will be ordered before they are needed;
- Store chemicals, fuels, lubricants and paints in dedicated locations such as paved, or impermeable ground surfaces to prevent leakage into the soil;
- Store hazardous liquid waste and chemicals, such as oils, etc. within containers or on impervious surfaces, over drip collectors, in order to avoid spills to the ground;
- Regularly inspect containers and impervious membranes, to prevent spills and leaks;
- Clean up any spills with specialised absorbents;
- Establish spill emergency and contingency plan;
- Mandatory training program for employees to increase their awareness of chemical management protocols including proper handling and storage of chemicals, emergency response, contingency plans and appropriate PPE.
- Contaminated aggregate wastes or excavation material shall be disposed through registered/approved waste vendor at appropriate facilities.

It is also recommended that before construction begins, each contractor should collect and test a minimum of 3 soil samples from their designated laydown areas to supplement this benchmark and to be used for verification purposes post completion of the construction activities and upon handover of the temporary laydown area. If any soil contamination is detected, then remediation of the soils should be carried out, and successful closeout of the event should be determined on the basis of the benchmark values.

In order to avoid the risk of cross-contamination, any identified contaminated soils will be excavated separately, and stored or disposed in accordance with environmentally adequate measures for waste management. Furthermore, if contaminated soils are observed during construction activities, the same protocol must be taken with separate excavation, in order to ensure that cross contamination does not take place.

- Implement a good house keeping practice during construction activities including procedures and requirements for proper handling, storage, and transport of hazardous chemicals and waste.

- Procedures for emergency response and contingency plan will be in place. A mechanism will be provided to immediately remediate the affected area in the event of a spill or leakage of chemicals, fuels, paints, and any hazardous material. A structure for emergency response and contingency plan is provided in the Environmental and Social Management Plan Volume. It is suggested that the EPC must incorporate this in their CESMP and implement throughout the site.
- The EPC, sub-contractors employed for the construction period will be required to put in place adequate training programmes, safety induction sessions with regards to the transportation and handling of hazardous materials.
- All hazardous construction waste and chemicals, such as oils, will be stored in well-equipped, leak-tight enclosures where oil drums have drip collectors to avoid spills to the ground. The storage tanks of fuels /chemicals will be properly maintained and stored in bunded area of 110% of their storage capacity.
- Washing of equipment, machineries, and vehicles should be carried out in accordance with mechanism to prevent soil and ground water contamination. Where possible, either impermeable barriers or water collection devices must be used to trap and collect the wastewater, volume of water minimized and use of cleaning solvents and chemicals limited to the minimum.
- Refuelling of trucks, lorries and vehicles will only be carried out in designated areas following specified procedures, to reduce potential spillages. A dedicated refuelling area near to the servicing area will be established. Refuelling areas will be communicated to all site personnel by signs and notice boards.
- All refueling should be carried out on concrete surfaces in order to avoid spillage of fuel;
- However, refuelling of earthmoving machinery, plant and other equipment which is not mobile and which remains in the same place for extended periods, may be refuelled on site. However, the refuelling truck must be equipped with the correct nozzle, length of pipe, adequate pump flow control, drip collectors and spill kits to prevent leaks to the soil.
- All servicing, refuelling, stockpiles, waste disposal and storage areas will be located as far as possible from the water bodies to reduce potential of pollution via spillage or windblown debris.
- Excavated materials will be kept in the stockpile for as short a time as possible.
- No hazardous material will be stockpiled.
- The size of the stockpile area should be minimized and monitored.

- The EPC will also be required to carry out dedicated risk assessment sessions to identify risks relevant to particular activities involving the use of hazardous materials and, put in place, appropriate risk reducing measures.

### 5.5.3 Residual Impacts

**Table 5-6 Soil and Hydrogeology – Residual Impacts – Construction Phase**

Impact	Magnitude	Receptor	Sensitivity	Impact Significance	Mitigation	Residual Impact Significance
Spillage	Moderate	Soil	Medium	Moderate	Yes	Minor
	Minor	Groundwater	Medium	Minor	Yes	Negligible
Inadequate waste management	Moderate	Soil	Medium	Moderate	Yes	Minor
	Minor	Groundwater	Medium	Minor	Yes	Negligible
Cross contamination of soils	Minor	Soil	Medium	Minor	Yes	Negligible
	Negligible	Groundwater	Medium	Negligible to Minor	Yes	Minor
Removal of natural site drainage	Moderate	Soil	Medium	Moderate	Yes	Minor

## 5.6 Operation Assessment

### 5.6.1 Initial Impacts

During the operational phase, potential releases to the soil and groundwater may occur from a number of routine maintenance activities, such as material transportation, handling and storage as well as during cleaning activities. However, the main risk of soil contamination at the operational phase could result from leaks at the HTF system.

HTF Leaks could occur from metal tubing, seals, flanges, other such connection points and at the following plant:

- HTF/Salts exchangers
- Expansion and overflow vessels
- HTF system pumps
- HTF line instrument connections
- Purification Flash and drainage tank
- Condensation Tanks
- Control valves

These types of leaks may occasionally occur, particularly over the lifetime operation of the plant. Typically the maintenance programme of the various facilities would ensure that such events are rare and that volumes would be minimal and quickly contained and cleaned. Therefore impacts would be temporary in nature and of minor negative significance.

The maintenance of plant and machinery at the NOORo II CSP project will involve usage of oil as a lubricant/solvents. This therefore requires appropriate storage, transportation, and handling of such oils and greases etc. These materials if not handled appropriately will have a negative impact on soil which would result with an impact of minor negative significance.

Waste oils generated following the maintenance and operation of the plant and machinery also have the potential for contamination of soil if inappropriate disposal methods are followed. Prior to mitigation, the potential impact would be of minor negative impact.

The permeability test undertaken as part of the geotechnical investigations determined an infiltration of  $Io=0.57$  cm/nm, and a permeability coefficient of  $k=7,17.10(-5)$  m/s.

### Wastewater Management

The proposed NOORo II CSP will treat process plant wastewater at an onsite facility, and subsequently all treated wastewater will be discharged to the on-site evaporation ponds. Therefore, potential for soil contamination from mishandling of wastewater or failure of the wastewater treatment system is likely. The impact and mitigations measures for this component are discussed in Chapter 6 – Water and Wastewater Management.

**Table 5-7 Soil, Geology and Hydrology – Magnitude of Operational Impacts**

Impact	Magnitude	Justification
Spills and Accidental Releases	Minor/Negligible	During maintenance or over the lifetime operation of the plant, HTF may leak to unprotected ground, and poor handling may result with spills. Groundwater table is greater than 50m.
Inadequate waste management	Minor/Negligible	Hazardous wastes will be generated during the operation of the plant, and if waste facilities are not provided nor waste management procedures implemented, then contamination could occur. Groundwater table is greater than 50m.
Cross contamination of soils	Minor/Negligible	Concrete, asphalt, bunds and superstructures will protect the majority of the surface area of the site. However, any soils that become contaminated and which are not adequately disposed may cross contaminate the receiving area. Groundwater table is greater than 50m.

**Table 5-8 Soil, Geology and Hydrology – Significance of Operational Impacts**

Impact	Magnitude	Receptor	Sensitivity	Impact Significance
Spills and accidental releases	Minor	Soil	Medium	Minor
	Negligible	Groundwater	Medium	Negligible to Minor
Inadequate waste management	Minor	Soil	Medium	Minor
	Negligible	Groundwater	Medium	Negligible to Minor
Cross contamination of soils	Minor	Soil	Medium	Minor
	Negligible	Groundwater	Medium	Negligible to Minor

### 5.6.2 Mitigation Measures

The pathways for soil contamination during the operational phase are more or less similar to the construction phase. Therefore, similar control techniques and mitigation measures will be in place to tackle such risks. Best house keeping practices will be adopted to ensure proper measures are in place.

The O&M will implement the mitigation measures listed below. Day to day measures included in the OESMP will determine the storage of hazardous chemicals as key concerns with maintenance, storage requirements, refuelling procedures and spill clean-up procedures being particular issues which will be adequately covered in the ESMP.

- The Operational Environmental and Social Management Plan that is a requirement of the IFC Performance Standards will need to ascertain the potential risks to the soil media during the operations of the plant and assign appropriate mitigation measures.
- Storage areas for hazardous material will be sealed, covered and paved with secondary containment such as bunded walls, leak tight collection reservoirs, leak tight flooring, and correct shelving / cabinets in order to prevent spillage and leakage into the ground.
- The storage tanks of fuels/HTF/chemicals will be properly maintained and stored within a bunded area of 110% of their storage capacity.
- Each bund will include a pump to empty the oil/chemical in case of an emergency.
- Fencing around the perimeter of the work area will be erected, in order to demarcate the designated work areas and limit damage to surrounding undeveloped areas.



- Plant workshops will be constructed over impervious/sealed surfaces. A drainage system with collection tank will be included to facilitate collection, storage and handling of any spills.
- The areas of the power island where the main HTF system equipment is located will be paved with reinforced impermeable concrete slabs in order to prevent any soil contamination in the event of a spill or leak. These slabs will be aligned towards specifically designed collection points. This will ensure that when HTF residues are hosed or washed away by rain, they are collected in the drainage system to be specially treated, as described in this report.
- Proper procedures, such as regular inspections, audits, and monitoring, will be put in place to ensure that all necessary mitigation measures are being implemented.
- All joints of thermal oil pipes, between pipes and also between a pipe and valves or equipment, will always be welded when possible in order to prevent leakages.
- All pipes associated with the transport of HTF will be located above ground, which will aid the identification of any damage or leaks occurring.
- All pieces of equipment will be equipped with isolation valves.
- An HTF condensation and leakage system will be installed in the thermal storage system to detect leaks, separate HTF in the circuit from salts and identify the exact source of leaks. The leakage detection system has three components:
  - Pressure measuring devices installed between the exchangers to detect possible HTF leaks due to a rapid pressure increase;
  - An analyser installed in the nitrogen compensation collector between tanks. This analyser will be able to detect the main component of HTF; diphenyl oxide; and
  - Flanged sample-taking devices for HTF leakage detection.
- HTF leak detection system will be used to detect leaks as soon as they occur, to separate the HTF present in the salt circuit, and to identify the exact location of the leak. The system will comprise of pressure gauges installed between the exchangers, analysers installed in the nitrogen collector, and sampling with flanges for the HTF leak detection.
- Twice yearly groundwater monitoring at two wells of Tasselmant will be implemented, in order to confirm no migration and pollution of the groundwater. Applicable for all three phases of the Ouarzazate SCP project.
- The site seismic conditions have to be taken into account for plant design and the ESMP's Emergency Response Plan will include procedures to be followed in case of earthquake.

### Soil Remediation strategy in the event of an HTF Leak

In the event of a leak or spill, HTF spreads out rapidly over the ground to a concentration of <2% (20 g/kg of soil), and then stabilises due to its low vaporization pressure and extreme solubility in water. Contaminated earth can be recognised by obvious staining and a characteristic odour or by the use of a portable hydrocarbon detector.

In the event of an accidental contamination a bio-remediation system will be used to treat the contaminated soils. This system of bioremediation was developed and has been tested in SEGS (Solar Electricity Generating Systems), which is located in Kramer Junction (California) and in various projects in Spain. This system will comprise of:

- Impermeable reinforced concrete tanks of approximately 470m<sup>2</sup> by 1m deep containing CO<sub>2</sub> and HO hydrocarbon degrading bacteria and capable of treating 200 m<sup>3</sup> of contaminated earth.
- The treatment process breaks up the elements of the HTF, thereby reducing the concentration of the contamination from 20 g/kg to 5 g/kg in a period of some 2 – 4 months. In order to aid the treatment, nutritional elements are added such as monopotassium phosphate and urea. Additionally, the moisture content is maintained at between 50 to 70% using a sprinkler system and the soil is superficially aerated in order to encourage bacterial activity.

### 5.6.3 Residual Impacts

**Table 5-9 Soil and Hydrogeology – Residual Impacts – Operation Phase**

Impact	Magnitude	Receptor	Sensitivity	Impact Significance	Mitigation	Residual Impact Significance
Spillage	Minor	Soil	Medium	Minor	Yes	Negligible
	Negligible	Groundwater	Medium	Negligible to Minor	Yes	Negligible
Inadequate waste management	Minor	Soil	Medium	Minor	Yes	Negligible
	Negligible	Groundwater	Medium	Negligible to Minor	Yes	Negligible
Cross contamination of soils	Minor	Soil	Medium	Minor	Yes	Negligible
	Negligible	Groundwater	Medium	Negligible to Minor	Yes	Negligible

---

## **6 WATER AND WASTEWATER MANAGEMENT**

### **6.1 Introduction**

This chapter identifies the main issues associated with water consumption and the management of the wastewater generated by the construction and operation phases of the proposed NOORo II CSP.

During both construction and operation, water from the Mansour Ed Dahbi reservoir will be piped to the project site for use in the various power producing facilities. Consequently, several wastewater streams will be generated, which will include power cycle blowdown, floor drainage in process buildings, effluents of very high conductivity and sewage. All wastewaters will be treated by onsite wastewater treatment facilities, with the resulting treated wastewater sent to onsite evaporation ponds. Therefore, no emissions of wastewater to the soils, Chaabas, Oueds or stormwater drainage system are anticipated.

The typical environmental impacts from poor wastewater management include the contamination of soils and stormwater. Both the construction and operational phases of the NOORo II CSP will generate wastewater and will have the potential to detrimentally impact upon the surrounding environment.

The recommendations and mitigation measures provided within this chapter will be utilised in the preparation of the CESMP and OESMP, to ensure that appropriate management is achieved during construction and operation.

### **6.2 Methodology**

The assessment has been conducted by identifying the relevant local and international standards and best practice relating to water and wastewater management during the construction and operational phases of the proposed facility. Estimates and figures relating to wastewater volumes and proposed treatment processes have been based on the data available from the bid proposal.

The rivers and chaabas on and around the site are ephemeral streams that flow after rain events. The erosion and flood risks posed by these streams are considered in Chapter 10 Stormwater Management and Erosion Control. This section is concerned with the project's water use and the possibilities for contamination of the water reservoir, the rivers and chaabas from the project's wastewater.

### 6.3 Baseline

The proposed source of water for this project is the Mansour Ed Dahbi reservoir. This reservoir receives water from the Oued Dades, the only perennial tributary in the area, whilst in the autumn and spring it will receive water from periodic tributaries as a result of snowmelt and increased storm activity. Under rare circumstances of extreme flood events, the reservoir will receive water from episodic tributaries.

The calculated capacity of the reservoir was estimated at 439 hm<sup>3</sup> in 2010. Contributions to the Mansour Ed Dahbi dam average 420 hm<sup>3</sup> per year (varies from 68 to 1300 hm<sup>3</sup>). The rate of filling of the dam has experienced fluctuations over the years ranging from 12% to 40% and over 90% in the last few years (97% on 04/05/2010).

The provision reserved for drinking water from the Mansour Ed Dahbi dam is 3.5 to 4 hm<sup>3</sup>/year against approximately 180 hm<sup>3</sup>/year for irrigation. Evaporation losses are estimated at about 56 hm<sup>3</sup>/year.

In years of drought, the buffered groundwater driven system of the north-eastern regions provides a reliable base for irrigation and an almost constant inflow of 50 hm<sup>3</sup> per year to the reservoir. This assures that even in years of severe drought the reservoir does not dry up.

The rivers and chaabas on and around the site are ephemeral streams that flow after rain events. There is no groundwater on the site.

### 6.4 Sensitive Receptors

The table below outlines the identified receptors in relation to wastewater as well as the determined sensitivity of those receptors.

**Table 6-1 Sensitive Receptors**

Receptor	Sensitivity	Justification
Mansour Ed Dahbi Reservoir	High	The reservoir provides water for irrigation and domestic use for the Draa region. Increasing rates of extraction and longer periods of drought will impact the reliability of water availability. Equally, any spills or discharges of contaminated water or poorly treated water may impact on the reservoirs water quality.
Soil and Groundwater	Medium	In the event of any spills or leaks of hazardous waste materials, contamination to both soil and groundwater may occur.

### 6.5 Construction Assessment

The table below provides estimates of water consumption during construction and start-up. The main uses for water during the construction and commissioning phases are domestic consumption, dust control, earthworks, civil works and commissioning. The total water

consumption for construction and commissioning is estimated to be approximately 0.43 hm<sup>3</sup> during 29 months, with an estimated monthly peak consumption of 0.034676 hm<sup>3</sup>.

**Table 6-2 Water Consumption during construction and commissioning (m<sup>3</sup>)**

Month	Man consumption	Dust control	Earth works	Civil works	Commissioning	Total
1	44	0	0	0	0	44
2	92	0	0	0	0	92
3	202	1,152	26,290	0	0	27644
4	576	1,152	26,290	0	0	28018
5	880	1,152	26,290	0	0	28322
6	1,087	1,152	26,290	0	0	28529
7	1,756	1,152	26,290	0	0	29198
8	2,059	1,152	26,290	1,750	0	31251
9	2,156	1,152	26,290	1,750	0	31348
10	2,473	1,152	0	1,750	0	5375
11	2,741	1,152	0	1,750	0	5643
12	2,908	1,152	0	1,750	0	5810
13	2,966	1,152	0	1,750	0	5868
14	3,485	1,152	0	1,750	0	6387
15	4,145	1,152	0	1,750	0	7047
16	4,585	1,152	0	1,750	0	7487
17	5,526	1,152	0	1,750	0	8428
18	6,002	1,152	0	1,750	0	8904
19	4,774	1,152	0	1,750	0	7676
20	4,668	1,152	0	0	18,450	24270
21	4,096	1,152	0	0	25,830	31078
22	4,004	1,152	0	0	29,520	34676
23	2,794	1,152	0	0	25,830	29776
24	2,728	1,152	0	0	9,840	13720
25	2,130	1,152	0	0	6,150	9432
26	1,558	1,152	0	0	3,690	6400
27	1,012	1,152	0	0	3,690	5854
28	792	1,152			0	1944
29	0	0			0	0
<b>TOTAL</b>	<b>72,239</b> <b>(0.072hm<sup>3</sup>)</b>	<b>29,952</b> <b>(0.029hm<sup>3</sup>)</b>	<b>184,030</b> <b>(0.184hm<sup>3</sup>)</b>	<b>24,500</b> <b>(0.024hm<sup>3</sup>)</b>	<b>123,000</b> <b>(0.123hm<sup>3</sup>)</b>	<b>433,721</b> <b>(0.433hm<sup>3</sup>)</b>
<b>TOTAL (%)</b>	<b>16.7%</b>	<b>6.9%</b>	<b>42.4%</b>	<b>5.6%</b>	<b>28.4%</b>	

The wastewater related to the human consumptions will be around 175 l per worker and per day, with the main source of wastewater during construction being sanitary wastewater. It's estimated that 12,5% of the human consumption is evaporated or absorbed by the body, so it does not end up in the sanitation facilities. Therefore sanitary wastewater is estimated to total 0.063209 hm<sup>3</sup> over the construction and commissioning period. This wastewater will be stored in septic tanks and tankered to the Ouarzazate wastewater treatment facility by licensed subcontractors with an acceptable frequency.

The required water for cleaning of construction equipment will generate around 0.008 m<sup>3</sup> of waste water.

Other water uses like watering temporary roads for dust prevention or earthworks will not generate wastewater, as it will be used to wet the soil and will evaporate.

Most freshwater during commissioning is used for the testing of the tanks. This water will be channelled to an evaporation pond, depending on the quality of the water. If monitoring results show that this wastewater could be treated in the water treatment plant and recycled, this option would be considered.

### **6.5.1 Initial Impacts**

The water use during construction of NOORo II CSP will be 0.4 hm<sup>3</sup> over 28 months (0.12 hm<sup>3</sup>/year). This represents 0.02% of the average contribution to the Mansour Ed Dahbi Reservoir, that is 420 hm<sup>3</sup>, and 0.17% of the lowest recorded yearly contribution to the reservoir, that was 68 hm<sup>3</sup>. This impact is considered to be of negligible significance.

The main wastewater contamination risks arising during construction relate to sanitary waste and to contaminated wastewater generated by storm water events washing oil spills.

The quantities of sanitary wastewater can be estimated at approximately 0.063209 hm<sup>3</sup> during construction and commissioning. This wastewater will be generated and stored on-site prior to removal by a licensed contractor. If the storage tanks and removal process are not properly managed and handled, contamination to soils or surface waters can take place. Prior to mitigation, this can be assessed as a moderate negative impact.

Storm water runoff can wash areas containing hazardous materials and either infiltrate into the soil or carry them off site, potentially contaminating watercourses or groundwater. This potential impact can be assessed as being a moderate negative impact prior to implementation of wastewater and soil (chapter 5) mitigation measures.

The quantity of water that will be used during testing is a little over a quarter of the total volume of water used during the construction/commissioning stage. Given that the total water consumption represents less than 1% of the average contribution, the impact from testing is negligible.



**Table 6-3 Water and Wastewater – Magnitude of Construction Impacts**

Impact	Magnitude	Justification
Sanitary Wastewater	Moderate	Such impacts may result in a moderate but temporary impact to soil and groundwater due to potentially high levels of nutrients and pathogens.
Construction water	Negligible	The relative quantity of water needed during construction is a negligible fraction of the total input to the dam.
Stormwater	Moderate	Although infrequent, the result of storm water runoff may contaminate the soils and groundwater

**Table 6-4 Water and Wastewater – Significance of Construction Impacts**

Impact	Magnitude	Receptor	Sensitivity	Impact Significance
Sanitary Wastewater	Moderate	Soil and Groundwater	Medium	Moderate
Construction water	Negligible	Mansour Ed Dahbi Reservoir	High	Minor
Stormwater	Moderate	Soil and Groundwater	Medium	Moderate
		Mansour Ed Dahbi Reservoir	High	Moderate to Major

### 6.5.2 Mitigation Measures

During construction, the following mitigation measures shall be taken:

- Chemical toilets will be available on site and septic tanks will be installed at the labour accommodation and administration buildings. The number of septic tanks will be proportional to the increased of workers on site. These will also be regularly emptied by a licensed waste contractor and transported to an approved sanitary waste facility off site. The EPC contractor will keep records of the disposal events in order to give an indication of required frequency of removal and for auditing purposes. If possible, meters will be installed on the tanks to monitor the volumes and prevent overflows. The septic tanks will be above ground where possible, though if buried, will be placed in secure areas, away from general vehicle traffic, in order to prevent any damage to the tanks.
- The EPC contractor will develop procedures for the demobilisation of the septic tanks once site construction has ended to ensure that appropriate procedures/methods will be employed and no contamination to the site area will occur during the demobilisation period.
- A package STP may be installed on site if a suitable sized system can be located in country. The treated water may be used for dust control, if the testing results comply with Moroccan standards for re-use.

- Site inspections will be carried out regularly by the EPC contractor to ensure that all wastewater generated is properly managed, and no leakages or spillovers occur. In the event of a spill or overflow, immediate action will be taken in accordance with spill containment procedures.
- Construction of a specific area for site machinery maintenance (lubrication, oil and filter changes, repair work, etc.). A waterproof concrete area or impermeable geotextile liner shall be provided with a tank or perimeter ditch to collect any liquid waste.
- Oily wastewater from vehicle maintenance will be collected via interceptors. A specialist contractor will remove the recovered oil for recycling. Any residual sludge will be taken to a licensed hazardous waste facility.
- Storage of wastewater in areas adjacent to the Oueds, Chaabas and drainage ditches shall be avoided. Any such storage under specific circumstance permitted by the Environmental manager will be only temporary measures.
- Where suspended solids wastewater are above normal levels, specific measures shall be taken: settling basins, drainage ditches, filtering geotextiles
- Construction of a settling basin to retain water until it is clear. Wastewater from the cleaning of concrete trucks that could include cement and concrete waste shall be directed to this basin. Water free of sediments may be used to irrigate the site area and access routes.
- The basins must be monitored to establish the regularity of sludge drainage.
- The quality of the effluent shall be regularly controlled and all necessary maintenance work shall be performed, including the regular removal of sludge.
- Treated effluents that cannot be re-used on site, must be taken to the authorised disposal point without the entrainment of soil, material or any other substance that could contaminate them.
- On all accounts, the spillage and runoff of oils, greases and other toxic liquid waste from the machinery fleet outside this waterproofed area will be avoided.
- The machinery to be used in the work shall be inspected regularly to avoid losses of lubricants and fuel.
- The storage of waste generated on site shall be located outside areas in which runoff could affect nearby watercourses and preferably within the area used by the machinery fleet.
- Following the IFC EHS Guidelines, effort will be made in training employees including all sub-contractors at the site to minimise water consumption and ensure an understanding of wastewater issues.

- Once the work is complete, all wastewater storage equipment and containment systems must be duly dismantled. The dismantling shall include the final drainage of any existing water and sludge, removal of the waterproofing liner, filling of the excavated pit and any other activities required to ensure that the land is re-instated to its initial state. All excess products must be taken to the landfill site.
- Measures to minimise water use during commissioning, such as recycling shall be implemented by the contractor. These include re-use of the hydrotesting water, until this phase of testing is completed and the water is no longer serviceable. Subsequently, the wastewater will be sent to the evaporation ponds.

### 6.5.3 Residual Impacts

Following the implementation of measures prevent discharge of wastewaters, to re-use treated wastewater, and to minimise overall water consumption; the majority of the impacts will be decreased.

**Table 6-5 Wastewater – Residual Impacts – Construction Phase**

Impact	Magnitude	Receptor	Sensitivity	Impact Significance	Mitigation	Residual Impact Significance
Sanitary Wastewater	Moderate	Soil and Groundwater	Medium	Moderate	Yes	Minor
Construction water	Negligible	Mansour Ed Dahbi Reservoir	High	Minor	Yes	Negligible
Stormwater	Moderate	Soil and Groundwater	Medium	Moderate	Yes	Minor
		Mansour Ed Dahbi Reservoir	High	Moderate to Major	Yes	Moderate

## 6.6 Operation Assessment

### Operation Water Consumption and Wastewater Generation and Treatment

The NOORo II CSP will draw all its water from the Mansoor Al Dhabbi Reservoir, via the common water storage tanks managed by MASEN for the three NOORo plants. The raw water will be used within the plant facilities at various stages of the power production process, as well as for domestic purposes. In order to ensure that the water meets the specifications of the various facilities, the raw water will go through a series of treatment processes at the NOORo II CSP. The water consumption in the Plant and the amount of waste generated depends directly on the electrical production, which varies during the year according to the solar radiation. The following table and diagram provides the breakdown

of the raw treatment and consumption process at the various stages of the water cycle within the NOORo II CSP, at peak water demand.

### Water Consumption and Management

The peak water requirements for the operational phase of the plant are estimated to be 41.55m<sup>3</sup>/h, and will be used in accordance in the following estimates:

SERVICE	ESTIMATED FLOW (m <sup>3</sup> /h)
Total Potable water supply	0.30
Demineralised water for mirror cleaning	12.02
Demineralised water for miscellaneous consumers	6.04
Demineralised water for Steam Generator	24.96
Raw water for cleaning (Non oily Drains)	2.00

The following diagram is a simplification of the raw water usage at the NOORo II CSP.

**Plate 6-1 Water Use Diagram**

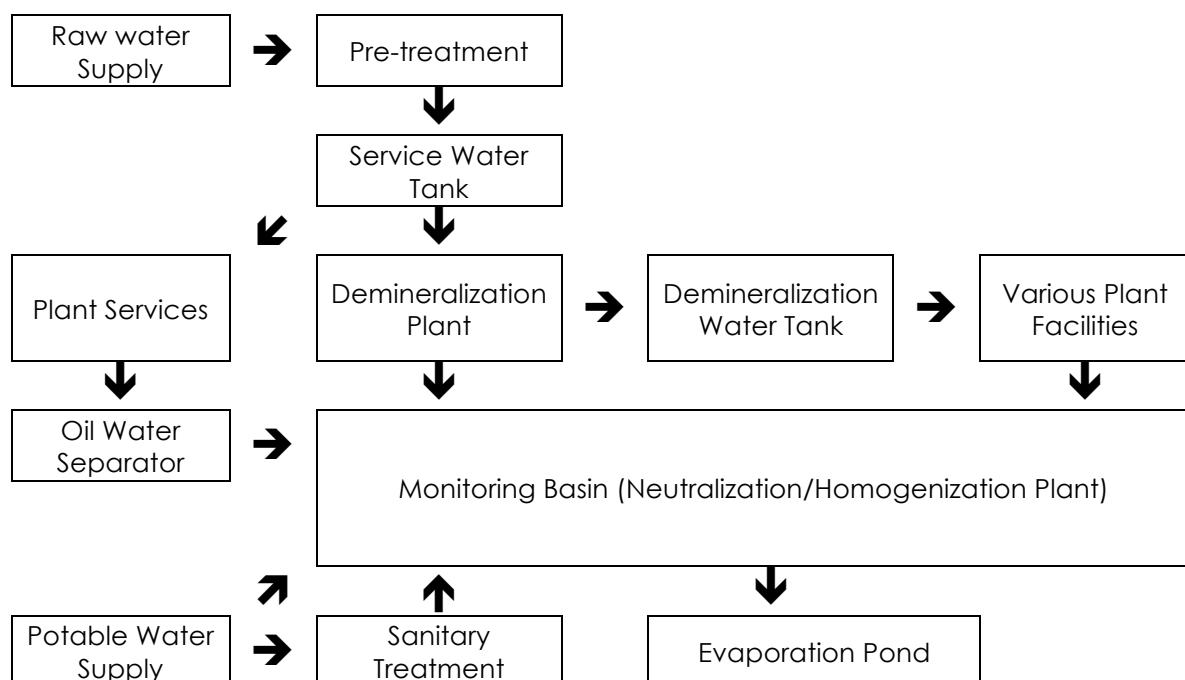

The following diagram details the quantities of raw water that is treated, used and discharged by the NOORo II CSP.

Plate 6-2 Raw Water Process Cycle at NOORo II CSP (Unit m<sup>3</sup>/h)

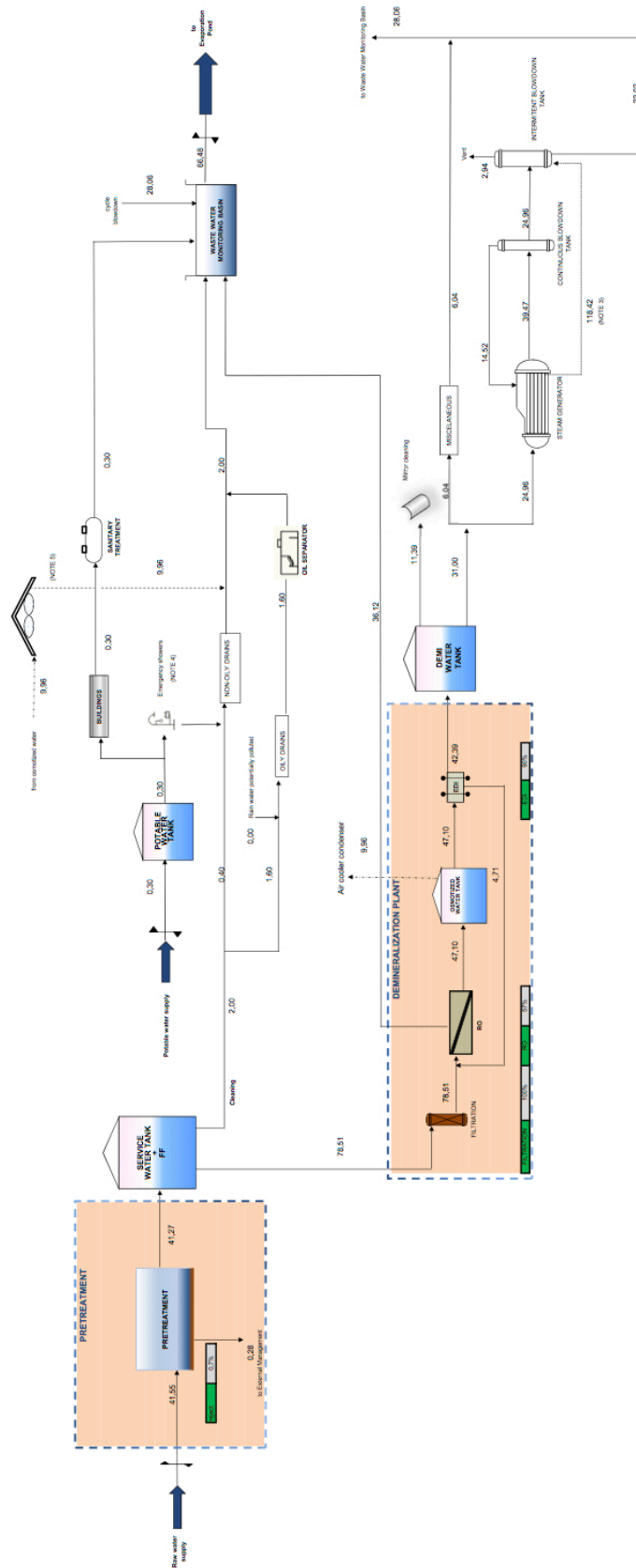

The following units constitute the water treatment plant that will be used onsite to meet the project's water needs:

**The pre-treatment unit:**

Includes a disinfection system with hypochlorite, coagulation-flocculation, floatation and solids removing system by means of anthracite-sand filters.

The treatment process will comprise of a chemical conditioning system, microfiltration, and reverse osmosis. The concentrated liquid resulting from this first step of osmosis will be treated again to minimize the final water flow to be poured in the evaporation ponds. The first step of reverse osmosis will also treat the water that will be further processed to obtain demineralized water.

**Demineralized water unit:**

The water treated in the previous osmosis process will be fed into a polishing system which will consist of chemical conditioning system, microfiltration, a second step of the reverse osmosis and an electro deionization stage.

**Wastewater Generation and Treatment**

All liquid effluents produced in the CSP plant are collected in a separate network for either re-use or neutralisation before being sent to the evaporation ponds. The design and operation of the plant has ensured that re-use of water is optimised so that the number and size of evaporation ponds can be minimised. The following wastewaters will be generated in the plant.

**Table 6-6 Estimate Peak Wastewater Production (m<sup>3</sup>/h)**

Wastewater Stream	Estimated Peak Production
From WSAC blowdown	3.2
From WSAC tank excess	45.4
To monitoring basin	55.9
From pretreatment reject	0.3
From draining system	2.00
From WSAC blowdown	3.2

The BOP drainage system will collect the different wastewater streams produced during the plant operation and send them to specific treatment processes depending on the effluent's nature followed by final discharge to the evaporation ponds.

The drainage network will be designed to allow the separation of the effluents with the aim of applying the most appropriate treatment to each one, it will therefore comprise of the following:



- Collection systems
- Retaining bunds at sump outlet
- Light Hydrocarbons Separator from the Power Island
- Hydrocarbons Separator from HTF and Salts area
- Neutralization and Homogenization basin
- Discharge network to the evaporation pond

The way in which each of the above wastewater streams will be treated is discussed below:

### **Sludge treatment**

The sludge generated in the floatation equipment by dissolved air will be piped to a static thickener. The clarified of the thickener will be returned for physical-chemical pre-treatment, while the thickened sludge will be directed to a centrifugal decanter. The clarified of the centrifuge will be pumped to the floatation chamber of the pre-treatment.

In order to estimate the quantity of solid waste to be managed after dehydration, the suspended solids content in raw water and the different efficiencies of the pre-treatment equipment have been considered. The estimated quantity of waste from water treatment is about 3,500 kg wet sludge/h. The management of this solid waste is discussed in Chapter 9.

### **Closed Cooling purge treatment**

The purge of the cooling circuit will be fed to a chemical conditioning system and a first step of reverse osmosis.

The concentrate from the first reverse osmosis will be treated by a second reverse osmosis system in order to minimize the flow to the evaporation ponds. The permeate from this second reverse osmosis will also be pumped to the Cooling system; while the concentrate will be channelled to the evaporation ponds.

### **Treatment of oily water and water with HTF**

The water from the oily water storm tank will be channelled to an oily water treatment system, and the water from the HTF water storm tank will be channelled to the HTF separator.

In both separators the effluent enters into a first feeding chamber, where the separation of the large solids drops starts, and passes to a second chamber through a coalescent plate's package where the smaller solids are separated.

The sludge, oils and HTF will be removed and stored for later management, as discussed in Chapter 9. The estimated quantities of sludge, oils and HTF are specified below:

- Sludge from oily water separator: 120 kg wet sludge/h;
- Oils from oily water separator: 5 kg oils/h;

- Sludge from HTF separator: 160 kg wet sludge/h;
- HTF from HTF separator: 7 kg HTF/h.

Treated water will be sent to the effluent treatment plant, where it will join with the rest of the effluents and channelled to the evaporation ponds.

### **Sanitary water treatment**

In order to estimate the sanitary water total flow to be treated, the following data have been considered as design basis:

- Number of workers: 50 people
- Generation rate: 120 L/(person ·day)

An average of 6 m<sup>3</sup>/d of sanitary water is expected, which will create an average estimated quantity of sludge from sanitary treatment of 5 kg wet/h.

The sanitary waste water will be treated in a module of biological treatment prior to discharge to the homogenization/neutralization basin.

The biological treatment is made up of a ventilation tank and primary decantation tank. It is designed to work according to the principle of activated sludge by prolonged aeration, using a horizontal cylindrical tank made of two chambers.

The composition of the sanitary water treatment sludge will include suspended solids, organic material, iron, aluminium and silica.

### **Boiler blow down**

The flow from the auxiliary steam boiler blow down will be channelled, together with the treated oily waters and the treated sanitary waters, towards the homogenization / neutralization pit of the Effluents Plant, where these discharges will be neutralized before being driven jointly to the evaporation ponds.

### **Concentrates of reverse osmosis**

The concentrate of the reverse osmosis, together with the rejection generated in the purge treatment, will be channelled to the evaporation ponds.

### **Evaporation ponds**

The estimated total wastewater flow to be discharged to the evaporation ponds is 55.9m<sup>3</sup>/h. The following parameters are expected in the effluent:

- pH: 7.6
- Conductivity: 5,200 uS/cm
- TDS: 3,500 ppm

- SS: 25 ppm

Two evaporation ponds have been designed to collect the effluent from the plant. They will be located to the south of the site. The evaporation area of each of the ponds is provided on the table below. The ponds will have a depth of 1 m. The ponds will be allowed to fill to a depth of 0.5 m, with a reserve of 0.5 m to the crown on the least favourable side.

**Table 6-7 Evaporation Pond Areas**

Pond No.	Area (m <sup>2</sup> )
1	35,650
2	35,650
<b>Total</b>	<b>71,300</b>

The ponds will not be filled from any other sources than those generated in the plant and outlined above and from any direct rainfall over their surface area.

The impermeability of the ponds is accomplished through a 1.5 mm thick high-density polyethylene (HDPE) geo-membrane sheet. This sheet will be laid over a geo-drain made from a 250 g/m<sup>2</sup> non-woven geo-textile sheet. Deep drainage will be located under the ponds connected with a perforated pipe, so that any leaks could be promptly detected.

Other water uses on site do not generate wastewater streams. Demineralised water used to clean the dust that is naturally deposited on the parabolic mirrors will evaporate without creating significant runoff.

### **Wastewater streams Monitoring**

Continuous monitoring equipment will be installed at the discharge point to the Neutralization and Homogenisation basin, for analysis in accordance with the National discharge requirements.

- Continuous: pH, Temperature, conductivity, and flow rate.
- Bi-weekly basis: BOD/COD, Oils, TSS, Nitrogen, Phosphorous, and Total coliform bacteria.
- Every three months; heavy metals.

#### **6.6.1 Initial Impacts**

This SESIA has only evaluated the water consumption for NOORo II CSP. The projected volume of water required from the Mansour Ed Dhabbi Reservoir for the full 500MW Ourazazate solar power complex calculated by MASEN and assessed in the FESIA was approximately 6hm<sup>3</sup> of water. Approval was granted to MASEN for the full consumption for 50 years, by l'Agence du Bassin Hydraulique de Souss Massa et Draa (ABHSMD). (Approval letter title: « Concession accordée a MASEN relative a l'utilisation des eaux de la retenue du

barrage Mansour Ed Dahbi pour la réalisation et l'exploitation du complex solaire situe dans la Province d'Ouarzazate » 2nd November 2012). However it should be noted that a key benefit from using dry cooling technology for the Phases 2 and 3 of the NOORo complex, is that the 50year water consumption estimate is now greatly reduced..

Annual natural inflows to the Mansour Ed Dahbi reservoir average 420 hm<sup>3</sup>. The water use during the operation of NOORo II CSP will be 0.36 hm<sup>3</sup>. This represents 0.08% of the average yearly natural inflow to the Mansour Ed Dahbi Reservoir, and 0.52% of the lowest recorded yearly natural inflow to the reservoir, that was 68 hm<sup>3</sup>.

The quantity of water used for drinking water supply from the reservoir is 3.5 to 4 hm<sup>3</sup>/year. According to the FESIA, approximately 180 million m<sup>3</sup> per year are used for irrigation. Therefore, the 0.36 hm<sup>3</sup> that will be used for the plant are insignificant compared to the water used for irrigation and will be a negligible contributor to the cumulative impact on the reservoir. This impact is considered to be of negligible to minor negative significance.

The NOORo II CSP will generate several wastewater streams that could have a potential impact on the environment. These include the power cycle blow down, floor drainage in process buildings, effluents of very high conductivity, the reject from reverse osmosis treatment at the water treatment plant and a relatively small amount of sewage from the workforce. These wastewaters, if improperly treated could result in an impact of moderate negative significance.

**Table 6-8 Water and Wastewater - Magnitude of Occupation Impacts**

Impact	Magnitude	Justification
Raw Water Consumption	Negligible to Minor	The CSP Plant will use dry cooling technology, which greatly reduces the need for water in the plant process
Plant Wastewater	Moderate	Significant volume of brine will be generated, however following mixing with other wastewater streams the salinity will be significantly reduced.
Domestic Wastewater	Minor	Minor volume will be generated and will be tinkered off site.

**Table 6-9 Water and Wastewater - Significance of Occupation Impacts**

	<b>Magnitude</b>	<b>Receptor</b>	<b>Sensitivity</b>	<b>Impact Significance</b>
Raw Water Consumption	Negligible to Minor	Mansour Ed Dahbi Reservoir	High	Minor
Plant Wastewater	Moderate	Soil and Groundwater	Medium	Moderate
Domestic Wastewater	Minor	Soil and Groundwater	Medium	Moderate

### 6.6.2 Mitigation Measures

Several mitigation measures have been included in the design of the NOORo II CSP to reduce water use and treat wastewater streams following BAT. As a result of this design, several loops have been designed in the plant water cycle to reuse water and all the wastewater streams are appropriately treated before they are discharged into the evaporation ponds, resulting in zero wastewater discharges.

In addition, provisions have been made for wastewater monitoring, to ensure that all the measures function adequately.

Other mitigation measures that will be implemented include:

- In common with the IFC EHS Guidelines, effort will be made in training employees including all sub-contractors at the site to minimise water consumption and ensure an understanding of wastewater issues.
- Mechanisms and management practices to further reduce the volume of water required in the plant (e.g. increased reuse rates of treated effluent) will be considered, as this would help decrease freshwater consumptions.
- Routine testing of the effluents will verify compliance with the technical specifications, national legislation and IFC requirements.
- Routine testing on drinking water to ensure compliance with the national standards.
- Routine inspection for any leaks at the drainage wells located under the evaporation.
- All above ground tanks and basins will have overflow pipes to an effluent collection point.
- The time that it takes for rainwater to wash off the surfaces where there is a risk of HTF and oil spills will be monitored to ensure that 10 minutes is sufficient to collect all the potentially polluted wastewater.

### 6.6.3 Residual Impacts

The level of water consumption during operation are low compared to the yearly contributions to the Mansour Ed Dahbi Reservoir. Several loops in the wastewater treatment have been designed to reuse as much water as possible.

Due to water treatment and reuse and the use of evaporation ponds, there will be zero wastewater discharges from the plant.

Therefore, following the implementation of the mitigation measures detailed above it is expected that the residual impacts may be decreased.

**Table 6-10 Water and Wastewater– Residual Impacts – Occupation Phase**

Impact	Magnitude	Receptor	Sensitivity	Impact Significance	Mitigation	Residual Impact Significance
Raw Water Consumption	Negligible to Minor	Mansour Ed Dahbi Reservoir	High	Minor	Yes	Negligible
Plant Wastewater	Moderate	Soil and Groundwater	Medium	Moderate	Yes	Minor
Domestic Wastewater	Minor	Soil and Groundwater	Medium	Moderate	Yes	Minor

## 7 AIR QUALITY

### 7.1 Introduction

This chapter describes the potential impacts and effects that may occur as a result of the proposed construction and operation of the solar power plant, and identifies the measures that will be implemented, in order to mitigate these impacts. The assessment of impacts has been measured against national Moroccan standards and applicable WB/ IFC standards and guidelines.

It will be noted that impacts to the air at the operational phase will be significantly reduced and will consist mainly of potential fugitive emissions of VOCs from the Heated Transfer Fluid (HTF). All other typical air pollutants, such as NO<sub>x</sub> and, SO<sub>x</sub> will be emitted only infrequently, when the boiler is operated. However, to ensure a comprehensive air quality assessment, the key pollutants that have been monitored and assessed include: oxides of Nitrogen (NO<sub>x</sub> as NO<sub>2</sub>), Sulphur dioxide (SO<sub>2</sub>), Particulates (PM) and Volatile Organic Compounds (VOC).



## 7.2 Methodology

Baseline information regarding the existing air quality at the site has been compiled through a combination of primary and secondary data, gathered via field studies and a review of previous studies undertaken in the surrounding area.

Ambient Air Quality Monitoring was undertaken on February 27<sup>th</sup> for 72hours at two locations each, using a continuous high volume mass sampler for NO<sub>2</sub>, SO<sub>2</sub>, O<sub>3</sub> and PM<sub>10</sub>. Equipment to continuously monitor wind speed, wind direction, humidity, and temperature was also installed for the monitoring period.

Monitoring of these parameters was conducted at two separate locations specifically chosen to provide representative air quality characteristics of the un-influenced free-field site and at the closest sensitive receptor for air quality. Therefore, Site N2A1 was located between the boundaries of NOORo II and NOORo III; and Site N3A1 was located at the southern end of the Village of Tasselmant.

The purpose of the monitoring campaign was to establish a benchmark for the parameters that will be emitted during the operational phase of the proposed CSP Plant, and will therefore be used for evaluation purposes and compliance verification during the monitoring phase. The results and discussion are provided in the next section. Additionally, the assessment of impacts from the construction and operation phase can be adequately based on the information gathered during the site visits and summarised from the secondary studies relating to transportation, socio-economy, land-use and ecology.

**Table 7-1 Monitoring Coordinates**

Site Reference	North	West
N2 A1	31° 2'53.58"N	6°52'11.03"W
N3 A1	31° 5'9.26"N	6°51'17.96"W

## Plate 7-1 Monitoring Locations

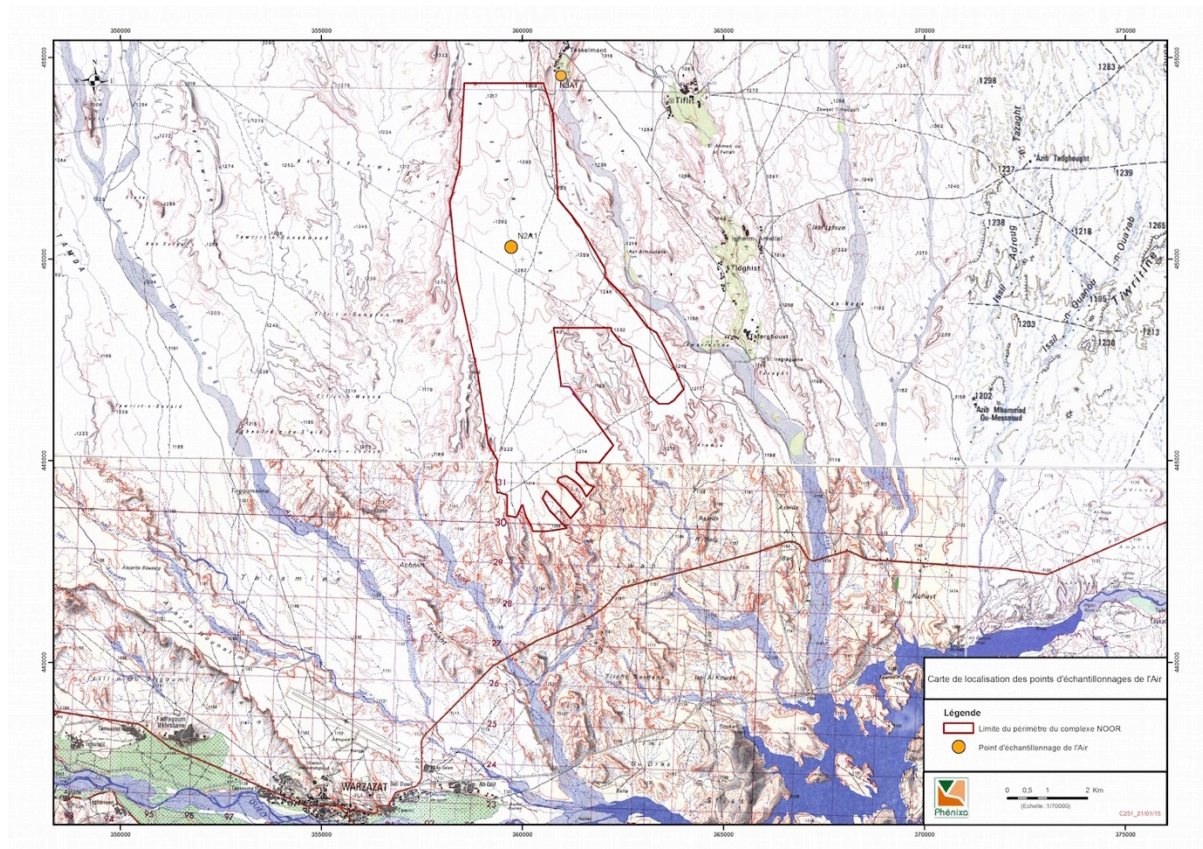

### 7.3 Baseline

The proposed NOORo II CSP will be built in a relatively isolated area. The closest large town, Ouarzazate, is over 10Km from the site and only two roads, RN 10 and RP 1511, currently pass adjacent to the project. Long-term traffic on these roads is limited to light commercial and private transport, with few heavy vehicles being used for small construction projects, such as houses or small/low-rise buildings. Recently, heavy vehicle traffic has increased due to the construction of the NOORo 1 CSP, however, this is considered a short term impact, and the frequency of vehicle use will decrease as the quantities of major equipment and building materials decreases.

No heavy industries are found as far as 75Km upwind from the site, this is due to the topography of the Atlas Mountains range. Equally, further north in the Province of Marrakesh, no heavily polluting industries are found. The main commercial activities in the area are agro-industries (processing of fruit and vegetables, wool, flour), building materials, leather goods production and carpet production.

As a result, point source and non-point source emissions around the proposed project area are insignificant and any impacts to the ambient air quality are considered negligible.

## Analytical Results

**Table 7-2 Ambient Air Quality Monitoring Results for N2A1**

Max Limit	NO2	SO2	O3	PM10
	ug/m3	ug/m3	ug/m3	ug/m3
	Detection Limit			
	200	20	100	50
<b>Date</b>				
10/02/2015	21.1	1.5	10.8	11.3
11/02/2015	20.7	2.0	12.1	10.9
12/02/2015	20.8	1.7	11.1	10.3

**Table 7-3 Ambient Air Quality Monitoring Results for N3A1**

Max Limit	NO2	SO2	O3	PM10
	ug/m3	ug/m3	ug/m3	ug/m3
	Detection Limit			
	200	20	100	50
<b>Date</b>				
10/02/2015	19.2	1.1	12.2	9.2
11/02/2015	23.1	1.2	13.4	9.1
12/02/2015	19.4	1.3	12.8	9.7

### Ambient Air Quality Monitoring Results

Overall the monitoring values observed for NO<sub>2</sub>, SO<sub>2</sub>, O<sub>3</sub> and PM<sub>10</sub>, show that the ambient air quality conditions within and adjacent to the NOOR0 III proposed Solar Power Complex, are well within the national ambient air quality guidelines, and considered good.

It should be noted that the measured value of NO<sub>2</sub> ranged between 19.2 and 23.1 µg/m<sup>3</sup>, in the town of Tasselmant, which is a reflection of the use of vehicles passing through the town. Equally, at the monitoring location adjacent to the project, the average concentration was 20.87µg/m<sup>3</sup> which is a reflection of traffic generated by the road and construction traffic.

## 7.4 Sensitive Receptors

**Table 7-4 Air Quality - Receptors sensitivity**

Receptor	Sensitivity	Justification
Air Quality (Gaseous and Particulate)	Low	The existing air shed is non degraded and background levels for all regulated pollutants are well below the Moroccan and WHO Ambient Maximum Allowable concentrations.
Tasselmant Village	Medium	Small village with a population numbering under 100, farming activities do not generate air emissions, although occasional dust when tilling the land.
Power plant employees	Low	The site is classified as industrial, consequently the workers' vulnerability is considered low.

## 7.5 Construction Assessment

### 7.5.1 Initial Impacts

During construction, the ambient air quality at local receptor sites may potentially be affected by increased dust, particularly during the earthworks phase and by gaseous exhaust fumes from construction vehicles, plant and additional vehicle movements to and from the site.

The principle sources of dust and emissions during construction will be:

- Excavation and earthwork, such as ground breaking, cutting and levelling;
- Truck movement over unpaved surfaces;
- Movement of vehicles to and from the site (e.g. for deliveries);
- Dust from uncovered truckloads;
- Emissions (e.g. NO<sub>x</sub>, SO<sub>x</sub> and CO) and particulates from vehicles, generators, heavy plant and other mechanical equipment; and
- Stored VOCs and other volatile hazardous materials.

As outlined in Section 3.4 there are few sensitive receptors within close proximity to the site. This includes the village of Tasselmant 5.6Km north of the site and the city of Ouarzazate 12-16 Km south of the site. However, due to their location and distance from the site there is little potential to be impacted by the above emissions sources during the construction phase.

The following table summarises the predicted impact levels from the various sources on the nearest sensitive receptors.

**Table 7-5 Air Quality – Magnitude of construction impacts**

Impact	Magnitude	Justification
Dust from Earthworks	Minor to Moderate negative	Temporary but reversible effects and cumulative loss of air quality in the site and immediate surroundings due to dust dispersion outside project boundary.
Dust from Vehicles	Minor negative	Temporary and reversible impacts are anticipated; and the number of vehicles is expected to be low. The majority of the transport roads will be paved.
Gaseous and Particulate emissions from Vehicles	Moderate negative	Noticeable temporary impacts are likely to occur at the site itself, throughout the construction phase. Where vehicles are combined with existing traffic flows the addition of emissions is likely to be minimal.
VOCs and other hazardous volatiles	Minor to moderate negative	Noticeable temporary impacts are anticipated, but these will be limited to the site.

**Table 7-6 Air Quality - Significance of Construction Impacts**

Impact	Magnitude	Receptor	Sensitivity	Impact Significance
Dust from Earthworks	Minor to Moderate negative	Air Quality (Particulates)	Low	Negligible to Minor
		Tasselmant Village	Medium	Minor
		Power plant employees	Low	Negligible to Minor
Dust from Vehicles	Minor Negative	Air Quality (Particulates)	Low	Negligible to Minor
		Tasselmant Village	Medium	Minor
		Power plant employees	Low	Negligible to Minor
Air Emissions from Vehicles	Moderate negative	Air Quality (Gaseous)	Low	Negligible to Minor
		Tasselmant Village	Medium	Minor
		Power plant employees	Low	Negligible to Minor
VOCs and other hazardous volatiles	Minor to moderate negative	Air Quality (Gaseous)	Low	Negligible to Minor

### 7.5.2 Mitigation Measures

The EPC contracted to deliver the works will be responsible for the preparation and implementation of a detailed Construction Environmental and Social Management Plan, in accordance with the requirements included within the Environmental and Social



Management and Monitoring section of this SESIA. This will include a detailed list of the potential environmental aspects associated with the construction process. The air mitigation measures will be followed by contractors on site and will include at least the following:

- Access roads from the entrance to the site will be compacted and sprayed with water to minimise the dust generated from the vehicles and trucks.
- Recycled water from vehicle washing and cement factory may be used in order to minimize the demand on potable water from the dam;.
- Deliveries of equipment/plant to the site will be efficiently managed to reduce the number of trips.
- Large sand piles will be avoided where possible. Otherwise wind barriers, or covers for small piles will be utilized, particularly during periods where the wind speed exceeds 15km/h.
- A visual assessment of dust emissions (visual monitoring) will be undertaken on a regular basis.
- Designated roads will be made clear to the drivers and signs for the directions and speed limit will be placed all along the roads.
- Where sand and other dusty material (e.g. cement) is transported to the site, trucks will not be overloaded and will be appropriately covered / sheeted to eliminate the contamination to the air.
- Sand and other materials will be stored in specific designated areas and will be properly stored on site so as to be protected from wind.
- Exhaust fumes and particulates emitted from trucks and vehicles will be minimised by assuring the use of good condition vehicles and conducting regular maintenance. The vehicles will be tested to ensure compliance with local standards.
- Periodic ambient air quality monitoring (NO<sub>x</sub> & SO<sub>x</sub>) will be undertaken at the identified sensitive receptors, in order verify that national ambient air quality MALs are not exceeded.
- Routine monitoring of the dust levels and wind conditions at the site will be conducted, in order to verify that on site operational activities are not contributing to any potential increases in dust levels.
- Vehicles and plant will be turned off while waiting on site to minimise gas emissions. This can be achieved by providing air-conditioned shelters for drivers especially when loading/unloading.
- Dusty materials stockpiles and dusty activities such as stone cutting and grinding will be sited away from the site boundaries and/or effectively screened.
- Fires and material burning is not allowed on the Project site.



- Hazardous materials stored and used on site with potential gas emissions (e.g. VOCs) will be located in well ventilated secure areas away from major transport routes.
- Any on-site staff accommodation will have adequate sanitary waste and domestic waste facilities and collection in order to minimize odour issues and reduce the potential for spillages and ground/water contamination.

### 7.5.3 Residual Impacts

Following the implementation of an appropriate CESMP (which will at least include the mitigation measures outlined above, and others as noted within the Environmental and Social Management and Monitoring section) the overall residual effects are expected to be of a temporary/short-term duration and of minor negative significance.

**Table 7-7 Air Quality – Residual Impacts – Construction Phase**

Impact	Magnitude	Receptor	Sensitivity	Impact Significance	Mitigation	Residual Impact Significance
Dust from Earthworks	Minor to Moderate negative	Air Quality (Particulates)	Low	Negligible to Minor	Yes	Minor
		Tasselmant Village	Medium	Minor	Yes	Minor
		Power plant employees	Low	Negligible to Minor	Yes	Minor
Dust from Vehicles	Minor Negative	Air Quality (Particulates)	Low	Negligible to Minor	Yes	Minor
		Tasselmant Village	Medium	Minor	Yes	Minor
		Power plant employees	Low	Negligible to Minor	Yes	Minor
Air Emissions from Vehicles	Moderate negative	Air Quality (Gaseous)	Low	Negligible to Minor	Yes	Minor
		Tasselmant Village	Medium	Minor	Yes	Minor
		Power plant employees	Low	Negligible to Minor	Yes	Minor
VOCs and other hazardous volatiles Dust from Earthworks	Minor to moderate negative Minor to Moderate negative	Air Quality (Gaseous)	Low	Negligible to Minor	Yes	Minor
		Air Quality (Particulates)	Low	Negligible to Minor	Yes	Minor
		Tasselmant Village	Medium	Minor	Yes	Minor

## 7.6 Operation Assessment

Generally, solar power plants by their very nature are low emitters of air pollutants. The objective of the facility is to use renewable and clean fuel to generate power. The clean fuel in this type of operation is solar heat that is magnified by the mirrors, trapped by an oil which is then converted into thermal energy within a boiler to produce steam for a conventional steam turbine. In fact, the solar power plant will have a net positive impact on the regional air quality, as it will prevent approximately one million tonnes of CO<sub>2</sub> per year from being emitted, if a conventional fossil fuel power plant had been used (according to the MEMEE estimates). Therefore, the solar plant is helping to offset negative impacts from CO<sub>2</sub> emissions and the effects of Global Warming.

Nevertheless, this solar plant is not a zero emission facility, and point source and non point source emissions will occur, albeit in limited quantities and intermittently.

### Boilers

The Project will have back up heating to maintain the heat/conversion system when solar heating isn't available, to keep the salt for storing heat in a liquid state, and to keep the HTF warm. As such air emissions from the boilers will meet the appropriate WBG EHS Guidelines for thermal power generation. As the boilers will be used primarily for standby heat, they are likely to run less than 500 hours per year, the threshold for the application of the WBG air emission guidelines. The Project will nonetheless monitor the hours of operation and the air emissions of the boiler.

These boilers will be the primary source of green house gases (GHG) for the Project. Equator Principles 2 and 10 require the analysis of alternative and annual reporting of GHG emissions, if a project is expected to emit more than 100,000 tonnes of CO<sub>2</sub> per annum. Given that the CSP will not produce such a quantity of CO<sub>2</sub>, the requirement for reporting is not applicable.

Two auxiliary boilers of 36MWt will be run on low sulphur diesel. The following table provides the emission estimates from these boilers.

**Table 7-8 Auxiliary Boiler Exhaust Gases**

Pollutant	Emission Rate (g/s)	Chimney Height (m)	Chimney Diameter (m)	T (°C)	Exit Velocity (m/s)
CO	0,0944 g/s (100 mg/m <sup>3</sup> )	15 m	0.40 m	175 °C	7,5 m/s (3400 m <sup>3</sup> /h)
NO <sub>x</sub>	0,1889 g/s (200 mg/m <sup>3</sup> )				
SO <sub>2</sub>	0,0944 g/s (100 mg/m <sup>3</sup> )				
PM10	0,0472 g/s (50 mg/m <sup>3</sup> )				

**Table 7-9 HTF Boiler Exhaust Gases**

Pollutant	Emission Rate (g/s)	Chimney Height (m)	Chimney Diameter (m)	T (°C)	Exit Velocity (m/s)
CO	0.5089 g/s (100 mg/m <sup>3</sup> )	22 m	1 m	230 °C	8 m/s (18000 m <sup>3</sup> /h)
NO <sub>x</sub>	1.0179 g/s (200 mg/m <sup>3</sup> )				
SO <sub>2</sub>	0.5089 g/s (100 mg/m <sup>3</sup> )				
PM <sub>10</sub>	0.2544 g/s (50 mg/m <sup>3</sup> )				

### HTF Venting Emissions

Although the HTF has a high thermal stability, over time the oil will degrade and volatile compounds, known-as 'low boilers' will be generated, which will need periodic elimination. This process is handled in the Ullage system (Condensation and Purification system), as described in Chapter 3.7. This emission is considered a point source and the main VOC pollutant is benzene and phenol.

Non point source emissions will also occur at the piping network of the HTF, with benzene as the primary pollutant. The estimates of these fugitive emissions are based on the number of loops and pipe joints.

**Table 7-10 Ullage System Emissions**

Pollutant	Emission Rate (kg/h)	Chimney Height (m)	Chimney Diameter (m)	T (°C)	Exit Velocity (m/s)
Benzene	0.006	5	0.59	35	1.95

The Condensate System is designed to operate in that controlled mode and average of 2000 hour per year distributed in 8 hours a day during 8-9 months per year. However the final number of hours of operation of this system is expected to be lower since the actual degradation rate will be lower than the design degradation rate.

### 7.6.1 Initial Impacts

#### Air Emissions Modelling

The main aim of the air quality modelling study is to determine the likely future impacts of the proposed Solar Power Complex on its surroundings and sensitive receptors (existing and future receptors). The model provides predicted concentration contributions of these pollutants at the receptor locations in terms of their sole contributions from the Solar Power. Given that one other point source emission has been identified within the catchment area of

---

the proposed solar plant, this is the boiler for NOORo I, a cumulative modelling assessment has been carried out.

The results are provided in regard to annual mean concentrations and 24-hour or 1-hour mean concentrations, depending on the applicable national standards (to allow comparison).

Air modelling, using AERMOD, was conducted for the proposed plant's boiler and ullage system emissions to assess impacts and verify compliance with National air quality regulations. The analysis consisted of modelling the following pollutant: NO<sub>2</sub>, SO<sub>2</sub>, CO, PM<sub>10</sub>, PM<sub>2.5</sub> and benzene.

The potential impact of the proposed facility on local air quality has been assessed using Breeze AERMOD7, a new generation dispersion model that incorporates the latest understanding of the atmospheric boundary layer and is specially designed to assist the U.S. EPA (Environmental Protection Agency) air quality prediction studies.

#### Local Meteorological Data

The dispersion modelling has been carried out using three years (2012, 2013 and 2014) of hourly sequential meteorological data in order to take account of inter-annual variability and reduce the effect of any atypical conditions. Data from Ouarzazate Airport (approximately 7 km southwest of the facility) has been used for the assessment.

The figures below provide the wind rose for year 2014 and frequency distribution in the Ouarzazate area.

**Plate 7-2 Wind rose for Ouarzazate Airport (2014)**

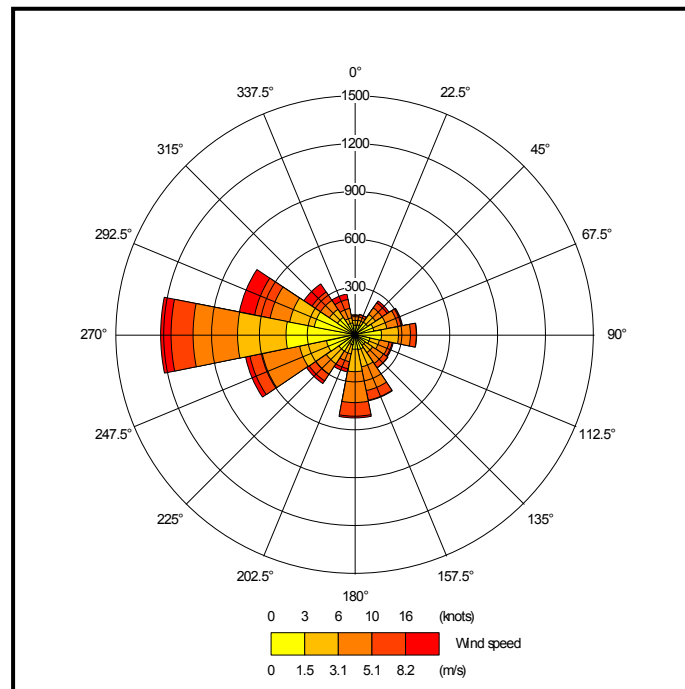

The data show that the prevailing wind direction is from the west. As a consequence receptors to the east are most likely to be affected by emissions from the facility. The velocity is generally within 0.5-2.1 m/s, which is defined as Light Air under the Beaufort Scale, and described as 'leaves and wind vanes would remain stationary'. The highest wind speed attained is approximately 11.1m/s, which is considered a Strong Breeze (Beaufort No. 6), but occurs less than 2.5 % of the time over the course of a year.

**Modelled Receptors**

Chapter 3.4 describes the variety of key sensitive receptors identified within a 15 Km radius of the proposed project, and Figure 3-1 illustrates the locations of these modelled receptors in relation to the proposed project. Given that the predominant wind is from the west, only those sensitive receptors located downwind of the solar plant have been considered in this impact assessment.

**Modelled NOORo I, NOORo II and cumulative CSP project Contributions**

The following tables provide the maximum concentration emission contributions from the individual and combined solar plants, at the receptors, in  $\mu\text{g}/\text{m}^3$  obtained from the AERMOD model.

**Table 7-11 AERMOD predicted maximum concentration values**

Pollutant	Averaging Period	NOORo I	NOORo II	NOORo I&II	IFC/Moroccan $\mu$ g/m <sup>3</sup>
SO <sub>2</sub>	24 Hours	0.56	0.72	0.76	125
SO <sub>2</sub>	Annual	0.008	0.052	0.033	20
NO <sub>2</sub>	1 Hour	4.2	2.6	4.2	200
NO <sub>2</sub>	Annual	0.011	0.072	0.077	50
CO	8 Hours	1.5	1.6	1.9	10mg/m <sup>3</sup>
PM <sub>10</sub>	24 Hours	0.28	0.36	0.38	50
PM <sub>10</sub>	Annual	0.004	0.026	0.027	70(IFC/WB)
PM <sub>2.5</sub>	Annual	0.004	0.026	0.027	35(IFC/WB)
PM <sub>2.5</sub>	24 Hours	0.28	0.36	0.38	75(IFC/WB)
Benzene C <sub>6</sub> H <sub>6</sub>	Annual	0.00011	0.0016	0.0026	10

The subsequent figures show the emissions dispersion pattern for each of the parameters modelled.

The results show that for all parameters, the modelled emissions values are well within the IFC and Moroccan national standards for ambient air quality. Furthermore, given the low emission values, the dispersion models show that the plume quickly dissipates within the first 120m from the emission point, and is halved within the first 300-500m from the emission point.

With respect to the sensitive receptors, the City of Ouarzazate is located 12Km downwind from the project and the town of Tasselmant is located 6.5Km north of the project. In either case, the dispersion model shows that ambient levels of each pollutant will have returned to the background concentrations within the first kilometre from the emission point.

Therefore, impacts from the plants emissions on the sensitive receptors are considered negligible



Plate 7-3 Annual and 24-Hour Emission model for SO<sub>2</sub> - Cumulative

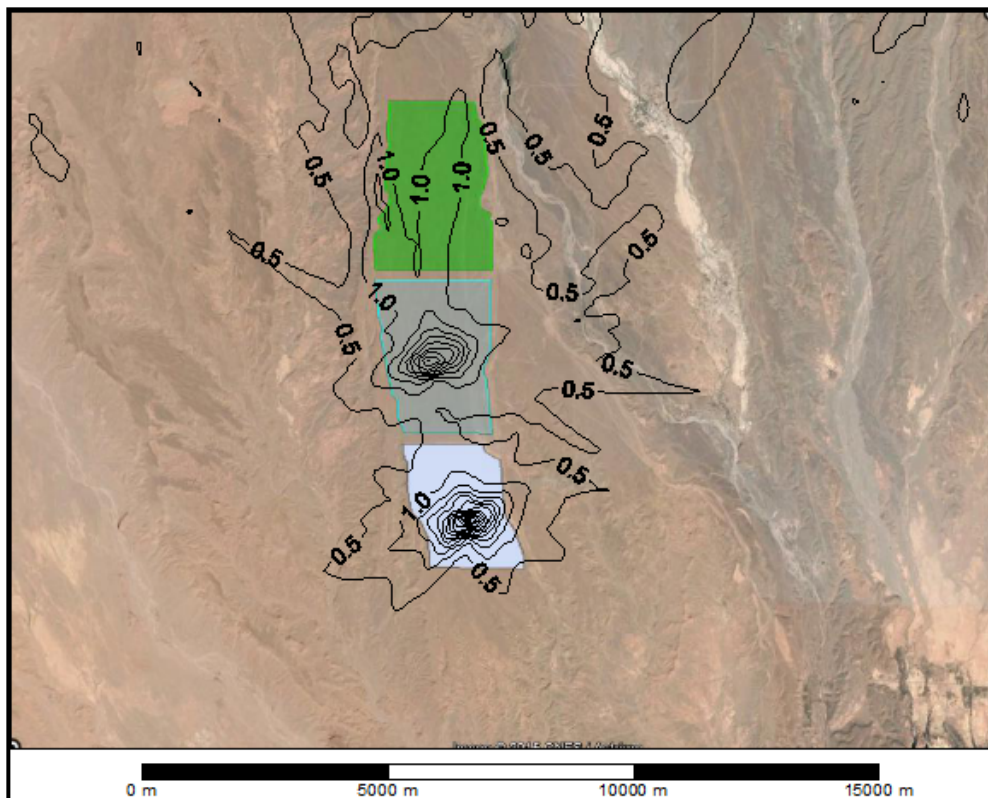
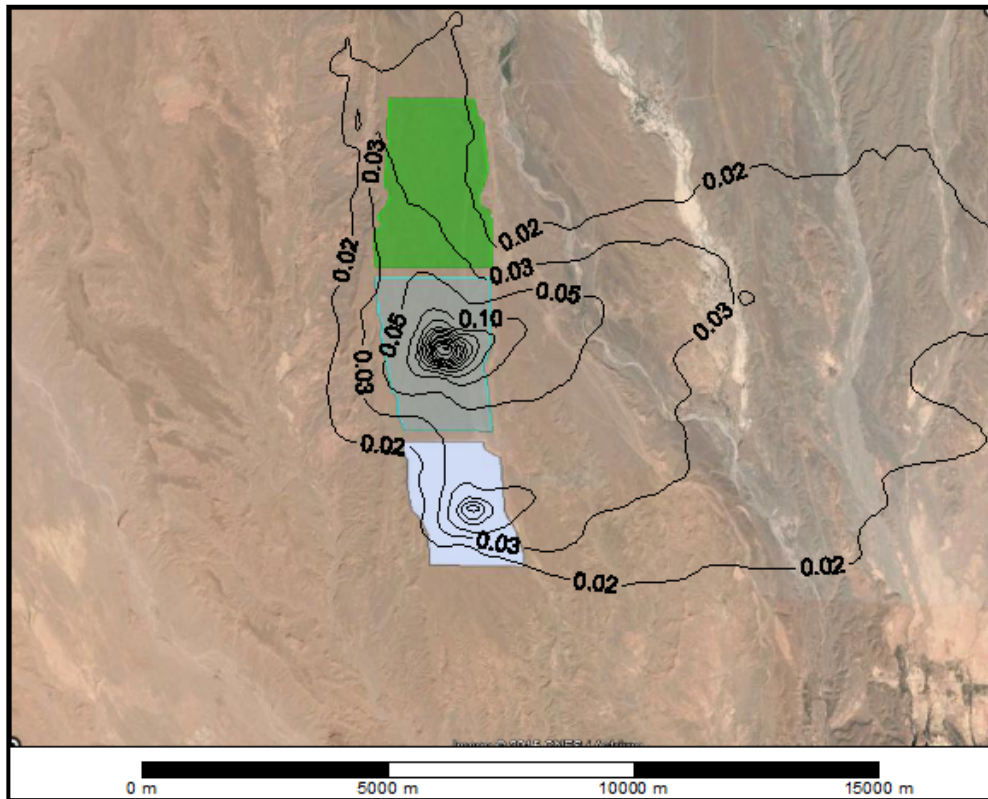



**Plate 7-4 Annual and 1-Hour Emission model for NO2 - Cumulative**

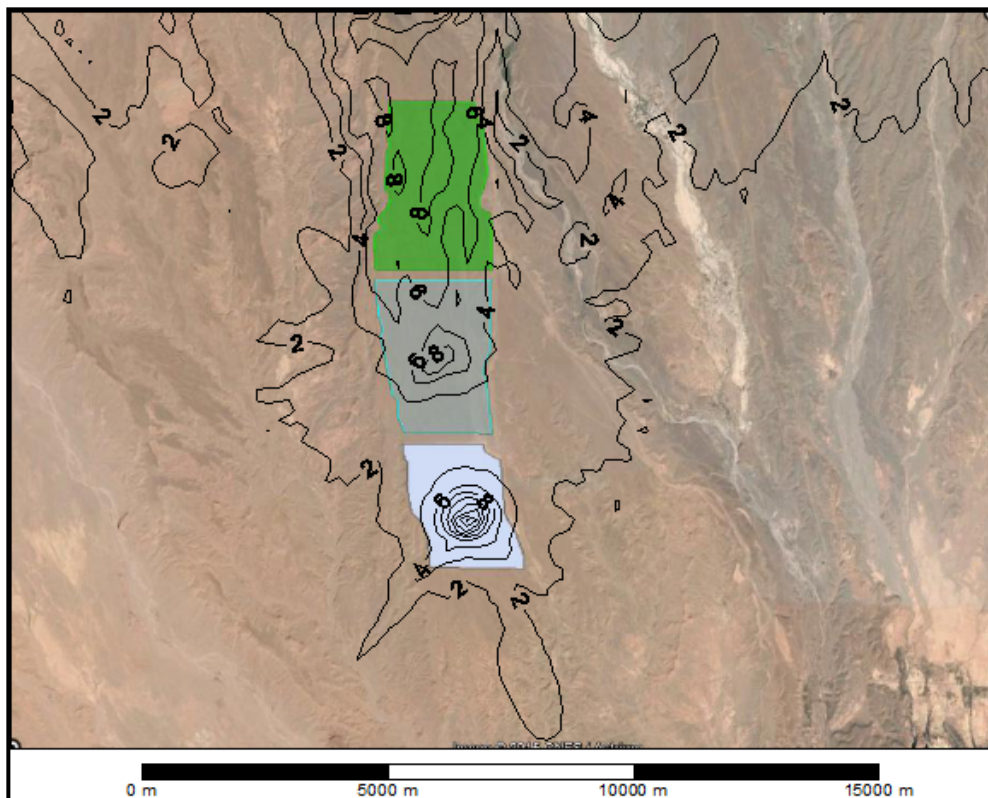
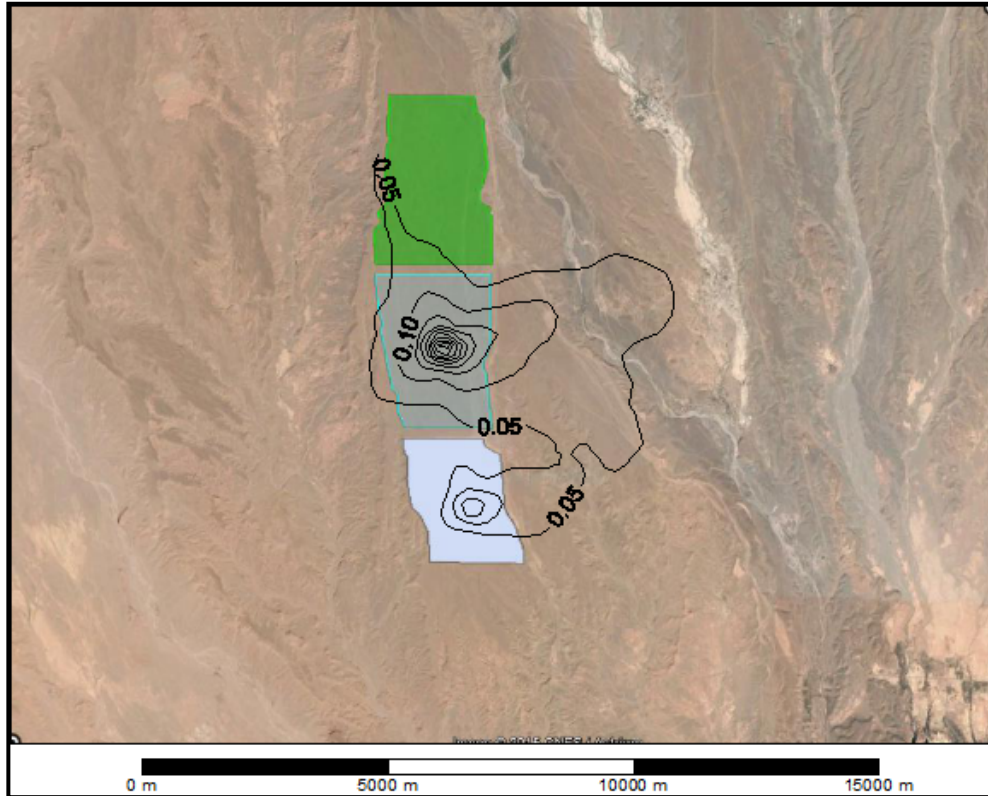

Plate 7-5 8-Hour Emission model for CO - Cumulative

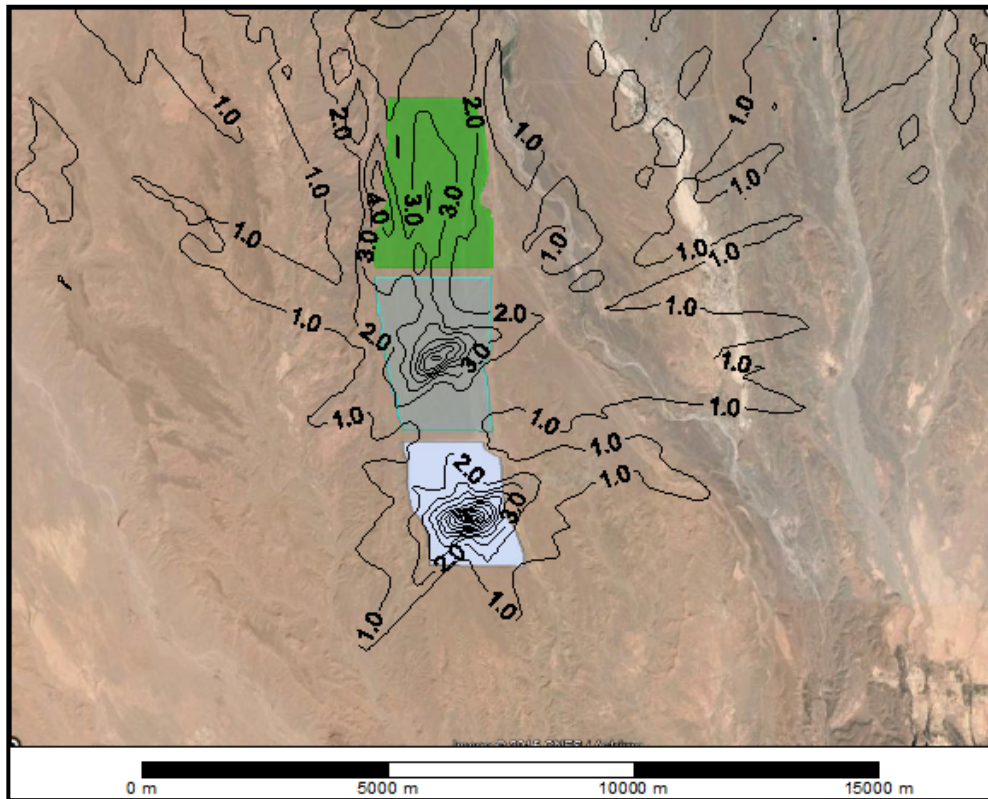

Plate 7-6 Annual mean and 24-Hour Emission model for PM10 - Cumulative

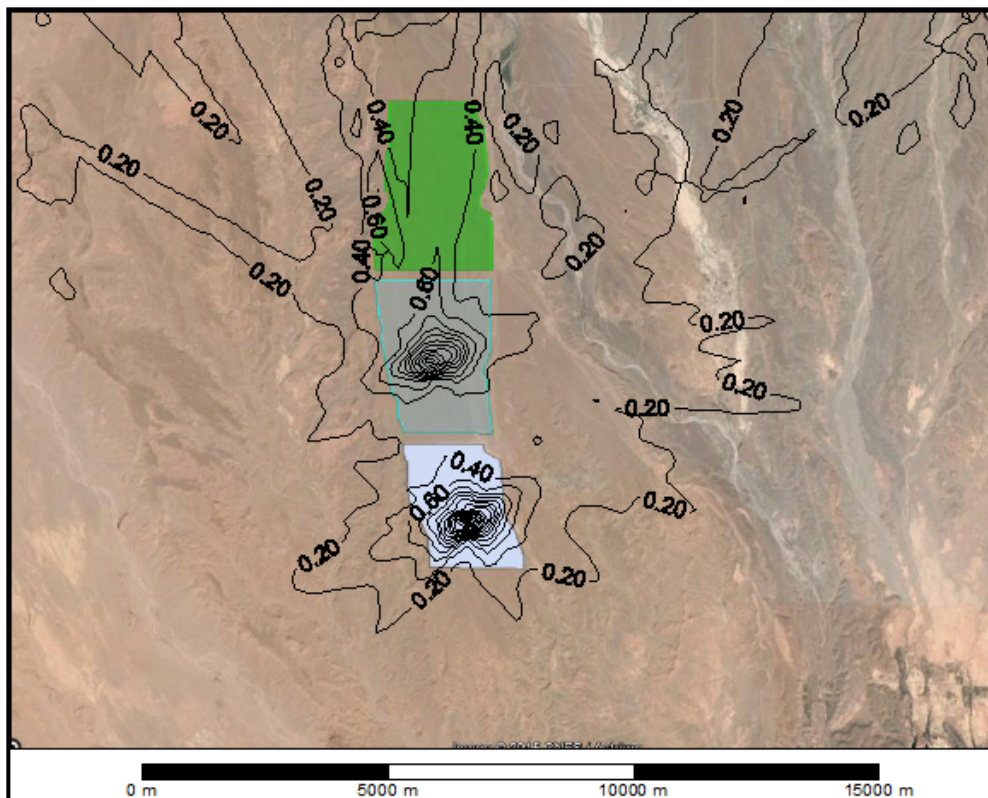
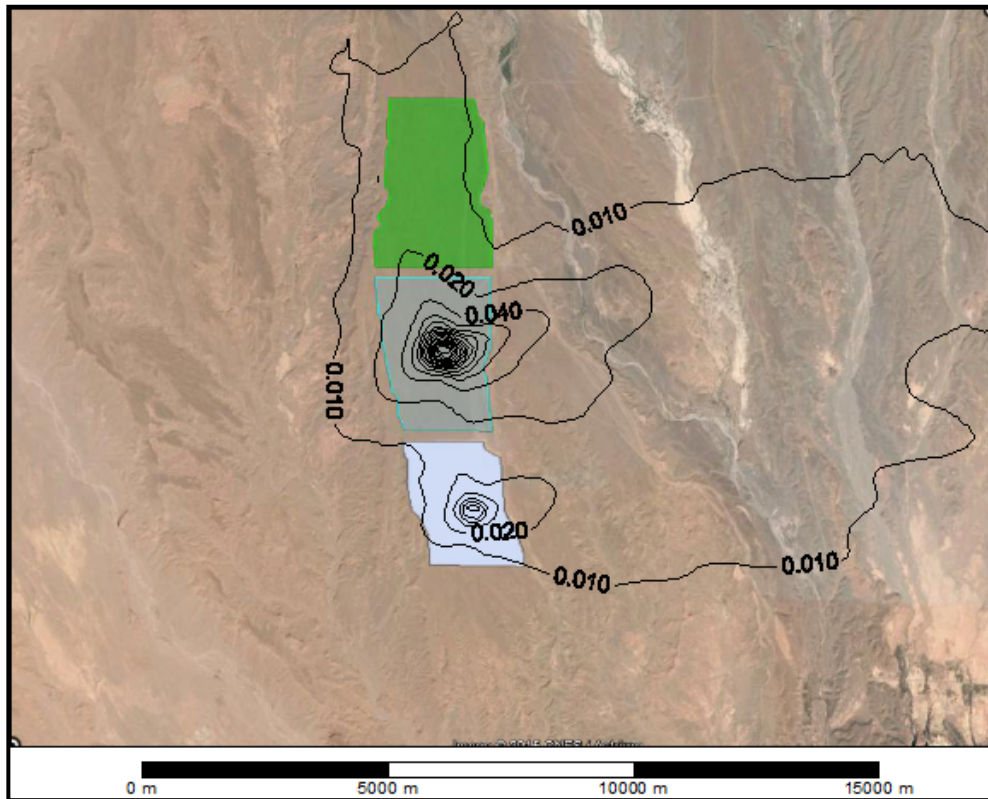



Plate 7-7 Annual Emission model for Benzene - Cumulative

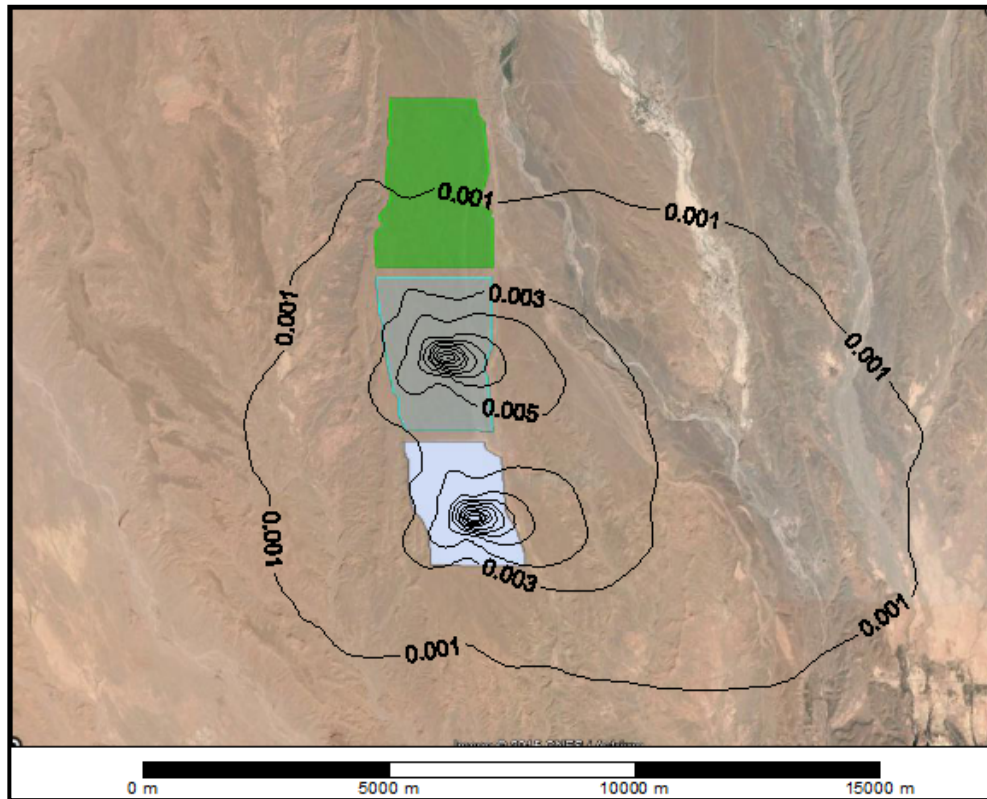

Table 7-12 Air Quality – Magnitude of Operation impacts

Impact	Magnitude	Justification
Air Emissions from Combustion Processes	Minor to negligible	Although the CSP plant will occasionally use diesel fuel to operate the boilers and fugitive emissions from the HTF system may occur, the concentration of emissions and frequency of emissions is low, and compliant with Moroccan and IFC guidelines.
Vehicle Emissions	Minor	The quantities and frequencies of vehicle traffic associated with the operation of the CSP plant plant is minimal.

Table 7-13 Air Quality - Significance of Operation Impacts

Impact	Magnitude	Receptor	Sensitivity	Impact Significance
Air Emissions from Combustion processes	Minor to Negligible	Air Quality	Low	Negligible to Minor
		Tasselmant Village	Medium	Minor
		Power plant employees	Low	Negligible to Minor
Air Emissions from Vehicles	Minor	Air Quality	Low	Negligible to Minor
		Tasselmant Villages	Medium	Minor
		Power plant employees	Low	Negligible to Minor

### 7.6.2 Mitigation Measures

Although the modelling study has shown that the operation of the facility will not have any negative impacts to the air quality, the following mitigation measures will be implemented as a course of best practice in order to ensure that the longterm operation of the facility does not result with any cumulative negative impacts.

- All internal roads within the project will be paved in order to prevent dust generation from vehicle movements.
- Vehicle speeds will be less than 10Km/hr during the mirror cleaning process, and if necessary road wetting will be carried out to suppress dust.
- If it is necessary to protect the plant from dust generation at the outside boundary of the project then barriers could be erected in areas exposed to wind. However, studies to verify material permeability, minimum height and distance from the first loops would be needed in order to avoid shadows.
- Low Sulphur Fuel (<50ppm) will be used for the boilers and all other fossil fuel burning plant. The boilers will have one common exhaust stack. The flue stack will include sample points for the temperature analysis and control of combustion.
- The vent of the condensation tank will be equipped with an active carbon filter to avoid emissions of volatile compounds to the atmosphere.
- The plant will have a nitrogen network to create an inert atmosphere within the salt storage tanks, expansion tanks and HTF heaters.

The proposed system for removal of VOC will be in accordance with BAT (BREF: Best Available Technique Reference Document) of Common Waste Water and Waste Gas Treatment / Management Systems. It is stated that for VOC removal BAT is:

1. Removing VOC from waste gas streams, using techniques (or a combination thereof) described in Sections 3.7
  - Condensation and Adsorption are both appearing techniques in the proposed treatment process.
2. Using recovery techniques such as condensation, membrane separation or adsorption whenever feasible to regain raw material and solvents. Waste gas streams with high VOC concentrations are best pre-treated by techniques such as condensation or membrane separation / condensation to recover the main load before sending them to adsorption, wet scrubbing or combustion.
  - In the case of adsorption and combustion this can also be a safety issue, keeping VOC concentration below 25 % LEL. The proposed design has provided for a double condensation system prior to reaching the adsorption stage.

- To guarantee a safe emission to the atmosphere a final stage of activated carbon adsorption will be implemented. The active carbon filter allows achieving the following levels of HTF System VOC emissions (after treatment):
- Vented VOC flow: < 0.16kg/h
- VOC concentration after treatment < 75 mg Carbon / m<sup>3</sup> (Complies with specification)
- Benzene concentration < 5mg/m<sup>3</sup>
- Phenols, cresols and xylols (as phenols) < 10 mg/m<sup>3</sup>
- Total annual VOC vented < 0.5 T/year

### 7.6.3 Residual Impacts

The air quality modelling study undertaken by the Consortium identified that emissions contributions from the operation of the proposed NOORo II CSP will not adversely affect the existing air quality and that emissions values remain well below the IFC and Moroccan maximum allowable limits for point source emissions.

Following the implementation of an appropriate OESMP (which will at least include the mitigation measures outlined previously), and others as noted within the Environmental and Social Management and Monitoring section, the overall residual effects are expected to be of negligible significance.

**Table 7-14 Air Quality – Residual Impacts – Operation Phase**

Impact	Magnitude	Receptor	Sensitivity	Impact Significance	Mitigation	Residual Impact Significance
Air Emissions from Combustion processes	Minor to Negligible	Air Quality	Low	Negligible to Minor	Yes	Negligible
		Tasselmant Villages	Medium	Minor	Yes	Negligible
		Power plant employees	Low	Negligible to Minor	Yes	Negligible
Air Emissions from Vehicles	Minor	Air Quality	Low	Negligible to Minor	Yes	Negligible
		Tasselmant Villages	Medium	Minor	Yes	Negligible
		Power plant employees	Low	Negligible to Minor	Yes	Negligible

---

## 8 NOISE AND VIBRATION

### 8.1 Introduction

Noise is an environmental impact that will be generated by both construction activities and the operational phase of the proposed NOORo II CSP. Vibration may also be generated by equipment during the construction period but is unlikely to be evident during operations.

This section considers the potential effects associated with the generation of noise and vibration during the construction and operational phases of the proposed project. It includes the results of a baseline noise survey, which was undertaken to establish the existing ambient noise levels in the proposed site and interpretation of analytical noise modelling undertaken to determine operational noise emissions from the plant.

The potential impacts are assessed, mitigation measures considered and the residual impacts reported.

### 8.2 Methodology

#### Noise

This study has been undertaken based on the following:

- Initial identification of the relevant national and international standards and requirements relating to noise during the construction and operational phases.
- An assessment of the likely construction activities and basic modelling of the potential operation phase noise generation (in line with British Standard 5228). The assessment has been made against the permitted standards, IFC and as stipulated in the RFP, with the impacts on workers and nearby receptors noted.
- Determination of required mitigation measures, including noise abatement technologies that might be needed to comply with national and international noise limits. Mitigation measures have been recommended in light of the results of the modelling study and the residual impacts on receptors outside the site and workers at the site predicted.

In order to establish a benchmark of the noise conditions at the site, an environmental noise survey was undertaken in the day and night time starting on February 27<sup>th</sup>.

During this survey, noise monitoring measurements were conducted at nine (9) locations to consider the ambient noise levels within the site and the influence of existing and surrounding noise sources. The following table and figure provide the location details.



The monitoring was undertaken using a pre-calibrated sound level meter, which was connected to a laptop for direct download of the data. A computer software specifically developed for the instrument, then interpolated the data and provided tables and graphs of the noise levels. Measurements were taken for a 15 minute period, in the day time and night time, at each location using a broadband noise setting, within a measurement range of 30-100 dB.

The results of the noise monitoring survey will be used as a benchmark for the programmed noise monitoring activities, which will be implemented for the construction and operation phase within the ESMP.

**Table 8-1 Noise sampling Coordinates**

Monitoring Station	Coordinates		Description	Sampling Time
	North	West		
N2N1	31° 1'20.58"N	6°51'30.68"W	South East corner of NOORo II Plot	15 mn day and nighttime at each location
N2N2	31° 2'33.46"N	6°52'44.54"W	Northwest Corner of NOORo II Plot	
N3N1	31° 3'49.25"N	6°51'25.31"W	Along access road, centre of NOORo III	
N3N2	31° 3'53.59"N	6°52'39.33"W	Centre of West boundary of NOORo III plot	
N3N3	31° 4'47.80"N	6°51'40.71"W	Northeast corner of NOORo III	
N3N4	31° 5'14.29"N	6°51'21.95"W	Village of Tasselmant	
N1N5	30°58'3.97"N	6°50'27.32"W	Junction of N10 with Solar field access road	
N1N6	30°55'38.40"N	6°53'24.83"W	N10 at exit of Ouarzazate City towards project	
N1N7	30°55'48.03"N	6°54'25.73"W	N10 at entrance to Ouarzazate from the west	

Plate 8-1 Noise Survey Location

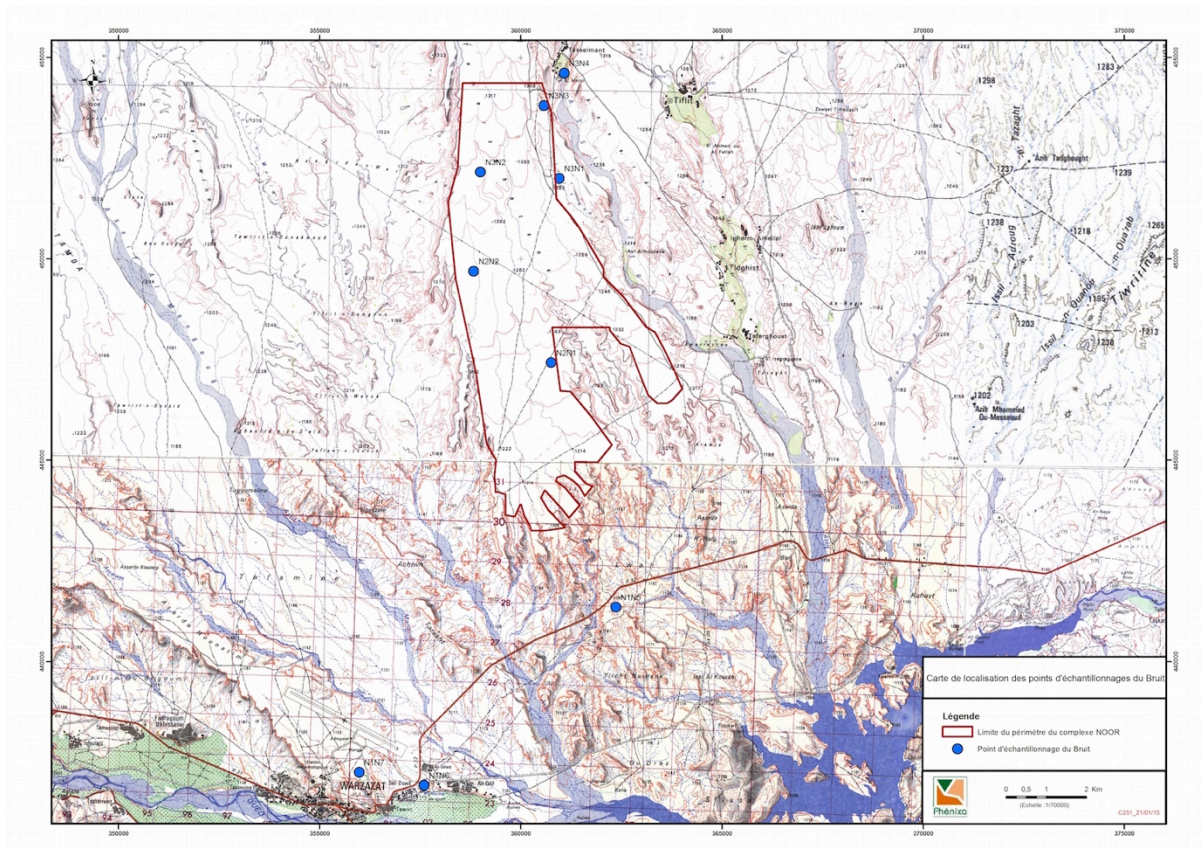

### 8.3 Baseline

#### Noise

The proposed site is located in an isolated area, with no significant developments or commercial activities located within a 6 Km radius. The only identified source of noise is sporadic in nature and emanates from the two roads, which run parallel to the site. In the past, traffic was light and consisted of private vehicles and light commercial trucks.

However, recently, road expansion and construction activities for NOORo I CSP plant have started and as a result noise levels have increased, however this is considered uncharacteristic of the typical historical noise conditions and is temporary in nature.

### Analytical results

The following tables provide the measurements for noise levels collected at the 9 locations.

**Table 8-2 Noise Monitoring Results, Day Time**

Monitoring Station	Measured Noise Level Day Time		
	Leq, dB (A)	Lmax dB (A)	Lmin, dB (A)
N2N1	55.5	74.7	49.8
N2N2	46.0	70.2	35.8
N3N1	43.6	69.3	30.4
N3N2	41.9	68.7	33.8
N3N3	37.9	73.7	26.7
N3N4	43.1	68.1	33.6
N1N5	49.3	75.9	38.7
N1N6	60.2	82.4	49.9
N1N7	63.6	84.7	51.1

**Table 8-3 Noise Monitoring Results, Night Time**

Monitoring Station	Measured Noise Level Day Time		
	Leq, dB (A)	Lmax dB (A)	Lmin, dB (A)
N2N1	61.1	82.5	49.9
N2N2	55.5	81.8	44.6
N3N1	45.3	66.8	45.3
N3N2	57.1	70.1	45.2
N3N3	49.1	70.6	38.0
N3N4	45.1	66.9	38.8
N1N5	57.7	81.2	46.8
N1N6	65.6	85.3	51.4
N1N7	57.3	77.5	42.5

**Table 8-4 Noise Monitoring Results, Average**

Monitoring Station	Average Sound Level dB	
	Day	Night
N2N1	55.5	61.1
N2N2	46.0	55.5
N3N1	43.6	45.3
N3N2	41.9	57.1
N3N3	37.9	49.1
N3N4	43.1	45.1
N1N5	49.3	57.7
N1N6	60.2	65.6
N1N7	63.6	57.3

The wind speed, during the monitoring period, was weak with a minimum of 0.5m/s and a maximum of 12.3m/s. The predominant direction was SE-NW.

Generally, both the day time and night time noise levels at the boundaries of the SPC, reflect a quiet, undeveloped area. The levels do not change significantly between night and day and they are below the maximum allowable noise limits for residential areas.

The average noise levels along the road, reflect typical noise levels that would be generated by light traffic. Additionally, there is no significant change between the night and day readings, and in comparison to the Industrial/Commercial limits, the levels are compliant.

### Vibration

The impacts due to vibration have been determined by considering the likely construction and operational processes involved at the proposed NOORo II CSP project site. As such, a discussion of the impacts and any necessary mitigations measures has been provided in the following sections.

In terms of a baseline, no noticeable vibrations were encountered on the site during the site visits. It is anticipated that very low level vibration may occur on the southern and eastern boundary of the site where the NOORo 1 CSP plant is being built and the new road runs adjacent to the boundary. No other industrial facilities are located within 15 km radius of the site, therefore off-site vibrations are not anticipated.

## 8.4 Sensitive Receptors

The table below outlines the identified receptors in relation to noise and vibration as well as the determined sensitivity of those receptors.

**Table 8-5 Noise/Vibration - Receptors sensitivity**

Receptor	Sensitivity	Justification
Construction Workers / Operators	High	Constructions workers are sensitive receptors for noise as they are directly exposed to noise impacts.
Tasselmant Village	High	The residential areas is considered a high sensitivity receptor for noise, particularly at night time.
Employees of the NOORo 1 CSP plant	High	Operation workers are sensitive receptors for noise as they are directly exposed to noise impacts.

## 8.5 Construction Assessment

### 8.5.1 Initial Impacts

At this stage of the project it is envisaged that the construction activities, are likely to include the following:

- Site preparation - back-filling, levelling and grading and the removal of made ground in areas where foundations are to be installed. It is assumed that these activities will require the use of dozers, excavators and muck-away lorries.
- Civil Works – Piles will be required for some of the building and plant foundations during this phase. On the basis on on-going construction methodologies at the NOORo 1 CSP plant site, it is assumed that cast in-situ bored piles and driven piles will be required.
- Construction and Installation - This phase of works is assumed to involve the casting of reinforced concrete slabs 'in-situ', blockwork, steel/scaffold erection and the installation of plant etc. It is assumed that these works will require the use of concrete truck mixers, compressors, generators, heavy lifting equipment (including cranes) and hand tools.
- Drainage and road paving - This stage of the works will comprise of several operations that will likely include excavation for and laying of drainage pipes and road surfacing.

With regard to the impacts upon ambient noise levels, a basic assessment of the likely construction noise levels to be experienced at the site boundary has been undertaken in regard to the expected construction plant/machinery to be used at the site. This basic assessment is provided below, but it will be noted that the predicted noise levels are indicative and are subject to variables including location, buildings, specifications of construction plant (including power output, silencers etc) and works phasing.

Noise data for the likely plant/equipment to be used at the site has been obtained from 'BS:5228, British Standards: Code of practice for noise and vibration on construction and open sites'. Noise values for likely site plant/equipment have been set out in Table 8-6. These noise levels represent the typical magnitudes observed at 10m from the operation of the construction plant.

**Table 8-6 Noise Level of Anticipated site Plant/Equipment**

Construction Plant	BS:5228 Noise level at 10m (db(A))	BS:5228 Reference
Excavator	79	C.2, 14
Loader	82	C.6, 33
Motor lorry	80	C.2, 34
Scraper/leveller	82	C.5, 8
Roller	80	C.5, 19
Asphalting machine	84	C.5, 32
Truck mixer	80	C.4, 18
Concrete-pumping machine	80	C.4, 29
Truck crane	77	C.4, 53



Stationary crane	77	C.4, 49
Generator	84	C.4, 84
Motor-driven compressor	75	C.3, 19
Fork Lift	67	C.4, 57
<b>Cumulative noise at 10m assuming 50% on time</b>	<b>89</b>	

For the assessment it is assumed that each item of plant/equipment is utilised at approximately half its operational capacity (over a given period of time), rather than continuously at full power; as is typical with any construction process. A 50% on time factor has therefore been applied in the calculation.

As such, the accumulation of the noise levels from all the above equipment at a reception point 10m away will be approximately 89 dB(A). It will be noted that this basic assessment assumes that the noise is being received at a distance of 10m from the source and does not account for any other background noises.

It is known that noise levels dissipate with distance propagation and the following table (Table 8-7) sets out the anticipated noise levels at distances from the construction sources. The propagation due to distance has been calculated from the appropriate attenuation formula for distance, as set out in the BS:5228 British Standard.

**Table 8-7 Construction noise levels in terms of distance from the source**

Distance from Construction Works (m)	Noise Level dB (A)
10	89
20	83
50	73
100	66
200	58
300	53.6
500	48.1
1000	40.6

The above table demonstrates that the attenuating effects of distance on a noise source is profound; reducing noise levels when at greater distances from the source. Given the expanse of the site, and that the power island will be located at the centre of the solar field, the construction activities on site are unlikely to affect the offsite ambient noise levels.

Prior to the implementation of mitigation measures, this impact can be assessed as being of minor negative significance. However, measures will be introduced to reduce noise levels when working in close proximity to the site boundary, as they could exceed the required standards without mitigation. It is likely that at certain locations of the site, noise levels will be in excess of 85 dB(A), for which ear protection would be required for the personnel on site. Such areas will include those immediately next to plant or machinery. Prior to the mitigation measures, the impact to workers can be deemed to be of a minor to moderate negative impact.



### Assessment of Impacts - Vibration

Certain construction processes, particularly those involved with site preparation and civil works, e.g. ground breaking and excavations, have the potential to create vibrations within the vicinity of the works. Vibrations are also anticipated to occur sporadically around the construction site due to the movement of materials and equipment. However, due to the isolated nature of the site and lack of sensitive receptors within its vicinity, any vibrations caused during construction are unlikely to provide impacts.

The nearest receptors to the site are the towns and cities to the north and south of the NOORo II CSP. As vibration dissipates rapidly with distance (due to its spreading loss from the source), there are anticipated to be few and minor vibration impacts due to construction upon sensitive receptors. Due to the nature of earthworks being relatively minor, it is unlikely that the impacts upon the surrounding receptors caused by vibration will be significant (in terms of disturbance to humans or damage to structures). Where any vibration impacts do occur they will be temporary in nature. Prior to the implementation of mitigation measures, this impact can be assessed as being negligible.

Vibration impacts to construction workers may directly occur to those who are in operation of vibration creating machinery or, who are in close proximity to piling and excavation works. Such impacts may include 'white finger', which is typically caused by the use of vibrating hand held machinery.

**Table 8-8 Noise and Vibration - Magnitude of Construction Impacts**

Impact	Magnitude	Justification
Construction Noise	Minor	The majority of noise impacts are not anticipated to result in exceedances of the standards at the site boundary or in significant impacts to offsite receptors
Construction Vibration	Negligible	Very minor vibration impacts may occur during construction works, which will be limited to the site
Construction Vehicle Noise (off site)	Minor	Adverse impacts may occur to receptors adjacent to local roads in proximity to the site, if vehicle flows significantly increase due to construction.

**Table 8-9 Noise and Vibration - Significance of Construction Impacts**

Receptor	Sensitivity	Impact	Magnitude	Impact Significance
Construction Workers / Operator	High	Construction Noise	Minor	Minor to Moderate
		Construction Vibration	Negligible	Minor
		Construction Vehicle Noise (off site)	Minor	Moderate to Major
Tasselmant Village	High	Construction Noise	Minor	Minor to Moderate

		Construction Vehicle Noise (off site)	Negligible	Minor
Employees of NOORo 1	High	Construction Noise	Minor	Minor to Moderate

### 8.5.2 Mitigation Measures

The following measures will be considered where appropriate and will be implemented throughout the construction of the NOORo II CSP:

- Activities with highest noise emissions will be undertaken during daytime hours between Monday and Friday and not during official holidays;
- Diesel engine vehicles and compression equipment will be equipped with effective silencers;
- Electrically powered plant will be preferred, where practicable, to mechanically powered alternatives. All mechanically powered plant will also be fitted with suitable silencers;
- Where appropriate, bored piling techniques will be considered in preference to impact piling;
- Delivery vehicles will be prohibited from waiting within or near the site with their engines running. The movement of heavy vehicles during the night will be avoided wherever practical;
- When working in close proximity to the site boundary, extra care will be taken to ensure the mitigation measures in use are effective.
- Independent noise monitoring will be undertaken as appropriate to demonstrate that noise levels at the site boundary are acceptable and within the RFP specified limits;
- Items of plant on site operating intermittently will be shut down in the intervening periods between uses;
- The contractor and their sub-contractors will, at all times, carry out all work in such a manner as to keep any disturbance from noise and vibration to a minimum;
- Where appropriate, noise barriers /attenuation to be employed (e.g. for generators) to ensure that the maximum noise level at 1 m distance from a single source will not exceed 85 dB(A); and
- Where noise levels exceeds 85dB(A) noise protection devices shall be provided to personnel on-site.
- If particularly noisy works are scheduled, these will be undertaken within the daytime and the nearest sensitive receptors informed to the timing and duration of the nuisance.

- Operators of vibrating hand held machinery will be provided with appropriate PPE (e.g. protective gloves) and be given suitable breaks from using such equipment to reduce the impacts of vibration.

### 8.5.3 Residual Impacts

**Table 8-10 Noise and Vibration – Residual Impacts – Construction Phase**

Receptor	Sensitivity	Impact	Magnitude	Impact Significance	Mitigation	Residual Impact Significance
Construction Workers / Operator	High	Construction Noise	Minor	Minor to Moderate	Yes	Minor
		Construction Vibration	Negligible	Minor	Yes	Negligible
		Construction Vehicle Noise (off site)	Minor	Moderate to Major	Yes	Minor
Tasselmant Village	High	Construction Noise	Minor	Minor to Moderate	No	Minor to Moderate
		Construction Vehicle Noise (off site)	Negligible	Minor	No	Negligible
Employees of the NOORo 1 Plant	High	Construction Noise	Minor	Minor to Moderate	No	Minor to Moderate

## 8.6 Operation Assessment

### 8.6.1 Initial Impacts

The RFP provided by MASEN has stipulated specific on-site noise levels which will be complied with during the operation of the NOORo II CSP.

**Table 8-11 RFP Noise Requirements**

Location	One Hour LAeq (dBA)
At one (1) meter outside the Plant fence/boundary when all equipment is running	60
At one (1) meter away from open air installations	85

Within the central control room	50
Within other machine rooms, workshops, etc	85

The operation of the NOORo II CSP project will not include the use of heavy machinery and equipment. The main plant which are likely to emit high noise levels are within the power block (BOP) and include the steam turbines, cooling condensers, HTF pumps, compressed air systems etc. Such processes are likely to be continuous and sustained during daily activities, due to the 24 hour operation of the plant. By contrast the solar field area will not contribute any significant noise levels.

A preliminary noise modelling study was undertaken by the consortium, using CADNA-Av.4.3 software from DATAKUSTIC. The simulation was based on the sound pressure levels at 1 m from the main noise sources in the power block at normal operating conditions. The results are depicted in the following graphics and table below.

**Table 8-12 Summary of Expected noise levels from the NOORo II CSP plant**

Source	Modelled Maximum Noise	Likely Hours of operation	Noise Level
Turbines	85 dB(A) @ 1m	24hrs	Moderate (40-70)
Water pumps	85 dB(A) @ 1m	24hrs	Loud (70-90)
Compressed Air	85 dB(A) @ 1m	24hrs	Moderate (40-70)
Cooling Towers	85 dB(A) @ 1m	24hrs	Moderate (40-70)
HTF Main Pump	85 dB(A) @ 1m	24hrs	Loud (70-90)

Plate 8-2 Solar field preliminary noise map

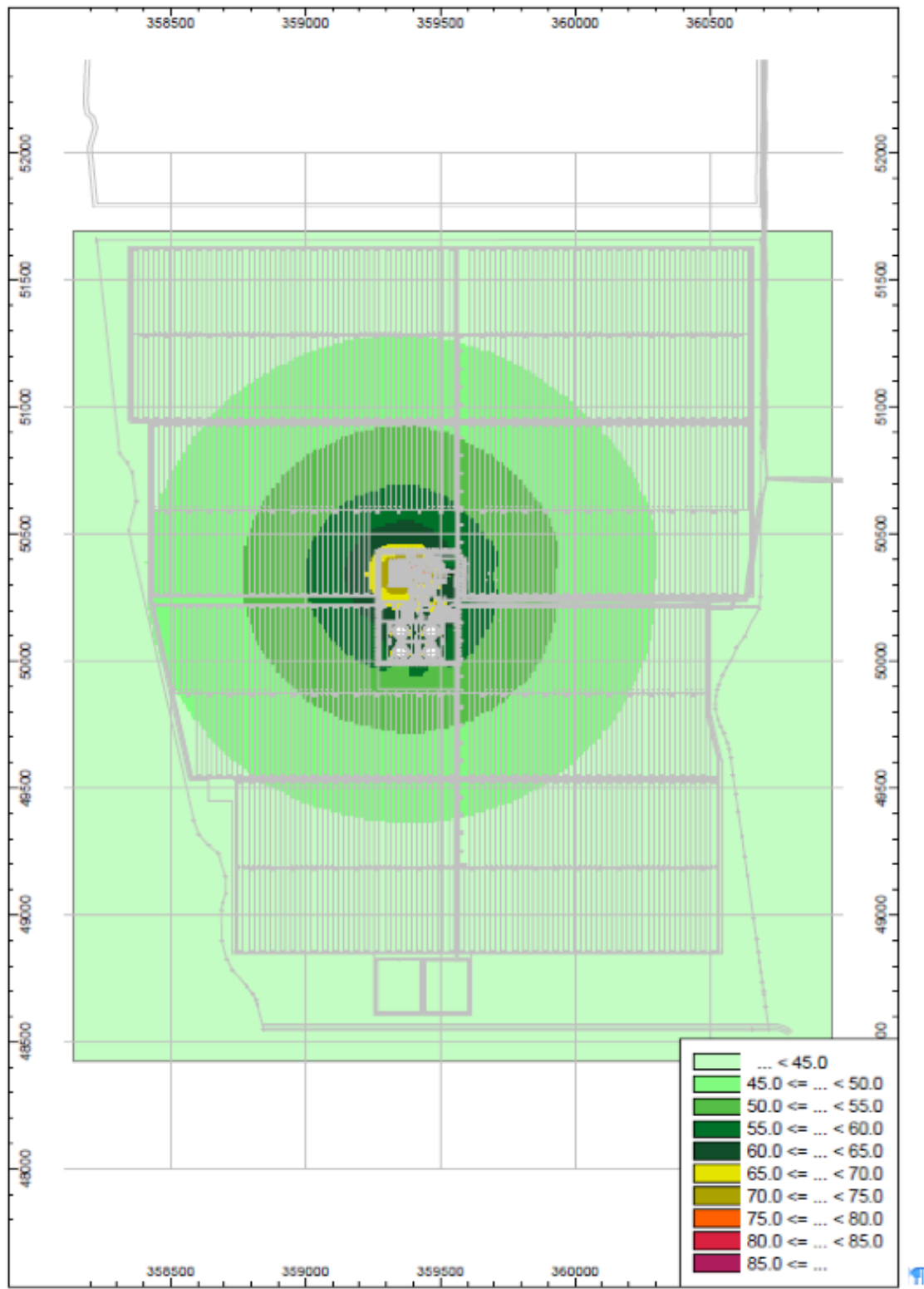
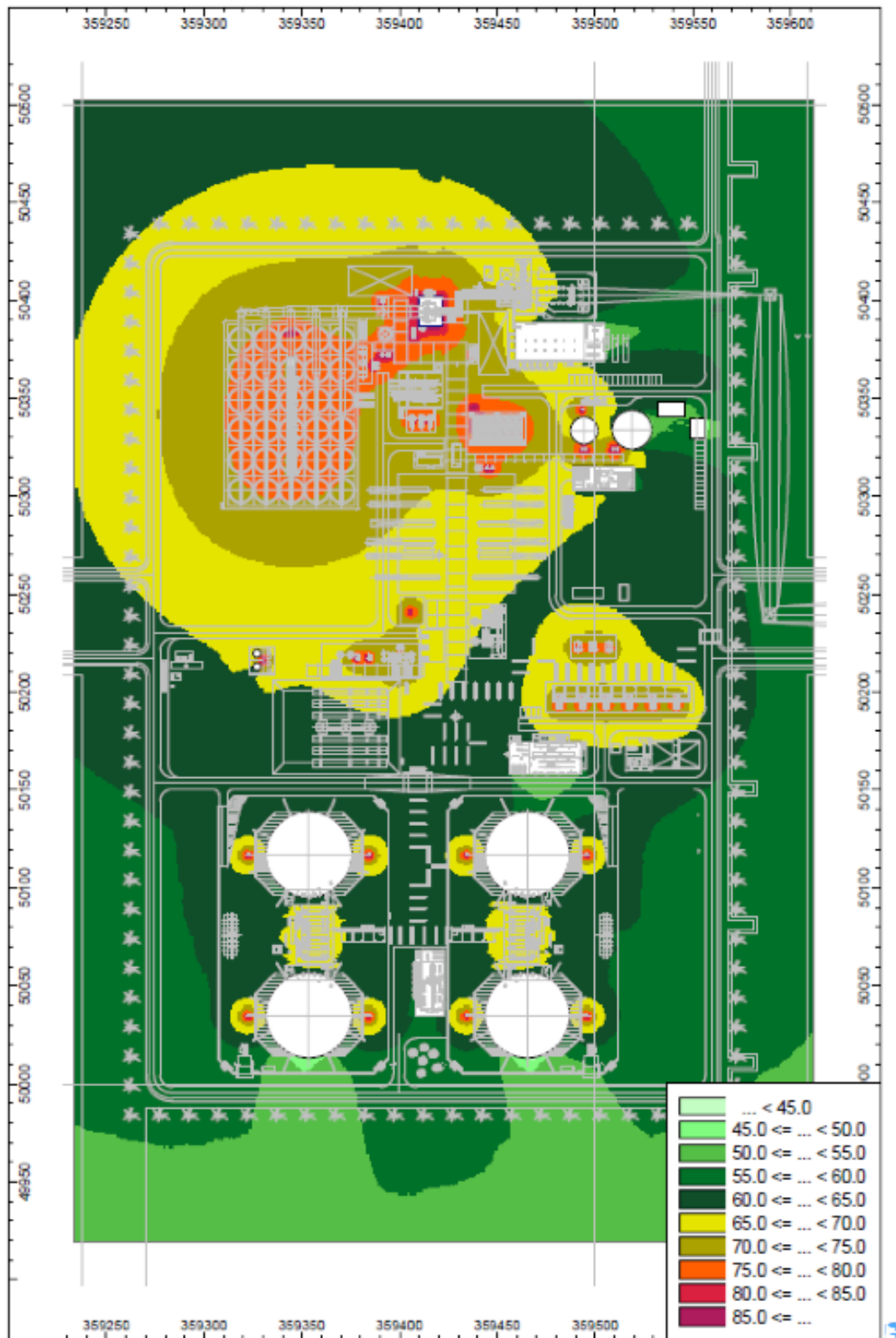

Plate 8-3 Power Island preliminary noise map





The maximum collective plant noise at the site boundary was estimated at 44.9dB. Within the plant's BOP boundary the model showed that the maximum attained noise level was 75dB, and the maximum noise level attained at the site offices was 60dB.

Due to the continuous nature of the operations, it is anticipated that the noise impacts are likely to resemble humming noises, combined with sporadic noises from certain processes, mobile equipment and moving vehicles. Noise levels may increase during transient (start-up) operation, however it is not likely to exceed the IFC noise limits if left untreated.

Given the arrangement of the facilities with respect to the offices it is unavoidable that one or two of them will be located closer to the offices. It will be noted that the site layout has ensured that the loudest noise sources are furthest away from the sensitive on-site receptors. The predicted noise impacts are "freefield" outside the buildings and therefore the noise levels experienced by workers inside will be considerably reduced by the building façade and the window glazing etc.

In addition, the distance at which these noises have to travel will still result in propagation and a reduction in the noise levels when encountered at these receptors. Furthermore, due to the built up nature of the site and intervening structures between the noisy processes and the sensitive receptors, there is likely to be reflection, which will also reduce the noise level at the reception point.

The potential magnitudes of these impacts have been assessed as being of moderate negative significance, prior to the implementation of any mitigation measures.

In terms of vibration, the processes involved during the operational phase of the project are not anticipated to result in impacts at or surrounding the site. Any vibrations that may occur during operation are likely to be sporadic in nature (e.g. from plant/vehicle movements) and would dissipate effectively over distance. Therefore, vibration during operation is not envisaged to result in impacts to nearby or site receptors and can be deemed as neutral.

**Table 8-13 Noise and Vibration - Magnitude of Operation Impacts**

Impact	Magnitude	Justification
Noise from pumps and other plant within the CSP plant facility	Minor	Solar power plants are typically relatively quiet in operation and nuisance from noise is not anticipated.

**Table 8-14 Noise and Vibration - Significance of Operation Impacts**

Impact	Magnitude	Receptor	Sensitivity	Impact Significance
Noise from pumps and other plant within the CSP plant	Minor	Employees of the CSP plant	High	Minor

### 8.6.2 Mitigation Measures

With regard to normal operation, the following mitigation measures will be required:

- All equipment specifications, will limit near field noise to 85 dB(A) at 1m.
- The turbine and/or other potentially sound-producing outdoor equipment will be acoustically protected using cabins or other surrounding devices to reduce the noise impact on the environment, thus ensuring no exceed occur in noise levels.
- Where equipment and plant exceed 85 dB(A) at 1m under typical operating conditions, noise suppression techniques will be developed, these may include: silencers, noise insulation, noise attenuation barriers and housing for equipment. This will be determined and validated during performance testing.
- Buildings used for storing equipment where there are no workers will be designed with cladding that provides the necessary sound-proofing to comply with the limits set in the entire perimeter of the building.
- All pumps will incorporate primary vibration measurement elements.
- Areas of high noise (>85 dB (A)) will be designated as such and it will be mandatory for site personnel to wear hearing protection within these areas.
- All machinery will be adequately maintained in order to minimise sound emissions.
- Silencer performance specifications will be provided to allow the plant to maintain compliance with the noise limits during start-up.
- Ongoing noise monitoring will be carried out at the CSP plant and at sensitive receptors to ensure noise levels are within regulators specifications. The analytical results provided above will be used as the basis for verifying that the noise conditions at the operational stage have not significantly changed from the background and not negatively impacting the neighbouring sensitive receptors.
- Noise surveys and/or modelling will be carried out by the appointed EPC at the commissioning stage, to ensure that the equipment operates within the acceptable levels stipulated by MASEN and IFC regulations for industrial areas. If necessary, further mitigation measures will be implemented based on the modelling results. Noise

performance testing will then be undertaken to validate any modelled observations and to ensure that legislative requirements are being complied with.

### 8.6.3 Residual Impacts

**Table 8-15 Noise and Vibration – Residual Impacts – Operation Phase**

Impact	Magnitude	Receptor	Sensitivity	Impact Significance	Mitigation	Residual Impact Significance
Noise from pumps and other plant	Minor	Employees of the CSP plant	High	Minor	Yes	Negligible

## 9 SOLID AND HAZARDOUS MATERIALS

### 9.1 Introduction

This chapter provides an assessment of the environmental impacts that may occur as a result of waste generation during both the construction and operational phases of the NOORo II Solar Power Complex. Additionally, activity specific mitigation measures are recommended to address the identified potential impacts.

Waste is an undesired by-product of every industrial development, contributing to a number of environmental problems, such as soil contamination from hydrocarbon leaks and heavy metals. If not properly disposed and/or contained, direct contamination to the groundwater and indirect contamination to sensitive receptors is likely. With proper management, a large amount of discarded non-hazardous materials can be recovered and either reused directly or disassembled and their components reutilised. With regard to the hazardous material, these would be appropriately treated and disposed in order to prevent direct and indirect contamination events.

The construction and operational phases of the proposed Project will necessitate the proper management of solid and hazardous materials used or created on site. This also includes the generation of domestic waste and storage of hazardous and non-hazardous materials or wastes and the proper management of excavated material.

### 9.2 Methodology

The main objective of this chapter is to assess the impacts associated with the generation, handling, storage and transportation of waste material during both construction and

operational phases of the Project. This assessment has been informed through a desktop study, site visit, and an overall understanding of waste management issues gained from assessing the environmental impacts of other industrial facilities. The following specific information has been reviewed as part of the desk study:

- Assessment of applicable national and international standards and guidelines identified within the IFC / World Bank Performance Standards;
- Assessment of available site specific information relating to waste generation;
- Assessment of the proposed design, construction procedures and project features that may impact on both the society and environment in terms of waste generation; and
- Walkover survey; to identify sensitive receptors and determine the existing baseline conditions.

Based on the findings of the assessment, measures have been identified in order to mitigate any negative effects and promote positive effects associated with both the construction and operational phases. General waste management practices are evaluated with respect to legal requirements and where applicable, mitigation measures resulting in the improvement of waste management and waste minimisation are recommended.

The main aims of the chapter are to identify the following:

- Options for the reduction, re-use, recycling and recovery of all waste streams;
- Opportunities to minimise waste streams from Project inception, thereby minimising the amount of waste sent to landfill;
- Specify methods for the segregation of waste streams within the facility; and
- Specify the requirement for a clear, comprehensive Waste Management Plan to be integrated into the CESMP for the operational phases. Inclusion of detailed methods for appropriate storage, transfer and disposal of both hazardous and non-hazardous waste streams.

### **9.3 Baseline**

Solid waste generation in Morocco is growing rapidly due to significant industrial and economic growth. Consequently, responsible waste management is essential to minimise direct and indirect impacts upon the environment as a result of waste generation and resource consumption. Rapid economic development often precedes the required infrastructure to handle the wastes generated. Therefore, in order to allow sustainable and environmentally friendly economic development of Morocco, it is vital to consider the methods for handling, storage and management of waste generated in conjunction with progress in a country's economy.

Waste management sites and facilities in Morocco are operated and managed by private companies or local municipalities. When new sites are proposed and constructed, the regulator plays an important role in advising the operators on the environmental protection requirements for each facility.

### **Waste Characterisation**

Waste can exhibit certain characteristics according to the process stream from which it is generated and any pre-treatment processes that are undertaken. Different types of waste require different management and disposal techniques according to the potential risk that the material poses to human health or the environment. In order to categorise the different risks to these receptors, it is often useful to demarcate the streams into 3 main categories that effectively equate to the level of the management and disposal which are required for each:

- Hazardous waste - materials which pose a potential hazard to the environment or health of employees or the general public;
- Non-hazardous wastes - solid materials which are not hazardous and degrade, chemically or biologically in the environment; and
- Non-water soluble wastes - materials that do not breakdown in the environment, and are otherwise inert.

Hazardous waste exhibits any of the following characteristics:

- Ignitibility - Ignitable waste can create fires under certain conditions, are spontaneously combustible, or have a flash point less than 60 °C (140 °F). Examples include waste oils and used solvents.
- Corrosivity - Corrosive waste are acids or bases (pH less than or equal to 2, or greater than or equal to 12.5) that are capable of corroding metal containers, such as storage tanks, drums, and barrels.
- Reactivity - Reactive waste are unstable under "normal" conditions. They can cause explosions, toxic fumes, gases, or vapours when heated, compressed, or mixed with water. Examples include lithium-sulphur batteries and explosives.
- Toxicity - Toxic waste are harmful or fatal when ingested or absorbed (e.g., containing mercury, lead, etc.).

It is considered likely that the proposed Phase 1 Ouarzazate Solar Power project may use or generate hazardous materials in all of the categories listed above.

### **Waste Management Hierarchy**

The waste management hierarchy is a key element of waste management. Minimising the amount of waste to be stored and disposed of not only protects the environment but also has the potential to reduce costs that may be incurred by the main contractor or the proponent for handling and disposing of the waste.

The waste hierarchy, typically expressed in the “3 R's” of waste management (Reduce, reuse, recycle) is illustrated in the following Figure.

**Plate 9-1 Waste Hierarchy**

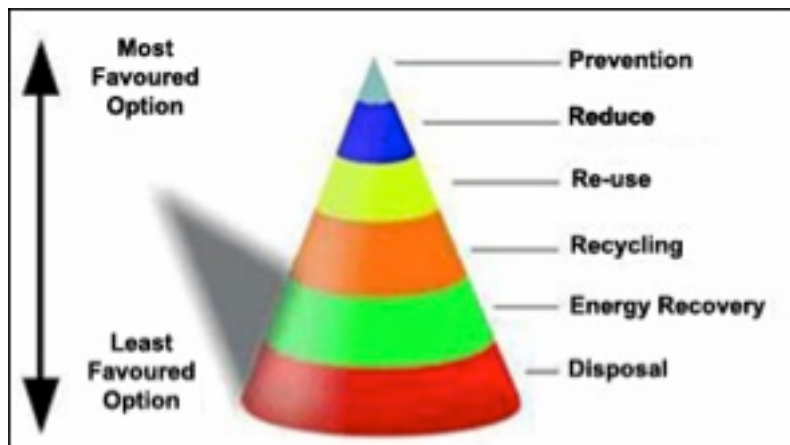

In general, waste generation is evaluated according to the waste minimisation approach. This approach is common to various national and internal guidelines and principles and involves the following steps in decreasing order of importance.

- Prevention;
- Reduce;
- Reuse and recycling;
- Recover; and
- Land filling.

Initially, options to prevent or reduce waste should be considered. Where waste generation cannot be avoided or further reduced at source, opportunities for reuse of materials should be explored, either for use for the same or a different purpose. Disposal to landfill is the least favoured option in the waste hierarchy and is the last resort after all other options have been considered.

#### **9.4 Sensitive Receptors**

The following are considered to be project specific sensitive receptors during both construction and operational phase of the facility:



Local landfills within the vicinity of the Project Site represent potential sensitive receptors, since the construction and operational phases will result in an additional input of waste materials into these landfills.

The generation of both hazardous and non-hazardous wastes will be expected. The municipality of Ouarzazate has a licensed waste company that handles industrial and domestic wastes. The handling and disposal of hazardous wastes will follow the regulations of law no. 28-00 for waste management and will also meet international best practice (IFC Guidelines).

The soil within the Project Site is also considered a sensitive receptor. In the event of any spills or leaks of hazardous waste materials, contamination to soils may occur.

**Table 9-1 Solid and Hazardous Waste - Receptors sensitivity**

Receptor	Sensitivity	Justification
Soil & Groundwater	Medium	Hazardous waste will be stored on site, in the event of any spills or leaks of hazardous waste materials, contamination to both soil and groundwater may occur.
Local Landfill	High	The construction and operation phases will result in an additional input of waste materials into these landfills. Both hazardous and non-hazardous wastes will likely be generated.

## 9.5 Construction Assessment

### 9.5.1 Initial Impacts

During construction, waste would be generated during earthworks, construction of the fence, paths, road accesses and buildings, and connecting the power systems to the network. The main types of waste generated would be sand, gravel, concrete, asphalt, scrap steel, glass, plastic, wood, packaging materials and municipal waste from construction workers. Given the size of the facility, the amount of waste generated will be significant and if not properly managed will look unsightly, and may lead to contamination of the soils and groundwater.

#### Non-Hazardous Waste

During the construction phase, a number of activities will result in waste generation. These activities include, but are not limited to:

- Site clearance and levelling;
- Backfilling and excavation;
- Constructing a boundary wall and site offices;
- Power and water connections; and

- Temporary sewerage and drainage network construction.

The types of waste generated by these activities include:

- Sand;
- Gravel;
- Concrete;
- Asphalt paving;
- Scrap steel;
- Glass;
- Plastics;
- Packaging materials;
- Wood; and
- Municipal waste from construction workers.

Concrete may be found in two forms on the construction site; structural elements containing reinforced concrete, while foundations have mass non-reinforced concrete.

Construction waste is often bulky and heavy and mostly unsuitable for disposal by incineration or composting. Other than the hazardous waste fraction, which is discussed in the following section, construction material is mainly inert and does not pose a threat to human health or the environment. However, proper management is required in order to reduce associated secondary impacts such as resource use, dust emissions, and habitat destruction. Increased pressure may be placed upon local landfills and result in a reduced capacity for handling waste from municipal sources.

Prior to the implementation of mitigation measures, it is considered that the generation of non-hazardous waste during the construction phase will result in a temporary impact of moderate to major negative significance.

### **Hazardous Waste**

Although the hazardous fraction of construction waste represents a relatively small portion of the total amount of construction waste likely to be generated, its disposal requires careful consideration. Typical hazardous waste streams that may arise during construction include:

- Solvents;
- Used oil;
- Hydraulic fluid;
- Resins and paints;
- Batteries;
- Waterproofing compounds;

- Adhesives;
- Machinery lubricants;
- Waste chemicals - used in the concrete forming process;
- Clean-up materials (such as rags) contaminated with the items listed above;
- Drums, containers and tins with remains of hazardous substances.

The hazardous fraction of the construction waste can potentially cause significant adverse impacts on human health and the environment if managed improperly. Inappropriate handling through lack of personnel training on site may lead to accidental spills or leaks to the soil or groundwater may lead to a contamination event, resulting in a potential health risk to workers and environmental impacts. Contamination may also arise a result of transportation by waste contractors who have not been approved by MEMEE or disposal to unlicensed landfills. Increased pressure may be placed upon local hazardous waste landfills and result in a reduced capacity for handling waste from municipal sources.

Therefore, prior to the implementation of mitigation measures, it is expected that the hazardous waste generated during the construction phase of the Project will result in a temporary impact of moderate negative significance.

**Table 9-2 Solid Wastes - Magnitude of Construction Impacts**

Impact	Magnitude	Justification
Non Hazardous wastes	Moderate	Given the size of the project and material quantities, hazardous wastes will be generated and if not appropriately disposed or handled may result with contamination and increased pressure on local landfills.
Hazardous Wastes	Minor	Low volumes of non hazardous wastes will be generated, and if not appropriately disposed or handled may result with contamination and increased pressure on local landfills.

**Table 9-3 Solid Wastes - Significance of Construction Impacts**

Impact	Magnitude	Receptor	Sensitivity	Impact Significance
Non Hazardous wastes	Moderate	Land fill	High	Moderate to Major
		Soil and Groundwater	Medium	Moderate
Hazardous Wastes	Minor	Land fill	High	Minor to Moderate
		Soil and Groundwater	Medium	Minor

### 9.5.2 Mitigation Measures

The mitigation measures provided refer to both hazardous and non-hazardous wastes. Whilst some mitigation measures are specific to either hazardous or non-hazardous waste streams, many measures are applicable to both and therefore this section does not consider these measures separately, unless specified.

In order to minimise the impacts resulting from waste generation during the construction phase, the total amount of construction waste generated must be reduced to the greatest possible extent. The following mitigation measures will contribute to the reduction of overall waste generated by the Project:

#### Waste Management Plan

Prior to the start of construction activities, a CESMP will need to be prepared by the EPC. This is a requirement of the IFC Performance Standard 1 in determining an 'action plan' and management system. A site specific Waste Management Plan will need to be included as part of the CESMP.

In general, prevention can be achieved through proper planning with dedicated low-waste design, efficient material use involving careful selection, accurate ordering of materials, and effective process control. Reuse and recycling allows the recovery of usable components for subsequent use or for sale. Disposal of waste to landfills must be considered as the least preferable option and will only be resorted to for waste streams that cannot be recycled or reused. Practical examples of reduction or recycling opportunities, include the following:

- Waste concrete and masonry can be re-used in road construction and base fillings; reasonable levels of utilisation is 80 to 90%;
- The amount of waste timber generated can be reduced through ensuring accurate measurements and orders are placed, and re-use for general construction purposes. It is estimated that 50 to 60% of this waste stream can be recycled;
- Waste metal can readily be recycled, 100% of this waste stream can be eliminated;
- It is conservatively estimated that 80% of oils can be refurbished or reused through environmentally friendly energy recovery; and
- Ordering materials that have reusable packaging and/or in bulk can significantly reduce waste generated.
- Suppliers will be requested to use minimal packaging. Chemicals will be ordered in returnable drums. "Buy-back" arrangements will be made with key suppliers so that any surplus chemicals or materials can be returned;
- Refillable containers will be used, where possible, for collection of waste fluids such as waste oil, hydraulic oils, and used grease.

---

## Housekeeping

The construction waste management plan needs to establish good housekeeping practices to ensure that both hazardous and non hazardous waste fractions are separated, properly handled, stored and subsequently transported, recycled or disposed by an approved waste management contractor to a licensed landfill or alternative disposal location. Good housekeeping practices will be incorporated within the construction waste management plan, including the following:

- Separation of waste streams to facilitate recycling;
- Adequate storage facilities for non-hazardous waste storage in designated areas to prevent waste from dispersing throughout the site;
- Adequate hazardous waste storage in bunded containers stored in dedicated, covered storage areas with impermeable bases, sufficient containment capacity and equipped with spill kits;
- Immediate spill response protocol and contingency plans to detail the clean up of any spillages;
- Procedures and rules for hazardous waste handling;
- Mandatory training program for employees to increase their awareness of waste management protocols including proper handling and storage of waste, and emergency response and contingency plans.

## Waste Storage

The storage of waste will meet and comply with the following requirements:

- Food waste: Must be stored within a sealed metal or plastic skip or bin, in order to prevent vermin/pests gaining access;
- Lightweight waste e.g. paper, cardboard, plastics: Must be stored within a skip sealed with a secured tarpaulin/netting sufficient to prevent any material being dispersed;
- Heavy waste: To be contained within an open skip, providing that segregation occurs effectively enough to remove all lightweight material that could be blown away;
- Hazardous waste: Hazardous waste must be contained within impermeable containers with sufficient containment to prevent any spills. Storage containers will be bunded where necessary. The bunded base will have the capacity to contain 110% of the total volume of stored materials. This area must be placed away from any sources of ignition.
- Extinguishers (1 every 500 m<sup>2</sup>) must be placed in the most strategic points and preferably in the areas close to flammable/combustible leftover storage area.

- The storage shed will be built over a concrete pad to protect the stored waste from stormwater run off.
- Storage sheds will also have a built in drainage system to contain any spills or leaks and facilitate safe removal.

All storage areas must be well organised and waste appropriately managed through segregation of hazardous and non-hazardous waste. Waste within each category will be further segregated by type (paper, plastic, metal) and whether the material is recyclable or non-recyclable. Construction waste will be separated into combustible and non-combustible, and all flammable substances must be kept away from sources of ignition.

For litter (food waste, domestic waste), an adequate number of bins will be placed throughout the site at locations where construction workers and staff consume food. These will be regularly collected and taken to the main waste storage area. On-going housekeeping training will be provided to all staff on the importance of the need to avoid littering.

- Waste containers will be clearly marked with appropriate warning labels to accurately describe their contents and detailed safety precautions. Labels will be waterproof, securely attached, and written in French and Arabic. Wherever possible, chemicals will be kept in their original container;
- Waste generated during construction will only be transported off-site for disposal by an appropriately licensed vendor. This contractor will follow the proper protocols to ensure that all waste handling and disposal from the site is carried out according to accepted environmental regulations. A record for all streams of generated waste will be kept onsite by EPC. This will be readily available for review by the concerned authority; and
- Regular training of site personnel in proper waste management and chemical handling procedures will be conducted at regular intervals.

### **Hazardous Waste**

Impacts associated with hazardous waste can also be effectively mitigated through the implementation of best practice and regulations. Specifically, this involves the implementation of procedures for adequate handling, establishment of secure temporary storage areas, and disposal of waste by approved contractors. These measures, if implemented correctly, will prove sufficient to prevent contamination of soil and groundwater and associated secondary impacts. The EPC, sub contractors will be required to ensure the proper handling, storage and disposal of hazardous waste, according to best environmental practices and guidelines.



### 9.5.3 Residual Impacts

Following the implementation of the mitigation measures detailed above and through effective implementation of the measures and protocols set out within the Waste Management Plan, the potential residual impacts of waste generated during the construction phase are likely to be negligible in significance.

**Table 9-4 Solid Waste– Residual Impacts – Construction Phase**

Impact	Magnitude	Receptor	Sensitivity	Impact Significance	Mitigation	Residual Impact Significance
Non Hazardous wastes	Moderate	Land fill	High	Moderate to Major	Yes	Moderate
		Soil and Groundwater	Medium	Moderate	Yes	Minor
Hazardous Wastes	Minor	Land fill	High	Minor to Moderate	Yes	Minor
		Soil and Groundwater	Medium	Minor	Yes	Negligible

## 9.6 Operation Assessment

### 9.6.1 Initial Impacts

Solid wastes will be generated at several facilities within the power block. Some of these will be direct products resulting from the operation and maintenance of the facilities, whilst other wastes will be the byproducts of primary waste treatment processes, for example the sludge that results from wastewater treatment.

In addition to solid waste generation from the CSP plant, the operation of the proposed Project will generate domestic waste from the operation of the administration and canteen facilities. This waste can be classified as both recyclable and non-recyclable. Recyclable waste includes paper, tin cans, plastics, cartons, rubber, and glass, while non-recyclables will consist mainly of food residues and other organic waste.

#### Industrial Non-Hazardous Waste

Industrial non-hazardous waste refers to waste generated by operation activities that do not exhibit any characteristics, which can potentially harm human health or the environment. This type of waste can be classified further as recyclable and non-recyclable. Industrial non-hazardous waste generated during the operation of the NOORo II CSP may include empty containers, general clean-up materials, packaging materials resulting from general, manufacturing or laboratory operations, and inert insoluble solid materials such as glass, rubber, and plastics. Sewage sludge produced may contain high levels of bacteria, nitrates

and salts that can result in water contamination and can cause disease, such as hepatitis A or E. coli, if ingested. If the sludge is not properly disposed, contamination and health risks are likely.

### **Industrial Hazardous Waste**

This fraction of waste streams generated can potentially cause significant adverse impacts on human health and the environment if managed improperly.

Examples of likely hazardous waste streams that may arise during the operation of the Project include the following:

- Sludge from the various waste water and waste oil treatment processes;
- Heavy metals within the sludge;
- Waste oil, oily sludge, oily rags, chemicals, solvents from general maintenance of on-site plant and machinery;
- Used chemical and fuel drums;
- Used filter mediums;
- Soil contaminated by potential spills and leaks;
- Miscellaneous wastes such as batteries, wire cables, and
- General clean-up materials.

Hazardous waste streams generated during the operation and maintenance of the plant and machinery onsite represent the potential to be released into the environment. This subsequently represents a potential impact upon soil, in terms of contamination events. Potential sources, contamination pathways and appropriate mitigation measures are addressed within Chapter 5: Soil Contamination.

Inappropriate handling through lack of personnel training on site may lead to accidental spills or leaks to the soil which leads to a contamination event, resulting in a potential health risk to workers and environmental impacts. Contamination may also arise as a result of transportation by waste contractors who have not been approved by the regulator or disposal to unlicensed landfills. Increased pressure may be placed upon local hazardous waste landfills and result in a reduced capacity for handling waste from municipal sources.

The evaporation residuals will be accumulated in the pond as long as the water evaporates and they get concentrated. In this phase, it is not possible to estimate a quantity because the operation of the system has to consider also wind blown dust/sand influence, but as the effluents have been treated previously (removal of oil and solid particles), the amount of residuals is expected to be insignificant. In any case, the system is designed to allow the removal of solids from one pond without stopping the plant, using the other pond. The pond will be empty only during short maintenance operation to evacuate solids, additionally the

small percentage of oily /greasy substances in contact with the dust or sand become a solid substance which means it is not possible for wind to mobilize residuals containing hazardous substances.

The following table summarises the types of wastes, which will be generated.

**Table 9-5 Wastes Streams and Estimated Quantities**

Plant	Waste	Quantities
Raw Water Treatment Plant	Activated Carbon	3,240Kg/5yrs
	Sand	43,212 Kg/5yrs
	Anthracite	44,607 Kg/5yrs
	Filtration Cartridge	1,310 cartridges/5yrs
	R/O Membranes	198membreane/5yrs
	EDI Module	1 module/5yrs
Effluents Treatment Plant	Sludge	3,500Kg wet sludge/h
Oil water separator	Sludge	120kg wet sludge/h
HTF Separator	Sludge	160kg wet sludge/h
Sanitary Treatment	Sludge	5kg wet sludge/h
Industrial Maintenance	Scrap metal, glass, plastics, tires etc	30 Tons/year
Office wastes	Paper, plastics, putrescible etc	10 Tons/year
Health Clinic	Medications, syringes, gloves, gauzes	20Kg/year

(\*) The quantities given in this document are an average estimation; they will depend on the oils drainages/spillages, rainfall intensity, quality of raw water, etc.

**Table 9-6 Solid Wastes - Magnitude of Operation Impacts**

Impact	Magnitude	Justification
Non Hazardous wastes	Minor	The low number of staff employed at the site and type of daily activities will only generate small volumes of waste.
Hazardous Wastes	Minor	The CSP plant will generate small quantities of hazardous wastes calculated over years of accumulation, with the exception of sludge. The reduction of water usage for the cooling system will also decrease the volume of sludge produced.

**Table 9-7 Solid Wastes - Significance of Operation Impacts**

Impact	Magnitude	Receptor	Sensitivity	Impact Significance
Non Hazardous wastes	Minor	Land fill	High	Minor to Moderate
		Soil and Groundwater	Medium	Minor
Hazardous Wastes	Minor	Land fill	High	Minor to Moderate
		Soil and Groundwater	Medium	Minor

### 9.6.2 Mitigation Measures

Suitable implementation of controls and procedures for handling, storage, transport and disposal of waste can prevent the generation of significant amounts of waste during operation. It is recommended that prevention or reduction at source, followed by reuse and recycling methods must be implemented on site to reduce the residual impacts of waste generated as a result of the Project. Adherence to guidance and recommendations set out by national and IFC/World Bank standards will form the basis of the mitigation measures prescribed in this section.

These measures will be fully described within, and implemented through a detailed site specific Waste Management Plan within the Operation Environmental and Social Management Plan (OESMP) developed for the proposed Project O&M. The mitigation measures presented will be cross-referenced within the Waste Management Plan and focus predominantly on the appropriate handling, storage, segregation, transport, and disposal of all waste. The following mitigation measures are applicable during the operational phase:

- A bioremediation tank will be built on site to process soil contaminated by HTF.
- Segregation and storage of different types of waste in separate labelled containers, to promote the re-use and/or recycling of materials;
- Use high quality raw material to reduce the quantities of waste generated;
- Reduce packaging of materials and order in bulk. If appropriate, request supplier to minimise packaging;
- Recycle paper, metal, plastic and packaging;
- Implement a recording system for the amount of wastes generated on-site;
- Undertake regular inspections, audits, and monitoring of waste streams generated to ensure that all necessary mitigation measures are being implemented;
- Waste solvents, oils and other hazardous materials used at the site will be collected in suitably banded and protected areas.
- Hazardous waste will be collected and transported by appropriately licensed transporters to approved hazardous waste disposal sites when re-use is not an option;
- Consignment details and records of the hazardous waste generated shall be maintained in the facility;
- Waste disposal records and details of disposal locations will be maintained and kept on site to ensure that all waste streams (non-hazardous and hazardous) are disposed in an appropriate way;
- Only trained personnel will be permitted to handle hazardous waste;

- Implementation of spillage and leakage prevention measures such as a development of manuals for proper waste handling, regular inspection of containers and storage areas;
- General household and domestic waste generated by Project staff will be stored in area clearly marked. Separate colour coded and labelled waste bins will be installed at different locations throughout the Project site;
- Mandatory training program for employees to increase awareness of waste management including proper waste; Training and orientation on waste minimisation, segregation and proper good housekeeping practice at the beginning of work and at regular interval will be conducted.

### 9.6.3 Residual Impacts

Following the implementation of the mitigation measures detailed above, it is predicted that the residual impacts of the Project upon the local waste infrastructure, landfill capacities and human health and the environment are likely to be of minor to negligible negative significance.

**Table 9-8 Solid Waste– Residual Impacts – Operation Phase**

Impact	Magnitude	Receptor	Sensitivity	Impact Significance	Mitigation	Residual Impact Significance
Non Hazardous wastes	Minor	Land fill	High	Minor to Moderate	Yes	Minor
		Soil and Groundwater	Medium	Minor	Yes	Negligible
Hazardous Wastes	Minor	Land fill	High	Minor to Moderate	Yes	Minor
		Soil and Groundwater	Medium	Minor	Yes	Negligible

## 10 STORMWATER MANAGEMENT

### 10.1 Introduction

Chapter 6 discussed water use and wastewater management for project activities. This chapter discusses the potentials risks for soil erosion and flooding and assesses the potential impacts resulting from changes in the topography and soil conditions of the site.

Currently, several Chaabas, ephemeral streams small erosion ditches have naturally formed as a result of the precipitation, topography, minimal vegetation and soil characteristics.

Infrequent heavy rain events, also results with increased erosion and the sediment laden runoff discharges to the Mansour Ed Dahbi Reservoir.

The development of the project will change the topography and soil characteristics of the site. Also, two channels that currently run through the site will be diverted. These changes will result with new storm water runoff pattern, which can potentially lead to increased erosion and flood risks downstream.

## **10.2 Methodology**

The assessment has been conducted by identifying the relevant local and international standards and best practice applicable to the environmental conditions at the NOORo II site relating to storm water management and erosion prevention during the construction and operational phases of the proposed facility. Estimates and figures relating to storm water volumes and proposed treatment processes have been based on the data available from hydrological study of the FESIA and the data provided in the bid proposal.

## **10.3 Baseline**

The site is currently a greenfield, therefore the existing drainage channels consists of three (3) Chaabas crossing the site from north to south, which pass trough the sites of NOORo 1 and NOORo III. Another three (3) Chaabas, start within the NOORo II site and flow south into the NOORo 1 site.

Given the development of NOORo 1, the drainage of some three of these Chaabas has been diverted to man made stormwater collection systems. Equally, MASEN is developing a primary stormwater diversion system, running east/west between the boundaries of the three proposed solar power plant sites, so as to capture all stormwater and divert it to the main canyon to the east of the sites, towards Oued Izerki. Once the installation of this system is completed, all secondary stormwater systems from the three plants will be diverted to this main stormwater system. Consequently all stormwater will be combined and discharged to the eastern canyon leading to the reservoir.

The current layout of the Chaabas and depiction of the MASEN stormwater is mapped in the figure below. The catchment area and the maximum discharge for a 50, 100 and 500 year period is also specified in the below table.

The catchment areas refer to the extent of land where water from precipitation runs to each chaaba. The hydrological study undertaken for the FESIA determined that there are currently no flooding risks on site, as all the stormwater that falls on the plateau is channelled through the chaabas to the surrounding canyons.



**Table 10-1 Onsite water courses catchment area (m3/s)**

	<b>2years</b>	<b>5years</b>	<b>10years</b>	<b>20years</b>	<b>50years</b>	<b>100years</b>
<b>A</b>	2,184	4,162	5,462	6,683	8,285	9,462
<b>B</b>	1,539	2,925	3,836	4,693	5,816	6,642
<b>C</b>	1,744	3,342	4,391	5,376	6,667	7,616
<b>D</b>	2,008	3,890	5,124	6,280	7,797	8,909
<b>E</b>	1,245	2,360	3,094	3,785	4,689	5,354
<b>F</b>	1,172	2,215	2,901	3,548	4,394	5,017
<b>G</b>	0,531	0,973	1,266	1,544	1,907	2,175
<b>H</b>	0,385	0,711	0,927	1,131	1,399	1,596
<b>I</b>	0,142	0,263	0,344	0,420	0,519	0,592

Plate 10-1 Chaabas and Catchments within the Site

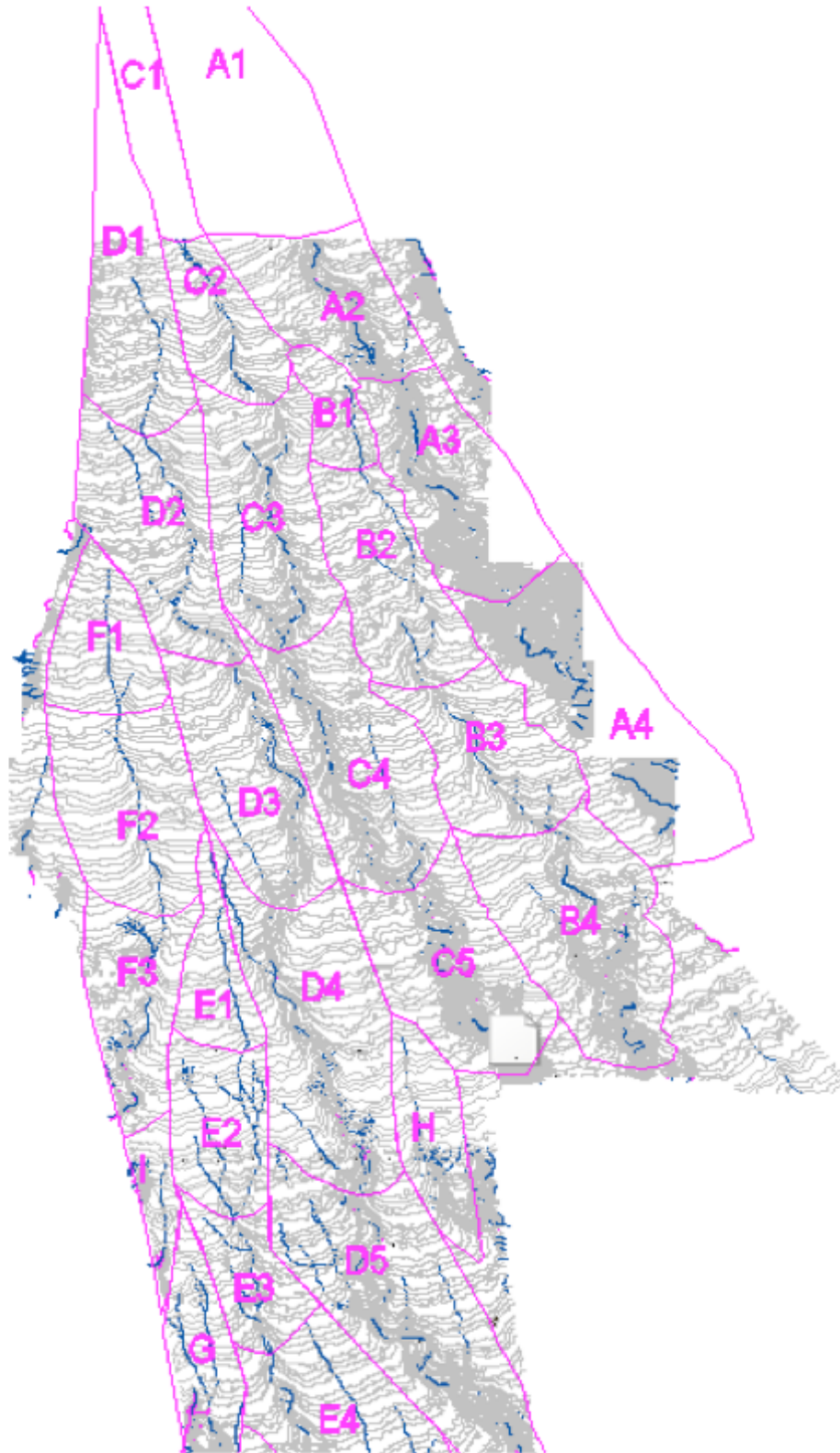

1

According to the FESIA, the project site was characterised at a high risk for erosion. Across the majority of the NOORo 1, 2, & 3 Solar Complex sites, the level of erosion risk has been classified between 5 and 10 t/ha/year. This high risk of erosion is due to the following factors:

- Intensity of rainfall;
- Soil type;
- Sparse vegetation cover;
- Topography and the slope.

Furthermore, upstream erosion results with increased sediment load in the water streams, which adversely affects the Mansour Ed Dahbi reservoir and irrigation for agriculture downstream.

With regards to flood risk, the site is an elevated plateau and the Chaabas collect and drain all stormwater to the lower canyons, consequently, flood risk is not currently an issue. However, any major changes in the drainage regime and drainage patterns, from the site to the canyons, could result with downstream flooding.

#### 10.4 Sensitive Receptors

The table below outlines the identified receptors in relation to geology and hydrogeology as well as the determined sensitivity of those receptors.

**Table 10-2 Stormwater - Receptor Sensitivity**

Receptor	Sensitivity	Justification
Soil/Geology	Medium	The project will modify the current topography and soil characteristics at the site.
Canyons and Oueds	Low	The canyons are the major catchments for all stormwater running off the plateaus.
Irrigation Farms	Medium	Changes in the drainage regime and flow from stormwater events will affect the volume, and quality of irrigation water.
Mansour Ed Dahbi reservoir	Medium	Changes in the drainage system and soil conditions may increase silt in the stormwater which discharges to the reservoir.

#### 10.5 Construction Assessment

##### 10.5.1 Initial Impacts

During construction the main environmental issue with stormwater relates to its potential contamination from wastewater spills or contaminated soils. This impact was already addressed in chapter 6.

The earthworks on site will disturb natural drainage patterns, potentially increasing erosion on site and within the canyons. However, given that the erosion potential onsite is naturally high and that the vegetation to be removed during the earthworks does not offer any significant protection against soil erosion, the increased erosion risk caused by earthworks during construction can be assessed as being of minor negative impact prior to mitigation.

The changes in the soil characteristics and increased earthworks activity, may result with increased siltation in the stormwater, however, given the construction activities will be temporary and most soils will be compacted, the risk for increased silt will be temporary and infrequent.

Flooding on the plateau is not an issue, and is unlikely to change as a result of construction activities. However, the diversion of the natural stormwater catchment system, may funnel the stormwater into one discharge point, which could result with localised flooding. Such events would be infrequent and short duration.

**Table 10-3 Stormwater – Magnitude of Construction Impacts**

Impact	Magnitude	Justification
Erosion	Minor	Construction is temporary; the site already experiences natural erosion from precipitation.
Flooding	Minor	Infrequent and short duration rain events may result in minor flooding events in localised areas.
Siltation	Minor	Construction will temporarily disturb soils, and during a storm event these will be more likely to become suspended.

**Table 10-4 Stormwater – Significance of Construction Impacts**

Impact	Magnitude	Receptor	Sensitivity	Impact Significance
Erosion	Minor	Soil/Geology	Medium	Minor
		Canyons and Oueds	Low	Negligible to Minor
Flooding	Minor	Canyons and Oueds	Low	Negligible to Minor
Siltation	Minor	Irrigation Farm	Medium	Minor
		Mansour Ed Dahbi Reservoir	Medium	Minor

### 10.5.2 Mitigation Measures

In order to reduce soil erosion during construction, the following measures will be undertaken:

- The site will be fenced to ensure that no soil disturbance occurs outside of the site area. The areas requiring excavation/filling shall be clearly demarcated to ensure that the soil is no disturbed outside that area;
- The chaabas coming from the north of the site will be channelled to the side canyons to avoid intense runoff through the site during the earthworks.
- Access roads and routes gradients should not exceed 15%
- Adapting existing topography where practicable so as to facilitate surface drainage by way of gutters.
- The longitudinal slope of the road must be at least 3% in order to facilitate surface run-off of water and to avoid the build up of sediment in gutters
- Reduce height of embankments and slopes
- Recover vegetation on slopes and embankments
- Perform land cross sections in the most stable areas, taking into consideration the geological conditions of lands.
- Avoid steep gradients on lands susceptible to landslides.
- Construct gabions and concrete barriers for containment, use metal mesh and nets, drains and gutters in slopes for terrain stability
- From the outset of work, plan, select and define areas for clearing, stripping and access routes in order to minimise unnecessary stripping of vegetation.
- Reduce cut-offs and embankments.

### 10.5.3 Residual Impacts

**Table 10-5 Stormwater – Residual Impacts – Construction Phase**

Impact	Magnitude	Receptor	Sensitivity	Impact Significance	Mitigation	Residual Impact Significance
Erosion	Minor	Soil/Geology	Medium	Minor	Yes	Negligible
		Canyons and Oueds	Low	Negligible to Minor	Yes	Negligible
Flooding	Minor	Canyons and Oueds	Low	Negligible to Minor	Yes	Negligible
Siltation	Minor	Irrigation Farm	Medium	Minor	Yes	Negligible
		Mansour Ed Dahbi Reservoir	Medium	Minor	Yes	Negligible

## 10.6 Operation Assessment

### 10.6.1 Initial Impacts

#### Project storm water management

The drainage system on site is designed in such a way that rainfall into the areas where there could be oil or HTF contamination would be collected and treated in oily water separation systems. As described in chapter 6, waters potentially polluted by hydrocarbons and HTF will be treated and discharged to the evaporation ponds.

The water flowing from the north of the site through the Chaabas will be collected by a concrete channel at the north of the site, and discharged to the canyons to the West of the site. The channel will be designed to evacuate an estimated 3,01 m<sup>3</sup>/s of stormwater to the eastern canyon. The origin of these waters would be from the northern landscape strip.

The rest of the rainwater falling on the site will be channelled through pipes and concrete ditches to a channel built to the south of the site. The channel will be designed to evacuate an estimated 17.04 m<sup>3</sup>/s of stormwater to the eastern canyon.

#### Plate 10-2 North and South Channel Discharge Point

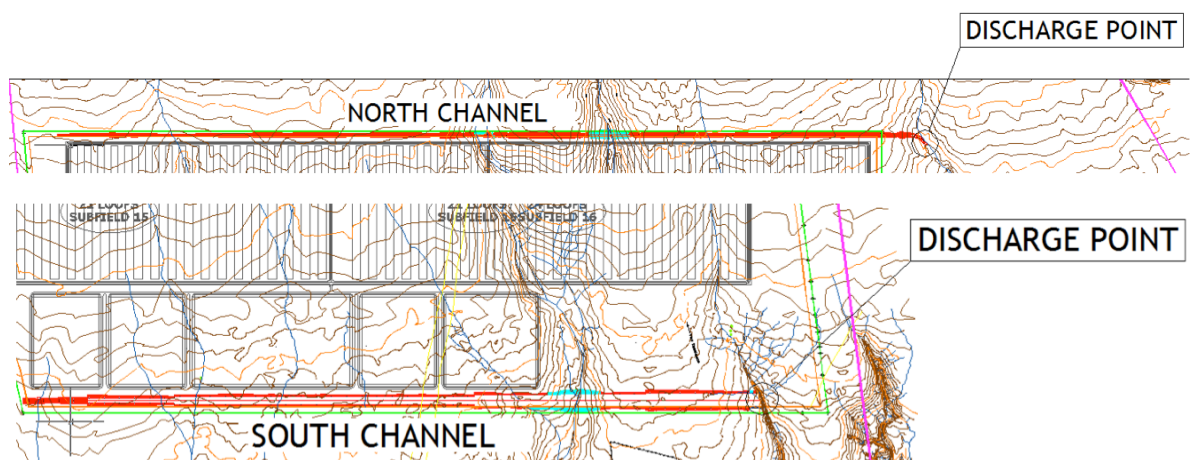

The discharge points of the drainage system will be protected by means of stone rubbles, placed at the appropriate dumping angle. A zone will be protected against erosion at each discharge point, before it comes into contact with the natural watercourse. The erosion protection design will consist of at least 5 meters of breakwater protection over a gravel bed, separated from natural soil with a geotextile layer. The size of rock and height of gravel will be selected according to water flow energy.

The potential contamination of rainwater, considering the design of the drainage system and prior to the implementation of further mitigation measures could result with minor negative impacts to the receiving environment.



The levelling of the site, the impermeable concrete areas and the channelling of storm water will lead to increase runoff velocities. The design of the project, including erosion barriers at discharge points, but prior to mitigation measures, could lead to a minor negative impact on erosion rates on the canyons around the site.

**Table 10-6 Stormwater – Magnitude of Operation Impacts**

Impact	Magnitude	Justification
Erosion	Minor	On site, soils will be compacted. Off site, erosion will occur where run-off is directed to unpaved, unvegetated or unprotected areas.
Flooding	Minor	Negligible issue on site. Flooding in the canyon may be localised, infrequent and short duration.
Stormwater Contamination	Minor	Any stormwater that comes into contact with contaminated soils, or flows into equipment rooms or overflow of the oil water separator may result with contamination of the stormwater.
Siltation	Minor	During storm events, any run-off on unconsolidated soils will result with some siltation. Events will be infrequent and of short duration.

**Table 10-7 Stormwater – Significance of Operation Impacts**

Impact	Magnitude	Receptor	Sensitivity	Impact Significance
Erosion	Minor	Soil/Geology	Medium	Minor
		Canyons and Oueds	Low	Negligible to Minor
Flooding	Minor	Canyons and Oueds	Low	Negligible to Minor
Stormwater Contamination	Minor	Soil/Geology	Medium	Minor
Siltation	Minor	Irrigation Farm	Medium	Minor
		Mansour Ed Dahbi Reservoir	Medium	Minor

### 10.6.2 Mitigation Measures

- The site needs to be inspected regularly to ensure that no HTF or oil spills (or any other spills that can contaminate rainwater) occur outside the areas designated for storm water collection and treatment.
- Wastewater collection systems and oil water separators should be inspected frequently, to ensure that no blockages could result with overflowing.
- Waste management areas have to be designed in such a way that rainwater is not in contact at any point with the waste.

- The effectiveness of erosion prevention mitigation measures at rainwater discharge points needs to be checked after storm events to check that the extend of the protection measures is sufficient, and those would be expanded if necessary.
- A re-vegetation programme on the slopes, embankments and on the canyons where wastewater will be discharged shall be undertaken to reduce soil erosion. Only native species of shrubs and trees adequate to the area shall be used.

### 10.6.3 Residual Impacts

**Table 10-8 Stormwater – Residual Impacts – Operation Phase**

Impact	Magnitude	Receptor	Sensitivity	Impact Significance	Mitigation	Residual Impact Significance
Erosion	Minor	Soil/Geology	Medium	Minor	Yes	Negligible
		Canyons and Oueds	Low	Negligible to Minor	Yes	Negligible
Flooding	Minor	Canyons and Oueds	Low	Negligible to Minor	Yes	Negligible
Stormwater Contamination	Minor	Soil/Geology	Medium	Minor	Yes	Negligible
Siltation	Minor	Irrigation Farm	Medium	Minor	Yes	Negligible
		Mansour Ed Dahbi Reservoir	Medium	Minor	Yes	Negligible

### 10.6.4 Summary and Recommendations

Provisions for the containment of the first flush of storm water in areas where there is a potential for HTF or oil spills should be considered in the project design, and this water should be adequately treated.

The provision for flood risk management and the impact that it may have downstream (including soil erosion, impact on habitats, and risk to human receptors) must be considered in the design of the CSP plant in reference to the chaabas and canyons that have been identified on and around the site.

## 11 ECOLOGY AND BIODIVERSITY

### 11.1 Introduction

This chapter considers the potential impacts on biodiversity that may occur during both the construction and operational phases of the Project. Where appropriate, mitigation measures

are proposed in order to minimise or negate the negative impacts and promote positive impacts, where possible.

Although the Project site is considered to be of relatively low ecological value, due to the sparse vegetation over the open plateau and limited habitat diversity, it is prudent to confirm the habitat types present and species composition.

Several nationally protected areas have been identified within a 15Km radius of the site. These include:

- The Biosphere Reserve of the South Moroccan Oasis
- Mansour Ed Dhabbi Dam. The dam's lake is part of a RAMSAR site and is located 6Km south of the southern limit of the proposed project.
- The Dorcas Gazelle Reserve of Bouljir. A 30ha reserve is located approximately 13Kmnorth west of the site.
- The Iguenane Reserve was designated in 2005, under the framework of the 'Projet de Conservation de la Biodiversite par la Transhumance' for its high biodiversity of endemic flora and high diversity of fauna. The reserve is located approximately 15Km northwest of the site.
- Sbaa Chaab, recognised under the framework of the 'Projet de Conservation de la Biodiversite par la Transhumance' as a key biodiversity site as it represents one of the best protected sites in the region.

The project will not have an impact on the Dorcas Gazelle Reserve of Bouljir, the Iguenane Reserve or Sbaa Chaab site, as these are far from the project site. However, the project is located within the Biosphere Reserve of the South Moroccan Oasis and extracts water directly from the Mansour Ed Dhabbi Dam, so potential impacts on these protected areas are further discussed in this chapter.

## 11.2 Methodology

In order to gain an understanding of the terrestrial ecology of the Project Site and the biodiversity sensitive areas in the region, a combination of desk studies and field survey was undertaken.

Desk studies for the area included reviewing ecological survey data from the FESIA, literature review of habitats and fauna of the South Atlas Region, and verification on the IUCN Red list of any vulnerable and near threatened species that may have been recorded in the region.

The ecological section of the FESIA report provided the results of detailed 3-day survey campaign, which was carried out by Phénixa in 2010. Although this survey covered an area of 5,376Ha, which consisted of the entire 2020 Concept Solar Power Complex site and a 1Km

periphery, the results are representative of the typical and likely fauna, flora and habitats which are encountered at the NOORo II project site.

Consequently, the objective of the second survey undertaken in May 2014, with the guidance of MASEN, was to review and confirm the ecological conditions of the NOORo II site with respect to the observations recorded during the 2010 survey. This walkover survey therefore, consisted of a rapid ecological assessment of the 450Ha of the NOORo II CSP site. The site was covered by vehicle, and the majority of identified habitats were then more closely investigated on foot. The following methods were utilised to describe and assess the habitats, flora and fauna of the site:

- The vegetation of the site was recorded by identifying the main habitat types and their plant communities in areas retaining natural vegetation.
- Mammals were recorded when observed, as were their tracks. Reptiles were surveyed by walking over areas representative of the main habitats. An effort was made to search for reptiles under natural shelters such as shrubs and crevices. Bird sightings and incidental observations of invertebrates were recorded. No trapping or specimen collection was undertaken.

### 11.3 Baseline

#### 11.3.1 Project Site

The 2010 survey described three distinct habitat types based on the geomorphology of the site:

- Rocky Plateau: which typically support a low biomass and limited biodiversity.
- Small Chaabas within the site and larger Chaabas on the periphery;
- Escarpments formed between the plateaus and the bases of the Chaabas.

Within the Rocky Plateau, three ecotypes were identified based on the soil composition and surface water drainage patterns. The rocky and hard substrate sections of the plateau supported the least biomass and biodiversity which was sparsely populated with succulent species of the family *Chenopodiaceae*. Conversely, within the alluvial plains and minor slopes of the drainage patterns, a relatively greater concentration and diversity of flora was observed.

Within the escarpments, the level of biomass and biodiversity was relatively high, particularly in areas where water could temporarily pool or along the edges of the drainage patterns.

Finally, the Chaabas offered varying degrees of biomass and biodiversity depending on the size of the Chaabas bed and the frequency and volume of water running through the system. The larger Chaabas, which would have received flash flows of water from the High

Atlas would typically have a lower biomass than the smaller Chaabas which experienced a more tempered water flow regime.

In general, the small Chaabas provided the greatest biomass and sustained the greatest diversity of flora. This is not surprising as the soil conditions and water regime would favour the successful and longterm establishment of a diversity of vegetation.

The observations from the May 2014, revealed no changes to the ecological character of the site. No new habitats had been created, nor any of the existing habitats appeared to have altered. In effect the construction activities from the NOORo 1 CSP plant had not resulted with any noticeable changes to the ecological setting at the NOORo II site.

### **Flora**

The main habitat type identified within the survey area, and based on geomorphology and plant communities is Rocky Plateau. This habitat type is characterised by cobble, rock and consolidated fine gravels with sparse vegetation, typically consisting of arid tolerant shrubs, succulents, parasitic plants and occasional grasses.

Overall, 67 species of vegetation were identified across the entire +5,000 ha survey. However, only 4 species were endemic to the rocky plateau of the study region of South Morocco. It must be noted that such a limited endemic diversity is characteristic of the greater subsaharan plains.

None of the observed species are listed as rare or vulnerable regionally or on the IUCN red list.

A table summarising the species observed during the 2010 survey is provided in Appendix 2.

During the Rapid Ecological Assessment of the Project Site, low-lying halophytic vegetation was identified as the predominant flora across the majority of the proposed site, which indicates a highly saline and arid environment. The vegetation cover at the Project Site was <1% and did not contain any notable species, with the exception of *Ziziphus lotus*, a type of shrub attaining heights of 0.5 and 2m, and commonly grazed upon by goats and camels. Also, the fruits of the shrub may be consumed by the local residents or traditionally used for medicinal treatment, and the flowers are an important source of pollen for bees. These shrubs also play an important role in the fight against desertification, as the root system helps to consolidate the soils and sands. The density and distribution of the shrub has been negatively affected by exploitation from the nomads and livestock.

### **Fauna**

The presence of herptafauna, avifauna and mammals was investigated. Given the local geology and presence of water bodies the diversity of amphibians and reptiles would be

high. Historically the region is known to support over 17 species of reptiles and amphibians, four of these being endemic to the Maghreb: the Mauritanian Toad, North African Green Frog, Oudri Gecko and the Saharan Spiny Tailed Lizard, which is listed as Near Threatened on the IUCN red list. No species of reptiles were observed on the plateau or along the Chaabas during the May 2014 walkover survey.

The presence and diversity of mammals on the other hand is not well supported on the site. Several species have not been recorded in the area since the 1960's and these include: The Dorcas Gazelle, Cuvier's Gazelle, Striped Hyena and Crested Porcupine. The Gazelles were likely hunted to local extinction.

Evidence of the Red Fox (within Chaaba Izerki) and unidentified bats were the only observations of mammals on the site.

A summary of the mammals recorded and historically resident is also given in Appendix 2.

The varieties of birds observed during the site visit, comprised of resident and migratory species. Of the 10 resident species observed, the Morning Wheatear is rare and localised in Morocco. Only 9 migratory species were observed at the time of the 2010 survey, however it should be noted, that this sector is not considered a major migratory pathway, which is mostly limited to the Southern parts of the High Atlas.

With regards to the typical Saharan resident species not observed, but which would be expected to reside in the surrounding areas, the absence of their sighting is likely due to local foraging movements within more favourable habitats.

A summary of the birds recorded and likely resident is given in Appendix 2.

During the field visit of May 2014, given the time of year and limited presence on site, no major fauna were observed. Goat droppings were the only signs of large fauna crossing the area, and small burrows within the root systems of the vegetation provided evidence of small mammals and reptilian species occupying the site.



**Plate 11-1 Typical site ecological conditions**



**Plate 11-2 Vegetation grouped in the Chaabas channel**





**Plate 11-3 Small mammal or reptile burrow****11.3.2 The South Moroccan Oasis Biosphere Reserve**

The project is located within the Oasis De Sud Marocain Biosphere Reserve. The habitat landscape of this biosphere reserve consists mainly of temperate grasslands, highland systems, desert areas (both semi-desert and warm-desert) and various mountain systems. The agricultural areas provide grazing but are mostly used for the cultivation of olives, cereals, dates and potatoes. Most of the habitats within this national reserve in Morocco are made up of Acacia forests, cliffs, lakes, mountain lakes, palm oases, sand dunes and desert steppes. This biosphere reserve is considered key in the fight against desertification and it is dedicated to the research and awareness of the correct use of water systems, freshwater systems and ecosystems.

The project site will be located within Zone B of the South Moroccan Oasis Biosphere Reserve. According to its framework management plan, this area is defined as a "buffer zone" with the objective of only permitting developments that are compatible with conservation principles. The plan acknowledges the need for energy generation and favours renewable energy, so the solar plant is considered to comply with the management plan. The biosphere

reserve is 72.000 km<sup>2</sup>, and the project site will occupy 6.8 km<sup>2</sup>, adjacent to the existing NOORo 1 facility.

### **11.3.3 Mansour Ad-Dhabi reservoir**

The reservoir is located approximately 6km south of the site. Water for the entire solar power complex will be drawn from the reservoir. The reservoir is part of a RAMSAR site, a Site of Biological and Ecological Importance (SIBE) and an Important Bird Area (IBA).

#### **RAMSAR site**

The RAMSAR site Moyenne Dr'a (site no. 1482) is composed of six units within two artificial habitats: the reservoir of the Al Mansour Ad-Dahbi dam and six oases with irrigated palm plantations along the course of the Dr'a River. More than 20 bird species winter or nest in the area of the dam, while about 100 other bird species rely on the oases' palm plantations.

#### **Site of Biological and Ecological Importance**

The reservoir is a priority 2 Site of Biological and Ecological Importance (SIBE no. H42). The SIBE network was established in the frame of "The Study of Protected Areas of Morocco"(AEFCS, BCEOM - SECA, 1995) which had as an objective the elaboration of a network that regroups all the representative sites on the bioecological plan of zones with the index of high biodiversity, or with a high concentration of vegetable or animal species, endemic, rare or endangered, and identify the zones of priority action at the heart of this network. A network of 160 SIBEs was created, grouped in 3 priority categories: priority 1 (48 SIBEs), priority 2 (50 SIBEs) and priority 3 (62 SIBEs). The priority n°1 are the most representative and the richest in biodiversity, and according to the "The Study of Protected Areas of Morocco" must be placed under a status of protection (natural reserve type) in a delay not above 5 years. The SIBE of priority 2 and 3 should have been placed under a status of protection in no more than 10 years.

#### **Important Bird Area (IBA)**

The reservoir is considered an Important Bird Area (IBA) by Birdlife International (code MA034).

#### **Ecology and bird population**

The IBA factsheet (2001) provides information about the reservoir. It states that where rivers and streams enter the lake, the water is relatively shallow and dense vegetation of *Cynodon dactylon*, *Cyperus spp.*, *Juncus spp.*, *Phragmites australis* and *Tamarix canariensis* occur. Elsewhere, the water depth drops off sharply, reaching 2–4 m deep only several metres from the rocky shore. According to the available information, the site is chiefly notable for its populations of summer visitors, such as *Marmaronetta angustirostris* and *Tadorna ferruginea*,



both of which exceed IBA thresholds. A few pairs of *Marmaronetta angustirostris* have bred onsite and *Tadorna ferruginea* breeds regularly, but numbers of pairs are unknown. Wintering populations of waterfowl are small, although some 20 species have been recorded. The most abundant is *Tadorna ferruginea*, with up to 400 individuals noted.

The Marbled Teal, identified as vulnerable, is the species of a highest concern on the reservoir according to the IUCN Red List. For this species, the wetlands marked in the figure below have been identified as important in North Africa and the Middle East.

**Figure 11-1 Wetlands identified as important for the Marbled Teal in N.Africa and the Middle East**



Focusing on the West African populations, the areas where it is native all year and the breeding areas are generally coastal areas. The reservoir is classified as a non-breeding passage area.

**Figure 11-2 Classification of wetlands identified as important for the Marbled Teal in N.Africa**

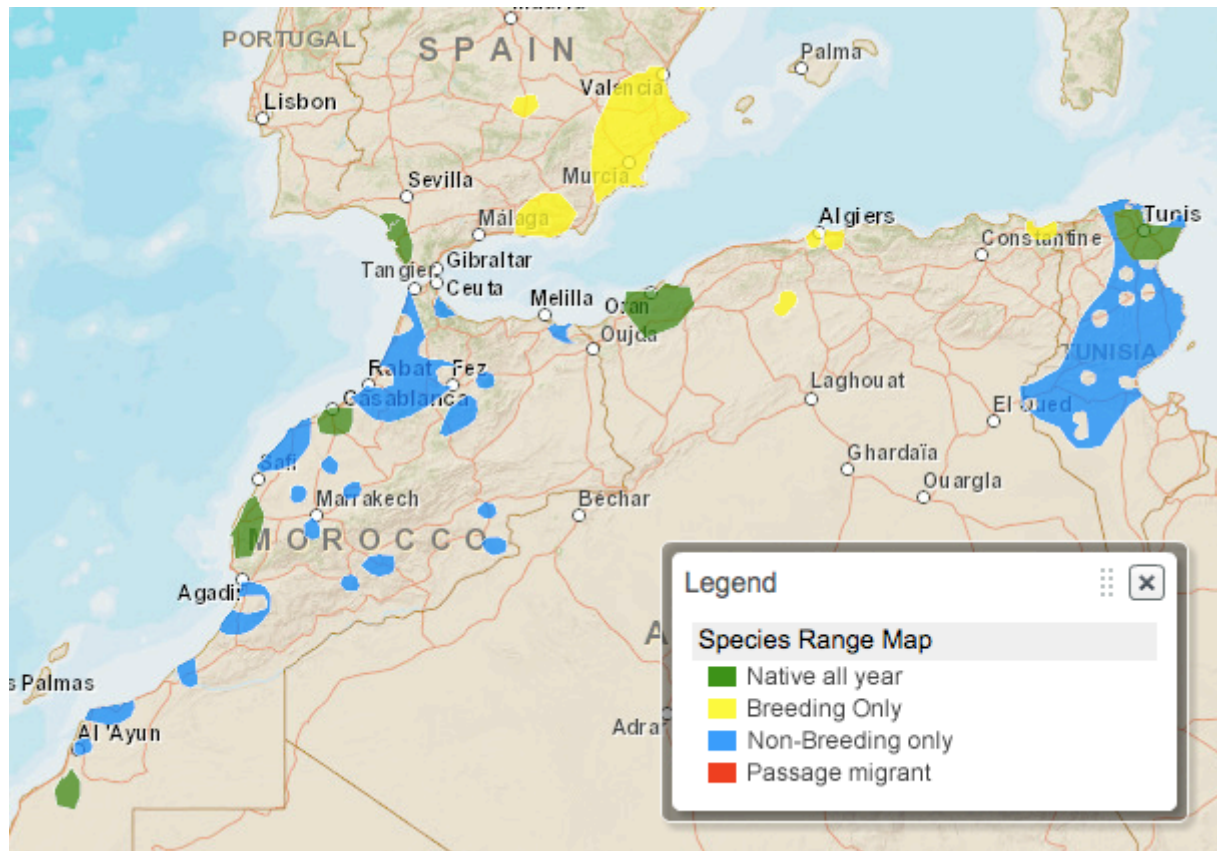

The importance of the site for the species in relation to other sites in Morocco is provided in the table below.

Site name	Season	Mean	Units
Barrage al Massira	winter	1973	Individuals
Sidi Moussa - Oualidia	winter	1420	Individuals
Parc Naturel d'Ifrane	winter	1200	Individuals
Plage Blanche - Ras Takoumba	winter	550	Individuals
Dwiyate	winter	550	Individuals
Canton Forestier de Sidi Bou Ghaba	winter	480	Individuals
Merzouga/Tamezguidat	winter	350	Individuals
Parc National de Souss-Massa and Aglou	winter	350	Individuals
Merja de l'Wad Fouwarane (Kenitra)	non-breeding	249	Unknown
Baarage Mechra Hommadi	winter	209	Unknown
Sebkha Zima	winter	200	Individuals
<b>Barrage al Mansour Ad-Dhabi</b>	<b>passage</b>	<b>187</b>	<b>Individuals</b>
Marais Larache	winter	100	Individuals
Barrage Mohamed V	breeding	91	breeding pairs
Dayet al Hafs (Jorf Lasfar)	non-breeding	78	Unknown
Embouchure Oued Moulouya	winter	38	Individuals
Merja Zerga	winter	30	Individuals

Msseyed	winter	30	Individuals
Embouchure Oued Moulouya	breeding	9	Unknown

Form the information provided above it can be concluded that the reservoir does not play a critical role in the conservation of this vulnerable species. The reservoir is nevertheless a SIBE, part of a RAMSAR site, a valuable ecosystem and provides valuable ecological services to the population. Therefore the impact of the project on the reservoir needs to be appropriately assessed and mitigated.

### Threats to the Mansour Ad-Dhabi reservoir

The reservoir area is public land, administered by AEFCS and the Service des Travaux Publics. Human activities include fishing, livestock-grazing and reed-cutting around the reservoir's shores.

According to the IBA assessment, the main threat to the ecosystem is the discharge of wastewater from the town of Ouarzazate into the eastern end of the reservoir, and consequent organic and chemical pollution.

Even though water abstraction is not mentioned as a threat, it needs to be assessed, as it poses a potential threat and may increase the impact of existing pollution from the city of Ouarzazate, if less water is available for dilution.

## 11.4 Sensitive Receptors

The table below outlines the identified receptors in relation to biodiversity as well as the determined sensitivity of those receptors.

**Table 11-1 Ecology – Receptor Sensitivity**

Receptor	Sensitivity	Justification
Flora (onsite)	Low	Although the site is a greenfield, it is located on a plateau, within a naturally arid region. The geomorphology of the site is gravel with rock and ephemeral streams that only temporarily retain water after a rain event. The ecology of the site is limited to few hardy plant species and opportunist and highly adaptable fauna.
Fauna (onsite)	Low	
Biosphere Reserve	High	The biosphere reserve is a protected area that includes a variety of ecosystem that are under pressure due to anthropogenic impacts.
Mansour Ad-Dhabi reservoir	High	Even though the reservoir is not critical in terms of protection of endangered species, it is part of a designated RAMSAR site, IBA, and SIBE and is therefore considered to have a high sensitivity.
Migratory birds	Medium	Migratory birds could be affected by the proposed project when flying over the project site due to the proximity of the Mansour Ad-Dhabi reservoir.



---

## 11.5 Construction Assessment

### 11.5.1 Initial Impacts

The baseline survey showed that the site exhibits limited biodiversity, with the main vegetation and supporting fauna restricted to the chaabas and escarpments. The requirements for the design and layout of the plant will necessitate site clearance and excavation, which will eliminate any remaining flora on the site and disturb any fauna on or near the site.

In addition to the existing site disturbances, the removal of soils for levelling and grading of the site may reduce the seed bank for future growth. It is possible that regrowth will occur to a certain extent where areas of ground are undeveloped. However, given that the site will be levelled and that a drainage system will be built, it is unlikely for regrowth similar to the chaabas vegetation to take place.

Construction activities will change the land use in the project area, which is within Zone B of the South Moroccan Oasis Biosphere Reserve. This zone is defined as a "buffer zone" with the objective of only permitting developments that are compatible with conservation principles. The plan acknowledges the need for energy generation and favours renewable energy, so the solar plant is considered to comply with the land uses allowed in zone B by the management plan. The biosphere reserve is 72,000 km<sup>2</sup>, and the project site will occupy 6.8 km<sup>2</sup>, adjacent to the existing NOORo 1 facility.

The equipment and machinery used on site will generate fairly high volumes of noise which could disturb fauna within the vicinity, though given the lack of macro-organisms identified on site, this can be assessed to be a permanent impact of moderate negative significance.

The abstraction of water from the Mansour Ad Dahbi reservoir for construction could potentially have an impact on the wetland ecosystem. As described in the water chapter, the calculated capacity of the reservoir was estimated at 439 hm<sup>3</sup> in 2010. Contributions to the Mansour Ed Dahbi dam average 420 hm<sup>3</sup> per year (varies from 68 to 1300 hm<sup>3</sup>). The rate of filling of the dam has experienced fluctuations over the years ranging from 12% to 40% and over 90% in the last few years (97% on 04/05/2010). The provision reserved for drinking water from the Mansour Ed Dahbi dam is 3.5 to 4 hm<sup>3</sup>/year against approximately 180 million m<sup>3</sup>/year for irrigation. Evaporation losses are estimated at about 56 m<sup>3</sup>/year. The water use during construction of NOORo II CSP will be 0.4 hm<sup>3</sup> over 29 months (0.12 hm<sup>3</sup>/year). This represents 0.02% of the average contribution to the Mansour Ed Dahbi Reservoir, that is 420 hm<sup>3</sup>, and 0.17% of the lowest recorded yearly contribution to the reservoir, that was 68 hm<sup>3</sup>. It is highly unlikely that these minor quantities of water abstraction might have any noticeable impact on the ecosystem.

**Table 11-2 Ecology – Magnitude of Construction Impacts**

Impact	Magnitude	Justification
Direct Loss of habitat (onsite)	Moderate	The baseline survey indicated that the site and surrounding areas exhibits little biodiversity, with limited vegetation or fauna as a result of geomorphology. The requirements for the design and layout of the plant will necessitate site clearance, which will disturb any remaining fauna and flora on the site.
Loss of seedbank	Moderate	Site clearing and earth moving will alter the diversity and density of seeds in the soils. Removal of the vegetation will also limit the redeposition of new seeds, and soil compaction will prevent regrowth of any seeds remaining on site.
Noise impact on fauna	Moderate	The equipment and machinery used on site may generate high volumes of noise that could disturb fauna within the vicinity. However, the lack of macro-organisms identified on site, use of the adjacent lands by villagers and nomads, and the construction of NOORo 1, has further limited the presence of fauna.
Land use change within the Biosphere Reserve	Negligible	Renewable energy projects are allowed for in zone B of the Biosphere Reserve by the Management Plan. The land use change will affect a very small area of the reserve, take place in an area of low biodiversity value and adjacent to the NOORo 1 CSP.
Impact of water abstraction on the wetland ecosystem	Negligible	Small quantities of water will be abstracted from the reservoir during construction. This could potentially result in a temporary minor loss or detrimental alteration of the wetland ecosystem.

**Table 11-3 Ecology – Significance of Construction Impacts**

Impact	Magnitude	Receptor	Sensitivity	Impact Significance
Direct Loss of habitat	Moderate	Flora (onsite)	Low	Minor
		Fauna (onsite)	Low	Minor
Loss of seedbank	Moderate	Flora (onsite)	Low	Minor
Noise impact on fauna	Moderate	Fauna (onsite)	Low	Minor
Land use change within the Biosphere Reserve	Negligible	Biosphere Reserve	High	Minor
Impact of water abstraction on the wetland ecosystem	Negligible	Mansour Ad-Dhabi reservoir	High	Minor

### 11.5.2 Mitigation Measures

In common with WB/IFC Performance Standard 6: Biodiversity Conservation and Sustainable Management of Living Natural Resources and recommendations set out within the

Requirements Construction Environmental and Social Management Plan, the loss of native vegetation should be offset through re-vegetation of the site.

- None of the plant life in the area of activity and its perimeter is considered to be a rare or threatened species of flora or fauna. However, systematic routes will be covered prior to the entry of machinery onto the site to detect any areas of interest to fauna, such as burrows, nests, sleeping places, resting places, etc. that could be affected by noise emissions. Ditches and site areas where animals could become trapped will also be regularly inspected.
- Unnecessary cutting of vegetation, especially in areas around the Chaabas will be avoided.
- Re-vegetation in places where colonisation is difficult or in the interest of accelerating the process will be carried out.
- All auxiliary roads will be removed, and any installed platforms will be scarified. Base layers will be removed and waste taken to the appropriate waste landfill facility.
- Any foundation holes, effluent channels, wells will be backfilled and covered with soil in order to homogenise the appearance of the area.
- Particular effort will be considered in the selection of the vegetation and location of planting in order to successfully achieve 'in-kind' remediation of the Chaabas, as these were noted as the key biodiversity habitats.
- At the construction stage, the topsoil will be removed and stored safely and spread over the site once construction has been completed.
- Any excess cut that will not be used in the cut/fill balance of the site will be disposed at an appropriate location, where no damage to Chaabas, or habitats may occur. Therefore disposal of the excess soil, will not be within the Chaabas at the periphery of the site. Alternatively, the excess fill may be sold to neighbouring developments, which may have a shortage of soils.
- The laydown areas of the site will be minimised in size wherever possible, and preferably located in areas with little or no vegetation, wherever possible. The contractor will ensure that no encroachment to the nearby, adjacent land should occur and that all construction vehicles adhere to clearly defined transportation routes.
- Hazardous materials used during the construction stage will be adequately stored and handled, in order to minimise the potential risk of spillage and therefore potential contamination to the soils and negative impact on the ecosystem.
- Transportation within and to/from the site will be minimised through efficient transport management in order to minimise noise and vehicle pollution. Transport routes will be

identified and strict adherence to designated routes will be enforced, in order to protect the existing vegetation and reduce encroachment on adjacent land.

- Machinery will be maintained and stored in designated areas within the construction compound. No plant maintenance will be carried out on open ground, off the main routes or on adjacent undisturbed desert areas. Washing down of vehicles and particularly cement truck washing activities will be carried out over sealed grounds, in designated purpose built areas to capture the run off in settlement tanks.

### 11.5.3 Residual Impacts

Following the implementation of the mitigation measures described above, and considering the relatively limited ecological value of the site, it is considered that the residual impacts upon the terrestrial ecology of the site will be of minor negative significance. This is due to the fact that despite recommended mitigation measures to encourage re-establishment of chaaba vegetation along the perimeter of the Project site, the development will result in the loss of habitat, particularly in relation to reptiles and resident birds that inhabit this region.

**Table 11-4 Ecology – Significance of Construction Impacts**

Impact	Magnitude	Receptor	Sensitivity	Impact Significance	Mitigation	Residual Impact Significance
Direct Loss of habitat	Moderate	Flora	Low	Minor	Yes	Minor
		Fauna	Low	Minor	Yes	Minor
Loss of seedbank	Moderate	Flora	Low	Minor	Yes	Minor
Noise impact on fauna	Moderate	Fauna	Medium	Moderate	Yes	Minor
Land use change within the Biosphere Reserve	Negligible	Biosphere Reserve	High	Minor	Yes	Negligible to Minor
Impact of water abstraction on the wetland ecosystem	Negligible	Mansour Ad-Dhabi reservoir	High	Minor	Yes	Negligible to Minor

## 11.6 Operation Assessment

### 11.6.1 Initial Impacts

The potential impacts of avifauna of parabolic CSP technology have received attention recently after the publication of monitoring data from parabolic CSP plants in the US showing avian mortality rates higher than expected. The National Fish and Wildlife Forensics

Laboratory has prepared a preliminary analysis on Avian Mortality at Solar Energy Facilities in Southern California (Kagan et al. 2014) comparing different technologies.

Avian Mortality study at Solar Energy Facilities in Southern California undertaken by the National Fish and Wildlife Forensics Laboratory studied a PV facility (Desert Sunlight) a CSP Parabolic (Genesis) and a CSP tower (Ivanpah).

**Table 11-5 Mortality rates by power plants and type of bird**

Site	Num Remains	Identifiable Remains	Foraging Zone		Residency Status		
			Resident	Migrant	Air	Terr	Water
Ivanpah CSP Tower	141	127	63	64	28	85	14
Genesis CSP Parabolic	31	30	20	10	12	12	6
Desert Sun PV	61	56	18	38	7	22	27
<b>TOTAL</b>	<b>233</b>	<b>213</b>	<b>101</b>	<b>112</b>	<b>47</b>	<b>119</b>	<b>47</b>

**Table 11-6 Cause of death by power plant**

Cause of Death	Ivanpah CSP Tower	Genesis CSP Parabolic	Desert sunlight PV	Total
Solar Flux	47	0	0	47
Impact Trauma	24	6	19	49
Predation Trauma	5	2	15	22
Undetermined Trauma	14	0	0	14
Electrocution	1	0	0	1
Emaciation	1	0	0	1
Undetermined	46	17	22	85
No evident cause	3	6	5	14
<b>TOTAL</b>	<b>141</b>	<b>31</b>	<b>61</b>	<b>233</b>

The number of bird fatalities reported in this study has to be interpreted with caution. The methodology included collection of carcasses by either US fish and wildlife service employees or energy company staff. This was done on an opportunistic manner, not according to a pre-determined sampling schedule or protocol.

The three solar facilities studied are located in a desert environment. The tower CSP facility had the highest bird mortality rate, as a result of the solar flux area and a higher number of impacts. It has been suggested that large areas of reflected blue panels can be confused with a water surface by water birds, causing collisions. In the Desert Sunlight PV facility the water bird mortality (44%) is much higher than in the Genesis Parabolic CSP (19%) and Ivanpah Tower CSP (10%). The article suggests that this is because the size and continuity of the PV panels have more of a water surface appearance, while parabolic mirrors combine transects of reflective and non reflective surfaces.

In order to establish the significance of avian mortality caused by solar plants it is necessary to consider, inter alia, the bird mortality caused by other anthropogenic sources. The results

of two studies prepared by public authorities in the US and in Canada providing information about bird mortality caused by anthropogenic activities are summarised below.

Summary of predicted annual avian mortality in the US

Mortality source	Annual mortality estimate	Percent composition
Buildings	550 million	58.2 percent
Power lines	130 million	13.7 percent
Cats	100 million	10.6 percent
Automobiles	80 million	8.5 percent
Pesticides	67 million	7.1 percent
Communications towers	4.5 million	0.5 percent
Wind turbines	28.5 thousand	<0.01 percent
Airplanes	25 thousand	<0.01 percent
Other sources (oil spills, oil seeps, fishing by-catch, etc.)	Not calculated	Not calculated

Source: Wallace P. Erickson, Gregory D. Johnson, and David P. Young Jr.2 (2005) A Summary and Comparison of Bird Mortality from Anthropogenic Causes with an Emphasis on Collisions USDA Forest Service Gen. Tech. Rep. PSW-GTR-191. 2005

Mortality estimates of human-related avian mortality in Canada derived directly from published papers and unpublished reports

Human related activity	Estimation			Life Stage
	Lower	Central	Upper	
Cats – Feral	49,000,000	116,000,000	232,000,000	Individuals
Cats - Domestic	27,000,000	80,000,000	186,000,000	Individuals
Power - Transmission line collisions	10,100,000	25,600,000	41,200,000	Individuals
Buildings - Houses	15,800,000	22,400,000	30,500,000	Individuals
Transportation - Road vehicle collisions	8,914,341	13,810,906	18,707,470	Individuals
Agriculture - Pesticides	960,011	2,695,415	4,430,819	Individuals
Harvest - Migratory birds		2,279,655		Individuals
Buildings – Low – and -midrise	300,000	2,400,000	11,400,000	Individuals
Harvest – Non migratory birds	1,076,810	2,389,124	3,701,438	Individuals
Forestry-Commercial	615,959	1,351,340	2,086,720	Nests
Transportation-Chronic ship – source oil	217,800	321,900	458,600	Individuals
Power - Electrocutions	160,836	481,399	801,962	Individuals
Agriculture - Haying		2,209,400		Eggs or nestlings
Power - Line maintenance	258,849	388,274	592,418	Nests
Communication - Tower collisions		220,649		Individuals
Power – Hydro reservoirs		152,162		Nests
Buildings - Tall	13,000	64,000	149,000	Individuals
Fisheries - Marine gill nets	2185	20,612	41,528	Individuals
Power - Wind energy	13,330	16,700	21,600	Individuals
Oil and Gas - Well sites	7688	13,182	20,249	Nests
Mining - Pits and quarries		125,529		Eggs or nestlings
Oil and Gas - pipelines	503	6314	30,234	Nests
Mining – Metals and minerals	18,653	69,211	119,768	Eggs or nestlings
Oil and Gas – Oil sands	1281	2939	5236	Nests



Oil and Gas - Seismic exploration	374	2280	16,438	Nests
Fisheries – Marine long lines and trawls	494	1,999	4058	Individuals
Transportation – Road maintenance	13,086	25,149	50,294	Eggs or nestlings
Oil and Gas - Marine	188	2244	4494	Individuals

Source: Calvert, A. M., C. A. Bishop, R. D. Elliot, E. A. Krebs, T. M. Kydd, C. S. Machtans, and G. J. Robertson (2013) A synthesis of human-related avian mortality in Canada. Avian Conservation and Ecology. Environment Canada

In conclusion, the avian mortality caused by parabolic CSP plants is low compared to other solar technologies and compared to the mortality caused by other human activities. However, mitigation is required to minimise avian fatalities and monitoring is required to obtain more detailed information to allow for a better understanding of the impacts of solar technology on avifauna. The CESMP and OESMP should specify mitigation measures to reduce the impacts.

Potential impacts could occur on the Mansour Ed Dhabi Ecosystem due to the abstraction of water for the project.

The graphic below shows the water consumption for different options of Parabolic CSP plants in California. The water consumption of NOORo II will be 0.21m<sup>3</sup>/MWh, that compares positively to all the options described in the NREL report, including the dry cooling options. This shows that the proposed design for the NOORo II facility is very effective in terms of water use.

**Figure 11-3 Water use of Parabolic CSP plants by different cooling options**

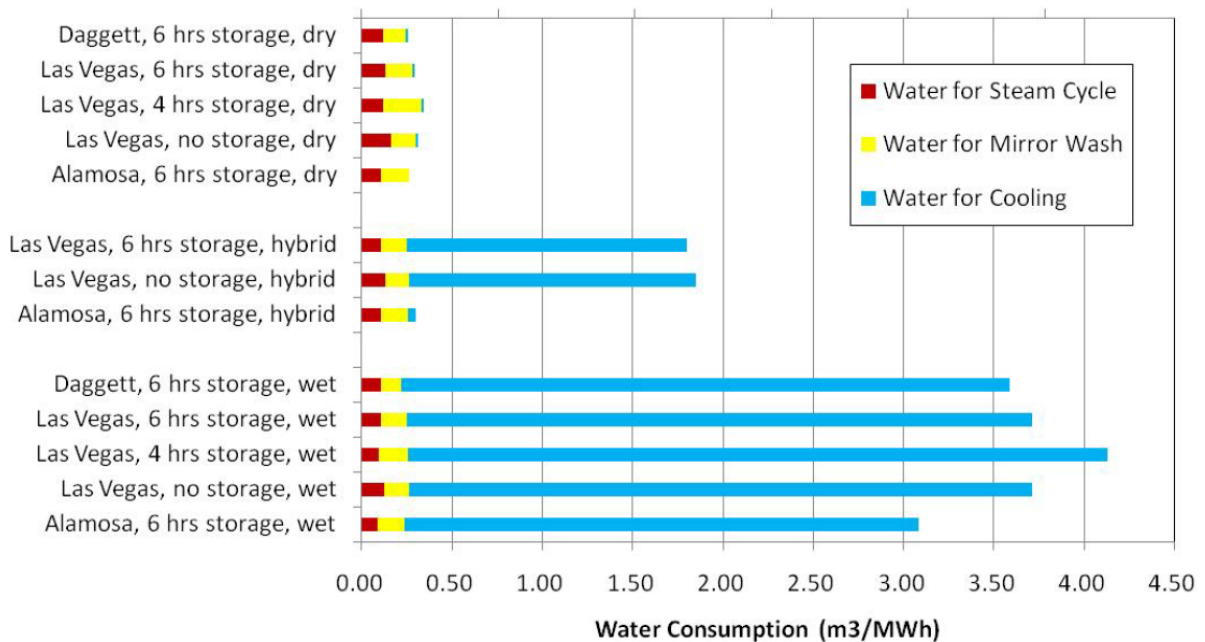

Source: C.S. Turchi, M.J. Wagner, and C.F. Kutscher Water Use in Parabolic Trough Power Plants: Summary Results from WorleyParsons' Analyses. NREL, U.S. Department of Energy, Office of Energy Efficiency & Renewable Energy

As described in the water chapter, the calculated capacity of the reservoir was estimated at 439 hm<sup>3</sup> in 2010. Contributions to the Mansour Ed Dahbi dam average 420 hm<sup>3</sup> per year (varies from 68 to 1300 hm<sup>3</sup>). The rate of filling of the dam has experienced fluctuations over the years ranging from 12% to 40% and over 90% in the last few years (97% on 04/05/2010). The provision reserved for drinking water from the Mansour Ed Dahbi dam is 3.5 to 4 hm<sup>3</sup>/year against approximately 180 million m<sup>3</sup>/year for irrigation. Evaporation losses are estimated at about 56 m<sup>3</sup>/year.

The peak water requirements for the operational phase of the plant are estimated to be 41.55m<sup>3</sup>/h. Annual contributions to the Mansour Ed Dahbi reservoir average 420 hm<sup>3</sup>. The water use during the operation of NOORo II CSP will be 0.36 hm<sup>3</sup>. This represents 0.08% of the average yearly contribution to the Mansour Ed Dahbi Reservoir, and 0.52% of the lowest recorded yearly contribution to the reservoir.

The impact of water abstraction from the reservoir on the wetland ecosystem has a negligible to minor significance.

Inadequate storage and handling of hazardous materials, and inappropriate design and storage of wastes could result with contamination of soils and groundwater and attract pest species and spread disease.

Inappropriate or insufficient wastewater management and stormwater management could result with contaminated water discharging to the Mansour Ed Dahbi Lake, which is located downstream of the proposed construction area, and this could damage the valuable wetland ecosystem.

Air emissions from the plant will include SO<sub>x</sub>, NO<sub>x</sub>, CO, CO<sub>2</sub>, O<sub>3</sub>, and PM<sub>10</sub>. However the emissions will be minimal and intermittent, therefore the impacts on the flora and fauna are not likely and are considered negligible.

**Table 11-7 Ecology – Magnitude of Operation Impacts**

Impact	Magnitude	Justification
Pests from domestic waste	Minor	Pests may pose a very minor temporary reversible loss of biodiversity through the spread of disease and nuisance to native habitats in the site and immediate surroundings.
Wastewater Discharge	Minor to Moderate	Poor Wastewater management may potentially impact on both the soils and reservoir Water quality through run-off.
Herbicides and pesticides	Minor	Inadequate management and selection of persistent non-biodegradable landscape chemicals may be toxic to birds and also impact on the local vegetation, thereby increasing the secondary poisoning of non-targeted species.
Ecosystem changes as a result of water abstraction	Minor	The plant is very efficient in the use of water and the water abstraction required is minor in relation to the water inflow rate and when compared to other anthropogenic uses.

Bird mortality and morbidity	Minor	The existing evidence suggests that parabolic CSP plants have an impact on avian mortality, and that this impact could be particularly significant for water birds.
------------------------------	-------	---

**Table 11-8 Ecology – Significance of Operation Impacts**

Impact	Magnitude	Receptor	Sensitivity	Impact Significance
Pests from domestic waste	Minor	Fauna (onsite)	Low	Negligible to Minor
Hazardous Material Storage	Minor	Fauna (onsite)	Low	Negligible to Minor
Wastewater Discharge	Moderate	Fauna (onsite)	Low	Minor
Herbicides and pesticides	Minor	Flora	Low	Negligible to Minor
Ecosystem changes as a result of water abstraction	Minor	Mansour Ad-Dhabi reservoir	High	Moderate
Bird mortality and morbidity	Minor	Migratory birds	Medium	Minor to Moderate

#### 11.6.2 Mitigation Measures

Although the terrestrial ecology on the site is not of high value, it remains important to consider ways to minimise the impact and potentially improve on the terrestrial environment of the Project Site and surrounding area during the Solar Plant's operations.

Although, the majority of the site will be built up, there may be some opportunities to promote vegetation within the complex's boundaries. Consequently, the following considerations should be made:

- Landscaping: Using large shrubs or trees onsite is not recommended, as the existing evidence suggests that it attracts both birds and insects to the site, and this will increase bird mortality as a result of the neighbouring solar tower technology of NOORo III.
- The evaporation ponds will be covered (e.g. by a net) to avoid aquatic birds accessing them;
- An integrated pest management scheme will be developed for the plant, in preference to the use of large scale pesticides and detailed within the Operational Environmental Management Plan;
- Transport routes on site and training will emphasise that vehicles and employees should keep to the designated routes in order to prevent unnecessary land encroachment, thus protecting the natural resources and reducing dust emissions;
- Appropriate storage of hazardous materials, will be designed in accordance with the IFC and World Bank guidelines, preventing any major spillages on the site.

- The mechanisms for water treatment and re-use that have been included in the plant design to minimise water consumption are described in the water chapter.
- A monitoring plan will be undertaken, either for each plant separately or for the entire SPC, to monitor avian fatalities. Monitoring will be undertaken daily for at least the first two years of operation of the plant.
- A mitigation plan to avoid impacts on avifauna cannot be efficiently implemented for a single project when three large plants are developed adjacent to each other. The FESIA overlooked this potentially significant impact, so no mitigation was put in place for the entire SPC. The plant that is likely to have the higher impact on avian fatalities will be NOORo III, due to the use of the parabolic technology. An avifauna monitoring programme run by an ornithologist based on the SPC should be put in place to quantify the magnitude of the impacts.
- Since there is a lack of scientific certainty on the impacts of solar facilities on avifauna, an adaptive approach is recommended for the management of this potential impact. The results of the monitoring plan outlined above will be used to determine if mitigation is required. If the monitoring programme identifies high avian mortality rates, a mitigation programme will be designed including measures such as those outlined below. It should be noted that the choice of mitigation will depend on the results of the monitoring (e.g. bird species, resident or migratory, time of the year). The SPC shall submit the monitoring data of the three first months after the start of operations to MASEN, the IFIs and MEMEE, and if necessary an Avian Impacts Mitigation Plan will be put forward to address the identified impact. The Plan will be implemented before the fifth month of operation and will be integrated in the OESMP. The monitoring results for the first year of operation will also be submitted to MASEN, the IFIs and MEMEE, and the Avian Impacts Mitigation Plan will be updated to include the seasonal variation patterns identified in the annual data. ACWA Power will select some of the mitigation techniques outlined below, implement them and assess their effectiveness, either one by one or in combination, until a method or combination of methods is found to significantly reduce avian fatalities. The potential avian mortality avoidance methods outlined below are based on the review of international research literature regarding the effectiveness of bird scaring techniques undertaken by Bishop et al (2003). Other methods are expected to be developed in the near future, as the impact of solar facilities on avifauna has only recently received attention. Mitigation techniques not included in the list below can also be proposed by the consortium.
  - Model predators rely on mimicry of real predators and evocation of fear and avoidance in the target species. Most potential prey species react to

predator models. The strength of the response, however, varies between species. In the USA, museum-mounted models of a sharp-shinned hawk *Accipiter striatus* and goshawk *Accipiter gentilis* both reduced the numbers of birds visiting the feeding stations under study. Habituation to the models, however, was relatively quick with birds reentering the feeding area after only 5-8 hours exposure. Studies in farming areas showed that mobile models (e.g. wings that moved in the breeze or battery-powered wings that could move in the absence of wind) reduced crop damage by 81%.

- Gas cannons are mechanical devices that produce loud banging noises by igniting either acetylene or propane gas. Their scaring effect is probably related to the similarity of the noise to that of a shotgun. The unexpected bang produced causes a 'startle' reflex and promotes escape flight on birds. Habituation seems to be the main reason for their loss of effectiveness; a cannon firing repeatedly without any variation in timing or direction quickly loses its potential to scare birds. Although gas cannons can be effective bird scarers if the firing frequency and direction is varied, there is public concern with noise nuisance. Noise levels in Tasselmant should be assessed before this method is adopted.
- Pyrotechnics include a wide variety of noise-producing cartridges usually fired from rockets or rope bangers. At airports in the UK, shell crackers fired from a modified pistol are the commonest means of dispersing birds, as they allow the bird controller to have some directional control over birds in flight, so they can be steered away from runways. Noise levels in Tasselmant should be assessed before this method is adopted, pyrotechnics should not be used in situations where there could be a fire hazard, and the type of pyrotechnic material should not result in debris that could fall on the mirrors of the tower CSP.
- Bio-acoustic deterrents are sonic devices that transmit sounds of biological relevance, such as recorded bird alarm and distress calls. In general, alarm calls are given when birds perceive danger, whilst distress calls are vocalised when birds are captured, restrained or injured. A number of sonic devices and pre-recorded alarm and distress calls are now readily available commercially and such devices are widely used for bird control. However, exposure to a sound that originates from the same location can quickly encourage habituation.
- Falconry is an expensive method of bird control as the birds require special care and training and a specialist handler, and often a number of falcons

must be provided to operate at different times of the day. However, falconry is popular with the public as it is environmentally friendly and considered humane as the target birds are not killed but merely chased from the area, though the most effective falconry does involve the occasional killing of the prey species.

- Radio-controlled model aircraft have been used to scare or 'haze' birds since the early 1980s, mainly over airfields, but have also been used over agricultural areas, fisheries and landfill sites. This method has been shown to be very effective and birds habituate more slowly to a treatment in which they are being actively hazed.

### 11.6.3 Residual Impacts

Following the mitigation and management techniques outlined above, which are further described within the Operational Environmental Management Plan, the residual impacts are generally expected to be of negligible to minor negative significance.

However, the implementation of the landscaping mitigation may result in a permanent minor positive impact upon the biodiversity of the area by providing suitable habitats for small mammals and reptiles.

**Table 11-9 Ecology – Residual Impacts – Operation Phase**

Impact	Magnitude	Receptor	Sensitivity	Impact Significance	Mitigation	Residual Impact Significance
Pests from domestic waste	Minor	Fauna	Medium	Minor	Yes	Negligible
Hazardous Material Storage	Minor	Fauna	Medium	Minor	Yes	Negligible
Wastewater Discharge	Minor to Moderate	Fauna	Medium	Minor	Yes	Negligible
Herbicides and pesticides	Minor	Flora	Low	Negligible to Minor	Yes	Negligible
Ecosystem changes as a result of water abstraction	Minor	Mansour Ad-Dhabi reservoir	High	Moderate	Yes	Minor
Bird mortality and morbidity	Minor	Migratory birds	Medium	Minor to Moderate	Yes	Minor



---

## 12 SOCIAL AND ECONOMIC ISSUES

### 12.1 Introduction

This chapter of the SESIA Report focuses on the social and economic issues, both direct and secondary, associated with the development and subsequent operation of the NOORo II CSP. Initially this chapter considers the baseline socio-economic environment within which the development will proceed, before examining the potential impact of the development during the various stages of the project lifecycle. For this chapter particular attention was paid to the results of the public consultation. Where necessary and possible, opportunities to pursue measures to minimise and / or mitigate any impacts have been developed and put forward.

Regarding the current land use of the project site, there are no settlements on the site, which is fully owned by MASEN. The assessment of the social and economic impacts of land acquisition for the Solar Power Complex was addressed in the FESIA. Additionally, land acquisition procedures for the site are documented in the Land Acquisition Plan (LAP) finalized in July 2011. Since the start of construction of the NOORo I CSP, the land for NOORo II and NOORo III is no longer being used as a passage to grazing land in the lower Oueds.

### 12.2 Methodology

This chapter looks at key indicators relating to factors such as population, the economy, the labour market and social development at a regional level. Where relevant, professional judgement was drawn upon, including knowledge from site visits and information collected during consultations with interested parties to augment the secondary baseline data.

Once this baseline was established the report considered a more detailed assessment of the impacts of the development. As the development will have different socio-economic impacts throughout the lifecycle of the project, impacts during construction and operation are discussed separately.

In reflection to the requirements of the IFC Performance Standards, core components of this analysis include:

- A review of any local communities within the proposed development site and its immediate environs, incorporating views on settlement, grazing rights and other activities;
- A review of any settlements arising from construction of the facility;
- An assessment of local labour market impacts;
- An outline assessment of any health and safety implications of the facility;

- An assessment of impact upon local services; and
- The suitability of the site in light of the social / development profile of the site environs.

The viewpoints of relevant stakeholders into such a nationally important development and mitigation for the social or economic concerns of these stakeholders had already been incorporated at the strategic level during the FESIA, and the specific input from the local consultation process regarding the second phase is particularly relevant for this social and economic assessment.

### 12.3 Baseline

The NOORo II Solar Complex is located in the Ghassate commune, in the province of Ouarzazate. Ghassate is a rural, sparsely populated commune. In 2004 the population was 8,815 inhabitants. The commune has shown a population decrease of -2.4% between 1994 and 2004 due to migration to Ouarzazate, Agadir, Casablanca or international cities. In 2004 the city of Ouarzazate had a population of 56,616. The official unemployment rate (i.e. population receiving unemployment benefits) is 6.5% in the province of Sous Massa Draa.

The villages that are closer to the project site (i.e. Tasselmant, Tiflite, Igherm Amellal, Tidgheste, Taferghouste) grow crops in the bottom of ephemeral river valleys. The main types of crops include date palm, fruit trees (e.g. olive trees) and annual and forage crops. The crop planting areas have been included as sensitive receptors, as they are essential for the economic well being of these villages and impacts on these areas have to be avoided.

The province has a significant tourist industry, for which the cultural heritage and the landscape are important factors that need to be considered and maintained. The cultural heritage and the landscape are also essential for the film studios located near the city of Ouarzazate. Impact on archaeology and heritage, as well as landscape are specifically discussed in chapters 14 and 15 respectively, but the impact on the tourist industry is assessed in this chapter.

The sites for NOORo 1, 2, and 3 is fully owned by MASEN. The acquisition of the Field for the SPC was completed on the 18th of October 2010 Land purchase Agreement between the Ait Oukroun Toundout as Seller and l'Office National de l'Électricité as a buyer. Property of the land was then transferred from l'Office National de l'Électricité to MASEN. The land acquisition process fulfilled all the legal requirements (e.g. the certificate of non-farming the land). Regarding the current land use of the project site, there are no settlements on the site. The assessment of the social and economic impacts of land acquisition for the Solar Power Complex was addressed on the FESIA.

## 12.4 Sensitive Receptors

**Table 12-1 Socio-economic – Receptor Sensitivity**

Receptor	Sensitivity	Justification
Employment	Medium	The project will provide year round and longterm employment opportunities for the villagers and residents of Ouarzazate
Local / Regional Economy	Medium	The guaranteed supply of power, and new jobs will help to increase economic development in the neighbouring villages and Ouarzazate.

## 12.5 Construction Assessment

### 12.5.1 Initial Impacts

The site was previously used by pastoralists for passage, however under a voluntary agreement and in accordance with the national land acquisition process, MASEN purchased and took ownership of the land in mid 2011. As part of the purchase agreement and in order to ensure that the pastoralists and villagers would not be negatively impacted by the purchase of the land, MASEN agreed to shoulder the cost for construction of the new road recently completed for access to the village of Tasselmant.

The primary economic positive impact during construction is likely to result from any local employment creation and the use of local businesses/services. The workforce that will be employed during the construction phase will range from 200 to 1,200 workers at the peak of construction. Given the unemployment levels within Morocco and the emigration rates in the rural commune of Ghassate, any creation of jobs is likely to prove welcome. As well as the direct monetary uplift to the families of those employed, money paid to local workers will also stimulate the local economy via the multiplier effect, whereby money earned on the project expended locally will re-circulate within the local economy. Whilst we have no evidence quantifying the multiplier effect within the Kingdom of Morocco, studies undertaken in Europe and the US suggests the impact of expenditure on a local economy prior to leakage to be in the order of 4:1.

Notwithstanding the above, it is likely that the lack of some necessary skills within the immediate local population will require a proportion of work on the site to be undertaken by immigrant population. This could result in the repatriation of wages, with benefits to the local economy potentially being reduced. Within the province of Ouarzazate, particularly in the Ghassate commune and the city of Ouarzazate, this impact is considered to be of moderate positive significance.

In addition to the direct monetary impact of employment created during construction, there also exists the potential for the project to promote the dissemination of best practice

construction skills into the local labour force. To the extent that the development proves an enabler for further regional development, any skills acquired are likely to prove readily marketable in the aftermath of the project construction. A further secondary impact is likely to arise from spending on local goods during the construction process. These secondary impacts are likely to result in a minor positive impact upon the local economy.

The cultural heritage and the natural landscape are important for the tourist industry at Ouarzazate. As it is explained on Chapter 14 and 15, the impacts on the cultural and natural landscape are not expected to be significant, so from an economic perspective the potential negative impact on tourism is assessed as negligible.

However, it should be noted that minor negative impacts to the workers welfare may result during the construction phase, due to health and safety issues related to traffic, noise and air quality. Impacts related to transport and roads are discussed in Chapter 13.

With regards to the seasonal pastoralists, the site area is insignificant in relation to the large amount of open land that supports better vegetation for the pastoralist's herds. In densely populated areas where there is intensive competing land uses the fencing and development of a site can have a significant impacts on the activities of nomadic pastoralists, due to the cumulative nature of the impact. However, the area of the Ouarzazate Solar Complex is sparsely populated, and the plateau only offers low quality vegetation for grazing. Therefore, it is considered that the impact on the pastoralists will be of minor negative significance.

**Table 12-2 Socio-economic – Magnitude of Construction Impacts**

Impact	Magnitude	Justification
Employment creation	Moderate Positive	Temporary creation of employment relating to construction will be likely and should benefit the local/regional area.
Dissemination of skills	Minor Positive	Dissemination of know-how among the construction force.
Purchase goods and materials from the local / regional economy	Minor Positive	Minor increase in the purchase of goods and services by the workforce and of construction materials within the local/regional area.
Tourisms	Negligible	The Ouarzazate area draws tourists for the architecture and movie industry. The project site is far from these cultural attractions and will not impact their landscape.
Access to Pastoralists	Minor Negative	Access to the site for grazing will be restricted, however the quality of grazing off site is far superior.

**Table 12-3 Socio-economic – Significance of Construction Impacts**

Impact	Magnitude	Receptor	Sensitivity	Impact Significance
Employment creation	Moderate Positive	Employment	Medium	Moderate Positive
Dissemination of skills	Minor Positive	Employment	Medium	Minor Positive
Purchase goods and materials from the local / regional economy	Minor Positive	Employment	Medium	Minor Positive
		Local /regional economy	Medium	Minor Positive
Tourisms	Negligible	Local /regional economy	Medium	Negligible
Access to Pastoralists	Minor Negative	Local /regional economy	Medium	Minor Negative

### 12.5.2 Mitigation Measures

MASEN agreed to the upgrading and construction of a new road, to ensure that access by pastoralists and villagers across the plateau is maintained. The new road will allow the connection, in all weather, between the village of Tasselmant and the town of Ouazazate. The road connects to the main road that runs outside the south border of the site and then turns northward toward the village, parallel to the east border of the site. The construction works were completed during the construction of NOORo 1 SCP.

The project will seek to employ local workers, as was brought up during the public consultation process, where these are willing and available, and where appropriate will offer training to enhance the development of skills within the local workforce. A Recruitment Policy will be incorporated into the EPC's Construction Environmental and Social Management Plan (CESMP), which will set out the proposed measures to maximise the benefits to the local population and economy. The number of local population employed by the project and the training provided to the workforce will be monitored. The employment of women and vulnerable groups will be specifically targeted and monitored.

If migrant labour is required, adequate housing will be provided. Available accommodation locally (i.e. at the city of Ouarzazate) will be favoured. The traffic impacts are assessed in the next chapter. If temporary housing was to be provided, it shall be of high quality with appropriate amenities. The environmental and social impact of any temporary accommodation will be adequately assessed. Strict controls over the provision of housing shall prevent any unplanned settlements from developing. Unplanned settlements in the site are unlikely, as it will be monitored by security personnel.

Security personnel will adhere to international human right code of conduct.

The ESMP will include training and a plan to avoid the spread of Sexually Transmitted Diseases or other infectious diseases.

A Retrenchment Plan will be prepared by the Contractor for moving from construction to operation and decommissioning.

The Emergency Response Plan to be developed in the ESMP will take into consideration and specifically address potential risks to the communities.

Further mitigation measures are detailed in the framework CESMP, provided in Volume 3.

### 12.5.3 Residual Impacts

Following the implementation of mitigation measure and promoting socio-economic activities, the positive significance of effects is expected to increase.

**Table 12-4 Socio-economic – Residual Impacts – Construction Phase**

Impact	Magnitude	Receptor	Sensitivity	Impact Significance	Mitigation	Residual Impact Significance
Employment creation	Moderate Positive	Employment	Medium	Moderate Positive	Yes	Moderate Positive
Dissemination of skills	Minor Positive	Employment	Medium	Minor Positive	Yes	Moderate Positive
Purchase goods and materials from the local / regional economy	Minor Positive	Employment	Medium	Minor Positive	Yes	Moderate Positive
		Local /regional economy	Medium	Minor Positive	Yes	Moderate Positive
Tourisms	Negligible	Local /regional economy	Medium	Negligible	No	Neutral
Access to Pastoralists	Minor Negative	Local /regional economy	Medium	Minor Negative	Yes	Negligible

## 12.6 Operation Assessment

### 12.6.1 Initial Impacts

At a strategic level the operation of the plant offers potential to support the sustainable growth of the local and national economies, through the ability to provide a renewable source of energy for the Ouarzazate province and the Kingdom of Morocco.



The most significant economic impact upon nearby communities during operation will result from the employment opportunities created by the Project. Sixty workers will be employed in the project during the operational phase.

Even though the direct impact on local employment is not as significant as during the construction phase, the increased time-scales involved offer an opportunity for greater dissemination of skills into the local workforce and via this for the role of local workers to increase over time.

The employment benefits, the dissemination of skills and the economic development that is likely to result from the availability of sustainably produced energy is considered to be an impact of moderate positive significance.

Access to the site will remain restricted during the plant operation, so the seasonal pastoralists will not be able to cross through the site. The site area is, however, insignificant in relation to the large amount of open land that supports better vegetation for the pastoralist's herds. Furthermore, the area of the NOORo Solar Complex is sparsely populated, with the vast majority of the land being open for passage and grazing, and there are very few barriers to passage. Finally, the plateau only offers low quality vegetation for grazing. Therefore, it is considered that the impact on the pastoralists will be of minor negative significance.

The cultural heritage and the natural landscape are important for the tourist industry at Ouarzazate. There are conflicting opinions on the impact that the plant will have on tourism. On the one hand, it can be argued that tourists go to Ouarzazate due to its natural landscape and the way in which the city and surrounding villages integrate in it. From this perspective any industrial development would have a negative impact on tourism. On the other hand, a study financed by the French Development Agency stated that there is a potential for the SPC to be a tourist asset, as it is a large development that can be impressive and unique, once all the phases are developed, and it is a renewable energy project. In any case, as explained in Chapters 14 and 15, the impacts on the cultural and natural landscape are not expected to be significant (i.e. it will not be visible from the sensitive receptors), so the impact on tourism is assessed as minor.

**Table 12-5 Socio-economic – Magnitude of Operation Impacts**

Impact	Magnitude	Justification
Employment creation	Moderate Positive	An increase in permanent long term employment in the local area will result from the Operation of the retail/commercial sectors.
Dissemination of skills	Moderate Positive	Increased work experience and opportunities to improve job skills.
Tourism	Minor Positive	Diversify tourism potential for the region. Education trips for schools.
Access to Pastoralists	Minor negative	Although the site will no longer be accessible for grazing. Superior grazing fields are located in the canyons.

**Table 12-6 Socio-economic – Significance of Operation Impacts**

Impact	Magnitude	Receptor	Sensitivity	Impact Significance
Employment creation	Moderate Positive	Employment	Medium	Moderate Positive
		Local /regional economy	Medium	Moderate Positive
Dissemination of skills	Moderate Positive	Employment	Medium	Moderate Positive
		Local /regional economy	Medium	Moderate Positive
Tourism	Minor Positive	Local /regional economy	Medium	Minor Positive
Access to Pastoralists	Minor negative	Local /regional economy	Medium	Minor negative

### 12.6.2 Mitigation Measures

The potential impacts beyond the immediate term, in relation to the local community and existing services and facilities has been identified as positive. Mitigation measures to ensure that the concerns of the neighbouring villagers and welfare of the employees and residents is ensured, have been provided in Volume 3.

Furthermore, in order to maximise the benefits, the project will seek to employ local workers where possible and where appropriate will offer training to enhance the development of skills within the local workforce. Additionally, the number of local population employed by the project and the training provided to the workforce will be monitored.

MASEN may choose to open the solar field for educational visits and promotion of green/renewable technologies. Equally, given that the solar fields will be the largest in the region and a unique feature in the country, the potential to generate tourism exists.

### 12.6.3 Residual Impacts

**Table 12-7 Socio-economic – Residual Impacts – Operation Phase**

Impact	Magnitude	Receptor	Sensitivity	Impact Significance	Mitigation	Residual Impact Significance
Employment creation	Moderate Positive	Employment	Medium	Moderate Positive	Yes	Moderate Positive
		Local /regional economy	Medium	Moderate Positive	Yes	Moderate Positive
Dissemination of skills	Moderate Positive	Employment	Medium	Moderate Positive	Yes	Moderate Positive
		Local /regional economy	Medium	Moderate Positive	Yes	Moderate Positive
Tourism	Minor Positive	Local /regional economy	Medium	Minor Positive	Yes	Moderate Positive
Access to Pastoralists	Minor negative	Local /regional economy	Medium	Minor negative	No	Minor negative

## 13 TRAFFIC AND TRANSPORT

### 13.1 Introduction

This chapter of the SESIA focuses on the transportation related impacts associated with the construction and operation of the NOORo II CSP. The baseline transportation infrastructure within the region and particularly within the immediate vicinity of the project is described. Consequently, the impacts from the increased traffic generated by the construction and operation phases of the project have been considered. Where necessary and possible, opportunities to pursue measures to minimise and / or mitigate any impacts have been developed and put forward.

### 13.2 Methodology

The baseline analysis of this chapter is principally desk based, drawing from the technical proposal for the project, secondary sources (transportation and local authorities) and the site visit. Once the baseline conditions are established, the impact of the development on the surrounding transport infrastructure is evaluated.

As the development will have differing impacts throughout the lifecycle of the project, we have structured our analysis to reflect the key development stages of construction and operation. The analysis in this chapter deals solely with primary transport impacts, namely

demands placed on transportation infrastructure by the development. Issues relating to secondary impacts arising from the transportation needs of the development, such as noise, are dealt with separately in the relevant chapters of this report.

### 13.3 Baseline

The site will be accessed by road for transport of materials, equipment and machinery and by workers. Ports will be used to bring equipment into the Kingdom of Morocco. Migrant workers may use the airport of Ouarzazate to access the region.

#### Port Facilities

The two closest ports to the site are Agadir and Safi, these will likely be utilised for special cargo. Casablanca provides better infrastructure for the transport of containers, whilst heavy lifts will come through the Port of Nador. Finally, the port of Tanger will be the main point of entry for shipments coming from Europe by road.

CASABLANCA HARBOUR	AGADIR HARBOUR	NADOR HARBOUR
<p><b>PORT CASABLANCA</b>  <b>Volume de trafic :</b> 9,6 millions de tonnes  <b>Volume conteneurs :</b> 600.4 EVP  <b>Spécialité :</b> trafics conteneurs, conventionnel, vracs solides et roulier  <b>Principaux produits :</b> minerais, produits sidérurgiques, sucre, bois et dérivés.  <b>Nombre de collaborateurs :</b> 1200</p>	<p><b>PORT AGADIR</b>  <b>Volume de trafic :</b> 3 millions de tonnes  <b>Volume conteneurs :</b> 127.5 EVP  <b>Spécialité :</b> trafics conteneurs, conventionnel et vracs liquides.  <b>Principaux produits :</b> Agrumes et primeurs et pois congelé.  <b>Nombre de collaborateurs :</b> 230 collaborateurs.</p>	<p><b>PORT NADOR</b>  <b>Volume de trafic :</b> 2,3 millions de tonnes  <b>Nombre passagers :</b> 598.7  <b>Spécialité :</b> trafics conventionnel et vracs solides  <b>Principaux produits :</b> charbon, billettes, barytine  <b>Nombre de collaborateurs :</b> 192</p>

### Road Network

The road network in the Province of Ouarzazate is outlined in Table 13-1

**Table 13-1 Road Network in the Province of Ouarzazate in 2007 (Km)**

National	Regional		Provincial		Other routes	
Paved	Paved	Unpaved	Paved	Unpaved	Paved	Unpaved
428	187	112	214	723	829	835

The vast majority of the plant's equipment and supplies will have go via the Agadir Ouarzazate route, as the road crossing through the Atlas mountains will not be suitable.

**Plate 13-1 Casablanca Harbour / Agadir / Ouarzazate (844 km, 9:26 minutes)**



On the approach to the site, since there is no bypass road around Ouarzazate, all traffic bringing equipment from the ports will have to cross the city. A noise baseline has been prepared for this sensitive receptor and is discussed in the noise chapter.

A newly built tarmacked road connects Tasselmant with the N10, and the access road to the site will connect to this road.

## 13.4 Sensitive Receptors

**Table 13-2 Traffic and Transport – Receptor Sensitivity**

Receptor	Sensitivity	Justification
Atlas Mountain Route to Ouarzazate	High	Narrow, single carriageway, road. No lighting, no signs and no barriers. The road has many tight curves and blind turns. Main road leading from the northern cities of Morocco to Ouarzazate.
Agadir Ouarzazate Route	Medium	As a new highway, with areas still under construction, there is a very low vehicular flow, with much capacity for future expansion.
N10 through Ouarzazate	High	The main road though the city, which also connects to all other neighbouring towns and majored cities.
Site access	Low	Dedicated road, built specifically for the site.
Ports	Low	The purpose of ports is to receive large shipments which cannot be flown in.

## 13.5 Construction Assessment

### 13.5.1 Initial Impacts

Two aspects of transport during construction can potentially generate impacts: The transport of the workforce and the transport of equipment to the site.

The major components for the construction of the plant are equipment that cannot be assembled in-situ, due to the specialised tools and machinery that is required. Therefore it has to be transported to the site. These equipment and materials will be transported in twenty and forty foot containers:

- 20 feet container: 5.9 meter long, 2.35 meter wide, 2.39 meter high
- 40 feet container: 12.32 meter long, 2.35 meter wide, 2.39 meter high
- 40 feet high cube container: 12.32 meter long, 2.35 meter wide, 2.698 meter high

The maximum weight that will be allowed for the containers is 28 tons. The containers will be transported by ships and lorries from the supplier's factories to the site in Ouarzazate. If the goods are imported to Marrocco, it will be via sea-transport.

Agadir is the first option since it is relatively close to the project site and it the required infrastructure.

The following routes will be used for bringing equipment from the ports to the site:

- Casablanca / Ouarzazate (437 Km, 4:59 minutes). This road crosses the Atlas and will be used for non-essential supplies.
- Casablanca Harbour / Agadir / Ouarzazate (844 km, 9:26 minutes). This route shall be used to transport the solar panels, HCE tubes and any other essential supplies.



- Agadir Harbour / Ouarzazate (382 km, 5 hours 9 minutes). This route shall be used by the special cargo weighing less than 80 tons.
- Nador Harbour / Ouarzazate (793 km, 10 hours 25 minutes). The most appropriate route for heavy equipment, and entry points from Europe.
- Tanger-Med Harbour / Rabat /Marrakech/Ouarzazate (822 Km, 8 hours 42 minutes). This route shall be used by trucks coming from Europe.

The dimension and origin of the containers will determine the route chosen. All of them use the N9, cross Ouarzazate and reach the access road through the N10. Therefore, construction activities are likely to lead to an increase in vehicle numbers and traffic on the N9, N10 and on the new road built for Tasselmant, until the access road is reached. Approximately 30 trucks per day during peak construction activity are expected. Experience during NOORo 1 construction has shown that the existing roads Casablanca – Ouarzazate can handle with minimum impact additional traffic demanded by the construction of the Solar Plant.

The few parts of equipment that will not fit in the containers will be transported in special platforms. Special permits will be obtained from the Moroccan authorities after an assessment of the routes that will include health, safety and environmental considerations. Similarly, all dangerous goods shall be transported following the current international standards and codes for transport of special merchandise, applying for the relevant permits with the Moroccan authorities and assessing the safety and environmental risks.

The design outlined in Figure 13-5 ensures road safety in the intersection between the site access road and the new road leading to Tasselmant.

**Plate 13-2 Access road intersection**

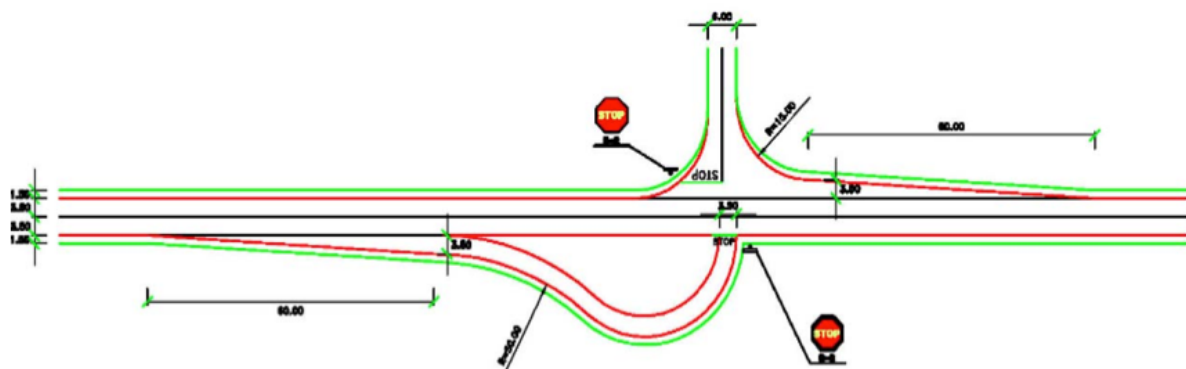

There will be a noticeable increase in Heavy Goods Vehicles (HGV) and vehicle movements for the transport of workers during construction activities. Increases in vehicle flows may cause congestion and nuisance in the N9, in the city of Ouarzazate and in the first 9 Km of

the N10. The severity of the impact will vary significantly during construction (deliveries and workers required) depending on the pace of construction. Prior to mitigation measures, this impact is considered to be of moderate negative significance.

**Table 13-3 Traffic and Transport – Magnitude of Construction Impacts**

Impact	Magnitude	Justification
Increased congestion highway	Minor	Minor direct but temporary impacts to volume and traffic flow.
Increased congestion and local roads	Moderate	Significant temporary impact on local roads generating direct (congestion) and indirect (noise, air quality) impacts on a local scale.
Movement of vehicles on the site access road	Minor	Noticeable temporary secondary impacts (e.g. noise) caused by the movement of vehicles adjacent to the site. Impacts relating to congestion are not anticipated.
Increased activity at Ports	Minor	Several ports are being used, and the number of shipments will vary with the construction schedule. Impacts are sporadic and temporary.

**Table 13-4 Traffic and Transport – Significance of Construction Impacts**

Impact	Magnitude	Receptor	Sensitivity	Impact Significance
Increased congestion highway	Minor	Atlas Mountain Route to Ouarzazate	High	Minor to Moderate
		Agadir Ouarzazate Route	Medium	Minor
Increased congestion and local roads	Moderate	N10 through Ouarzazate	High	Moderate to Major
Movement of vehicles on the site access road	Minor	Site access	Low	Negligible or Minor
Increased activity at Ports	Minor	Ports	Low	Negligible or Minor

### 13.5.2 Mitigation Measures

- To reduce the impact derived from the transport of the workforce to the site on the N10 and on Ouarzazate, worker buses shall be considered, as these will significantly reduce the number of vehicles accessing the site during construction.
- Health, safety and environmental aspect of transport of large equipment to the site shall be specifically assessed, and the required special permits shall be obtained from the Moroccan authorities.
- Any dangerous goods shall be transported following the current international standards and codes for transport of special merchandise, applying for the relevant

permits with the Moroccan authorities and assessing the safety and environmental risks.

- Wherever possible, heavy vehicle movements will be scheduled outside of peak periods and avoid times when nuisance will be higher.
- The construction vehicles leaving the site will be appropriately cleaned
- All the vehicles used in the site and leaving the site shall be appropriately maintained.
- Transport activity and frequency shall be scheduled to ensure that deliveries are timed outside of peak traffic.
- The CESMP will include a traffic management and monitoring plan, to mitigate against congestion.

### 13.5.3 Residual Impacts

**Table 13-5 Traffic and Transport – Residual Impacts – Construction Phase**

Impact	Magnitude	Receptor	Sensitivity	Impact Significance	Mitigation	Residual Impact Significance
Increased congestion highway	Minor	Atlas Mountain Route to Ouarzazate	High	Minor to Moderate	Yes	Minor
		Agadir Ouarzazate Route	Medium	Minor	Yes	Minor
Increased congestion and local roads	Moderate	N10 through Ouarzazate	High	Moderate to Major	Yes	Moderate
Movement of vehicles on the site access road	Minor	Site access	Low	Negligible to Minor	Yes	Negligible
Increased activity at Ports	Minor	Ports	Low	Negligible to Minor	Yes	Negligible

## 13.6 Operation Assessment

### 13.6.1 Initial Impacts

The relatively small workforce and the small amounts of supplies that are expected to be required in the operational phase of the plant are expected to represent an impact of negligible negative significance.

At the operational phase, the newly built access road for Tasselmant, will be used primarily by the inhabitants of this village. This impact is considered to be of minor positive significance.

**Table 13-6 Traffic and Transport – Magnitude of Operation Impacts**

Impact	Magnitude	Justification
Increased congestion highway	Negligible	Few and infrequent equipment and supplies will be transported over long distances
Increased congestion and local roads	Minor	Small permanent work force, working in shifts, will result with little increase in traffic on the local roads.
Movement of vehicles on the site access road	Negligible	Dedicate site access road only for plant vehicles.

**Table 13-7 Traffic and Transport – Significance of Operation Impacts**

Impact	Magnitude	Receptor	Sensitivity	Impact Significance
Increased congestion highway	Negligible	Atlas Mountain Route to Ouarzazate	High	Minor
		Agadir Ouarzazate Route	Medium	Negligible to Minor
Increased congestion and local roads	Minor	N10 through Ouarzazate	High	Minor to Moderate
Movement of vehicles on the site access road	Negligible	Site access	Low	Negligible to Minor

### 13.6.2 Mitigation Measures

The provision of vans for workers or incentivising car pooling schemes shall be considered during the operational phase

### 13.6.3 Residual Impacts

**Table 13-8 Traffic and Transport – Residual Impacts – Operation Phase**

Impact	Magnitude	Receptor	Sensitivity	Impact Significance	Mitigation	Residual Impact Significance
Increased congestion highway	Negligible	Atlas Mountain Route to Ouarzazate	High	Minor	No	Minor
		Agadir Ouarzazate	Medium	Negligible to Minor	No	Negligible to Minor

		Route				
Increased congestion and local roads	Minor	N10 through Ouarzazate	High	Minor to Moderate	Yes	Minor
Movement of vehicles on the site access road	Negligible	Site access	Low	Negligible to Minor	Yes	Negligible

## 14 CULTURAL HERITAGE AND ARCHAEOLOGY

### 14.1 Introduction

This chapter considers the potential cultural heritage and archaeology impacts which could potentially result during the construction phase of the proposed NOORo II Solar Power Complex.

The cultural heritage and archaeological assessment takes into account that archaeological and cultural resources are finite and therefore consideration for their preservation will always be addressed. In addition, cultural and historical sites are an important value for the tourist activities in the area.

For the purpose of this assessment, these resources may include, but not be limited to:

- Archaeological remains, buried and/or above ground;
- Historical structures and sites e.g. tombs or forts; and
- Any other structure of archaeological and/or cultural/historical significance.

Where appropriate, mitigation measures to minimise or prevent potential risks to cultural heritage and archaeology have been provided.

This chapter provides an overview of existing information and guidelines for handling artefacts or sites of cultural and archaeological significance, which will be used in the event that such artefacts are discovered during the construction phase.

### 14.2 Methodology

The assessment in this chapter has been undertaken according to the relevant local and international law, regulations and standards as described in Chapter 2.2. The assessment has included a desk-based study that included the review of the available information on the site and a site inspection.

#### Desk-Based Study

The purpose for conducting the desk-based assessment is to identify any relevant historic sites or the location of any artefacts on the site or the study area (including the presence or absence, character and extent, date, integrity, state of preservation and relative quality of the potential archaeological resource). The desk-based study consisted of the collation of existing written, graphic, photographic and electronic information in order to identify the likely character, extent, quality and worth of the known or potential archaeological resource at the site in a local, regional, national and international context.

The following information and guidance has been gathered and utilised in order to undertake the assessment:

- Data and information gathered for the FESIA;
- International Finance Corporation's Performance Standards on Social and Environmental Sustainability, (January, 2012) specifically Performance Standard 8: Cultural Heritage; and
- World Bank Environmental Safeguard Policies: Physical and Cultural Resources.
- The Equator Principles, July 2006.

### **Site Walkover**

In order to complement the information gathered during the desk-based study, a site visit was undertaken to identify the presence of any above ground archaeological structures, deposits and /or antiquities. The results and findings are discussed below.

### **14.3 Baseline**

The investigations from the FESIA concluded that no sites of historical or cultural value were found on the Ghassate commune other than sepulchral or burial sites. In addition, no evidence of archaeological value was detected on the solar complex site during the fieldwork for the FESIA.

Equally, during the site visit no artefacts or structures of cultural or archaeological significance were observed onsite. Buildings of potential historical value were identified in Tasselmant (Plate 14-1 and Plate 14-2), and a site of potential cultural/historical value was identified in one of the canyons to the northeast of the site (Plate 14-3). These structures/sites are located outside the project site and study area, and will not be affected by the project.



**Plate 14-1 Fort in Tasselmant**



**Plate 14-2 Burial site in Tasselmant**



**Plate 14-3 Area of potential archaeological interest to the northwest of the study area**



Therefore, given the lack of any materials or structures that could be used to substantiate the claim of a cultural or archaeological site, it is unlikely that the proposed project plot contains any resources of cultural or archaeological value.

**14.4 Sensitive Receptors**

The table below outlines the identified receptors in relation to cultural heritage and archaeology as well as the determined sensitivity of those receptors.

**Table 14-1 Culture and Archaeology - Receptors sensitivity**

Receptor	Sensitivity	Justification
Potentially unidentified archaeological sites	Low	There is no evidence of any archaeological sites onsite. The topography of the area and the soil type makes archaeological findings in the plateau highly unlikely.

**14.5 Construction Assessment**

**14.5.1 Initial Impacts**

For the reasons outlined in the baseline, it is considered unlikely that potential impacts of cultural or archaeological value will occur during the construction phase.

In the event that earthworks during the construction phase uncover unidentified sources of archaeological or cultural heritage, this will result in an impact of major negative significance prior to the implementation of mitigation measures.

**Table 14-2 Culture and Archaeology – Magnitude of Construction Impacts**

Impact	Magnitude	Justification
Destruction of unknown archaeological remains onsite	Major	Construction activities could cause the destruction of archaeological remains onsite, resulting in permanent losses of the archaeological features.

**Table 14-3 Culture and Archaeology – Significance of Construction Impacts**

Impact	Magnitude	Receptor	Sensitivity	Impact Significance
Destruction of unknown archaeological remains onsite	Major	Potentially unidentified archaeological sites	Low	Moderate

#### 14.5.2 Mitigation Measures

The EPC contractor will be required to prepare a CESMP before commencing construction works, which will consider the potential for unearthing historical sites or artefacts.

The EPC will also be required to follow and consider the Standards and Guidelines for an Archaeological Watching Brief, Institute of Field Archaeologists, Revised Version, 2008. The Archaeological Watching Brief is a formal programme of observations and investigations that are carried out for non-archaeological projects. It can be undertaken in any site where possibilities to find any archaeological deposits exist.

Training and awareness programmes will be provided to ensure that construction staff and labourers are aware of the procedures relating to the Archaeological Watching Brief will any artefacts or anthropogenic finds be uncovered. In the unlikely event of any artefacts being found/uncovered, the construction work would be ceased immediately and the Minister of Culture, via the “*Institut National des Sciences de L’Archéologie et du Patrimoine (INSAP)*” will be contacted by the contractor the Site Manager. The INSAP will take charge of any archaeological investigations.

#### 14.5.3 Residual Impacts

Given that no evidence of sites of historical or archaeological value has been observed in the area, the risk of uncovering any archaeological resources is considered very low. Equally,

the implementation of the above mitigation procedures will help minimise any impact that may occur to an acceptable level.

**Table 14-4 Culture and Archaeology – Residual Impacts – Construction Phase**

Impact	Magnitude	Receptor	Sensitivity	Impact Significance	Mitigation	Residual Impact Significance
Destruction of unknown archaeological remains onsite	Major	Potentially unidentified archaeological sites	Low	Moderate	Yes	Negligible

## 14.6 Operation Assessment

### 14.6.1 Initial Impacts

It is not considered that any significant impacts upon archaeological or cultural resources will occur during the operational phase.

**Table 14-5 Culture and Archaeology – Magnitude of Operation Impacts**

Impact	Magnitude	Justification
Destruction of unknown archaeological remains onsite	No Change	Major earthworks will not be conducted during the operation phase and as such will not result in the damage/destruction of archaeological remains onsite.

**Table 14-6 Culture and Archaeology – Significance of Operation Impacts**

Impact	Magnitude	Receptor	Sensitivity	Impact Significance
Destruction of unknown archaeological remains onsite	No Change	Potentially unidentified archaeological sites	Low	Neutral

### 14.6.2 Mitigation Measures

Should further excavation on the site be required, the mitigation measures mentioned previously for the construction phase will be followed.

### 14.6.3 Residual Impacts

**Table 14-7 Culture and Archaeology – Residual Impacts – Operation Phase**



Impact	Magnitude	Receptor	Sensitivity	Impact Significance	Mitigation	Residual Impact Significance
Destruction of unknown archaeological remains onsite	No Change	Potentially unidentified archaeological sites	Low	Neutral	N/A	Neutral

## 15 LANDSCAPE AND VISUAL IMPACT

### 15.1 Introduction

Impacts upon the landscape typically occur in situations where the visual horizon is disturbed by a development. Such impacts may include the anthropogenic intrusion of the landscape by buildings/structures where no intrusion previously existed; or the change in the landscape character of an area, which could arise from new/out of place development or from changes in the land use.

Visual impacts may occur when the line of sight to and/or from a receptor (e.g. residential areas, area of natural beauty) is intersected or blocked.

Visual and landscape impacts are relevant to this project, since tourism is a relevant economic activity in the area and the quality of the natural landscape is one of its assets.

### 15.2 Methodology

The assessment of the Project upon the landscape and visual amenity of the surrounding area has been informed by the following:

- Desk-based assessment of existing information available, including maps, site plans and viewpoint photographs taken at various locations;
- Site survey undertaken to identify the existing landscape and visual character of the area.

### 15.3 Baseline

The proposed NOORo II Power Plant site will be located on a rocky plateau, crossed by chaabas and surrounded by canyons, which are characteristic of this part of the Atlas Mountains. There are no anthropogenic elements on the site other than the NOORo I CSP currently under construction, the water storage station and the newly built tarmac road connecting the Village of Tasselmant to the N10 and the power plant sites.

At the intersection of the N10 and the newly built road for Tasselmant, there are two telecommunication antennas that create a vertical intrusion to the landscape.

The nearby villages and the city of Ouarzazate are built following the chromatic pattern of the natural landscape. For this reason, they form a natural-cultural landscape that has a high intrinsic and touristic value.

### **The Site and Surrounding Area**

This chapter presents a number of photos that have been taken on and surrounding the proposed NOORo II CSP, to provide an indication of the landscape and visual characteristics.

#### **Plate 15-1 Communication towers at the intersection of N10 and the site access road**





**Plate 15-2 Typical view of the site**

#### **15.4 Sensitive Receptors**

The closest relevant landscape and visual receptors to the proposed NOORo II site are the villages of Tasselmant Tiflile, Igherm Amellal, Tidgheste, Taferghouste to the East and the city of Ouarzazate, that is located 8 km south west of the site.

Both the N10 road, located 5Km south of the project site, and the new road that was built for the village of Tasselmant and for site access may potentially represent a sensitive receptor and the visual amenity to road users. However, NOORo II is likely to be screened from the N10 by the topography and by NOORo 1.

The table below outlines the identified receptors in relation to landscape and visual impacts as well as the determined sensitivity of those receptors.

**Table 15-1 Landscape and Visual – Receptor Sensitivity**

Receptor	Sensitivity	Justification
Landscape Character	Medium	There are no specific landscape designations or other outstanding features present to make the landscape character of this particular area unique. However, tourism is an important economic activity in the area and the landscape is one of the tourists assets of the region.
Existing Visual Receptors	Medium	The villages are located in the Oueds, therefore they are at a lower elevation with respect to the site. Residents would not be able to see the solar panels, however while driving from a short stretch the N10 to the villages, the solar field would be visible.

## 15.5 Construction Assessment

### 15.5.1 Initial Impacts

During the construction of the NOORo II CSP, several buildings will be temporarily located on site, including offices and material storage. Equally a variety of construction vehicles will be travelling to and from the project site, these will include trailers, cement trucks, graders, excavators, loaders, water trucks, waste removal trucks...etc. Finally, some construction materials and equipment will be located on site during the entire construction program and these will include cranes, pile drivers and drilling machines.

At certain stages during the construction phase, some night-time works may take place which will likely require floodlighting. If not mitigated, this could have a minor negative impact on local road users.

The view to the SPC from the villages to the east and northeast and from Ouarzazate is blocked by the topography of the area (i.e. the topographic configuration of the plateau and the hills present in the area). Therefore the landscape and visual impact from those sensitive receptors is considered to be minor.

The site will be visible from a short length (approximately 5Km) of the N10 road and from the access road to Tasselmant. In this area there are already anthropogenic elements, in particular two telecommunication antennas. This is considered to be a minor negative impact.

**Table 15-2 Landscape and Visual – Magnitude of Construction Impacts**

Impact	Magnitude	Justification
Topographical impacts to landscape	Negligible	No significant changes to the topography are anticipated.
New features in the landscape	Minor	New features in the landscape will partially impact the landscape character, however they will not adversely affect the integrity of it in respect to the surrounding area.
New features impacting views	Minor	New features will partially impact views from receptors, however they will not result in total losses of key views from receptors.
Light Pollution	Minor	Construction flood lights will increase the illumination in the area, although the background lighting is already high

**Table 15-3 Landscape and Visual – Significance of Construction Impacts**

Impact	Magnitude	Receptor	Sensitivity	Impact Significance
Topographical impacts to landscape	Negligible	Landscape Character	Medium	Negligible to Minor
New features in the landscape	Minor	Landscape Character	Medium	Minor
New features impacting views	Minor	Visual Impacts	Medium	Minor
Light Pollution	Minor	Visual Impacts	Medium	Minor

### 15.5.2 Mitigation Measures

Construction traffic to the site will be minimised through effective transportation planning, combining loads and utilising non-peak timing where possible.

Any flood lights required during night time construction activities will be directed onto the site, with a maximum position angle of 30° from vertical, therefore minimising any potential light leakage and impacts at night.

### 15.5.3 Residual Impacts

**Table 15-4 Landscape and Visual – Residual Impacts – Construction Phase**

Impact	Magnitude	Receptor	Sensitivity	Impact Significance	Mitigation	Residual Impact Significance
Topographical impacts to landscape	Negligible	Landscape Character	Medium	Negligible to Minor	No	Negligible to Minor

New features in the landscape	Minor	Landscape Character	Medium	Minor	No	Minor
New features impacting views	Minor	Visual Impacts	Medium	Minor	No	Minor
Light Pollution	Minor	Visual Impacts	Medium	Minor	Yes	Negligible

## 15.6 Operation Assessment

### 15.6.1 Initial Impacts

The proposed Project design includes the construction of two 22m high stacks. These will be the highest permanent structures of the NOORo II CSP. However, given the topography of the area and considering that these structures will be located in the power island, they will be screened from view from the nearby villages and from Ouarzazate. These structures, together with parabolic mirrors located in the east boundary of the site and the site's fence will be visible from the access road to Tasselmant. The ancillary structures (water inlet, power output) will also be visible from these roads.

The design of the NOORo II CSP is very similar to the design of the NOORo I CSP, given that the NOORo I plant is located immediately to the south of the project, the cumulative visual impact of two large solar fields is considered minor negative significance.

**Table 15-5 Landscape and Visual – Magnitude of Operation Impacts**

Impact	Magnitude	Justification
Influence on Landscape Character Use	Minor	The proposed facility will be immediately adjacent to the NOORo I plant and will therefore result with a cumulative impact on the landscape character.
Impact upon Visual Amenity of Receptors	Minor	The site will be visible from the road to Tasselmant. However, no tall structures will be visible. The predominant view will be an even surface of reflectors.
Night Time Lights	Minor	The additional lighting of NOORo II to NOORo I, will have a cumulative impact on the sensitive receptors.

**Table 15-6 Landscape and Visual – Significance of Operation Impacts**

Impact	Magnitude	Receptor	Sensitivity	Impact Significance
Influence on Landscape Character Use	Minor	Landscape Character	Low	Negligible to Minor
Impact upon Visual Amenity of Receptors	Minor	Visual Impacts	Medium	Minor
Night Time Light	Minor	Visual Impacts	Medium	Minor

### 15.6.2 Mitigation Measures

No mitigation measures are available to reduce the visual impact of the structures that will be required for the plant. The measures designed for vegetation restoration and compensation include re-vegetation at the bottom of canyons, to provide compensation for the lost habitat and reduce soil erosion, and will therefore not screen the structures built onsite. It is not considered beneficial from an ecological or from a water management perspective to implement a landscaping programme to plant alien species of vegetation within the site or at the project boundary that could screen the visual impact from the project, as attracting birds to the site could result in more avian deaths.

### 15.6.3 Residual Impacts

**Table 15-7 Landscape and Visual – Residual Impacts – Operation Phase**

Impact	Magnitude	Receptor	Sensitivity	Impact Significance	Mitigation	Residual Impact Significance
Influence on Landscape Character Use	Minor	Landscape Character	Low	Negligible to Minor	No	Negligible to Minor
Impact upon Visual Amenity of Receptors	Minor	Visual Impacts	Medium	Minor	No	Minor
Night Time Light	Minor	Visual Impacts	Medium	Minor	No	Minor

## 16 REFERENCES

- Agence de développement agricole (2008) Plan agricole de la Région: *Souss-Massa-Draa*.
- BAD Ouarzazate Solar Power Station, P-MA-DC0-003. Résumé EIES.
- Calvert, A. M., C. A. Bishop, R. D. Elliot, E. A. Krebs, T. M. Kydd, C. S. Machtans, and G. J. Robertson (2013) A synthesis of human-related avian mortality in Canada. *Avian Conservation and Ecology*. Environment Canada
- Conseil Régional Souss Massa Drâa, *Stratégie Région Souss Massa Drâa 2011-2015*.
- Centre Régional d'Investissement Souss Massa Draa (2006) *Observatoire de l'Investissement régional*.
- Centre Régional d'Investissement Souss Massa Draa (2009) *Observatoire de l'Investissement régional*.
- Centre Régional d'Investissement - Souss Massa Drâa *Fiche Projet Transport*. Royaume du Maroc, Ministère de l'Intérieur, Wilaya de la Région Souss Massa Drâa.
- Énergie propre des déserts (2009) *Le concept DESERTEC appliqué à l'énergie, l'eau et la sécurité climatique Whitebook*.
- Direction Régionale de l'ONEP - Ouarzazate, *Fiche technique du barrage Mansour Ed dahb*.
- Conseil de la Région Souss Massa Draâ (2011) *Projet Intégré d'énergie électrique solaire d'une capacité de 2000 MW*.
- Conseil de la Région Souss Massa Draâ (2011) Spécial: *Stratégie de Développement économique et social de la région Souss Massa Draâ*.
- Direction Générale des Collectivité Locales - Agence du Développement Social (2009) *Initiative Nationale pour le Développement Humain - Diagnostic territorial: Participatif de la commune rurale de Ghassate*.
- Perspective des technologies d'énergie (2008) - *Scénarios et stratégies à l'horizon de 2050* - Agence Internationale de l'Energie.
- Institut de Recherches Agronomiques - Maroc (2000) *Esquisse préliminaire de la carte des sols du Maroc*, digitalisée pour la FESIA.
- Institutions financières internationales (2012) *Normes de performance et des notes d'orientation*. IFC - Groupe de la Banque mondiale.
- Institutions financières internationales (2012) *les directives de l'environnement, de la santé, et de la sécurité*. IFC - Groupe de la Banque mondiale.
- Karen Rignall (2012) *Théoriser la souveraineté en terrain vide: les implications foncières de l'énergie solaire concentrée dans la région présaharienne du Maroc*, Document présenté à la Conférence



internationale sur l'accaparement des terres dans le monde II, octobre 17-19, 2012 Organisée par Land Deals Politics Initiative (LDPI) et accueillie par le ministère du Développement sociologie à l'Université Cornell, Ithaca, NY.

MASEN (2010) *Etude hydraulique et hydrologique du complexe énergétique solaire de Ouarzazate.*

MASEN / Phenixa / Burgeap (2011) *Ouarzazate FESIA Complexe Solaire d'Ouarzazate.*

Ministère de l'Industrie, du Commerce et des Nouvelles Technologies (2009) *Pacte National pour l'émergence industrielle.*

Ministère de l'Aménagement du Territoire, de l'Urbanisme, de l'Habitat et de l'Environnement; Direction de l'Aménagement du Territoire., *Carte de sismicité du Maroc (1901-1998) dans Fenêtre sur le Territoire Marocain*

Oscar Reyes, *l'énergie solaire marocaine et le Grab énergétique de l'UE*, World Development Movement.

Région Souss Massa Drâa, *Le Conseil Régional de Souss Massa Draa, stratégie du royaume du Maroc*, Ministère de l'Intérieur, région Souss Massa Drâa

Royaume du Maroc (2009) *Présentation du Projet Solaire Marocain*

Turchi, C.S., Wagner, M.J., and Kutscher C.F., (2010) *Water Use in Parabolic Trough Power Plants: Summary Results from WorleyParsons' Analyses.* NREL, U.S. Department of Energy, Office of Energy Efficiency & Renewable Energy

Wallace P. Erickson, Gregory D. Johnson, and David P. Young Jr.2 (2005) *A Summary and Comparison of Bird Mortality from Anthropogenic Causes with an Emphasis on Collisions* USDA Forest Service Gen. Tech. Rep. PSW-GTR-191. 2005

The following references were used in the ecological survey undertaken for the FESIA, that has been used as a baseline (with a validation survey) for the SESIA:

ADMINISTRATION DES EAUX ET FORÊTS ET DE LA CONSERVATION DES SOLS, 1995. *Projet de plan d'Etude et Gestion des Aires Protégées du Maroc. Tome 1: Plan directeur des Aires Protégées du Maroc. Volume n ° 1: Les Écosystèmes et marocains situation de la de la flore et de la faune.* Ministère de l'Agriculture et de la Mise en valeur agricole / BAD / BCEOM-SECA,

ADMINISTRATION DES EAUX ET FORÊTS ET DE LA CONSERVATION DES SOLS, 1995. *Projet de plan d'Etude et Gestion des Aires Protégées du Maroc. Tome 1: Plan directeur des Aires Protégées du Maroc. Volume n ° 2: Les sites de d'Intérêt biologique et écologique du continent domaine.* Ministère de l'Agriculture et de la Mise en valeur agricole / BAD / BCEOM-SECA, 412 p;

AULAGNIER S. & M. Thévenot, 1986. *Catalogue des Mammifères sauvages du Maroc.* Trav. Inst. Sci., Ser. zool., n ° 42. Rabat. 164 p;

- BONS J. & P. GENIEZ, 1996. Amphibiens Reptiles et du Maroc (Sahara occidental compris). Atlas biogéographique. Asociacion Herpetologica Española, Barcelone. 320 p;
- CUZIN F., 2003. Les grands Mammifères du Maroc méridional (Haut Atlas, Anti-Atlas, Sahara). Répartition, écologie et la conservation. Thèse Doctorat, EPHE, Montpellier II, Montpellier. 348P;
- CUZIN F., A. & M. BENABID El Youssofi, 2005. Inventaire Participatif, d'identification et Evaluation des sites de clé de la Biodiversité. CBTHA, 234 p;
- CUZIN, F., SEHHAR, É.A., et Wachter, T. (2007). Etude pour l'élaboration de lignes directrices et d'ONU Plan d'Action stratégique pour la conservation des ongulés au Maroc. Haut Commissariat aux Eaux et Forêts et à la Lutte Contre la Désertification (HCEFLCD),
- Projet de Gestion des Aires Protégées (PGAP), la Banque Mondiale, Fonds pour l'environnement mondial (FEM);
- DAKKI M. & E. A. SEHHAR, 2003. Diagnostic for the Gestion durable des zones humides du Mgoun-Dades. Projet de "Conservation de la Biodiversité par la Transhumance In the Versant sud du Haut Atlas", ORMVAO, Ouarzazate. 80 p;
- DANET P., 2006. Les oiseaux de Ouarzazate au début des années 1980. Allez-Sud Bull. , 3: 18-27;
- FENNANE M. & M. IBN Tattou, 1998. Catalogue des plantes vasculaires rares, menaces ou endémiques du Maroc. Bocconeia, 243 p. ;
- FENNANE, M., IBN Tattou, M., MATHEZ, J., Ouyahya, A., & El OUALIDI, J. (1999) Flore pratique du Maroc. Manuel de la détermination des plantes vasculaires. Ptéridophytes, gymnospermes, angiospermes (Lauraceae-Neuradaceae), Rabat;
- FENNANE, M., IBN Tattou, M. Ouyahya, A., & El OUALIDI, J. (2007) Flore pratique du Maroc. Manuel de la détermination des plantes vasculaires. Angiospermes (Légumineuses - Lentibulariaceae), Rabat;
- L'UICN Species Survival Commission, 2010. 2010, liste rouge des espèces menacées.
- MINISTERE DE L'AGRICULTURE DU DEVELOPPEMENT RURAL ET DES PECHES MARITIMES (2008). Plan de cadres de Gestion de la Réserve de biosphère des Oasis du Sud Marocain (RBOSM). Volume I - Rapports Rabat principale. 459p.;
- SCHWEIGER, M. (1992) Herpetologische Beobachtungen Ouarzazate (Marokko). Observations herpétologiques dans la région de Ouarzazate (Maroc). Herpetozoa, 5, 13-31;
- Thévenot M., R. & P. BERGIER VERNON, 2003. Les oiseaux du Maroc. Une liste annotée. Série Liste BOU, n ° 20. Tring, Hertfordshire (Royaume-Uni). 594 p.