

Updated Initial Environmental Examination

Project number: 35173-013
July 2015

NEP: Third Small Towns Water Supply and Sanitation Sector Project —Ghorahi (Dang District)

Prepared by ITECO Nepal (P) Ltd., SILT Consultants (P) Ltd., and Unique Engineering Consultancy (P) Ltd. for the Government of Nepal and the Asian Development Bank.

This revised initial environmental examination report is a document of the borrower. The views expressed herein do not necessarily represent those of ADB's Board of Directors, Management, or staff, and may be preliminary in nature.

In preparing any country program or strategy, financing any project, or by making any designation of or reference to a particular territory or geographic area in this document, the Asian Development Bank does not intend to make any judgments as to the legal or other status of any territory or area.



Government of Nepal
Ministry of Water Supply and Sanitation
Department of Water Supply and Sewerage
Small Towns Water Supply and Sanitation Sector Project (STWSSSP)
Project Management Office (PMO)
Panipokhari, Maharajgunj, Kathmandu, Nepal



**Enhance Functionality in Small Towns Water Supply and Sanitation
Sector Project (STWSSSP)**

Updated Initial Environmental Examination Report (IEE)

for

**Ghorahi Small Towns Water Supply and Sanitation Sector Project
Dang District**



Kathmandu, July 2015

Submitted by:

Joint Venture in Between



ITECO Nepal (P) Ltd.

P. O. Box 2147

Min Bhawan, Kathmandu, Nepal

Tel: ++977-1- 46 21 764 (Hunting Line),

Fax : ++ 977-1- 46 22 298

E-mail: iteco@mos.com.np

Website: www.iteconepal.com



SILT Consultants (P) Ltd.

P.O. Box 2724

Ratopul, Gaushala, Kathmandu, Nepal

Tel: ++977-1-44 87 598, 44 75139

Fax: ++977-1-44 73 573

E-mail: silt@mos.com.np, info@silt.com.np

Website: www.silt.com.np



**Unique Engineering
Consultancy (P) Ltd.**

P. O. Box 3522, Jwagal-10, Lalitpur, Nepal

Tel: ++977-1-55 49 332, 55 29 896

Fax: ++977-1-55 49 332

E-mail: unecnepal@gmail.com

Website: www.unecnepal.com.np

Table of Contents

EXECUTIVE SUMMARY	8
1. INTRODUCTION	8
1.1 Background.....	8
1.2 Objectives of IEE	8
1.3 Rational of IEE Requirement.....	8
2. POLICY, LEGAL & ADMINISTRATIVE FRAMEWORK	9
2.1 ADB Policy	9
2.2 ADB Safeguards policy	9
2.3 Nepal’s Environmental Policy and Legal Framework.....	12
3. ANALYSIS OF ALTERNATIVES	17
3.1 Alternatives considered in the approved IEE report 2006.....	17
3.1.1 No Action	17
3.1.2 Alternative Sources of Water Supply	17
3.1.3 Choice of Technology.....	17
3.1.4 Water Supply Service Levels.....	17
3.1.5 Sanitation	18
3.1.6 Period of Construction.....	18
3.1.7 Choice of Alternative	18
3.2 Alternatives for the Updated IEE	18
4. DESCRIPTION OF SUBPROJECT	19
4.1 The Study Area.....	19
4.2 Existing Condition and Need for the Subproject	21
4.2.1 General Information.....	21
4.2.2 Technical Information Component.....	21
4.2.3 Socio- Economic Information.....	21
4.2.4 Financial Information	22
4.3 Sub Project Construction Schedule.....	22
5. DESCRIPTION OF THE ENVIRONMENT	24
5.1 Physical Profile	24
5.1.1 Topography.....	24
5.1.2 Geology and Soils	24
5.1.3 Climate.....	24
5.1.4 Surface and Groundwater	24
5.1.5 Flora.....	25
5.1.6 Fauna.....	25
5.1.7 Protected Areas	25
5.1.8 Water Quality Analysis	25
5.2 Socio Economic Condition	26
5.2.1 Population, Communities and Occupation.....	26
5.2.2 Health and Sanitation	26
5.2.3 Economic Characteristics	26
5.2.4 Infrastructure Facilities	27
5.2.5 Land Use Planning	27
5.2.6 Quality of Life Values	27
5.3 Resettlement, Relocation and Compensation Issue	27
6. DESCRIPTION OF IMPACT ASSESSMENT	28
6.1 Physical Environment	28
6.1.1 Impact on Land Use Pattern.....	28

6.1.2	Flooding and Stagnant Water Problem.....	28
6.1.3	Impact on Water/Land Quality	28
6.1.4	Impacts of sediments and Disinfecting Chemicals.....	28
6.1.5	Water Volume/Quality	28
6.2	Biological Environment.....	28
6.2.1	Impact on Natural Vegetation and Ecology.....	28
6.2.2	Impact on Aquatic Life.....	28
6.2.3	Loss of Habitat	28
6.2.4	Impacts on Air Quality	28
6.2.5	Impacts on Acoustic Environment	29
6.2.6	Impacts on Traffic and Temporary disturbance.....	29
6.3	Socio-Economic and Cultural Environment	29
6.3.1	Land Acquisition.....	29
6.3.2	Outside Workforce Conflict/Health/Pollution/Culture.....	29
6.3.3	Workers' Health and Safety Hazards.....	29
6.3.4	Water Right Conflict	29
6.4	Beneficial impacts.....	29
7.	DESCRIPTION OF MITIGATION MEASURES	30
7.1	Physical Environment	30
7.1.1	Impact on Land Use Pattern.....	30
7.1.2	Flooding and Stagnant Water Problem.....	30
7.1.3	Water/land quality.....	30
7.1.4	Impacts of Sediments and Disinfecting Chemicals	30
7.1.5	Water Volume	30
7.1.6	Impacts on Air Quality	30
7.1.7	Impacts on Acoustic Environment	30
7.1.8	Traffic and Temporary disturbance.....	31
7.2	Biological Environment.....	31
7.2.1	Impact on Natural Vegetation And Habitat.....	31
7.3	Socio-economic and Cultural Environment.....	31
7.3.1	Land Acquisition.....	31
7.3.2	Outside Workforce Conflict/Health/Pollution/Culture.....	31
7.3.3	Workers' Health and Safety Hazards.....	31
7.3.4	Water right Conflict.....	31
7.4	Activities for Rehabilitation Work and its Mitigation Measures	32
8.	INFORMATION DISCLOSURE, CONSULTATION AND PARTICIPATION	36
8.1	Consultation.....	36
8.2	Initial consultation: the existing project.....	36
8.3	The consultation during IEE update	36
8.3.1	Phase I.....	36
8.3.2	Phase II.....	37
8.4	Costs	37
9.	GRIEVANCE REDRESS MECHANISM	38
9.1	Purpose of the Grievance Redress Mechanism	38
9.1.1	First Level of GRM (WUSC-level).....	38
9.1.2	Second Level of GRM (VDC/Municipality level).....	39
9.1.3	Third Level of GRM (PMO Level)	39
10.	ENVIRONMENT MANAGEMENT PLAN.....	41
10.1	Institutional Arrangement	41
10.1.1	Safeguard Implementation Arrangement.....	41
10.1.2	Institutional Capacity Development Program.....	43
10.1.3	Staffing Requirement and Budget.....	44

10.2	Monitoring and Reporting.....	44
10.3	Environmental Monitoring Mechanism	44
10.4	Monitoring Reporting Mechanism.....	44
10.5	Monitoring Cost, Parameters, Location and Schedule.....	45
10.6	Contractors Compliance on EMP	45
10.7	Institutional Capacity Development Program.....	45
10.8	Environmental Mitigation Cost.....	45
11.	CONCLUSIONS AND RECOMMENDATIONS	51
12.	COMMENTS INCORPORATION MATRIX	52

List of Tables

Table 2-1:	ADB SPS, 2009 Safeguard Requirements 1: Environment	9
Table 2-2:	Other Relevant Environmental and Core Labor Policies, Laws and Guidelines of Nepal Applicable to the Subproject,	13
Table 7-1:	Activities for Rehabilitation Work.....	33
Table 8-1:	Lists of People and Institutions Consulted.....	36
Table 10-1:	Mitigation measures and corresponding Monitoring plan	46
Table 10-2:	Mitigation Measures and Monitoring Plan for Rehabilitation Activities	49

List of Figures

Figure 4-1:	Location of the Subproject Area.....	20
Figure 4-2:	Construction Schedule.....	23

Annexes

- Annex 1:** Project Location Map and Water Supply Plan
- Annex 2:** Water Tested Laboratory Analysis Report
- Annex 3:** Rapid Environment Assessment (REA) Checklist
- Annex 4:** Minute of Meeting

Abbreviations

°C	: Degree Centigrade
ADB	: Asian Development Bank
CBD	: Convention of Biological Diversity
CITES	: Convention on International Trade in Endangered Species of wild Fauna and Flora
cum	: Cubic Meter
WSSDO	: Water Supply and Sanitation Division Office
DWSS	: Department of water Supply and Sewerage
EA	: Environmental Assessment
EIA	: Environmental Impact Assessment
EMP	: Environmental Management Plan
EPA	: Environmental Protection Act
EPR	: Environment Protection Regulations
HHE	: Health and Hygiene Education Programs
HMG/N	: His Majesty's Government of Nepal
HRF	: Horizontal Roughing Filter
IEE	: Initial Environmental Examination
JICA	: Japanese International Cooperation Agency
km	: Kilometer
GWSSSP	: Ghorahi Water Supply and Sanitation Sub-Project
LGs	: Local Governments
lpd	: Liter per day
lps	: Liter per second
m	: Meter
MDG	: Millennium Development Goals
MOWR	: Ministry of Water Resources
MPPH	: Ministry of Physical Planning and Housing
MoWSS	: Ministry of Water Supply and Sanitation
MoSTE	: Ministry of Science, Technology and Environment
NGO	: Non-Government Organization
NDWQS	: National Drinking Water Quality Standard
NPC	: National Planning Commission
NRs.	: Nepalese Rupees
O&M	: Operation and Maintenance
PAC	: Public Awareness Campaign
PCO	: Public Call Office
PF	: Pressure Filter
Pop.	: Population
PRA	: Participatory Rural Appraisal
PMO	: Project Management Office
RRA	: Rapid Rural Appraisal
SPSO	: Sub-Project Site Office
SSF	: Slow Sand Filter
SPS	: Safeguard Policy Statement
STWSSSP	: Small Town Water Supply and Sanitation Sector Project
TDF	: Town Development Fund
VDC	: Village Development Committee
WHO	: World Health Organization
WSUC	: Water Supply Users' Committee
WUSC	: Water Users and Sanitation Committee

EXECUTIVE SUMMARY

General

The Enhance Functionality in Small Towns Water Supply and Sanitation Sector Project (STWSSSP) will support the government of Nepal (the Government) in improving water supply and sanitation facilities and services to 24 small towns in Nepal. Out of the 265 small towns in Nepal, Asian Development Bank (ADB) has already supported the Government, through successful implementation of earlier two projects in 50 towns. These include the 24 project for enhancement.

The outcome will be inclusive and sustainable water supply and sanitation service delivery in this Ghorahi small town of Nepal. The project will implement improvements/ rehabilitation works within the service area of already completed project. There will be minor civil works necessary for the enhancement of the components without changing the original technical and social concepts.

The Project will be implemented in 12 months period starting around first week of November, 2015.

The project will be funded by a loan using a sector lending approach of ADB. The Executing Agency is the Ministry of Water Supply and Sanitation and the implementing agency is the Department of Water Supply and Sewerage (DWSS).

The sub project IEE report was approved by government of Nepal in 2005. Now the sub project is envisaged to undergo for rehabilitation of project components such as, intake treatment plant, transmission main and distribution line etc. The proposed updated IEE is prepared as an integral part of bid document. However consultant has updated the contents of IEE report already approved from government of Nepal.

This updated IEE Report summarizes anticipated impacts and corresponding mitigation measures, monitoring and also includes cost and time frame for implementation.

In this report, all the policy, legal and administrative framework requirements of ADB including ADB Safeguard Policy and the prevailing GoN Acts/rules & regulations have been considered.

Categorization

Ghorahi town subproject is classified as Environmental Category B as per the SPS as no significant impacts are envisioned. Accordingly this updated Initial Environmental Examination (IEE) has been prepared and assesses the environmental impacts and provides mitigation and monitoring measures to ensure no significant impacts as a result of the subproject.

Subproject Scope

The subproject is formulated under the 3STWSSSP to improve water supply and sanitation service delivery in the existing Ghorahi water supply and sanitation project constructed during STWSSP 1. Investments under this subproject includes; (i) rehabilitation of a piped water supply system including intake, water treatment plant, transmission main, and distribution main.

Implementation Arrangements

The Ministry of Water Supply and Sanitation is the executing agency. The Department of Water Supply and Sewerage (DWSS) is the implementing agency. Implementation activities will be overseen by a separate Project Management Office (PMO) which will be established in DWSS head office in Kathmandu and two Regional Project Management Offices (RPMOs) in the eastern and western region. A team of technical, administrative and financial officials, including safeguards specialists, will be provided at the PMO to implement, manage and monitor project implementation activities. The RPMOs will be staffed by qualified and experienced officers and will be responsible for the day-to-day activities of project implementation in the field, and will be under the direct administrative control of the PMO. Consultant teams are responsible for subproject planning and management and assuring technical quality of design and construction; and designing the infrastructure and supervising construction; and safeguards preparation.

Description of the Environment

Subproject components are located in Ghorahi town area and in its immediate surroundings. There is no presence of natural habitat in this project area. The project components will be located in WUSC sites, public road rights-of-way (ROW) and outside the community managed forest and the

protected areas. There are no protected areas, wetlands, mangroves, or estuaries in or near the subproject locations.

Environmental Management

An environmental management plan (EMP) is included as part of this IEE, which includes (i) mitigation measures for environmental impacts during implementation; (ii) an environmental monitoring program, and the responsible entities for mitigating, monitoring, and reporting; (iii) public consultation and information disclosure; and (iv) a grievance redress mechanism. A number of impacts and their significance have already been reduced by amending the designs. The EMP will be included in civil work bidding and contract documents.

Locations and sitting of the infrastructures were considered in the existing sub-project to further reduce impacts. The concepts considered in design of the subproject are: (i) demand for new piped water supply; (ii) maximum population coverage with pipe layout mostly in residential areas and areas of high growth rate; (iii) avoidance of water-use conflicts; (iv) locating pipelines within ROWs to reduce acquisition of land; (v) locating pipelines at least 10 meters from latrines, septic tanks and any main drains to avoid contamination; (vi) locating Intake point 30 m upstream from sanitation facilities; (vii) locating household and public latrines and septic tanks at least 30 meters downstream from the nearest drinking water source; (viii) piloting controlled disposal of septage in accordance to WHO and US EPA standards to reduce the likelihood of uncontrolled disposal as currently practiced; and (ix) ensuring all planning and design interventions and decisions were made in consultation with local communities and reflecting inputs from public consultation and disclosure for site selection.

During the construction phase, impacts mainly arise from the need to dispose of moderate quantities of waste soil; and from the disturbance of residents, businesses, and traffic. These are common impacts of construction in urban areas, and there are well developed methods for their mitigation. Measures such as conducting work in lean season and minimizing inconvenience by best construction methods will be employed. Traffic management will be necessary during pipe-laying on busy roads. In the operational phase, all facilities and infrastructure will operate with routine maintenance, which should not affect the environment. Facilities will need to be repaired from time to time, but environmental impacts will be much less than those of the construction period as the work will be infrequent, affecting small areas only.

Mitigation measures

Mitigation measures have been developed to reduce all negative impacts to acceptable levels. Mitigation will be assured by a program of environmental monitoring to be conducted during construction. The environmental monitoring program will ensure that all measures are implemented, and will determine whether the environment is protected as intended. It will include observations on- and off-site, document checks, and interviews with workers and beneficiaries. Any requirements for corrective action will be reported to the ADB.

The stakeholders were involved in developing the IEE through discussions on-site and public consultation, after which views expressed were incorporated into the IEE and in the planning and development of the subproject. The IEE will be made available at public locations in the town and will be disclosed to a wider audience via the ADB and DWSS websites. The consultation process will be continued and expanded during project implementation to ensure that stakeholders are fully engaged in the project and have the opportunity to participate in its development and implementation.

The core service area is the market area and mostly located in Ward nos. 10 and 11. Other parts of the service area are mostly semi-urban type. The settlement pattern in core service area (Bazaar area) is dense, whereas in other adjoining parts of the service area the settlement pattern ranges from moderately dense to scattered.

The sub-project under construction is a rehabilitation project and the mitigation measures recommended in the approved IEE in 2006 have already been successfully implemented. During the updated IEE preparation process, all of the process mentioned above have been checked and followed. The design report has incorporated the recommended mitigation measures.

During construction phase, there are no major environmental impacts in the enhancement project. However there are minor impacts like decrease in ground Water table and water logging, chemical contamination, air and noise pollution during construction, traffic disturbances and some disturbances in household water supply distribution. In order to minimize the impacts, specific arrangements have been made in the design and incorporated in the specification of work. The contractor is responsible to follow all the instruction given by the DSC and agreed specifications.

During operational phase also, there will be no significant impacts. However there may be minor impact on water right conflict (tap distribution) and occupational health and safety of workers. These issues will be addressed by and will be the responsibility of WUSC.

Consultation, Disclosure and Grievance Redress

Public consultations were done in the preparation of the project and IEE and throughout the project implementation period of the completed project.

During the preparation of this enhancement project and updated IEE, Public consultations were done at different phases. The first consultation was done during survey and design period. Further consultation was made with the stakeholders at project site after the project design report was approved.

The consultation was focused on environmental impacts, resettlement, social issues, relocation and compensation issues.

Monitoring and Reporting

The PMO, RPMO and DSMC will be responsible for environmental monitoring. The RPMO with support from the DSMC will submit monthly monitoring reports to the PMO. The PMO will consolidate the monthly reports and will send semi-annual monitoring reports to ADB. ADB will post the environmental monitoring reports on its website.

Conclusions and Recommendations

The proposed subproject is unlikely to cause significant adverse impacts. The potential impacts that are associated with design, construction and operation can be mitigated to standard levels without difficulty through proper engineering design and the incorporation or application of recommended mitigation measures and procedures. Based on the findings of the IEE, there are no significant impacts and the classification of the subproject as Category "B" is confirmed. No further special study or detailed environmental impact assessment (EIA) needs to be undertaken to comply with ADB SPS (2009).

1. INTRODUCTION

1.1 Background

1. The Enhance Functionality in Small Towns Water Supply and Sanitation Sector Project (STWSSSP) will support the government of Nepal (the Government) in improving water supply and sanitation facilities and services to 24 small towns in Nepal. Out of the 265 small towns in Nepal, Asian Development Bank (ADB) has already supported the Government, through successful implementation of earlier two projects in 50 towns. These include the 24 project for enhancement.

2. The Enhance Functionality in Small Towns Water Supply and Sanitation Sector Project (STWSSSP) will be implemented in 6-12 months period starting around first week of November, 2015 and will be funded by a loan using a sector lending approach of ADB. The Executing Agency is the Ministry of Water Supply and Sanitation and the implementing agency is the Department of Water Supply and Sewerage (DWSS).

3. The outcome will be inclusive and sustainable water supply and sanitation service delivery in selected small towns in Nepal. The project will implement improvements/rehabilitation works within the service area of already completed 24 projects. There will be minor civil works necessary for the enhancement of the components without changing the original technical and social concepts.

1.2 Objectives of IEE

4. The Updated IEE summarizes anticipated impacts and corresponding mitigation measures, monitoring and also includes cost and time frame for implementation.

1.3 Rational of IEE Requirement

5. The sub project IEE report was approved by government of Nepal in 2005. Now the sub project is envisaged to undergo for rehabilitation of project components such as, treatment plant (specific area) of transmission and distribution line. The proposed IEE is prepared as an integral part of bid document. However consultant has updated the contents of IEE report already approved from government of Nepal.

Methodology Used in Preparing IEE

- In the process of preparation of EMP, an extensive review of approved IEE and feasibility reports reviewed with some field based information
- Public consultations were held in the entire process of IEE study and during the disclosure of the draft IEE report to the local people. These processes have taken place and the results were documented. The involvement of the local people in EMP implementation activities have been recommended in EMP, 2000. Accordingly, in the process of EMP implementation, the following mechanism has been adopted to involve the local people in EMP activity:
 - Public Consultation and Involvement have been given highest priority in the implementation of Mitigation measures carried out by EMP; initially prior to the implementation, public consultation usually takes place and on the basis of decision of the consultation meeting, implementation of mitigation measures are being prioritized and carried out with the involvement of local people.
 - Monitoring is another component of EMP. Monitoring of Physical, Biological and Socio-economic components of Environment of the project is being carried out. In the process of compliance monitoring of the project construction, local people and construction workers are being involved and consulted

2. POLICY, LEGAL & ADMINISTRATIVE FRAMEWORK

2.1 ADB Policy

6. All projects funded by the ADB must comply with the Safeguard Policy Statement (SPS) 2009 to ensure that projects undertaken as part of programs funded under ADB loans are environmentally sound, are designed to operate in compliance with applicable regulatory requirements, and are not likely to cause significant environmental, health, or safety hazards. With respect to the environment, the SPS 2009 is underpinned by the ADB Operations Manual, Bank Policy (OM Section F1/OP, 2010). The policy promotes international good practice as reflected in internationally recognized standards such as the World Bank Group’s Environmental, Health and Safety Guidelines.¹

2.2 ADB Safeguards policy

7. ADB’s environmental safeguards policy principles are defined in SPS, 2009, Safeguard Requirements¹ and the IEE is intended to meet these requirements, Table 2-1.

Table 2-1: ADB SPS, 2009 Safeguard Requirements 1: Environment

SPS 2009 - Safeguard Requirements	Remarks
Use a screening process for each proposed project, as early as possible, to determine the appropriate extent and type of environmental assessment (EA) so that appropriate studies are undertaken commensurate with the significance of potential impacts and risks.	REA has been undertaken (Annex A), indicating that subproject is NOT: (i) environmentally critical; and (ii) adjacent to or within environmentally sensitive/critical area. The extent of adverse impacts is expected to be local, site-specific, confined within main and
SPS 2009 - Safeguard Requirements	Secondary influence areas. Significant adverse impacts during construction will be temporary and short-term, can be mitigated without difficulty. There is no adverse impact during operation. Hence, IEE is sufficient. The IEE including specific description of the environment and corridor of impact will be updated as necessary based on the final design and alignments.
Conduct EA to identify potential direct, indirect, cumulative, & induced impacts and risks to physical, biological, socioeconomic (including impacts on livelihood through environmental media, health and safety, vulnerable groups, and gender issues), and physical cultural resources in the context of the project’s area of influence. Assess potential transboundary global impacts, including climate change.	IEE has been undertaken to meet this requirement. (Section VI). No transboundary & global impacts, including climate change.
Examine alternatives to the project’s location, design, technology, and components and their potential environmental and social impacts and document the rationale for selecting the particular alternative proposed. Also consider the no project alternative.	Analysis of “with-subproject “or “without subproject” is presented in Section III.

¹New Version of the “World Bank Group Environmental, Health, and Safety Guidelines”, April 30 2007, Washington, USA. <http://www.ifc.org/ifcext/enviro.nsf/Content/EnvironmentalGuidelines>

SPS 2009 - Safeguard Requirements	Remarks
<p>Avoid, and where avoidance is not possible, minimize, mitigate, &/or offset adverse impacts and enhance positive impacts by means of environmental planning & management. Prepare an EMP that includes the proposed mitigation measures, environmental monitoring and reporting requirements, related institutional or organizational arrangements, capacity development and training measures, implementation schedule, cost estimates, and performance indicators.</p>	<p>An EMP has been prepared to address this requirement. Section IX</p>
<p>Carry out meaningful consultation with affected people & facilitate their informed participation. Ensure women's participation. Involve stakeholders, including affected people & concerned NGOs, early in the project preparation process & ensure that their views & concerns are made known to & understood by decision makers and taken into account. Continue consultations with stakeholders throughout project implementation as necessary to address issues related to EA. Establish a GRM to receive & facilitate resolution of affected people's concerns & grievances on project's environmental performance.</p>	<p>Key informant and random interviews have been conducted (Annex C). A grievance redress mechanism for the resolution of valid project-related social and environmental issues/concerns is presented in Section VIII.</p>
<p>Disclose a draft IEE (including the EMP) in a timely manner, before project appraisal, in an accessible place & in a form & language(s) understandable to affected people & other stakeholders. Disclose the final EA, & its updates if any, to affected people & other stakeholders.</p>	<p>The draft IEE will be disclosed on ADB's website prior to project appraisal. Copies of both SPS-compliant IEE and Government of Nepal-approved IEE will be made available at the offices of the PMO, Project Implementation Support Unit (PISU) and Water Users' and Sanitation Committee (WUSC) for public consultation. For the benefit of the community, the summary of the IEE will be translated in the local language and made available at (i) offices of executing and implementing agencies, (ii) area offices, (iii) consultant teams' offices; and (iv) contractor's campsites. It will be ensured that the hard copies of IEE are kept at places which are conveniently accessible to people, as a means to disclose the document and at the same time creating wider public awareness. An electronic version of the IEE will be placed in the official website of executing and implementing agencies and the ADB website after approval of the IEE by ADB</p>
<p>Implement the EMP and monitor its effectiveness. Document monitoring results, including the development and implementation of corrective actions, and disclose monitoring reports.</p>	<p>EMP implementation, reporting and disclosure of monitoring reports are in this IEE.</p>

SPS 2009 - Safeguard Requirements	Remarks
<p>Do not implement project activities in areas of critical habitats, unless (i) there are no measurable adverse impacts on the critical habitat that could impair its ability to function, (ii) there is no reduction in the population of any recognized endangered or critically endangered species, and (iii) any lesser impacts are mitigated. If a project is located within a legally protected area, implement additional programs to promote and enhance the conservation aims of the protected area. In an area of natural habitats, there must be no significant conversion or degradation, unless (i) alternatives are not available, (ii) the overall benefits from the project substantially outweigh the environmental costs, and (iii) any conversion or degradation is appropriately mitigated. Use a precautionary approach to the use, development, and management of renewable natural resources.</p>	<p>The subproject does not encroach into areas of critical habitats.</p>
<p>Apply pollution prevention and control technologies and practices consistent with international good practices as reflected in internationally recognized standards such as the World Bank Group's Environmental, Health and Safety Guidelines. Adopt cleaner production processes and good energy efficiency practices. Avoid pollution, or, when avoidance is not possible, minimize or control the intensity or load of pollutant emissions and discharges, including direct and indirect greenhouse gases emissions, waste generation, and release of hazardous materials from their production, transportation, handling, and storage. Avoid the use of hazardous materials subject to international bans or phase-outs. Purchase, use, and manage pesticides based on integrated pest management approaches and reduce reliance on synthetic chemical pesticides.</p>	<p>This requirement is only minimally applicable to the subproject in the aspect of waste generation, e.g., effluent from septic tanks and generated sludge and sludge disposal from water supply and sanitation structures. The subproject will not involve hazardous materials subject to international bans/phase outs.</p>
<p>Provide workers with safe and healthy working conditions and prevent accidents, injuries, and disease. Establish preventive and emergency preparedness and response measures to avoid, and where avoidance is not possible, to minimize, adverse impacts and risks to the health and safety of local communities</p>	<p>EMP provides measures to mitigate health and safety hazards during construction and operation.</p>
<p>Conserve physical cultural resources and avoid destroying or damaging them by using field-based surveys that employ qualified and experienced experts during environmental assessment. Provide for the use of "chance find" procedures that include a pre-approved management and conservation approach for materials that may be discovered during project implementation</p>	<p>The subproject will not affect any physical cultural resource. The EMP recommends the measure/s to mitigate adverse impact on physical cultural resources (PCRs) in case of chance find.</p>

2.3 Nepal's Environmental Policy and Legal Framework

8. The Interim Constitution of Nepal, 2007 defines the right to live in clean environment as one of the fundamental rights of its citizens (Article 16). It prescribes for the State to give priority to the protection of the environment and prevention of its further damage due to physical development activities (Clause 5 of Article 35). Proceeding from, and conformable to, the Constitution, the Government of Nepal has passed a series of environmental laws, policies and implementing regulations and standards. Among these, the basic legislation that provides the framework within which environmental assessment is carried out in Nepal is the:

- Environmental Protection Act (EPA), 1997. requires a proponent to undertake IEE or EIA of the proposed project and have the IEE or EIA report approved by the concerned sector agency or Ministry of Science, Technology and Environment (MoSTE), respectively, prior to implementation. The EPA: (i) sets out the review and approval process of IEE and EIA reports, that involve informing and consulting stakeholders; (ii) stipulates that no one is to create pollution that would cause significant adverse impacts on the environment or harm to public life and health, or to generate pollution beyond the prescribed standards; (iii) specifies for the Ministry in charge of environment (currently the MoSTE) to conduct inspection of approved projects to ensure that pollution prevention, control or mitigation is carried out according to the approved IEE or EIA report; (iv) provides for the protection of objects and places of national heritage and places with rare plants, wildlife and biological diversity; and (v) states that any person/party affected by pollution or adverse environmental impact caused by anybody may apply to the prescribed authority for compensation to be recovered from the polluter/pollution generator.
- Environmental Protection Rules (EPR), 1997, and its amendments in 1999 and 2007. Defines the implementing rule and regulations of the IEE/EIA process, elaborating the provisions in the EPA. The preparation, review and approval of IEE and EIA reports are dealt with in Rules 3 to 7 and 10 to 14. Schedules 1 and 2 list down the projects of activities that are required IEE and EIA, respectively, as amended in 2007.
- Other environmental and core labor policies, laws and rules that are relevant to the subproject are presented in Table 2-2.

Table 2-2: Other Relevant Environmental and Core Labor Policies, Laws and Guidelines of Nepal Applicable to the Subproject,

Policy/Law/Guideline	Year	Relevant Provisions	Remarks
Resources Act	1992	Comprehensive law on the development, use and conservation of water resources in Nepal, it aims to minimize damage to water bodies by requiring the conduct of IEE & preparation of IEE Report before granting license to use water resources for any purpose.	Government of Nepal environmental assessment report will be prepared based on this IEE.
		Proponents shall make sure that the beneficial use of water resources does not cause damage to other water uses/users (Article 4).	The source is groundwater to be drawn from the deep aquifer. Prevailing water source is the shallow aquifer and water drawn has Mn, Fe, Al and coliform levels exceeding National Drinking Water Quality Standard (NDWQS). Hence, people are eager to be connected to piped water supply system.
		Article 17 requires proponents to apply for any necessary land acquisition accordingly;	Site for the intake well, treatment unit, overhead tank is government land (Dept. of Forest).
		Article 18 requires the compliance to quality standards in making use of water resources. Article 19 prohibits the pollution of water resources. Under the Act are two regulations for drinking water purposes: (i) Water Resources Regulation, 1993, setting out the implementation procedures for the Act; and (ii) the Drinking Water Regulation, 1998, which specifies compliance with the drinking water quality standards and control of water pollution (or sanitation) as it affects drinking water.	Environmental Management Plan prescribes the compliance with NDWQS and its Directives during operation.
Labor Act	1992	Chapter 5 stipulates health and safety provisions at work places, keeping work premises clean and safe, e.g., (i) with provisions for solid waste, sewage and hazardous substance management; (ii) instituting measures to prevent dust, fumes and other impure materials that would adversely affect health; (iii) with supply of potable water and water for emergency situations; (iv) with arrangements for the use of protective devices and wears; (v) with fire safety arrangements; and (vi) measures for protection from hazardous machines/equipment and from physical injury or harm from lifting of heavy weights.	EMP provides measures to mitigate workers' health and safety hazards.

Policy/Law/Guideline	Year	Relevant Provisions	Remarks
Forest Act	1993	The Act prohibits the extraction of boulders, rocks, pebbles, sand or coil from national forests, defined as all forests, excluding private forests, whether marked or unmarked with forest boundary, to include waste or uncultivated lands, or unregistered lands surrounded by the forest or situated near adjacent forests as well as paths, streams rivers, lakes, riverine lands within the forest.	Subproject will not impact on any forest. EMP stipulates no illegal quarrying of natural aggregate materials.
National Environmental Policy and Action Plan (NEPAP)	1993	Of its five objectives, most relevant to the Project are to: (i) mitigate adverse environmental impacts; and (ii) safeguard national & cultural heritage & preserve biodiversity, within & outside protected areas.	Subproject will not impact on physical cultural heritage & biodiversity. EMP provides measures to mitigate impacts.
National Water Supply and Sanitation Policy	1998	The Policy requires the: (i) monitoring of water quality supplied by completed WSS projects; and (ii) evaluation of their benefits in improving health (e.g., reducing water-borne diseases) and in relieving the sufferings of women and other disadvantaged groups in carrying out their responsibilities over water collection and maintenance of sanitation and hygiene.	Monitoring of the quality of supplied water is prescribed in the EMP following the NDWQS Directives.
Drinking Water Rules	1998	The Rules: (i) gives the procedure for the settlement of dispute on use of water sources; (ii) requires water supplier to maintain the quality of water as prescribed in the Water Resources Act; (iii) prohibits water supplier to construct structures and conduct activities that would pollute the water source and cause significant adverse effect on the environment.	Monitoring of the quality of supplied water is prescribed in the EMP following the NDWQS Directives.
Local Self-Governance Act	1999	The Act gives Local Government the functions, duties & powers to: (i) conserve & protect their local environment & natural resources; (ii) plan, implement &/or operate & maintain local WS projects; (iii) implement or arrange for implementation local sanitation/sewerage & drainage projects; (iv) protect cultural heritage & religious sites; &/or (v) monitor project activities within their respective jurisdictions.	Provides basis for Local Government to monitor the environmental performance of the subprojects. EMP provides the responsibilities of Local Governments (LGs) in EMP implementation.
National Urban Policy	2007	Policy gives importance to environment conservation while carrying out urban development works and natural resource use; thus, supporting the required environmental conservation and protection in donor-assisted development projects.	Government of Nepal Government of Nepal environmental assessment report, based on this IEE, will be prepared to ensure environmental conservation and protection.

Policy/Law/Guideline	Year	Relevant Provisions	Remarks
National Urban Water Supply and Sanitation Sector Policy	2008	The Policy requires the IEE or EIA of proposed WSS projects in accordance with the EPA/EPR to: (i) incorporate consultations with key stakeholders, including end-point users; & (ii) specify measures to mitigate environmental impacts prior to, during construction & operation, as well as corrective measures.	Government of Nepal environmental assessment report will be prepared based on this IEE. This ADB IEE will be submitted to ADB for review and approval.
Implementation Directives for the National Drinking Water Quality Standards	2005	It sets out the water sampling, testing, analysis, monitoring and surveillance procedures to certify that the quality of supplied drinking water conforms to the National drinking Water Quality Standards.	Monitoring of the quality of supplied water is prescribed in the EMP following the NDWQS Directives.
Updated 15-Yr Development Plan for Small Towns Water Supply and Sanitation Sector	2009	The Plan defines the population threshold of “small towns” to be in the range of 5,000 to 40,000. Reference to Schedules 1 and 2 of the EPR, as amended in 2007, places water supply projects in small towns under Schedule 1 or within the threshold of water supply projects requiring only an IEE. The Plan emphasizes monitoring and evaluation as an important component of a project to determine the overall impact of a project.	EMP prescribes environmental effects and performance monitoring.
Solid Waste Management Act	2011	Article 4 provides that the management of hazardous, medical, chemical or industrial waste rests upon the generators of such wastes. Management should be as prescribed in the Act. Article 5 provides that individuals and entities have the duty to reduce the amount of solid waste generated while carrying out work or business.	EMP prescribes eco- friendly management of solid and hazardous wastes.

9. The key Government of Nepal environmental quality standards are: (i) National Ambient Air Quality Standards for Nepal, 2003; (ii) National Noise Standard Guidelines, 2012; and (iii) National Drinking Water Quality Standards, 2006, which would also be applied to surface and ground water quality monitoring since these resources are used for drinking.

10. Nepal is party to the following international environmental agreements that have broad relevance to works and environmental assessment of works under the project: (i) World Heritage Convention, in 1978; (ii) Convention on Wetlands of International Importance Especially as Waterfowl Habitat (Ramsar Convention), in 1987; (iii) Convention on Biodiversity, in 1992, (iv) Vienna Convention for the Protection of the Ozone Layer and its Montreal Protocol and subsequent London Amendment, in 1994, and (v) Basel Convention on the Control of Transboundary Movements of Hazardous Wastes and Their Disposal, in 1996.

11. The relevance of the aforementioned environmental agreements to the subproject are on their emphasis for human activities (such as development projects) to: (i) take on/institute measures to protect the local, as well as global, natural resources and/or environment; (ii) prevent and/or reduce the causes of climate change; and (iii) anticipate and mitigate the adverse impacts of climate change. The country is also committed to the Millennium Development Goals (MDG), the seventh goal of which is to “ensure environmental sustainability” targeting the reverse of loss of forest and environmental resources, reduction of biodiversity loss, and increase in the proportion of population with sustainable access to safe drinking water and basic sanitation.

3. ANALYSIS OF ALTERNATIVES

3.1 Alternatives considered in the approved IEE report 2006

12. A number of alternatives are identified and analyzed for the proposed water supply and sanitation project. Alternatives regarding the sources, available technologies, sitings of different system components, service levels, period of construction etc. are taken into consideration. Analysis for no action scenario has also been dealt to signal out the importance of the proposed project. The alternative listed below provides a basis for taking decision on whether: The proposal should move forward for implementation to the project stakeholders.

13. A number of alternatives are identified and analyzed for the proposed water supply and sanitation project. Alternatives regarding the sources, available technologies, sitings of different system components, service levels, period of construction etc. are taken into consideration. Analysis for no action scenario has also been dealt to signal out the importance of the proposed project. The alternatives listed below provide a basis for taking decision on whether the proposal should move forward for implementation to the project stakeholders.

3.1.1 No Action

14. It denotes that the proposed water supply and sanitation project will not be considered for implementation and the ever-increasing demand on water will be managed by the existing system. In this scenario the water supply service levels will degrade over the existing situation in years to come. Likewise, sanitation situation in the service area will not improve and be a source of water pollution and the place will converted to more unhygienic place for living than of today.

15. Owing to the situation, the local people are in favor of implementing water supply and sanitation project by contributing some amount of their capital in project construction with full operation and maintenance responsibilities.

3.1.2 Alternative Sources of Water Supply

16. During the feasibility study stage, assessment of the existing water supply system and prospects for water augmentation through its improvement were looked upon before exploring other possible and cost effective feasible sources. Different alternative sources were identified and studied. From the feasibility study level with environmental appraisal and screening of all the identified sources, it is found that the present combination of Katuwa Khola source and groundwater boring source has been found to be the best alternative amongst the alternatives identified. The selected alternative was found to be the best in terms of the size of investment, operation and maintenance, level of tariff, water quantity and quality, reliability, continuity, source status and social and environmental grounds. Hence, the detailed engineering survey, design and other studies, including environmental studies required for investment have been carried out in concurrence with the community representatives and project personnel.

3.1.3 Choice of Technology

17. Alternatives from gravity-fed to pumping type water supply systems were identified. Based on the past experience, initial investment required and operation and maintenance costs to be incurred, depreciation of equipment and machines, skills required for O&M, choice of the WUSC etc. present combination of water supply system be recommended for implementation. An appropriate and locally available and labor based technology with minimum or no use of equipment and machineries, for construction of the project will be adopted. Actually, the gravity-fed water supply system was chosen based on technical and economical grounds rather than solely on environmental aspects.

3.1.4 Water Supply Service Levels

18. Alternatives based on different water service levels range from the intermittent to continuous supply, treated water, per capita daily water supply, house connection facilities to yard and community taps, metered and un-metered supply system, progressive to flat tariff rates etc. Analysis on these aspects were carried out and discussed with the consumers before finalizing the mode of water supply service levels. Finally, the water supply service levels was fixed to provide treated water ensuring per capita daily volume of water on progressive tariff rate basis preferably with house connection facilities.

3.1.5 Sanitation

19. Options on water-borne sewerage system, on-site sanitation system and private latrine with septic tank and soak away pit system were looked upon and were analyzed in terms of applicability, affordability, requirements, desired level of services by the communities, level of pollutions and associated impacts on health and hygiene. Considering all factors, latrines on individual households with limited storm water drainage facilities in densely populated areas are taken into consideration for implementation.

20. In order to minimize the effects of haphazard solid waste dumping practices, local people through WUSC will be trained for safe disposal techniques of waste encouraging them for reuse and composting of wastes.

3.1.6 Period of Construction

21. Longer period of time allocated for construction than required will increase the cost of construction. Based on the type of project, two years of construction period has been recommended in consultation with the stakeholders associated with the proposed project.

3.1.7 Choice of Alternative

22. Based on alternative analysis, combination of Katuwa Khola source and groundwater boring source is found to be the best amongst others considered for the study. The implementation modalities, which proposes for a two years of construction period with the assurance of supplying potable water based on daily per capita water demand combined with sanitation facilities is recommended amongst the alternative proposed.

3.2 Alternatives for the Updated IEE

23. The water supply system for the town of Ghorahi was constructed several years before under STWSSP 1, funded by ADB. The project is in operation at present. The WUSC is the operating agency. The project had anticipated a 24 hour service and water quality standards within the NDWQS. After a few years of operation, it was observed that this anticipation was not fulfilled due to some problems. The problems were observed both in technical as well as social and institutional field. Therefore some enhancement measures were necessary. This project is designed to cater for such enhancement works.

24. IEE had been carried out in accordance with the prevailing rules and regulations of ADB and the GoN incorporating the alternatives like “without –sub project or do nothing” and “with sub-project” was carried out in 2006.

25. As such, alternatives for the water supply project have not been studied in the design report.

4. DESCRIPTION OF SUBPROJECT

4.1 The Study Area

26. Ghorahi Small Town Water Supply and Sanitation project is located in Dang district of the Mid-Western Development Region of Nepal. The service area of the project lies in Ghorahi municipality. Geographically it is located at 28° N Latitude and 82° E Longitude. The municipality is bordered by Laxmipur VDC (separated by Sisne Khola) in the east, Narayanpur and Hapur VDCs (separated by Gujre Khola) in the west, Shaigha and Siuja VDCs in the north and Saudiyar VDC (demarcated by Damodar road) in the south.

27. The climate of the project area is sub-tropical. The average maximum temperature during summer fluctuates between 29° C & 33° C and minimum temperature in winter season ranges range from 10° C to 18° C. The relative humidity is in the range of 84% to 87 %. The average annual rainfall is estimated at approximately 1500mm per year.

28. The project was implemented to serve ward nos. 6 & 10 and part of 2, 3, 4 & 11 of Ghorahi municipality. According to Financial Appraisal Report, the project was designed to serve a total population of 31,230 in base year 2006 and 56,231 in the design year 2020. Ghorahi is fast growing town and the economy of the service area is predominately commercial and service based.

29. The core service area is the market area and mostly located in Ward nos. 10 and 11. Other parts of the service area are mostly semi-urban type. The settlement pattern in core service area (Bazaar area) is dense, whereas in other adjoining parts of the service area the settlement pattern ranges from moderately dense to scattered.

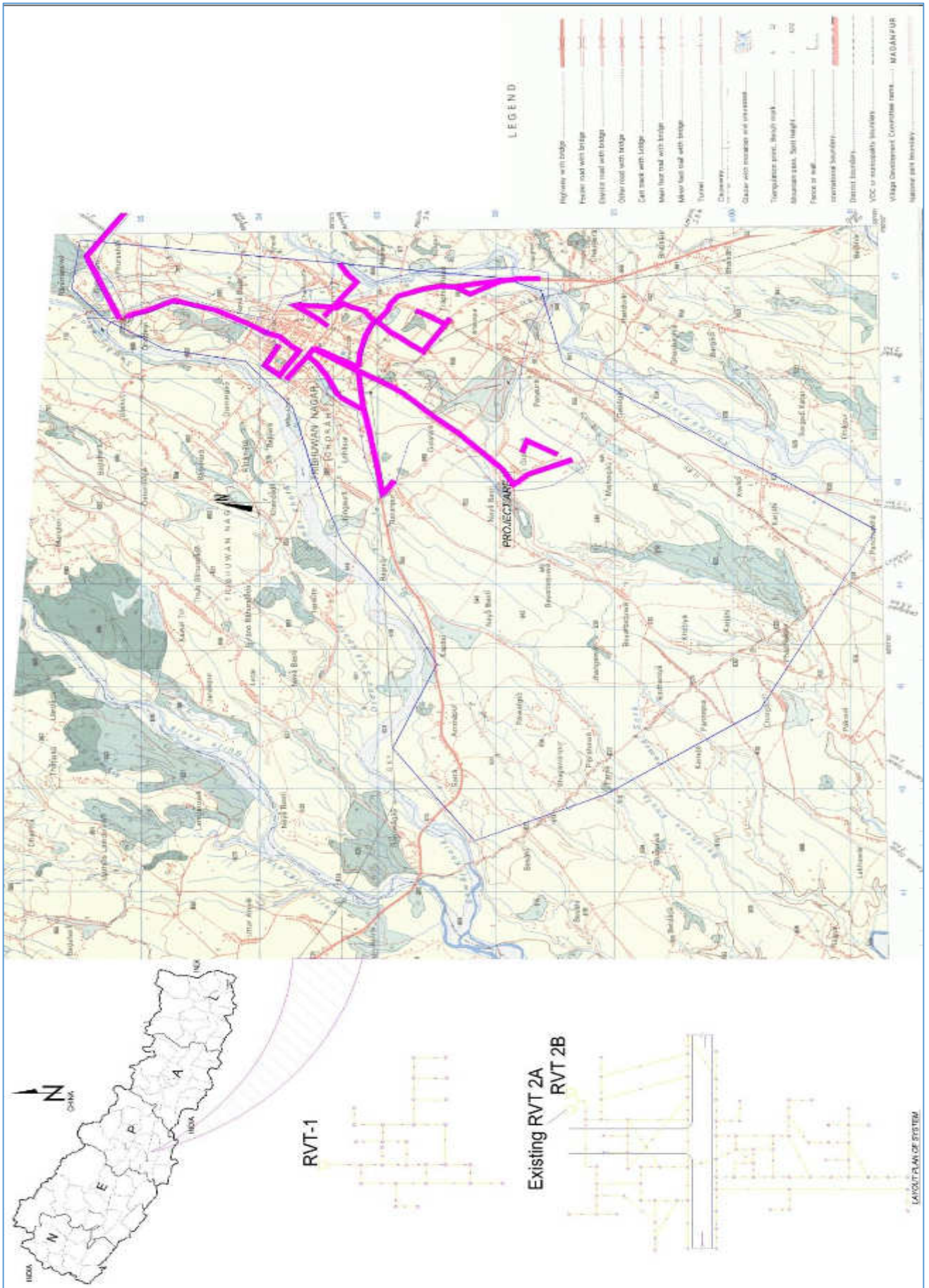

Figure 4-1: Location of the Subproject Area

4.2 Existing Condition and Need for the Subproject

30. The sub-project includes the following works;

- i. Construction of 575 m³ ground reservoir
- ii. Three 25 lps treatment plant
- iii. 10.0 km of pipe line laying
- iv. Construction of Chlorination unit

The technical details are shown in Table 4-1.

4.2.1 General Information

1. **Name of the project** : Enhance Functionality in Small Town Water Supply and Sanitation Sector Project
2. **Name of sub project** : Ghorahi Small Town Water Supply & Sanitation Project, Dang
3. **Service area of the project** : Ward 6 & 10 and part of 2, 3, 4 & 11 of Trivubannagar Ghorahi Municipality.
4. **Total Project Cost** : NRs 68,093,619

4.2.2 Technical Information Component

31. Details of technical information are mentioned in

I. Water Supply Component : NRs 68,093,619

Table 4-1: Technical details

S. No.	Name of structure	Existing	Additional	Total
1	No. and capacity of Reservoirs:	7(1,710 cum)	3(575 cum)	10(2,285cum)
2	Treatment Facilities	3(25 lps PST, HRF,SSF), and 40 lps PF) Chlorination Unit	Chlorination Unit (Rehabilitation)	3(25 lps PST, HRF,SSF), and 40 lps PF) Chlorination Unit
3	Pipeline Length:			
3.1	Transmission	11.4 km	0.3 km	11.7 Km
3.2	Distribution	68 km	9.7 km	77.7 Km
3.3	Total	79.4 Km	10.0 Km	89.4 Kms
4	Guard House	2	None	2
5	Generator / Operator House	2	None	2
6	Chlorination Unit with lab	None	2	2
7	Office Building:	One	None	One
8	Surface Intake/Borehole Drilling:	Surface Intake 3 TW 8	TW 3	Surface Intake 3 TW 11
9	Fire hydrant	Three	None	Three

S. No.	Description	Existing (2014)	Design year (2022)	Design year (2030)
10	Household connection	8,945	12,151	16,501
10.1	Fully plumbed	5,188	8,992	14,851
10.2	Yard connection	3,757	3,159	1,650
10.3	Community	26	30	37
10.4	Institutional	35	44	53
10.5	Total	9,006	12,225	16,591
11	Total Water Demand			
11.1	MLD	4.86	7.04	10.15
11.2	LPS	56.3	81.48	117.47

4.2.3 Socio- Economic Information

Total Household Number and Population (Pop.)

a) Present year (2014): 8,945/45,620

b) Design year (2022): 12,151/61,955

c) Design year(2030): 16,501/84,140

4.2.4 Financial Information

32. The financial planning for the enhancement project is as follows;

- i. Total investment 100%
- ii. Government: Grant 70%
- iii. WUSC Contribution: 5 – 10% of total investment as cash (% to be decided later)
- iv. TDF Loan: 20 – 25% of total investment to be provided to the WUSC (% to be decided later)

2. Weighted Average Tariff NRs 18 per cum

3. Cost Per Capita and per household

Description	Base year 2014	Design Year 2022	Design Year 2030
Cost per Capita	1,492.63	1,099.08	809.29
Cost per House hold connection	7,612.48	5,603.95	4,126.64

4.3 Sub Project Construction Schedule

33. It is expected that the contract will be awarded by the last week of November 2015 and the construction work will be completed by the last week of November 2016. The detail of work is shown in Figure 4-2.

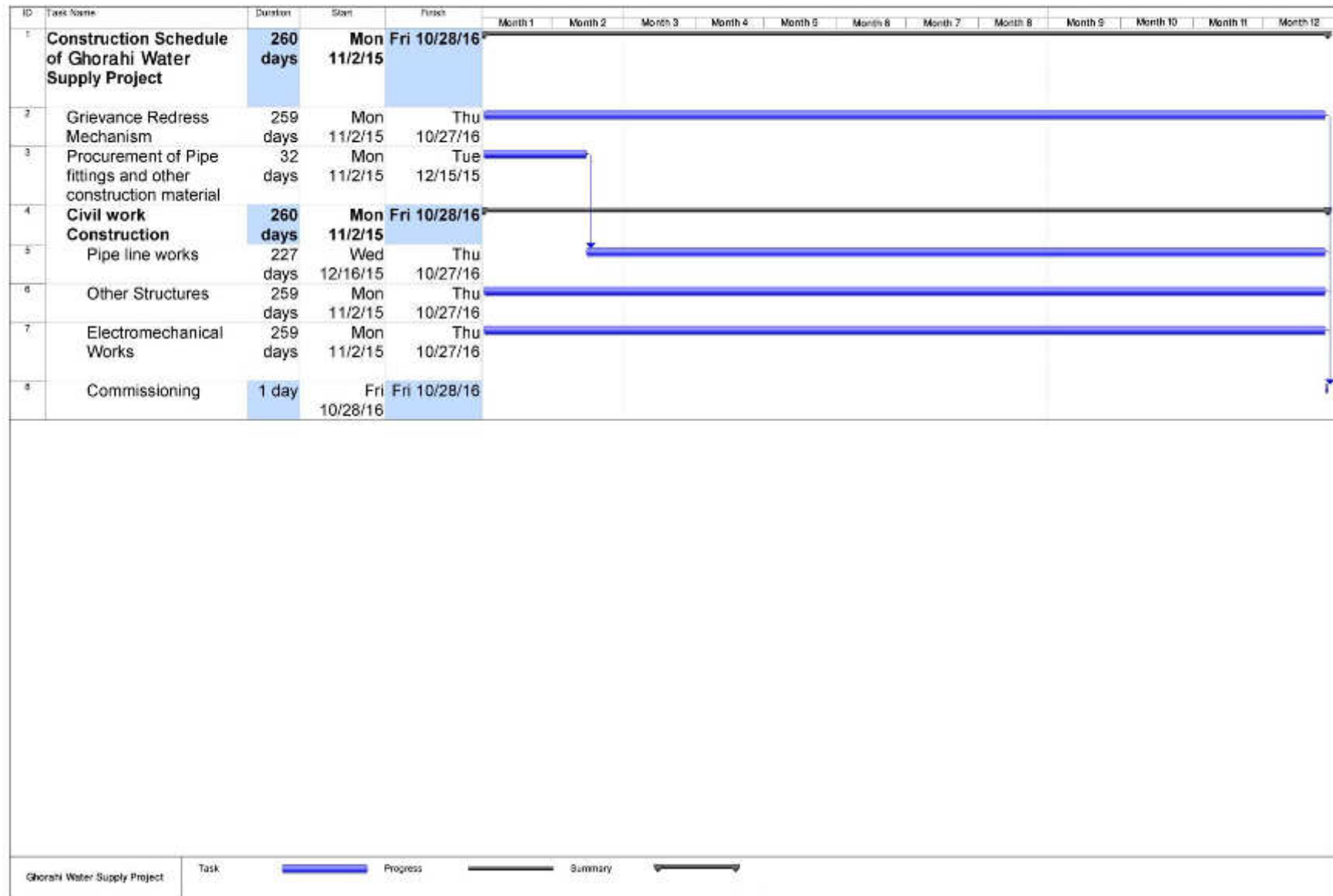

Figure 4-2: Construction Schedule

5. DESCRIPTION OF THE ENVIRONMENT

5.1 Physical Profile

5.1.1 Topography

34. Tribhuvan Nagar, Ghorahi, situated at 28° N Latitude and 85° E Longitude, with elevation 725 metres above mean sea level, is the district headquarters of the Dang district. The project area is located along Lamahi – Tulsipur black topped highway at Dang. Geomorphologically, Tribhuvan Nagar (Ghorahi) Bazaar area is situated in flat inner Dang valley and is made up of thick gravelly deposit. The Surrounding Mountains are rocky and is made up of calcite and quartzite Group. Major Hazards at the basin is flood, whereas in the mountain slope land slide and various mass wasting processes are dominants.

5.1.2 Geology and Soils

35. Alluvial/loam, soft soil and calcareous beds together with colluvial deposit and thin soil layer mixed with gravel are predominant in this area. Acidic soil is usually found in the forest area. There are four orders of soil available in this district namely entisols, inceptisols, mollisols, and alfisols. The areas around the sources and the proposed reservoir site are stable without any apparent landslides.

5.1.3 Climate

36. The climate of the project area is sub-tropical. Based on record of Year 2000, the temperature at the project valley varied from 15.6°C to 28.6°C with total annual rainfall being 1969 mm (ISRSC, 20004).

5.1.4 Surface and Groundwater

37. The Ghorahi Water Supply Sub-project uses Surface water source and Ground Water source.

S.No	Name of Source	Design discharge (lps)	Maximum Discharge(lps)	Minimum discharge (lps)	Remarks
1	KatuwaKhola (Scheme # 1)	23.6	4	3	In scheme no. 4 one TW is not in operation.
2	KatuwaKhola (Scheme # 2)		4	3	
3	KatuwaKhola (Scheme # 3)		20	15	
4	System 4				
4.a	TW1(KatuwaKholaTol)	2 TW 20*2=40 lps	11	11	
4.b	TW2(KatuwaKholaTol)		11	11	
4.c	TW3(Chamaisota)		Not in operation		
5	System 5				
5.a	TW1(JanakiTole		5	5	
5.b	TW2(Nawjyotitole)		5	5	
5.c	TW3(Buddhi Garage)		5	5	
5.d	TW4(RantapurTole)		7	6	

S.No	Name of Source	Design discharge (lps)	Maximum Discharge(lps)	Minimum discharge (lps)	Remarks
5.e	TW5(ShryeKhola)		5	5	
5.f	TW6(GuleriaTole		4	4	
5.g	TW2(Office Compound)		4	4	
	Total	73.6	85	77	

38. There are mainly 5 schemes of sources in TribhuwanNagar(Ghorahi) water supply system. 1,2 and 3 scheme is mainly comprise of stream source from KatuwaKhola with design discharge 23.6 lpswhile scheme 4 and 5 comprise of TWs of 11 numbers in total having design discharge ranges from 5-10 lps. Out of 4 TWs one TW is failed and which needs repairing.

5.1.5 Flora

39. It can be expected that three types of forests would be the natural habitat of the area, namely Shorea robusta (sal); Acacia catechu (khayar)-Dalbergia sissoo (sisau), other riverine forests and grasslands.

40. The Shorea robusta forest is dominated by the Shorea robusta species with common associates of Terminalia tomentosa (Asna), Adina cordifolia (karma), Anogeissus latifolia (bud dhayera), Lagerstroemia parvifolia (botdhaiyero), Dillenia pentagyna (Tantari), Syzygium cumini (jamun) and Semecarpus anacardium (bhalayo), etc.

41. The acacia catechu-dalbergia sissoo forest is found on newly deposited alluvium, often gravelly along streams and rivers.

42. The other riverine forest consists of tropical evergreen forest dominated by syzygium cumini (black plum) tropical deciduous forest usually dominated by Bombax ceiba (simal), Holoptelia integrifolia (chepte pagro) and Trewia nudiflora (pindar) species.

43. Medicinal plants of significance that would be expected here are Sikakai (Acacia concinna), Assuro (Adhetoda vasica), Tulasi (Ocimum sanctum), Kureelo (Asparagus racemosus), Harro (Terminalia cheberia), Barro (Terminalia felerica) and Amala (Embllica officinalis), etc.

5.1.6 Fauna

44. No natural forest to be habitat for wild animals exists in the service area. However, the Charali forest was known to have deer and many other wild animals. It does not have any of the wild animals at present.

45. It is possible that snakes like King Cobra (Ophiophagus hannah), Green Pit Viper (Trimeresurus albolabris), Common Krait (Bungarus caeruleus) and the Indian Python (Python molurus) would be present in the fields.

5.1.7 Protected Areas

46. Protected areas are almost nonexistent. A small patch of forest (1700 hectare) about 5 km to the east from Ghorahie known as Char Ali Nicha Jhoda and a tiny patch of sal frees (1 hectare), which is known as Salghati in Charpane 3 and a pond Birat which as per the mythology was built by King Birat during the Mahabharat period. It has an area of 3.5 hectare.

5.1.8 Water Quality Analysis

47. In the enhancement project additional units of SSF and Chlorination are proposed. The detail analysis of the water quality report is presented in Annex 2 of this report.

48. Water quality analysis were done for all critical sub project components such as intake, water before and after treatment plant. Samplings were also done in the distribution networks as well as randomly selected HHs taps to assure the quality. Mainly Physical component testing was done as pH, Turbidity, Electrical conductivity temperature. Similarly the various chemical components were also tested mostly like Calcium, Iron, Magnesium, Arsenic, Ammonia, Chromium, Nitrate, Sulphate, Chloride, Fluoride and Total Hardness as well.

49. In biological mainly parameter like Total Coliform and Fecal Coliform were tested for. If any contamination is encountered simultaneously the chlorination unit, pressure filter unit, slow sand filter treatment units should be provided. In case of this Water supply sub project due to the presence of Coliform, SSF and Chlorination units are constructed and now functioning.

5.2 Socio Economic Condition

5.2.1 Population, Communities and Occupation

50. According to the survey report conducted by ENPHO, the total population of proposed area of Tribhuvan Nagar municipality is 27525. Out of this, the family member is 16134 and other than family member is 11391.

51. The households having family size upto 1 to 2 and 3 to 4 are 25 and 25.3% respectively, whereas households having 5 to 6 family members is 31.1. The average family size has been estimated 7.49.

52. Majority of the people that is, 29.36% are engaged in agriculture. The second occupation is business, 23.16%; whereas service comes under third rank. 11.9% is found to be economically dependent.

53. Based on field survey, households having income less than Rs. 1,835 per month are classified as below the poverty level and this level of household comprises 7.8% of total. More than 46% of the total households earn between Rs. 3000 to Rs. 7,500 per month. 13.58 percent of the households earn between Rs. 7,500 to Rs. 10,000 per month. 22.2 percent of the households earn above Rs. 10,000 per month. Median income is above Rs. 4,500 per month.

5.2.2 Health and Sanitation

54. There is a District Hospital in the Municipality, a private clinic, a vaccination clinic, and number of women Health volunteers and trained midwife. Besides a Mary Stopes Centre and Nepal Family Planning Association Clinic are providing service. There is a good water supply system in the main bazaar area. Of the 3260 households 1181 have connection from the town supply. 1939 HH have only tubewell for drinking water. 140 have dug wells. Even those HH, which have connection to the town supply, have tube well.

55. The sanitary condition of project area is more or less good in ward no. 10 and 11. Majority of the households have toilets. Out of 3144 households surveyed, 2087 do have toilets that are 66.4%. Toilets of pit latrines pour flush, and cistern flush type are being used.

5.2.3 Economic Characteristics

Industries

56. Although not adequate to give full employment to the total population, the project area is economically the most active location in the region. There are a number of industries in the area. Most of them are agro based. The number of service industries is quite substantial.

Agricultural Development

57. The land is fertile for agriculture and the rate of production is good. The main crops are paddy and maize. Two crops of paddy or one each of paddy and maize are planted in a year. Besides wheat, oilseeds, pulses are grown here. Cultivation of vegetables including off seasonal is conducted commercially.

Mineral Development

58. Mineral exploitation activities are nonexistent.

5.2.4 Infrastructure Facilities

59. All major infrastructural facilities like water supply, roads, electricity and telephones/communication are available to the consumers in the service area.

60. Tribhuvan Nagar (Ghorahi) town being the district headquarters of Dang district, most of the government district level offices, banks, telecommunication and electricity offices are located in the project service area.

Transportation

61. The project service area has blacktopped road linkage reliable transportation facility having linkages with national and strategic road network in the kingdom of Nepal.

5.2.5 Land Use Planning

62. There will be temporarily loss of agricultural production during construction phase of the project. The system components are not within the agricultural land and hence will have no effect on agricultural and agricultural production.

5.2.6 Quality of Life Values

63. Quality of life values related to socio-economic, health and hygiene, occupation and employment and cultural aspects will be enhanced by the implementation of the project. The proposed project being small in size and simple in nature will impart positive environmental impacts on socio-economic values of the local people.

64. Potential environmental impacts have been screened for Tribhuvan Nagar (Ghorahi) Water Supply and Sanitation Project. Being a water supply and sanitation project it would have minimal environmental impacts, the obvious one being pollution of groundwater due to nitrates and bacteria. An appropriate latrine design would be adopted and necessary advice provided to the users regarding the same. Another problem likely to be observed in the project area similar to plain Terai settings is the wastewater logging near the community tap stands. Any additional community taps will be located in relatively higher spots to make them free of water logging. Poor or non-existent road side drainage in most of the sections of bazaar area will also cause water logging problem. For this, storm water drainage will be constructed by the project in core town area. Although not covered completely, the provision of road side drain generates environmental awareness on the part of local beneficiaries and local institutions.

5.3 Resettlement, Relocation and Compensation Issue

65. The various project components do not require resettlement of households or relocation. The system network has followed public property line and hence the issue of resettlement or relocation is not evident. The minutes of stakeholder consultation meeting also suggests that there is no need of resettlement or relocation.

66. The land required for construction of treatment plant and reservoir has been purchased by the WUSC and there is no need to provide compensation from the project side..

6. DESCRIPTION OF IMPACT ASSESSMENT

67. No significant impacts of project construction and operation were anticipated (IEE, 2005), but the following impacts were likely to occur. The project is now in operational phase and that all the physical and biological and socio-economic cultural impacts have been mitigated. In the enhancement project as well the same type of impacts are likely to occur.

6.1 Physical Environment

68. Physical Impact covers impacts on physical resources such as air, water, soil, rocks etc. The positions of a water table keep on fluctuating up and down in relation to wet and dry weather. Porous sand and gravel aquifers yield more water than silt or clay deposits. Hence physical testing of soil structure will help understanding the water availability.

6.1.1 Impact on Land Use Pattern

69. Intake structure, reservoir and treatment plant would require some land area in addition to permanent site to facilitate construction activities, which is envisaged to alter the land use during construction period. The implications of such land use may effect on soil, productivity and land use pattern.

6.1.2 Flooding and Stagnant Water Problem

70. During monsoon season the project area will be affected from flooding and may create the condition of stagnant water. Absence of drainage system in the project area will create flooding problems. This might create public health problem due to increase in number of vector species like mosquito, snails and others.

6.1.3 Impact on Water/Land Quality

71. Excavation and construction spoils are the major outcomes of construction activity. Besides, the workforce camps and their sanitary behavior might produce unwanted waste materials. The spoils and waste materials may have adverse implications on adjoining water sources.

6.1.4 Impacts of sediments and Disinfecting Chemicals

72. Issues like release of sediments from treatment plants, and the use of disinfecting chemicals might affect the water quality. Such effects are minor in nature and can be easily mitigated during the operational phase.

6.1.5 Water Volume/Quality

73. Over extraction water may decrease the volume of water and improper treatment of water also decrease the quality of water which may arise issues affecting the ground water sources of water.

6.2 Biological Environment

6.2.1 Impact on Natural Vegetation and Ecology

74. The natural vegetation and ecology of the project area may be disturbed due to construction activities of the different project components. Besides, the activities of workforce on the adjoining forest may affect the habitat of wildlife.

6.2.2 Impact on Aquatic Life

75. The source being ground water no impact on aquatic life is envisaged due to implementation of the project

6.2.3 Loss of Habitat

76. Clearance of vegetation along the bulk distribution pipeline, and trunk transmission pipeline, may result loss of some forested habitat of wild life and consequently affect the endangered species.

6.2.4 Impacts on Air Quality

77. Dust will be generated from inadequately managed or haphazard: (i) earthworks such as clearing, grubbing, excavations and drilling; (ii) demolition works; (iii) stockpiling of natural

aggregates, excavated materials and spoils; (iii) transport, loading and unloading of natural aggregates; (iv) movement of construction-associated vehicles; and (v) on-site rock crushing, cement mixing/concrete batching, borrowing. The significance of dust impact will be high in the bazaar area where more population reside and work and where urban socio-economic activities concentrate. Increase in concentration of vehicle- and process related pollutants will arise from the movement and operation of construction vehicles, equipment and hot-mix plants.

6.2.5 Impacts on Acoustic Environment

78. Noise and vibration emitting construction activities include earthworks, rock crushing, concrete mixing, movement and operation of construction vehicles and equipment, and loading and unloading of coarse aggregates. The significance of noise and vibration impacts will be high in areas where noise-sensitive institutions such as health care and educational facilities are situated. These impacts will be temporary and short term.

6.2.6 Impacts on Traffic and Temporary disturbance

79. During construction phase, implementation of distribution network pipeline will create disturbance to local transport system. The significant impact will be seen in market and busy area only. These impacts will be temporary and short term.

6.3 Socio-Economic and Cultural Environment

80. Many of the adverse impacts on socio-economic and cultural aspects will be limited to construction stage. The following socio-economic issues have been considered in IEE.

6.3.1 Land Acquisition

81. The land required for the construction of permanent facilities has been managed by WUSC and no disputes are observed. Similarly there is no necessity of relocation or resettlement.

6.3.2 Outside Workforce Conflict/Health/Pollution/Culture

82. Involvement of outside workforce in the local area may initiate conflict between the locals and outsiders due to cultural reasons. Disease transmission, pollution and competition for the available resources with outsiders might arise.

6.3.3 Workers' Health and Safety Hazards

83. Like communities, workers will also be exposed to the cross-cutting threats of the aforementioned impacts during construction. Inadequate supply of safe/potable water and inadequate sanitation facilities; poor sanitation practices on site; poor housing conditions; the handling and operation of construction equipment; handling of hazardous substances; exposure to extreme weather and nonobservance of health and safety measures, pose additional threats to the health and safety of construction workers. Construction workers may also be potentially exposed to communicable and transmittable diseases in the community and in the workforce.

6.3.4 Water Right Conflict

84. Involvement of outside workforce in the local area may initiate conflict between the locals and outsiders due to cultural reasons. Disease transmission, pollution and competition for the available resources with outsiders might arise.

6.4 Beneficial impacts

85. However there are some benefits of the project implementation; particularly on the following:

- Increase in agricultural and livestock products
- Employment generation
- Maintaining the health and sanitation activities
- Increase in quality of life values
- Change in cropping pattern

7. DESCRIPTION OF MITIGATION MEASURES

7.1 Physical Environment

7.1.1 Impact on Land Use Pattern

86. The STWSSSP is located in Tribhubannagar Ghorahi Municipality in the private land of about 2 Ropanis owned by the WUSC and with boundary wall constructed. It owns land for other structures like Intake,RVT, WTP and others (both existing and to be constructed in the enhancement project). It was ensured in design, that the intake and other water retaining structures like, Intake,RVT, WTP and others are well protected with good drainage to be located on stable ground. Therefore, the project implementation would have less or no effect on soil, productivity and on the land use pattern.

7.1.2 Flooding and Stagnant Water Problem

87. Proper management of drainage system needs to be improved. Contractor should be instructed not to store construction materials along the water ways.

7.1.3 Water/land quality

88. The project uses sub surface water that will be taken from below the water bed of the river by using infiltration gulley technique. Therefore the quality of water is expected to be clean. However the pollution in the surface water may have negative effect. The intake point is upstream from the settlement area and hence external pollution is also not foreseen. Thereforethereis ground water pumping, there is less or minimum effect on water quality. Proper drainage system should be made to avoid water logging and the quality of water sources should be protected. Urination, defecation and dumping of solid and liquid waste in open areas, and water ways may be the potential cause of the pollution of surface and sub-surface water and such activities should be strictly prohibited.

7.1.4 Impacts of Sediments and Disinfecting Chemicals

89. The water quality should be maintained within WHO/NSWQS standards. Filtration and chlorination should be provided to bring the water quality to acceptable levels. Similarly, a manual on water testing and chlorine dosing should be prepared and provided to WUSC.

7.1.5 Water Volume

90. The water should be equally distributed to all the users in a controlled way. The amount of water that required should only be extracted.

7.1.6 Impacts on Air Quality

91. Some mitigation measures include: (i) confining earthworks according to a staking plan and excavation segmentation plan that should be part of the working documents and/or C-EMP; (ii) watering of dry exposed surfaces and stockpiles of aggregates at least twice daily, as necessary; (iii) if re-surfacing of disturbed roads cannot be done immediately, spreading of crushed gravel over backfilled surfaces; (iv) during demolition, watering of exterior surfaces, unpaved ground in the immediate vicinity and demolition debris; (v) hoarding active work sites in populated areas; (vi) requiring trucks delivering aggregates and cement to have tarpaulin cover and maintain a minimum of 2' freeboard; (vii) limiting speed of construction vehicles in access roads and work sites to maximum of 30 kph; and (viii) providing pollution controls in batching and hot-mix plants.

7.1.7 Impacts on Acoustic Environment

92. Some mitigation measures include: (i) using equipment that emit least noise, well maintained and with efficient mufflers/exhaust silencers; (ii) restricting noisy activities to daytime and overtime work to avoid using noisy equipment; (iii) limit engine idling to a maximum of 5 minutes; (iv) spread out schedule of material, spoil and waste transport (v) minimizing drop heights when loading and unloading coarse aggregates; and (vi)Identify any buildings at risk from vibration damage and avoiding any use of pneumatic drills or heavy vehicles in the vicinity. Complete work in these areas quickly.

7.1.8 Traffic and Temporary disturbance

93. Some mitigation measures include: (i) distribution pipeline work will be done during night time, (ii) diversion need to be made if work is of long duration.

7.2 Biological Environment

7.2.1 Impact on Natural Vegetation And Habitat

94. The loss of vegetation from construction activities of contractors and construction workforce is recommended to be minimized through the enforcement of the following provisions.

- Prohibition on illegal felling of trees and encroachment of the community forest should be made mandatory.
- Progressive rehabilitation and afforestation of the areas not acquired by the project structures after the completion of the construction activities should be carried out. Such afforestation program is recommended to plant saplings of trees, shrubs and herbs by establishing a nursery or pre-arrangements of such saplings from the local or district level nurseries.
- To enhance the conservation of endangered, protected and threatened species, it is recommended to plant the saplings 2 times the number of felled trees.

7.3 Socio-economic and Cultural Environment

7.3.1 Land Acquisition

95. The land required for the construction of permanent facilities has been managed by WUSC and no disputes are observed. Similarly there is no necessity of relocation or resettlement. Vegetation and agricultural products should be compensated through the afforestation and agricultural enhancement programs in the STWSSSP area.

7.3.2 Outside Workforce Conflict/Health/Pollution/Culture

96. Outside workers should be provided with the facilities of camps and should be instructed to not to; i) indulge with local people ii) involve themselves for hunting of wildlife iii) involve themselves in social disharmony activities.

7.3.3 Workers' Health and Safety Hazards

97. Some of the mitigation measures for community health and safety hazards: (i) strictly enforce on workers the use of protective wears; (ii) provide safe access to and from work sites; (iii) provide adequate housing at the workers' camp with adequate basic services and provide adequate water supply and sanitation facilities at work sites; (iv) arrange with nearest health center and hospital for health care and emergency care of workers. Overall, the contractor should comply with IFS EHS Guidelines on Occupational Health and Safety.

7.3.4 Water right Conflict

98. The temporary settlement for the workers should be provided with temporary water taps. Open defecation should be controlled. Temporary toilets need to be constructed. Enhancement of Beneficial Impacts. Some of the beneficial impacts from the implementation of the project should be enhanced by;

- Community mobilization and people's participation in health and sanitation programs should be promoted,
- Training an awareness programs in health and uses of water and its importance (water cost, saving, reuse, recycle, water pollution etc.) should be given,
- Technical training to the local people on plumbing, chlorination, water testing, pump maintenance and repair should be conducted.

7.4 Activities for Rehabilitation Work and its Mitigation Measures

99. As this rehabilitation project is for previously implemented and operated in a satisfactory order with minimal rectification works. Physical, Biological and Social environment are described respectively in Section 7.1, 7.2 and 7.3. Slight changes are in social that is increased population, number of stakeholders for which additional distribution lines with ancillary works are to be done. Major focused were given for the technical rectification which need to be done during enhancement work are summarized in Table 7-1 in details. Most of the recommended mitigation measures will be incorporated in the contractual obligations and constructions works to be completed by the contractors. Facilities like water treatment plant, water testing laboratory etc are also either existing or to be installed is also included in the contract. Mitigation measures and monitoring plan of each rehabilitation activities is mentioned in Table 10-2, in Chapter 10.

Table 7-1: Activities for Rehabilitation Work

S.No	Name of Structure	Type	Existing Capacity(Q=lps, RVT=cum, WTP lps)	Design Capacity(lps)	Major problems	Required Intervention
I	Civil Structures					
1.a	System 1: KatuwaKhola	Surface Source	6.8			
1.b	System 2:KatuwaKhola	Surface Source	2.6			
1.c	System 3: KatuwaKhola	Surface Source	15			
1.d	System 4: TW 1	Pumping	5			
1.e	System 4: TW 2	Pumping	5			
1.e	System 4: TW 3	Pumping (Not Functioning)	5		• TW is damaged	• TW discarded. • 1 New TW is proposed of 11 lps
1.f	System 5: TW 1(JanakiTole)	Pumping	5			2 New TW is proposed of 11 lps.
1.g	System 5: TW 2(NawajyotiTole)	Pumping	5			
1.h	System 5: TW 3(Budhi Garage Tole)	Pumping	5			
1.i	System 5: TW 4(RatanpurTole)	Pumping	5			
1.j	System 5: TW 5 (ShryeKholaTole)	Pumping	5			
1.k	System 5: TW 6 (GuleriaTole)	Pumping	4			
1.l	System 5: TW 7(Office Compound)	Pumping	4			
	Total		72.4			
2.	Reservoir					
2.a	System 1: Ground Reserve Tank	RCC	50	50	Inadequate storage	• New RVT of 100 cum proposed.
2.b	System 1: Ground Reserve Tank	RCC	60	60	Inadequate storage	• New RVT of 25 cum proposed.
2.c	System 2: Ground Reserve Tank	RCC	25	25		

S.No	Name of Structure	Type	Existing Capacity(Q=lps, RVT=cum, WTP lps)	Design Capacity(lps)	Major problems	Required Intervention
2.d	System 2: Ground Reserve Tank	RCC	25	25		
2.e	System 3: Ground Reserve Tank	RCC	800	800		
2.f	System 4: OHT	RCC	300	300		
2.g	System 5: OHT	RCC	450	450	Inadequate storage for 2030	• New OHT of 450cum proposed.
3.	Treatment Plant	<ul style="list-style-type: none"> • SSF, HRF,PST- Total 9 numbers 3 in each scheme1,2,3 • PF and Aerator in Scheme no 4 and 5 				
3.a	SS#1	<ul style="list-style-type: none"> • Sedimentation Tank • Horizontal Roughing Filter • Slow Sand Filter 			<ul style="list-style-type: none"> • Filter media(Sand) is not as per specification • Often clogged SSF and HRF. 	<ul style="list-style-type: none"> • Filter media needs to be changed of SSF. • Media of HRF needs to be cleaned.
3.b	SS#2	<ul style="list-style-type: none"> • Sedimentation Tank • Horizontal Roughing Filter • Slow Sand Filter 			<ul style="list-style-type: none"> • Filter media(Sand) is not as per specification • Often clogged SSF and HRF. 	<ul style="list-style-type: none"> • Filter media needs to be changed. • Media of HRF needs to be cleaned.
3.c	SS#3	<ul style="list-style-type: none"> • Sedimentation Tank • Horizontal Roughing Filter • Slow Sand Filter 			<ul style="list-style-type: none"> • Filter media(Sand) is not as per specification • Often clogged SSF and HRF. 	<ul style="list-style-type: none"> • Filter media needs to be changed. • Media of HRF needs to be cleaned.
3.d	SS#4	<ul style="list-style-type: none"> • Aerator • Pressure Filter 			<ul style="list-style-type: none"> • Clogging of Aerator and 	<ul style="list-style-type: none"> • Cleaning works proposed.

S.No	Name of Structure	Type	Existing Capacity(Q=lps, RVT=cum, WTP lps)	Design Capacity(lps)	Major problems	Required Intervention
					Pressure	
3.e	SS#5	<ul style="list-style-type: none"> • Aerator • Pressure Filter 			<ul style="list-style-type: none"> • Clogging of Aerator and Pressure 	<ul style="list-style-type: none"> • Cleaning works proposed.
3.f	Chlorination				<ul style="list-style-type: none"> • Chlorination Unit not functioning well 	<ul style="list-style-type: none"> • 5 New Chlorination unit proposed.
4	Accessories, Valve Chambers etc	Valve Chamber, air valve, washout valve, NRV, Bulk Meters etc.			<ul style="list-style-type: none"> • Bulk meter are not functioning in all Systems • Lack of control valves in the DN. 	<ul style="list-style-type: none"> • 5 New Bulk meters proposed
5	Pipes and Pipe Fittings	HDPE, GI, DI			<ul style="list-style-type: none"> • Lack of Distribution network in different schemes 	<ul style="list-style-type: none"> • Need to lay additional distribution pipes lines in newly developed areas. • New pipeline of 3.028 km proposed

8. INFORMATION DISCLOSURE, CONSULTATION AND PARTICIPATION

8.1 Consultation

100. Stakeholder consultation and participation was an essential process in project preparation and this updated IEE. The process in engaging stakeholders and affected people during the conduct of the IEE involved key informant interviews, joint sites reconnaissance and on-site discussions with WUSC, and field random interview of stakeholders.

8.2 Initial consultation: the existing project

101. During the Feasibility Study, consultations were undertaken by the Design and Supervision Consultants. Stakeholder consultations have been continued through subprojects implementation and operation. All stakeholders were invited and encouraged to participate in community consultations. To facilitate the engagement of stakeholders, the PMO and RPMOs maintained good communication and collaboration with the WUSC and VDC. The PMO, RPMOS, Contractors and/or WUSC were opened to contact by the public on matters concerning the progress of the subprojects, adverse impacts, mitigation measures and environmental monitoring and grievances.

- Prior to construction, the PMO and TPO have conducted information, education and communication (IEC) campaign to ensure sufficient level of awareness/information among the affected communities regarding the upcoming construction, its anticipated impacts, the grievance redress mechanism, contact details and location of the PMO and TPO, and status of compliance with Government's environmental safeguard requirements, among others, are attained/provided. Billboards about the subproject, implementation schedule and contact details of the executing agency, PMO, TPO and Contractors have been set up at strategic locations within the subprojects' main areas of influence. The grievance redress procedure and details will have been posted at the offices of the PMO, TPO, WUSC and VDC.
- During construction, regular random interviews were conducted by the TPO every month to monitor environmental concerns of subproject communities.
- During operation, periodic random interviews were conducted by the PMO and
- TPO and WUSC to monitor the environmental concerns of sub project communities.

8.3 The consultation during IEE update

102. The consultation was done in two phases

8.3.1 Phase I

103. During the engineering survey and design phase, the consultations met with the top level management of DWSS, WUSC officials, WS division officials in Kathmandu and concerned municipality offices, WS customers and general public in field. The main persons consulted during this phase are listed below;

Table 8-1: Lists of People and Institutions Consulted

S No.	Name	Designation
1	Mr. Ram Deep Sah	Director General
2	Mr. Tires Prasad Khattrai	Acting Project Director
3	Mr. Dr. Mahesh Bhattra	PMC, Project Co-ordinator
4	Mr. Keshav Raj Bista	Deputy Project Director
5	Mr. Chudamani Pokhrel	WUSC Chairman at Site
6	Mr. Dev Bhdr. D.C.	Chairman
7	Mr. Govinda Prasad Sharma	Secretary
8	Mr. Nirja Pokhrel	Member
9	Mr. Sharda Thapa	Member

8.3.2 Phase II

104. After approval of Detail Design report, second level of public consultation was made to discussion issues regarding the environmental impact, resettlement, relocation and compensation with immediate stakeholders. Meeting was held on 2072/06/10 at site. In this phase overall project outcomes were discussed with all concerned stakeholders. Details of participants are presented in Annex 4.

8.4 Costs

105. All costs involved in resolving the complaints (meetings, consultations, communication and reporting/information dissemination) at local (field/ward/town) level will be borne by the concerned focal organizations at each level: WUSC at town level; PIU at regional level and PMO at central level.

9. GRIEVANCE REDRESS MECHANISM

9.1 Purpose of the Grievance Redress Mechanism

106. A project-specific grievance redress mechanism (GRM) will be established to receive, evaluate, and facilitate the resolution of APs' concerns, complaints, and grievances related to social and environmental issues of the project. The GRM will aim to provide a time-bound and transparent mechanism to voice and resolve social and environmental concerns linked to the project.

107. A common GRM will be in place for social, environmental, or any other grievances related to the project. The GRM will provide an accessible forum for receiving and facilitating resolution of affected persons' grievances related to the project. Every grievance shall be registered and careful documentation of process with regard to each grievance undertaken, as explained below. The environmental and social safeguards officer (ESO/SSO) at project management office (PMO) will have the overall responsibility for timely grievance redress on environmental and social safeguards issues. The Social Development Officer at the Regional Project Management Office (RPMO) will be the focal person for facilitating the grievance redress at VDC/Municipality level.

108. A town-level public awareness campaign will be conducted to ensure that awareness on the project and its grievance redress procedures is generated. The social safeguards expert of the project management consultant (PMC) and DSMC's safeguards specialists will support the WUSC and DSMC community mobilisers with information/collateral/awareness material etc. to conduct the town-wide awareness campaign. The campaign will ensure that the poor, vulnerable and others are made aware of grievance redress procedures and project's entitlements.

109. A Grievance Redress Committee (GRC) will be formed at VDC/Municipality level, comprising District Chief WSS as Chairperson and Member of Secretary of concerned WUSC as the GRC secretary. The GRC members will be comprise of (1) RPMO social development officer, (2) representatives of affected persons, (3) DSMC's safeguards specialist (social/environment as relevant), (4) a representative of reputable CBO/SHG/organization working in the project area, and (5) contractor's representative. The secretary of the GRC, who will be responsible for convening timely meetings and maintaining minutes of meetings. The concerned social safeguards expert of DSMC will support the RPMO SDO and Regional Director DWSS to ensure that grievances, including those of the poor and vulnerable are addressed. All GRCs shall have at least two women committee members. Representatives of APs, civil society and eminent citizens are to be invited as observers in GRC meetings.

110. The functions of the local GRC are as follows: (i) provide support to affected persons on problems arising from environmental or social disruption; asset acquisition (if necessary); and eligibility for entitlements, compensation and assistance; (ii) record grievances of affected persons, categorize and prioritize them and provide solutions within 15 days of receipt of complaint by WUSC; and (iii) ensure feedback to the aggrieved parties about developments regarding their grievances and decisions of the GRC. The grievance redress mechanism and procedure is depicted in Figure 9-1.

111. The GRM for the project is outlined below, with each step having time-bound schedules and responsible persons to address grievances and indicating appropriate persons whose advice is to be sought at each stage, as required:

9.1.1 First Level of GRM (WUSC-level)

112. The first level and most accessible and immediate venue for quick resolution of grievances will be the contractors, DSMC field engineers and PIU supervision personnel, who will immediately inform the WUSC. Any person with a grievance related to the project works can contact the Project to file a complaint. The WUSC will document the complaint within 24 hours of receipt of complaint in the field, and WUSC will immediately address and resolve the issue at field-level with the contractor, supervision personnel of PIU and DSMC field engineers within 5 days of receipt of a complaint/grievance. The assigned DSMC social mobilizer will be responsible to fully document: (i) name of the person, (ii) date of complaint received, (iii) nature of complaint, (iv) location and (v) how the complaint was resolved. If the complaint remains unresolved at the local level within 5 days, the WUSC will forward the complaint issue to the VDC/Municipality level GRM.

9.1.2 Second Level of GRM (VDC/Municipality level)

113. The complainant will be notified by the WUSC that the grievance is forwarded to the VDC/Municipality –level GRM. The Grievance Redress Committee (GRC) will be called for a meeting. The GRC meeting will be called and chaired by the District chief of WSS. The GRC will recommend corrective measures at the field level and assign clear responsibilities for implementing its decision within 10 days of receipt of complaint by WUSC. If the grievance remains unresolved within 10 days of receipt of complaint by WUSC, the matter will be referred to the third level. The RPMO SDO will be responsible for processing and placing all papers before the GRC, recording decisions, issuing minutes of the meetings and taking follow up action to see that formal orders are issued and the decisions carried out. If the complaints are related with IP/dalits/other vulnerable groups, specific NGO/CBO that actively involved in development of these communities should be involved.

9.1.3 Third Level of GRM (PMO Level)

114. Any unresolved or major issues at Municipality/VDC level will be referred to the PMO for final solution. The PMO’s Project Director and WUSC Union representative will have special meeting to find solution. Decision has to be made within 15 days of receipt of complaint by WUSC. The Project Director will sign off on all grievances received by the PMO. The environmental and social safeguards officers (ESO & SSO) will be involved with support from the PMC Social/Environment Safeguards Experts. The Project Director will sign off on all grievances received by the PMO. The PMO Safeguard Officer will be responsible to convey the final decision to the complainant.

115. All paperwork (details of grievances) needs to be completed by the WUSC member secretary and circulated to the WUSC Chairperson and members. At VDC/Municipality level, the VDC/Municipality SDO will be responsible for circulation of grievances to the Regional Director, DWSS and other GRC members, prior to the scheduled meetings. The PIU SDSO will be responsible for follow-through of all escalated grievances. All decisions taken by the GRC and PSC will be communicated to the APs by the PIU social development and safeguards officer.

116. Despite the project GRM, an aggrieved person shall have access to the country's legal system at any stage, and accessing the country's legal system can run parallel to accessing the GRM and is not dependent on the negative outcome of the GRM.

117. In the event that the established GRM is not in a position to resolve the issue, the affected person also can use the ADB Accountability Mechanism (AM) through directly contacting (in writing) the Complaint Receiving Officer (CRO) at ADB headquarters or the ADB Nepal Resident Mission. The complaint can be submitted in any of the official languages of ADB’s DMCs. The ADB Accountability Mechanism information will be included in the PID to be distributed to the affected communities, as part of the project GRM.

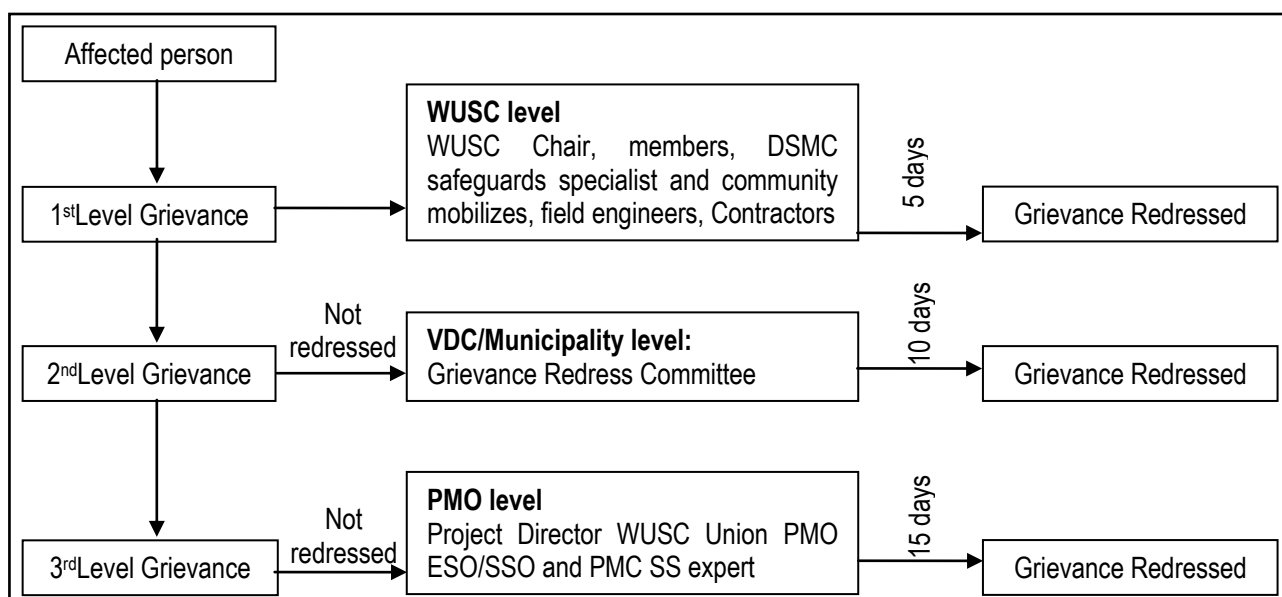

Figure 9-1: Grievance Redress Process

DSMC: Design, supervision and management consultant; ESO: Environmental and social safeguard officer;
 GRC: Grievance redress committee; PD: Project director; PMC: Project management consultant;
 PMO: Project management office; WUSC: Water user and sanitation committee.

Record keeping and disclosure

118. Records at the town-level will be kept by the concerned WUSC Member Secretary, of all grievances received, including contact details of complainant, date the complaint was received, nature of grievance, agreed corrective actions and the date of the incident and final outcome. The number of grievances recorded and resolved and the outcomes will be displayed/disclosed in the RPMO office, WUSC/municipal/VDC office, and on the web, as well as reported in the safeguards monitoring reports submitted to ADB on a semi-annual basis. For any grievance escalated to RPMO/VDC/Municipality level, the RPMO SDO will be responsible for record-keeping, calling of GRC meetings and timely sharing of information with WUSC. For grievances escalated to PMO and above, the PMO safeguard officers will be responsible for maintenance of records, sending copies to RPMO and WUSC for timely sharing of information with the person filing complaint.

119. Periodic review and documentation of lessons learned. The PMO social safeguard officer will periodically review the functioning of the GRM at town/WUSC level and PIU level and record information on the effectiveness of the mechanism, especially on the project’s ability to prevent and address grievances. Indicators pertaining to grievance redress (no. of grievances received, no. redressed/resolved) to be reported by Member Secretary, WUSC to PIU SDSO, and by PIU SDSO to PMO ESO in monthly progress reports.

Periodic review and documentation of lessons learned

120. The PMO social safeguard officer will periodically review the functioning of the GRM at town/WUSC level and PIU level and record information on the effectiveness of the mechanism, especially on the project’s ability to prevent and address grievances. Indicators pertaining to grievance redress (no. of grievances received, no. redressed/resolved) to be reported by Member Secretary, WUSC to PIU SDSO, and by PIU SDSO to PMO ESO in monthly progress reports.

Costs

121. All costs involved in resolving the complaints (meetings, consultations, communication and reporting/information dissemination) at local (field/ward/town) level will be borne by the concerned focal organizations at each level: WUSC at town level; PIU at regional level and PMO at central level. Cost estimates for grievance redress are included in EMP cost estimates.

10. ENVIRONMENT MANAGEMENT PLAN

122. The purpose of the environmental management plan (EMP) is to ensure that the activities are undertaken in a responsible, non-detrimental manner with the objectives of: (i) providing a proactive, feasible, and practical working tool to enable the measurement and monitoring of environmental performance on-site; (ii) guiding and controlling the implementation of findings and recommendations of the environmental assessment conducted for the project; (iii) detailing specific actions deemed necessary to assist in mitigating the environmental impact of the project; and (iv) ensuring that safety recommendations are complied with.

123. A copy of the EMP must be kept on work sites at all times. This EMP will be included in the bid documents and will be further reviewed and updated during implementation. The EMP will be made binding on all contractors operating on the site and will be included in the contractual clauses. Non-compliance with, or any deviation from, the conditions set out in this document constitutes a failure in compliance.

10.1 Institutional Arrangement

Executing and Implementing Agencies.

124. The Ministry of Water Supply and Sanitation (MoWSS) will be the executing agency with responsibility of subproject execution delegated to the Department of Water Supply and Sewerage (DWSS). The Water Supply and Sanitation Division/Sub-division Office (WSSDOs) are the subproject implementing agencies. Water Users' and Sanitation Committees of participating towns are the implementing agencies.

125. The key responsibilities of the executing and implementing agencies are as follows:

Prior to construction

- The MoWSS will deputize a qualified staff to act as the Environmental Safeguard Officer of the Project management office (PMO).
- The MUD will establish the grievance redress mechanism, including setting up the Grievance Redress Committee.
- The Water Supply and Environment Division of the MoWSS will be responsible for reviewing the IEE Report prior to submission to the Ministry of Science, Technology and Environment (MoSTE) for review and approval.
- The DWSS will review the IEE Report prepared by the Design and Supervision Consultants' Team's Environmental Safeguard Expert (DSMC-ESE) prior to forwarding this to MoWSS.
- The DWSS will prepare the ToRs for the Environmental Safeguard Specialist that will be engaged to support the PMO and for the Environmental Safeguard Specialists of the two Design and Supervision Consultants that will be appointed to prepare the subprojects.

During construction and operation

- The DWSS, through the PMO, will oversee the EARF and EMP implementation of all subprojects.
- The WSSDO, through the RPMOS, will oversee the EARF and EMP implementation at subproject/town level.

10.1.1 Safeguard Implementation Arrangement

Project Management Office (PMO)

126. The safeguard officers (environmental safeguard officer and social safeguard officer) of the PMO will receive support from the safeguards experts (environmental and social) of the Project Management Consultants (PMC) as specified below:

- i. confirm existing IEEs/EMPs are updated based on detailed designs and that new IEEs/EMPs are prepared in accordance with the EARF and government rules;
- ii. confirm whether EMPs are included in bidding documents and civil works contracts;
- iii. provide oversight on environmental management aspects of subprojects and ensure EMPs are implemented by regional project management offices (Eastern RPMO and Western RPMO) and contractors;

- iv. establish a system to monitor environmental safeguards of the project including monitoring the indicators set out in the monitoring plan of the EMP;
- v. facilitate and confirm overall compliance with all Government rules and regulations regarding site and environmental clearances as well as any other environmental requirements as relevant;
- vi. supervise and provide guidance to the RPMOs to properly carry out the environmental monitoring and assessments as per the EARF;
- vii. review, monitor and evaluate the effectiveness with which the EMPs are implemented, and recommend necessary corrective actions to be taken as necessary;
- viii. consolidate monthly environmental monitoring reports from RPMOs and submit semi-annual monitoring reports to ADB;
- ix. ensure timely disclosure of final IEEs/EMPs in project locations and in a form accessible to the public; and
- x. address any grievances brought about through the Grievance Redress Mechanism in a timely manner as per the IEEs.

Regional Project Management Offices (Eastern and Western RPMOs)

127. The regional DWSS engineers and social development officers of the RPMOs will receive support from; (i) the PMO safeguards officers (environmental and social); and (ii) the safeguards specialists (environmental and social), the social mobilizes and environmental management plan (EMP) monitors of the design, supervision and management consultant (DSMC) teams as specified below:

- i. prepare new IEEs/EMPs in accordance with the EARF and government rules;
- ii. include EMPs in bidding documents and civil works contracts;
- iii. comply with all government rules and regulations;
- iv. take necessary action for obtaining rights of way;
- v. oversee implementation of EMPs including environmental monitoring by contractors;
- vi. take corrective actions when necessary to ensure no environmental impacts;
- vii. submit monthly environmental monitoring reports to PMO, and;
- viii. address any grievances brought about through the Grievance Redress Mechanism in a timely manner as per the IEEs.

Civil Works Contracts and Contractors

128. EMP is to be included in bidding and contract documents and verified by the PMO and RPMOSs. The contractor will be required to designate an environment supervisor to ensure implementation of EMP during civil works. Contractors are to carry out all environmental mitigation and monitoring measures outlined in their contract. The government will ensure that bidding and contract documents include specific provisions requiring contractors to comply with all: (i) applicable labor laws and core labor standards on (a) prohibition of child labor as defined in national legislation for construction and maintenance activities, on (b) equal pay for equal work of equal value regardless of gender, ethnicity or caste, and on (c) elimination of forced labor; and (ii) the requirement to disseminate information on sexually transmitted diseases including HIV/AIDS to employees and local communities surrounding the project sites. Contractors will only start the civil works activities in the section/subproject sites that has IR/IPP impacts upon the completion of RP/IPP implementation and after receiving clearance from the WUSC and endorsed by RPMO's SDO.

Capacity Building

129. The PMC safeguards experts (environmental and social) will be responsible for training the; (i) PMO's safeguards officers (environmental and social); (ii) RPMOs' engineers and social development officers. Training modules will need to cover safeguards awareness and management in accordance with both ADB and government requirements as specified below:

- sensitization;
- introduction to environment and environmental considerations in water supply and wastewater projects;
- review of IEEs and integration into the project detailed design;
- improved coordination within nodal departments; and

- Monitoring and reporting system. The contractors will be required to conduct environmental awareness and orientation of workers prior to deployment to worksites.

Water Users and Sanitation Committees (WUSCs)

130. WUSCs are the eventual operators of the completed subprojects. The key tasks and responsibilities of the WUSCs are, but not limited to:

Prior to construction

- Facilitate public consultation and participation, information dissemination and social preparation.
- Provide available data to the DSMC-ESS during the conduct of the IEE.
- Assist in securing the tree-cutting permit and/or registration of water source.
- Participate in the capacity development program.

During construction

- Assist in the observance of the grievance redress mechanism.
- Actively participate in the monitoring of Contractor's compliance with the IEE and its EMP and the conditions set out with Government's approval of the IEE Reports.
- Facilitate public consultations, as necessary.

During operation

- Implement the EMP and the Water Safety Plan.
- Regularly monitor the water quality
- Prepare the environmental monitoring report as per IEE.
- Ensure observance of the grievance redress mechanism

Licensed and accredited laboratory

131. It is recommended that a licensed and accredited laboratory be engaged to conduct water quality monitoring in the first few years of operation and to train the WUSC on the same. The laboratory will ensure that while carrying out the water quality monitoring as prescribed in the National Drinking Water Quality Standard and its Directives, 'hands-on' training is provided to the WUSC.

10.1.2 Institutional Capacity Development Program

132. Considering the limited capability of the Project's key players in environmental management, technical assistance from environmental specialists and capacity development during loan implementation will be needed. Capacity development will consist of hands-on training in implementing the responsibilities in EMP (as well as in EARF) implementation, complemented with a short-term series of lectures/seminars on relevant topics.

133. WUSC does not have the capacity to monitor the quality of supplied water as prescribed in the NDWQS and its Directives. Albeit monitoring kits and laboratory rooms will be provided, this would not guarantee WUSC can handle monitoring appropriately. DWSS has five regional laboratories; however some are not functioning fully due to lack of manpower. Considering that public health is a critical concern associated with water supply, it is recommended that a licensed and accredited laboratory be engaged to conduct water quality monitoring for at least the first 2-3 years of operation with the WUSC actively participating to develop WUSC capacity. The conduct of water quality monitoring should be carried out in such a way that WUSC will be "learning by doing". After the engagement period, there should be continuing periodic training of new persons to ensure capacity of the WUSC is sustained. The cost for monitoring during operation is based on the assumption that a licensed laboratory will be engaged for both the monitoring requirements and to train the WUSC. A Water Safety Plan is included in subproject design and will oblige the operator to carry out water quality monitoring accordingly. The amount of NPR 500,000 will be provided annually to implement the Plan. There will be sufficient fund to include training by the licensed and accredited lab, while monitoring water quality.

134. The PMO will be responsible for trainings on environmental awareness and management in accordance with both ADB and government requirements. Specific modules customized for the available skill set will be devised after assessing the capabilities of the target participants and the

requirements of the project. Typical modules would be as follows: (i) sensitization; (ii) introduction to environment and environmental considerations in water supply and wastewater projects; (iii) review of IEEs and integration into the project detailed design; (iv) improved coordination within nodal departments; and (v) monitoring and reporting system. The contractors will be required to conduct environmental awareness and orientation of workers prior to deployment to work sites.

10.1.3 Staffing Requirement and Budget

135. Costs required for implementing the EMP will cover the following activities:

- i. Updating IEE, preparing and submitting reports and public consultation and disclosure;
- ii. Application for environmental clearances; and
- iii. Implementation of EMP, environmental monitoring program and long-term surveys.

136. The infrastructure involved in each scheme is generally straightforward to build. Environmental monitoring during construction will also be straightforward and will involve periodic site observations and interviews with workers and others, plus checks of reports and other documents. This will be conducted by PMO assisted by the PMO environmental safeguard officer. Therefore, no separate budget is required for the PMO.

137. The cost of mitigation measures and surveys during construction stage will be incorporated into the contractor's costs, which will be binding on him for implementation. The surveys will be conducted by the contractors.

138. The operation phase mitigation measures are again of good operating practices, which will be the responsibility of the WUSC. All monitoring during the operation and maintenance phase will be conducted by WUSC. The Water Safety Plan, included in each subproject design, will allocate NPR 500,000 annually for operation and maintenance particularly water quality monitoring. If a licensed laboratory will be engaged for the first 2-3 years of operation for training purposes, the cost can be accommodated under the Water Safety Plan.

10.2 Ministry of Water Supply and Sanitation Monitoring and Reporting

139. RPMOs will monitor and measure the progress of EMP implementation with assistance from DMSC. The monitoring activities will correspond with the project's risks and impacts, and will be identified in the IEE for the projects. In addition to recording

10.3 Environmental Monitoring Mechanism

140. Under the chairmanship of Ghorahi municipality, a Monitoring Committee should be formed. The committee should be represented by the chairman of concerned service wards of the VDC, representative from environment related NGOs, local community, Water Users' Committee and local entrepreneur. Secretary of the Ghorahi municipality should act as member secretary of the Monitoring Committee. This committee should be assigned following duties and responsibilities:

- The committee should meet at least twice a month;
- The committee should collect all complaints from the local people concerning distribution, pipeline etc and should discuss in the meeting for the final decisions;
- The monitoring committee should identify the mistakes and deficiency regarding the project and should discuss in the meeting for the purpose of correction;
- Any negligence regarding the water quality should be considered and take necessary action;
- The committee should also supervise and provide instructions for activities such as:
 - Distribution of qualitative water,
 - Storage of water in the reservoir tanks,
 - Treatment plant,
 - Handling of toxic/chemical matters,
 - Training for the locals, and
- Examine monitoring reports periodically and take necessary actions if required etc.

10.4 Monitoring Reporting Mechanism

141. As proposed by approved EMP, the reporting system should include site supervision and reporting as well and primarily connected with Monitoring plan. The construction contractors are

responsible for implementing approved EMP. The supervising consultants are responsible for monitoring to oversee whether or not the contractors have complied with the approved conditions as stated in EMP and also receive the monthly progress report from construction contractors. Based on this information the consulting engineers prepare the front line monitoring report and submit to DWSS for review

10.5 Monitoring Cost, Parameters, Location and Schedule

142. During rehabilitation, the cost for monitoring will be minimum and it should be allocated as and when required from the project contingency.

10.6 Contractors Compliance on EMP

143. The recommended mitigation measures are shown in the Table 10-1. The contractor should comply with the recommended mitigation activities.

10.7 Institutional Capacity Development Program

144. Considering the limited capability of the Project's key players in environmental management, technical assistance from environmental specialists and capacity development during loan implementation will be needed. Capacity development will consist of hands-on training in implementing the responsibilities in EMP (as well as in EARF) implementation, complemented with a short-term series of lectures/seminars on relevant topics.

145. In the Table 10-1 given below, the types of impact as predicted, corresponding mitigation measures, monitoring parameters, monitoring indicators, location and sources, responsibility and frequencies of monitoring have been included. The monitoring protocols given below are based on the Environmental Management Plan (IEE Ghorahi, 2005) approved by Government of Nepal 2005.

10.8 Environmental Mitigation Cost

146. Most of the recommended mitigation measures are incorporated in the contractual obligations and constructions works to be completed by the contractors. Facilities like water treatment plant, water testing laboratory etc are also either existing or to be installed is also included in the contract. Therefore mitigation cost of the enhancement project will be negligible. However in order to strengthen the existing facilities 2% of total project cost is proposed should be allocated.

Table 10-1: Mitigation measures and corresponding Monitoring plan

Impact and Mitigation Prescription		Monitoring Plan for Implementation						Status	
Environmental Impact	Mitigation action	Parameter to be Monitored	Indicators	Location	Sources	Responsibility	Frequency	Previous	Present ²
Physical Environment									
Construction Phase									
Land use pattern	Acquire only required land	Change in cropping pattern	Quality and quantity of yield	Project area	Local people	WUSC	Half yearly	Completed	Not applicable
Flooding and water stagnant	Drainage management	Observation of the project area	Increase in mosquito Increase in vector born diseases	Project area	Field inspection	DSC/Contractor	During and after monsoon	Completed	Recommended
	The excavated material must be safely disposed.	Ensure proper management of excessive spoil materials in place	Evidence of landscape erosion and river turbidity undisturbed	Project area	Field inspection	DSC/Contractor	After monsoon	Completed	Recommended
Impacts of sediments and Disinfecting Chemicals	Safe disposal	Water quality	Chemicals and pathogen exceeding national standards	Project area	Water quality test	DSC/Contractor	Quarterly	Completed	Recommended
Water Volume/Quality	Limited extraction/regular testing	Measurement of River flow and underground water table level	Change in quantity	Project area	River and ground water	DSC/Contractor	Quarterly	Completed	Recommended
Air Quality	Confine earthworks according to a staking plan and excavation segmentation plan and a part of the document	Visibility due to presence of dust	Location of stock pile	Project area	Local people and surrounding environment	DSC/Contractor	Twice in a week	Completed	Recommended

²Recommended for EMP compliance

Impact and Mitigation Prescription		Monitoring Plan for Implementation						Status	
Environmental Impact	Mitigation action	Parameter to be Monitored	Indicators	Location	Sources	Responsibility	Frequency	Previous	Present ²
		Amount of dust present in surrounding environment	Number of complaint from sensitive receptors	Project area	Local people and surrounding environment	Contractor	Twice in a week	Completed	Recommended
Acoustic environment	Restrict noisy activities to daytime. Overtime work should avoid using noisy/high noise generating equipment.	Sound intensity during day and night time	Number of complaints from sensitive receptors;	Project area	Local people and surrounding environment	Contractor	Twice in a week	Completed	Recommended
		Sound intensity at and nearby of source	Use of silencers in noise-producing equipment and sound barriers;	Project area	Local people and surrounding environment	Contractor	Twice in a week	Completed	Recommended
Traffic movement	Pipe line work need to be done during night and during less traffic time	Number of vehicles diverted	Number of vehicles movement	Project area	Local people and surrounding environment	WUSC/Contractor	During pipeline work	Completed	Recommended
Biological Environment									
Impact on natural vegetation and habitat	Construction area should be well demarked and proper instruction to be given for the workers.	Vegetation density, number and types of wild animals	Change in vegetation density and number of wild life	Project area	Project area	WUSC/Contractor	Quarterly	Completed	Recommended
Socio-economic and cultural environment									
Impairment to Infrastructure	Not applicable								
Land acquisition	Project has to make sure that adequate	Compensation measures	All affected	Project area	Records and Interview	WUSC/Contractor	Yearly	Completed	Completed

Impact and Mitigation Prescription		Monitoring Plan for Implementation						Status	
Environmental Impact	Mitigation action	Parameter to be Monitored	Indicators	Location	Sources	Responsibility	Frequency	Previous	Present ²
	compensation for the land acquired from private citizens (if required) is made								
Outside workforce conflict/ health/ pollution/ culture	Disease transmission, pollution and competition for the available resources to outsiders should be thoroughly checked.	Situation of social disharmony Awareness program	Decreased social disharmony Effective awareness program	Project area	Records and Interview	WUSC/Contractor	Yearly	Completed	Recommended
Operation Phase									
Water right Conflict	Public taps should be established in appropriate places.	Number of public taps installed	Adequate water supply to the public	Project area	Field inspection and Interview	WUSC	Quarterly	Completed	Recommended
Workers health and safety	Comply with requirements of Labor Act of GoN and standards on workers' health and safety (H&S).	Health of workers Dress and first-aid facilities stations	Site-specific H&S Plan	Project area	Workers health status and Interview	WUSC	Quarterly	Completed	Recommended
	Arrange for readily available first aid unit including an adequate supply of sterilized dressing materials and appliances	Health of workers Dress and first-aid facilities stations	Condition of sanitation facilities for workers	Project area	Workers health status and Interview	WUSC	Quarterly	Completed	Recommended

Source: IEE Ghorahi 2005

2. Recommended for EMP compliance

Table 10-2: Mitigation Measures and Monitoring Plan for Rehabilitation Activities

Overview of Impacts		Required mitigation measures			Monitoring plan for implementation				
Project activities	Possible impacts (on all baseline parameters)	Mitigation associated with project location	Mitigation in project design features	Residual mitigation measures (not addressed by location and design)	Parameter to be Monitored	Indicators	Location	Responsibility	Frequency
Water source									
No enhancement of reservoir	No significant impact								
Maintenance of existing tube well	No significant impact								
Construction of new tube well	Ground water reduction	Construction of ground water recharge pond			Water table level	Reduction in ground water level	site specific	Contractor and WUSC	During operation
Transmission line									
Enhancement not required	No any significant impact								
Treatment plant									
Installation of chlorination unit	Excessive use may be detrimental	Avoid excessive use							
	Leakage through storage	Maintain proper storage to avoid leakage			Chlorine contamination	Health problem in local people	Site specific	WUSC	Operation
Reservoir									
Construction of new reservoir	Impact of excavation of earth	Proper disposal of excavated materials and use of protection measures	Location of disposal site		Inspection of disposal site	Number of Land slides and erosion created by disposal	Site specific	Contractor	During construction
	Impact on land scaping and	Adequate excavation in			Landslide and slope stability	Increase in landslide and	Site specific	Contractor	During construction

Overview of Impacts		Required mitigation measures			Monitoring plan for implementation				
Project activities	Possible impacts (on all baseline parameters)	Mitigation associated with project location	Mitigation in project design features	Residual mitigation measures (not addressed by location and design)	Parameter to be Monitored	Indicators	Location	Responsibility	Frequency
	slope	proper way/ ownership				erosion			
Distribution line									
Network rehabilitation activities/ Additional distribution network	Traffic disturbance	Arrangement for traffic diversion with traffic	Traffic diversion		Arrangement of vehicular movement during construction	Smooth running of vehicles through diversion	Site specific	Contractor	During construction
	Air pollution	Dust reduction and emission should be controlled	Not applicable		Air quality	Particulate matter in air	Site specific	Contractor, WUSC and Locals	During construction
	HHs water distribution	Intermittent supply	Supply water through other sources		Water supply continued	Adequate amount of water supply in each households	Site specific	Contractor and WUSC	During construction
Electrical and mechanical repairment	Noise pollution and oil spillage	Sound muffler installed and proper management of waste oil	Not applicable		Sound level and amount of oil	Noise level emission standard	Site specific	Contractor	During construction

Note: Table 10-2 is prepared according to Table 7-1 of Chapter 7.

11. CONCLUSIONS AND RECOMMENDATIONS

147. The proposed subproject is not an environmentally critical undertaking. The IEE indicates that:

- The proposed subproject, its components, are not within or adjacent to environmentally sensitive areas.
- The extent of adverse impacts is expected to be local, confined within the subprojects' main areas of influence, quarry or borrowing sites, waste disposal sites, and the routes to and from these sites. Fine aggregates, sediments and/or wastes would not be transported beyond the aforementioned sites. With mitigation measures in place and ensuring that the bulk of earthworks are completed prior to the onset of the rainy season, the potential adverse impacts during construction would be highly/more site-specific.
- The few adverse impacts of high magnitude during construction will be temporary and short-term (i.e., most likely to occur only during peak construction period). These will not be sufficient to threaten or weaken the surrounding resources. The preparation and implementation of a Contractor's EMP that would address as minimum the requirements of the SPS-compliant subproject EMP will mitigate the impacts and lower their residual significance to acceptable levels. Simple/uncomplicated mitigation measures, basically integral to socially and environmentally responsible construction practices, are commonly used at construction sites and are known to Contractors. Hence, mitigation measures would not be difficult to design and institute.
- During operation, the potential delivery of unsafe water can be mitigated with good operation and maintenance, prompt action on leaks, and complying with the required quality monitoring of supplied water as prescribed in the National Drinking Water Quality Standards Directives.
- The proposed subproject will bring about: (i) the benefits of access to reliable supply of safe and potable water; (ii) promotion of good hygiene and sanitation practices and reduced health and safety risks as positive impacts; and (iii) enhanced public health, improved quality of life and safe communities as outcomes.

148. Based on the above findings, the classification of the 3rdSTWSSSP as Category B is confirmed, and no further special study or detailed EIA needs to be undertaken to comply with the Safeguard Policy Statement of the ADB. The Government of Nepal will incorporate the findings and recommendations of this IEE and prescribed environmental management in the EMP.

12. COMMENTS INCORPORATION MATRIX

Annexes

Annex 1: Project Location Map and Water Supply Plan

Annex 2: Water Tested Laboratory Analysis Report

Annex 3: Rapid Environmental Assessment (REA) Checklist

Annex 4: Minute of Meeting

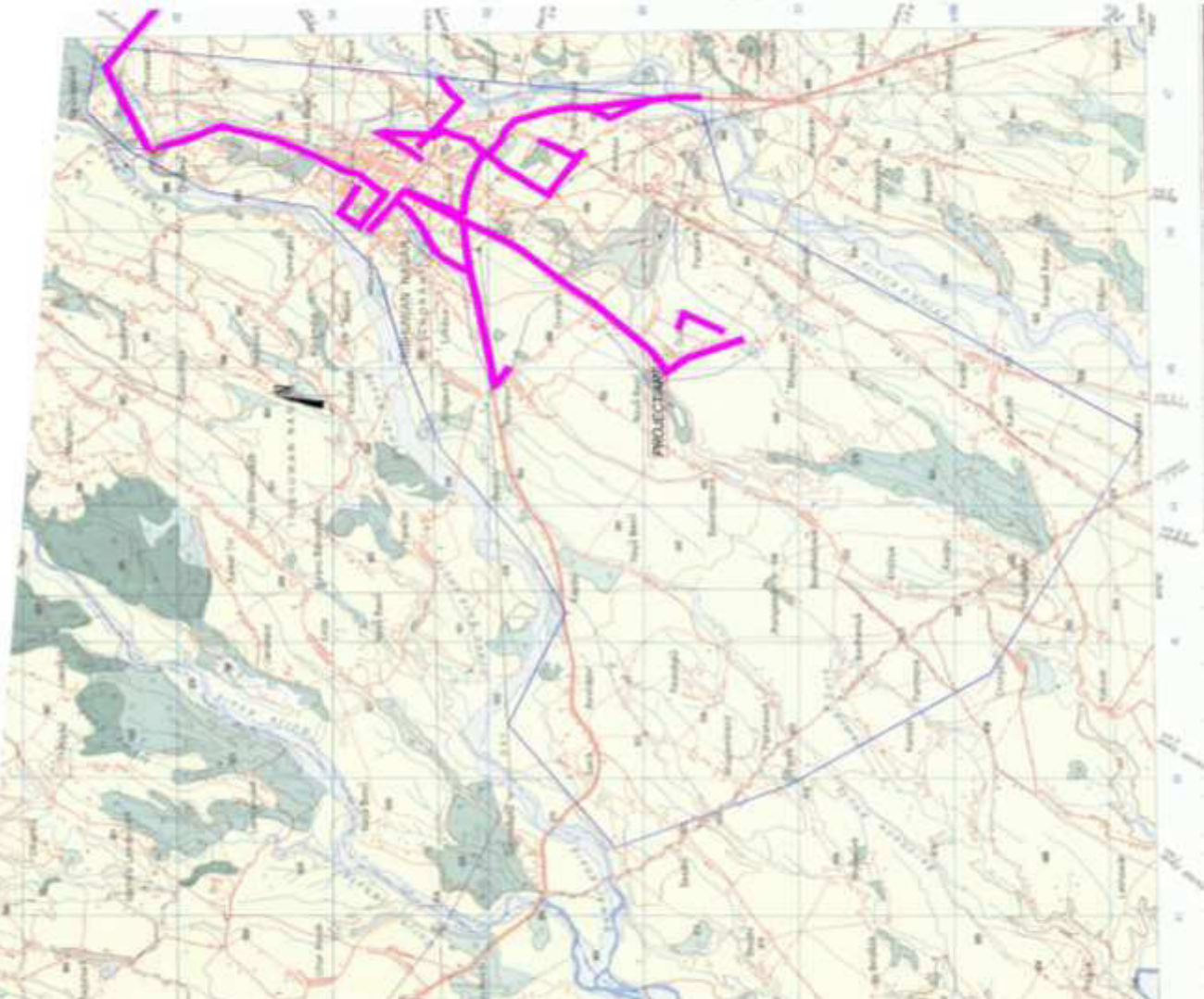

LEGEND

Highway with bridge	-----
Feeder road with bridge	-----
District road with bridge	-----
Other road with bridge	-----
Canal with bridge	-----
High level road with bridge	-----
Other level road with bridge	-----
Canal	-----
Channel	-----
Road with drainage and crossroads	-----
Topographic point, bench mark	•
Mountain peak, spot height	▲
Forest or wald	-----
Administrative boundary	-----
Custom boundary	-----
VIC or nationality boundary	-----
Range boundaries (contour lines)	-----
Section path boundary	-----

RVT-1



Existing RVT 2A

RVT 2B

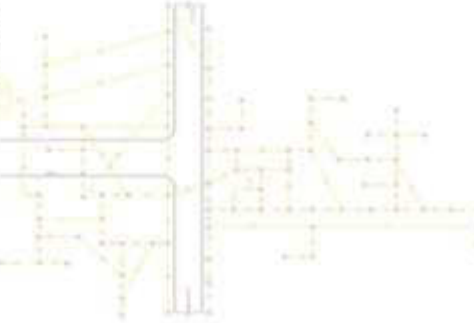

SURFACE SOURCE

PUMPING SOURCE

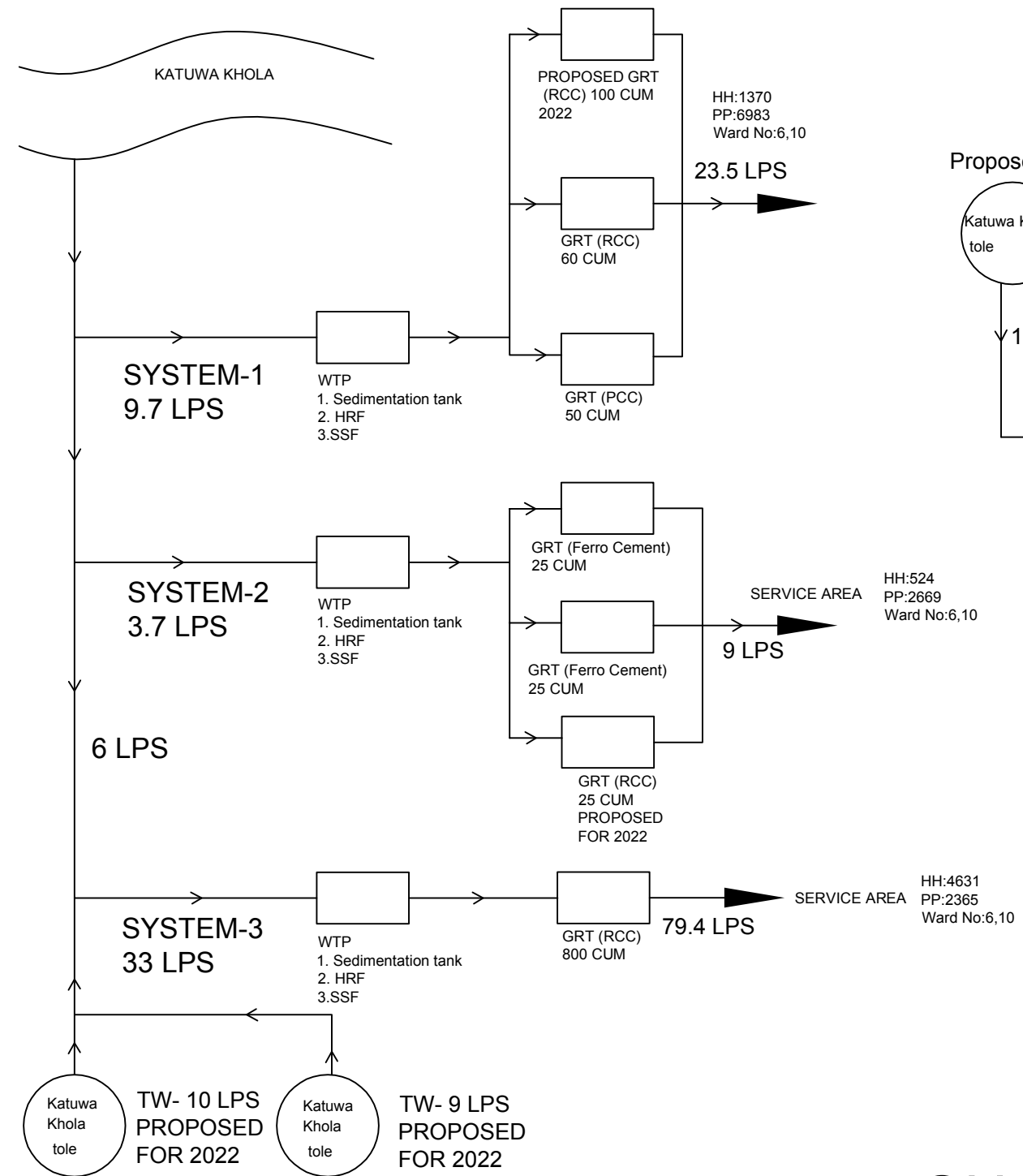

SYSTEM 4

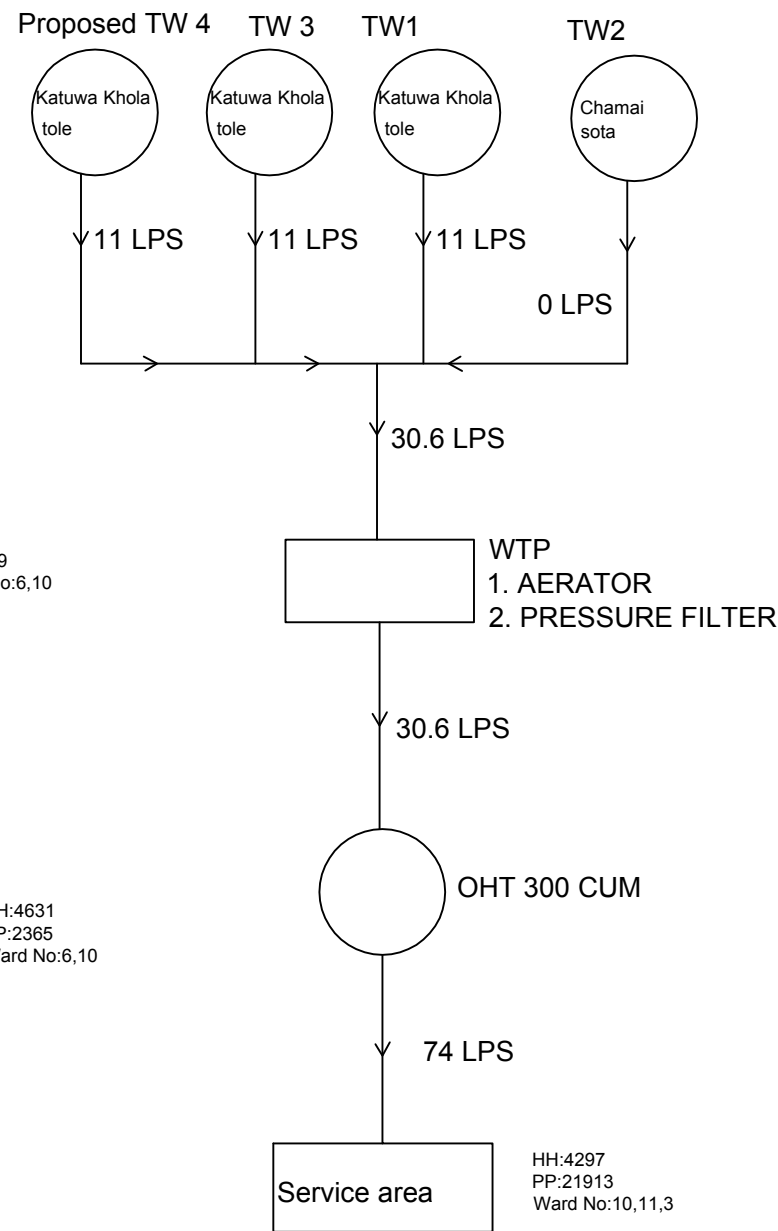

SYSTEM 5

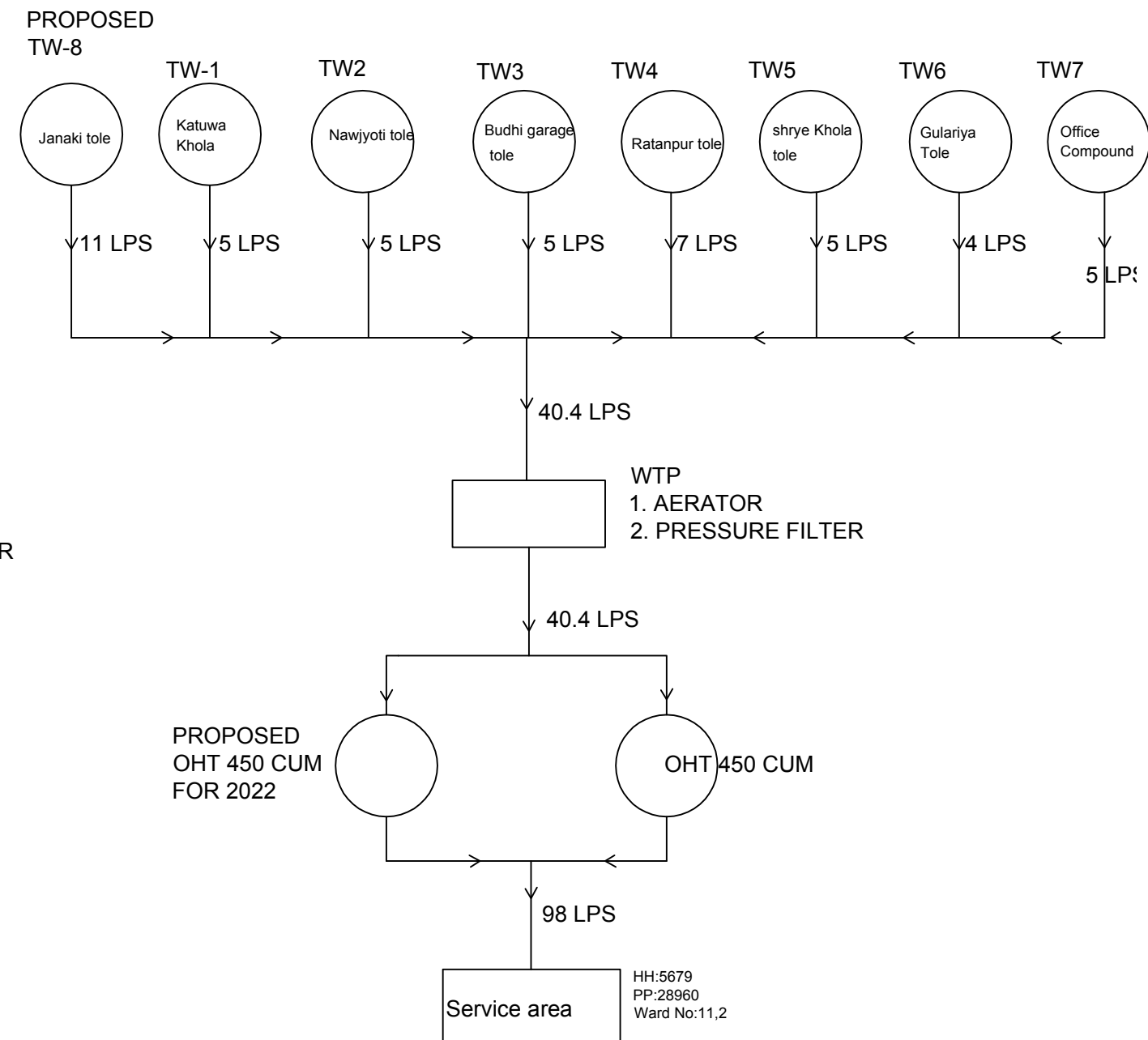

GHORAH, DANG

Annex - 2: Water Tested Laboratory Analysis Report



Water

Engineering & Training Centre (P.) Ltd.

Laboratory, R & D on Total Water Management, Treatment & Consultancy

LABORATORY ANALYSIS REPORT

Name of Sender: SILT ITEKO UNICORN JV		Name of Project: Ghorahi STWSSS		Date of Collection: 19/12/2014	
Sample No: SIU-1473/071/072		Type of Source: Groundwater		Sampling Point: WTP Inlet	
Date of Receipt: 19/12/2014		Name of Source: Bore Well (South)		Field Temperature (°C): 23.1	
Analyzed date : 21/12/2014-25/12/2014		No. of Samples: 01		Field pH: 7.7	
Sampled by : WETC		Location : Ghorahi		Field Electrical Conductivity (µS/cm) : 432.0	
Parameters	Units	WHO GV	NDWQS	Result	Methods used
PHYSICAL					
pH		6.5-8.5	6.5-8.5*	7.6	4500-H* B, APHA, 21 ST EDITION
Turbidity	NTU	5	5(10)	<1.0	2130 B, APHA, 21 ST EDITION
Electrical Conductivity	µS/cm	-	1500	432.0	2510 B, APHA, 21 ST EDITION
Lab Temperature	°C	-	-	18.4	2590 D, APHA, 21 ST EDITION
CHEMICAL					
Calcium	mg/l as Ca ²⁺	-	300	59.2	3500-Ca B, APHA, 21 ST EDITION
Magnesium	mg/l as Mg ²⁺	-	-	23.9	3500-Mg B, APHA, 21 ST EDITION
Total Hardness	mg/l as CaCO ₃	0.3	9.3(3)	0.07	3111 B, APHA, 21 ST EDITION
Manganese	mg/l as Mn	0.1	0.2	<0.01	3111 B, APHA, 21 ST EDITION
Arsenic	mg/l as As	0.01	0.05	<0.005	3114 C, APHA, 21 ST EDITION
Ammonia	mg/l as NH ₄ ⁺	1.5	1.5	<0.02	4500-NH ₄ C, APHA, 19 TH EDITION
Sodium	mg/l as Na ⁺	-	-	4.2	3111 B, APHA, 21 ST EDITION
Potassium	mg/l as K ⁺	-	-	0.46	3111 B, APHA, 21 ST EDITION
Total Chloride	mg/l as Cl ⁻	0.05	0.05	<0.01	3111 B, APHA, 21 ST EDITION
Total Alkalinity	mg/l as CaCO ₃	500	-	254.0	2520 B, APHA, 21 ST EDITION
Carbonate Alkalinity	mg/l as CaCO ₃	-	-	Nil	2520 B, APHA, 21 ST EDITION
Bicarbonate Alkalinity	mg/l as CaCO ₃	-	-	254.0	2520 B, APHA, 21 ST EDITION
Phosphate	mg/l as P	-	-	0.06	4500-PO ₄ B, APHA, 21 ST EDITION
Nitrate	mg/l as NO ₃ ⁻	50	50	2.5	4500-NO ₃ B, APHA, 21 ST EDITION
Nitrite	mg/l as NO ₂ ⁻	1	-	<0.02	4500-NO ₂ B, APHA, 21 ST EDITION
Sulfate	mg/l as SO ₄ ²⁻	250	250	<5.0	4500-SO ₄ B, APHA, 21 ST EDITION
Chloride	mg/l as Cl ⁻	250	250	6.9	4500-Cl B, APHA, 21 ST EDITION
Fluoride	mg/l as F ⁻	1.5	0.5-1.5*	0.11	4500-F D, APHA, 21 ST EDITION
Total Lead	mg/l as Pb	500	500	246.0	3340 C, APHA, 21 ST EDITION
Total Dissolved Solids	mg/l	1000	-	261.0	2540 C, APHA, 21 ST EDITION
Sampler Saturation Index	-	-	-	+0.2	2430 B, APHA, 21 ST EDITION
BIOLOGICAL					
Total Coliforms	CFU/100ml	Nil	Nil	Nil	9222 B, APHA, 21 ST EDITION
Faecal Coliform	CFU/100ml	Nil	Nil	Nil	9222 D, APHA, 21 ST EDITION

APHA, American Public Health Association, Standard Methods for the Examination of Water & Waste Water. WHO GV: World Health Organization Guidelines Value, 2006 Update. NDWQS: National Drinking Water Quality Standard, 2002 (Nepal). * These values show lower and upper limits. () Values in the parenthesis refers the acceptable values only when alternative is not available. **Not accredited Test Method

Comment: The tested parameters are within the permissible range as per NDWQS.

Antalya
Analyzed by

ll
Checked by

[Signature]
Authorized Signature

- Note: 1. The result refer only to the parameters tested of the samples provided to our laboratory or collected by us for analysis as specified. Endorsement of the product is neither inferred nor implied.
 2. Any duplication of this report can not be used as evidence in the court of law and should not be used in any advertising media without prior written permission to us.
 3. The total liability of our company for the product is limited to the invoiced amount only.



Water

Engineering & Training Centre (P.) Ltd.

Laboratory, R & D on Total Water Management, Treatment & Consultancy

LABORATORY ANALYSIS REPORT

Parameters	Units	WHO GV	NDWQS	Result	Methods used
PHYSICAL					
pH		6.5-8.5	6.5-8.5*	7.5	4500-H ⁺ B, APHA, 21 st EDITION
Turbidity	NTU	5	5 (10)	<1.0	2120 B, APHA, 21 st EDITION
Electrical Conductivity	$\mu\text{S/cm}$	-	1500	434.0	2510 B, APHA, 21 st EDITION
Lab Temperature	°C	-	-	18.5	2550 B, APHA, 21 st EDITION
CHEMICAL					
Calcium	mg/L as Ca ²⁺	-	200	59.2	3500-Ca B, APHA, 21 st EDITION
Magnesium	mg/L as Mg ²⁺	-	-	23.9	3500-Mg B, APHA, 21 st EDITION
Iron	mg/L as Fe	0.3	0.3 (3)	<0.01	3111 B, APHA, 21 st EDITION
Manganese	mg/L as Mn	0.4	0.2	<0.01	3111 B, APHA, 21 st EDITION
Arsenic	mg/L as As	0.01	0.05	<0.005	3114 C, APHA, 21 st EDITION
Ammonia	mg/L as NH ₄ ⁺	1.5	1.5	<0.02	4500-NH ₄ C, APHA, 21 st EDITION
Sodium	mg/L as Na	-	-	4.2	3111 F, APHA, 21 st EDITION
Potassium	mg/L as K ⁺	-	-	0.42	3111 B, APHA, 21 st EDITION
Total Chloride	mg/L as Cl ⁻	0.05	0.05	<0.01	3111 B, APHA, 21 st EDITION
Total Alkalinity	mg/L as CaCO ₃	500	-	252.0	2320 B, APHA, 21 st EDITION
Carbonate Alkalinity	mg/L as CaCO ₃	-	-	Nil	2320 B, APHA, 21 st EDITION
Bi-Carbonate Alkalinity	mg/L as CaCO ₃	-	-	252.0	2320 B, APHA, 21 st EDITION
Orthophosphate	mg/L as P	-	-	0.06	4500-PO ₄ B, APHA, 21 st EDITION
Nitrate	mg/L as NO ₃	50	50	2.4	4500-NO ₃ B, APHA, 21 st EDITION
Nitrite	mg/L as NO ₂	3	-	<0.02	4500-NO ₂ B, APHA, 21 st EDITION
Sulphate	mg/L as SO ₄	250	250	<5.0	4500-SO ₄ B, APHA, 21 st EDITION
Chloride	mg/L as Cl ⁻	250	250	11.8	4500-Cl B, APHA, 21 st EDITION
Fluoride	mg/L as F ⁻	1.5	0.5-1.5*	0.10	4500-F D, APHA, 21 st EDITION
Total Hardness	mg/L as CaCO ₃	500	500	246.0	2310 C, APHA, 21 st EDITION
Total Dissolved Solids	mg/L	1000	-	263.0	2540 C, APHA, 21 st EDITION
Laugher Saturation Index		-	-	-0.3	2530 B, APHA, 21 st EDITION
BIOLOGICAL					
Total Coliforms	CFU/100ml	Nil	Nil	Nil	9222 B, APHA, 21 st EDITION
Faecal Coliform	CFU/100ml	Nil	Nil	Nil	9222 D, APHA, 21 st EDITION

APHA: American Public Health Association, Standard Methods for the Examination of Water & Waste Water, WHO GV: World Health Organization Guideline Value, 2006 Update, NDWQS: National Drinking Water Quality Standard, 2062 (Nepal). * These values show lower and upper limits. () Values in the parenthesis refers the acceptable values only when alternative is not available. **Not accredited Test Method

Comment: The tested parameters are within the permissible range as per NDWQS.

Analysed by

Checked by

Authorized Signature

- Note: 1. The result refer only to the parameters tested of the samples provided to our laboratory or collected by us for analysis as specified. Endorsement of the product is neither inferred nor implied.
2. Any duplication of this report can not be used as evidence in the court of law and should not be used in any advertising media without prior written permission to us.
3. The total liability of our company for the product is limited to the invoiced amount only.



Water

Engineering & Training Centre (P.) Ltd.

Laboratory, R & D on Total Water Management, Treatment & Consultancy

LABORATORY ANALYSIS REPORT

Parameters	Units	WHO GV	NDWQS	Result	Methods used
PHYSICAL					
pH	-	6.5-8.5	6.5-8.5*	7.5	4500-H, APHA, 21 ST EDITION
Turbidity	NTU	5	5(10)	<1.0	2130 B, APHA, 21 ST EDITION
Electric Conductivity	μ S/cm	-	1500	395.0	2510 B, APHA, 21 ST EDITION
Lab Temperature	$^{\circ}$ C	-	-	18.5	2550 B, APHA, 21 ST EDITION
CHEMICAL					
Calcium	mg/L as Ca ²⁺	-	200	48.8	4500-Ca B, APHA, 21 ST EDITION
Magnesium	mg/L as Mg	-	-	22.9	4520-Mg B, APHA, 21 ST EDITION
Iron	mg/L as Fe	0.3	0.3(3)	<0.01	3111 B, APHA, 21 ST EDITION
Manganese	mg/L as Mn	0.4	0.2	<0.01	3111 B, APHA, 21 ST EDITION
Arsenic	mg/L as As	0.01	0.05	<0.005	2114 C, APHA, 21 ST EDITION
Ammonia	mg/L as NH ₃	1.5	1.5	<0.02	4500-NH ₃ C, APHA, 17 TH EDITION
Sodium	mg/L as Na ⁺	-	-	2.4	3111 B, APHA, 21 ST EDITION
Potassium	mg/L as K ⁺	-	-	0.46	3111 B, APHA, 21 ST EDITION
Total Chromium	mg/L as Cr	0.05	0.05	<0.01	3111 B, APHA, 21 ST EDITION
Total Alkalinity	mg/L as CaCO ₃	500	-	234.0	2320 B, APHA, 21 ST EDITION
Carbonate Alkalinity	mg/L as CaCO ₃	-	-	Nil	2320 B, APHA, 21 ST EDITION
Bicarbonate Alkalinity	mg/L as CaCO ₃	-	-	234.0	2320 B, APHA, 21 ST EDITION
Phosphate	mg/L as P	-	-	0.06	4500-P F, APHA, 21 ST EDITION
Nitrate	mg/L as NO ₃	50	50	2.2	4500-NO ₃ -B, APHA, 21 ST EDITION
Nitrite	mg/L as NO ₂	3	-	<0.02	4500-NO ₂ -B, APHA, 21 ST EDITION
Sulphate	mg/L as SO ₄	250	250	<5.0	4500-SO ₄ APHA, 21 ST EDITION
Chloride	mg/L as Cl ⁻	250	250	6.9	4500-Cl B, APHA, 21 ST EDITION
Fluoride	mg/L as F ⁻	1.5	0.5-1.5*	0.18	4500-F D, APHA, 21 ST EDITION
Total Hardness	mg/L as CaCO ₃	500	500	228.0	2340 C, APHA, 21 ST EDITION
Total Dissolved Solids	mg/L	1000	-	239.0	2540 C, APHA, 21 ST EDITION
Langmuir Saturation Index	-	-	-	-0.5	2316 B, APHA, 21 ST EDITION
BIOLOGICAL					
Total Coliforms	CFU/100ml	Nil	Nil	300	9223 B, APHA, 21 ST EDITION
Faecal Coliforms	CFU/100ml	Nil	Nil	46	9222 B, APHA, 21 ST EDITION

APHA: American Public Health Association, Standard Method: for the Examination of Water & Waste Water, WHO GV: World Health Organization Guideline Value, 2008 Update, NDWQS: National Drinking Water Quality Standard, 2052 (Nepal). * These values show lower and upper limits. () Values in the parenthesis refers the acceptable values only when alternative is not available. ** Not accredited Test Method

Comment: The tested parameters are within the permissible range as per NDWQS. Bacteriologically, unsatisfactory.

Analysed by

Checked by

Authorized Signature

Nepal Laboratory Accreditation Scheme

Note: 1. The results refer only to the parameters tested of the samples provided to our laboratory or collected by us for analysis as specified. Endorsement of the product is neither intended nor implied.
2. Any application of this report can not be used as evidence in the court of law and should not be used in any advertising media without prior written permission to us.
3. The total liability of our company for the product is limited to the invoiced amount only.



Water

Engineering & Training Centre (P.) Ltd.

Laboratory, R & D on Total Water Management, Treatment & Consultancy

LABORATORY ANALYSIS REPORT

Parameters	Units	WHO GV	NDWQS	Result	Methods used
PHYSICAL					
pH	-	6.5-8.5	6.5-8.5*	7.6	4500-B, APHA, 21 ST EDITION
Turbidity	NTU	5	5(10)	<1.0	2120 B, APHA, 21 ST EDITION
Electrical Conductivity	µS/cm	-	1500	398.0	2510 B, APHA, 21 ST EDITION
Lab Temperature	°C	-	-	18.4	2550 A, APHA, 21 ST EDITION
CHEMICAL					
Calcium	mg/L as Ca ²⁺	-	200	48.8	3500-C, APHA, 21 ST EDITION
Magnesium	mg/L as Mg ²⁺	-	-	22.9	3500-Mg, APHA, 21 ST EDITION
Iron	mg/L as Fe	0.3	0.3(0.5)	<0.01	3113 B, APHA, 21 ST EDITION
Manganese	mg/L as Mn	0.4	0.2	<0.01	3111 B, APHA, 21 ST EDITION
Arsenic	mg/L as As	0.01	0.05	<0.005	3114 C, APHA, 21 ST EDITION
Ammonia	mg/L as NH ₄ ⁺	1.5	1.5	<0.02	4500-NH ₄ -C, APHA, 17 TH EDITION
Sodium	mg/L as Na	-	-	2.5	3111 B, APHA, 21 ST EDITION
Potassium	mg/L as K ⁺	-	-	0.44	3111 B, APHA, 21 ST EDITION
Total Chromium	mg/L as Cr	0.05	0.05	<0.01	3111 B, APHA, 21 ST EDITION
Total Alkalinity	mg/L as CaCO ₃	500	-	232.0	2320 B, APHA, 21 ST EDITION
Carbonate Alkalinity	mg/L as CaCO ₃	-	-	Nil	2320 B, APHA, 21 ST EDITION
Bicarbonate Alkalinity	mg/L as CaCO ₃	-	-	232.0	2320 B, APHA, 21 ST EDITION
Phosphate	mg/L as P	-	-	0.05	4500-P E, APHA, 21 ST EDITION
Nitrate	mg/L as NO ₃	50	50	2.4	4500-NO ₃ -B, APHA, 21 ST EDITION
Nitrite	mg/L as NO ₂	3	-	<0.02	4500-NO ₂ -B, APHA, 21 ST EDITION
Sulfate	mg/L as SO ₄	250	250	<5.0	4500-SO ₄ , APHA, 21 ST EDITION
Chloride	mg/L as Cl ⁻	250	250	7.8	4500-Cl ⁻ B, APHA, 21 ST EDITION
Fluoride	mg/L as F ⁻	1.5	0.5-1.5*	0.16	4500-F-D, APHA, 21 ST EDITION
Total Hardness	mg/L as CaCO ₃	500	500	238.0	2440 C, APHA, 21 ST EDITION
Total Dissolved Solids	mg/L	1000	-	240.0	2540 C, APHA, 21 ST EDITION
Langlier Saturation Index	-	-	-	-0.4	2530 B, APHA, 21 ST EDITION
BIOLOGICAL					
Total Coliforms	CFU/100ml	Nil	Nil	16	9227 B, APHA, 21 ST EDITION
Faecal Coliform	CFU/100ml	Nil	Nil	Nil	9227 B, APHA, 21 ST EDITION

APHA: American Public Health Association, Standard Methods for the Examination of Water & Waste Water, WHO GV: World Health Organization Guideline Value, 2006 Update, NDWQS: National Drinking Water Quality Standard, 2062 (Nepal). * These values show lower and upper limits. () Values in the parenthesis refers the acceptable values only when alternative is not available. **Not accredited Test Method

Comment: The tested parameters are within the permissible range as per NDWQS. Bacteriologically, unsatisfactory.

Analysed by

Checked by

Authorized Signature

- Note:
- The results refer only to the parameters tested of the samples provided to our laboratory or collected by us for analysis as specified. Endorsement of the product is neither inferred nor implied.
 - Any duplication of this report can not be used as evidence in the court of law and should not be used in any advertising media without prior written permission to us.
 - The total liability of our company for the product is limited to the invoiced amount only.



Water

Engineering & Training Centre (P.) Ltd.

Laboratory, R & D on Total Water Management, Treatment & Consultancy

LABORATORY ANALYSIS REPORT

Name of Sender: SIIU ITEKO UNICORN JV	Name of Project: Ghorahi STWSSS	Date of Collection: 19/12/2014
Sample No: SIIU-1477/071/072	Type of Source: Surface & Ground Water (Mixed)	Sampling Point: End Tap (Highway South)
Date of Receipt: 19/12/2014	Name of Source: Katuwa Khola	Field Temperature (°C): 18.9
Analyzed date: 21/12/2014-23/12/2014	No. of Samples: 01	Field pH: 7.6
Sampled by: WETC	Location: Ghorahi	Field Electrical Conductivity (µS/cm): 418.0

Parameters	Units	WHO GV	NDWQS	Result	Methods used
PHYSICAL					
pH	-	6.5-8.5	6.5-8.5*	7.5	4500-H ⁺ B, APHA, 21 ST EDITION
Turbidity	NTU	5	5 (10)	<1.0	2130 B, APHA, 21 ST EDITION
Electrical Conductivity	µS/cm	-	1500	418.0	2550 B, APHA, 21 ST EDITION
Lab Temperature	°C	-	-	18.5	2550 B, APHA, 21 ST EDITION
CHEMICAL					
Calcium	mg/L as Ca ²⁺	-	200	49.0	3500-Ca B, APHA, 21 ST EDITION
Magnesium	mg/L as Mg ²⁺	-	-	27.7	3500-Mg B, APHA, 21 ST EDITION
Iron	mg/L as Fe	0.3	0.3(3)	0.04	3111 B, APHA, 21 ST EDITION
Manganese	mg/L as Mn	0.4	0.2	<0.01	3111 B, APHA, 21 ST EDITION
Arsenic	mg/L as As	0.01	0.05	<0.005	3111 C, APHA, 21 ST EDITION
Ammonia	mg/L as NH ₄ ⁺	1.5	1.5	<0.02	4500-NH ₄ C, APHA, 17 TH EDITION
Sodium	mg/L as Na ⁺	-	-	2.8	3111 B, APHA, 21 ST EDITION
Potassium	mg/L as K ⁺	-	-	0.54	3111 B, APHA, 21 ST EDITION
Total Chlorine	mg/L as Cl ⁻	0.05	0.05	<0.01	3111 B, APHA, 21 ST EDITION
Total Alkalinity	mg/L as CaCO ₃	500	-	242.0	2320 B, APHA, 21 ST EDITION
Carbonate Alkalinity	mg/L as CaCO ₃	-	-	Nil	2320 B, APHA, 21 ST EDITION
Bicarbonate Alkalinity	mg/L as CaCO ₃	-	-	242.0	2320 B, APHA, 21 ST EDITION
Phosphate	mg/L as P	-	-	0.05	4500-PO ₄ B, APHA, 21 ST EDITION
Nitrate	mg/L as NO ₃ ⁻	50	50	2.4	4500-NO ₃ -B, APHA, 21 ST EDITION
Nitrite	mg/L as NO ₂ ⁻	3	-	<0.02	4500-NO ₂ -B, APHA, 21 ST EDITION
Sulphate	mg/L as SO ₄ ²⁻	250	250	<5.0	4500-SO ₄ B, APHA, 21 ST EDITION
Chloride	mg/L as Cl ⁻	250	250	5.6	4500-CL B, APHA, 21 ST EDITION
Fluoride	mg/L as F ⁻	1.5	0.5-1.5*	0.14	4500-F D, APHA, 21 ST EDITION
Total Hardness	mg/L as CaCO ₃	500	500	236.0	2140 C, APHA, 21 ST EDITION
Total Dissolved Solids	mg/L	1000	-	255.0	2540 C, APHA, 21 ST EDITION
Langelier Saturation Index	-	-	-	-0.4	2130 B, APHA, 21 ST EDITION
BIOLOGICAL					
Total Coliforms	CFU/100ml	Nil	Nil	28	9222 B, APHA, 21 ST EDITION
Faecal Coliforms	CFU/100ml	Nil	Nil	Nil	9222 D, APHA, 21 ST EDITION

APHA: American Public Health Association, Standard Methods for the Examination of Water & Waste Water WHO GV: World Health Organization Guidelines, Vol. 2, 2006 Update, NDWQS: National Drinking Water Quality Standard, 2062 (Nepal), * These values show lower and upper limits, () Values in the parenthesis refers the acceptable values only when alternative is not available, ** Not accredited Test Method

Comment: The tested parameters are within the permissible range as per NDWQS. Bacteriologically, unsatisfactory.

Analyzed by

Checked by

Authorized Signature

- Note: 1. The result refers only to the parameters tested of the samples provided to our laboratory or collected by us for analysis as specified. Enforcement of the product is neither inferred nor implied.
2. Any duplication of this report can not be used as evidence in the court of law and should not be used in any advertising media without prior written permission to us.
3. The total liability of our company for the product is limited to the invoiced amount only.

**Annex - 3: Rapid Environment Assessment
(REA) Checklist**

ADB'S REA Checklist

Rapid Environmental Assessment (REA) Checklist

WATER SUPPLY

Instructions:

- This checklist is to be prepared to support the environmental classification of a project. It is to be attached to the environmental categorization form that is to be prepared and submitted to the Chief Compliance Officer of the Regional and Sustainable Development Department.
- This checklist is to be completed with the assistance of an Environment Specialist in a Regional Department.
- This checklist focuses on environmental issues and concerns. To ensure that social dimensions are adequately considered, refer also to ADB checklists and handbooks on (i) Involuntary resettlement, (ii) Indigenous peoples planning, (iii) Poverty reduction, (iv) Participation, and (v) Gender and development.
- Answer the questions assuming the "without mitigation" case. The purpose is to identify potential impacts. Use the "remarks" section to discuss any anticipated mitigation measures.

Country/Project Title: Tribhuvan Nagar (Ghorahi) Small Town Water Supply Rehabilitation Sub-Project, Dang

Sector Division: Water Supply

SCREENING QUESTIONS	Yes	No	REMARKS
A. Project Siting Is the project area ...			
• Densely populated?	<input type="checkbox"/>	<input checked="" type="checkbox"/>	
• Heavy with development activities?	<input type="checkbox"/>	<input checked="" type="checkbox"/>	Major occupation is agriculture followed by business
• Adjacent to or within any environmentally sensitive areas?			
• Cultural heritage site	<input type="checkbox"/>	<input checked="" type="checkbox"/>	The subproject components are not within locations in or near sensitive and vulnerable ecosystems and protected areas.
• Protected area	<input type="checkbox"/>	<input checked="" type="checkbox"/>	
• Wetland	<input type="checkbox"/>	<input checked="" type="checkbox"/>	
• Mangrove	<input type="checkbox"/>	<input checked="" type="checkbox"/>	
• Estuarine	<input type="checkbox"/>	<input checked="" type="checkbox"/>	
• Buffer zone of protected area	<input type="checkbox"/>	<input checked="" type="checkbox"/>	
• Special area for protecting biodiversity	<input type="checkbox"/>	<input checked="" type="checkbox"/>	
• Bay	<input type="checkbox"/>	<input checked="" type="checkbox"/>	
B. Potential Environmental Impacts Will the Project cause ...			
• Pollution of raw water supply from upstream wastewater discharge from communities, industries, agriculture, and soil erosion runoff?	<input type="checkbox"/>	<input checked="" type="checkbox"/>	<ul style="list-style-type: none"> • Deep Boring (Lohasur and Rajhena) • Reservoir (Katuwa Khola)
• Impairment of historical/cultural monuments/areas and loss/damage to these sites?	<input type="checkbox"/>	<input checked="" type="checkbox"/>	Absence of historical monuments
• Hazard of land subsidence caused by excessive ground water pumping?	<input type="checkbox"/>	<input checked="" type="checkbox"/>	Excessive pumping should be controlled
• Social conflicts arising from displacement of communities?	<input type="checkbox"/>	<input checked="" type="checkbox"/>	Not anticipated. The proposed sites of the deep tube well and new overhead tank will not require acquisition of private land. There are no encroachers/squatters or

SCREENING QUESTIONS	Yes	No	REMARKS
			residential/commercial structures at the proposed sites where infrastructure is to be established.
• Conflicts in abstraction of raw water for water supply with other beneficial water uses for surface and ground waters?	<input type="checkbox"/>	<input checked="" type="checkbox"/>	Not anticipated. Water quantity is sufficient.
• Unsatisfactory raw water supply (e.g. excessive pathogens or mineral constituents)?	<input checked="" type="checkbox"/>	<input type="checkbox"/>	Arsenic problem occurs in the area, a health hazard
• Delivery of unsafe water to distribution system?	<input checked="" type="checkbox"/>	<input type="checkbox"/>	Can be mitigated
• Inadequate protection of intake works or wells, leading to pollution of water supply?	<input checked="" type="checkbox"/>	<input type="checkbox"/>	Can be mitigated
• Over pumping of ground water, leading to salinization and ground subsidence?	<input type="checkbox"/>	<input checked="" type="checkbox"/>	High cost involved in pumping will constrain over pumping. EMP recommends monitoring pumping & maintaining record to control pumping to design limit.
• Excessive algal growth in storage reservoir?	<input checked="" type="checkbox"/>	<input type="checkbox"/>	Treatment will come in existence
• Increase in production of sewage beyond capabilities of community facilities?	<input checked="" type="checkbox"/>	<input type="checkbox"/>	Can be mitigated
• Inadequate disposal of sludge from water treatment plants?	<input checked="" type="checkbox"/>	<input type="checkbox"/>	Can be mitigated
• Inadequate buffer zone around pumping and treatment plants to alleviate noise and other possible nuisances and protect facilities?	<input type="checkbox"/>	<input checked="" type="checkbox"/>	Groundwater pumps are submersible and all other pump equipment in the water treatment plan will be housed in a pump shed.
• Impairments associated with transmission lines and access roads?	<input checked="" type="checkbox"/>	<input type="checkbox"/>	Minor and temporary impact
• Health hazards arising from inadequate design of facilities for receiving, storing, and handling of chlorine and other hazardous chemicals.	<input checked="" type="checkbox"/>	<input type="checkbox"/>	To be consider in design stage
• Health and safety hazards to workers from the management of chlorine used for disinfection and other contaminants?	<input checked="" type="checkbox"/>	<input type="checkbox"/>	Training for operator to be provided
• Dislocation or involuntary resettlement of people	<input type="checkbox"/>	<input checked="" type="checkbox"/>	Not anticipated
• Social conflicts between construction workers from other areas and community workers?	<input checked="" type="checkbox"/>	<input type="checkbox"/>	Minor and temporary impact
• Noise and dust from construction activities?	<input checked="" type="checkbox"/>	<input type="checkbox"/>	Minor and temporary impact
• Increased road traffic due to interference of construction activities?	<input checked="" type="checkbox"/>	<input type="checkbox"/>	Minor and temporary impact
• Continuing soil erosion/silt runoff from construction operations?	<input checked="" type="checkbox"/>	<input type="checkbox"/>	Minor and temporary impact
• Delivery of unsafe water due to poor O&M treatment processes (especially mud accumulations in filters) and inadequate chlorination due to lack of adequate monitoring of chlorine residuals in distribution systems?	<input checked="" type="checkbox"/>	<input type="checkbox"/>	Training for operator to be provided
• Delivery of water to distribution system, which is corrosive due to inadequate attention to feeding of corrective chemicals?	<input type="checkbox"/>	<input checked="" type="checkbox"/>	Concern for corrosion of G.I. pipes caused by the chlorine content in treated water is low. EMP provides mitigation measures.
• Accidental leakage of chlorine gas?	<input type="checkbox"/>	<input checked="" type="checkbox"/>	Bleaching power is used in Nepal
• Excessive abstraction of water affecting downstream water users?	<input type="checkbox"/>	<input checked="" type="checkbox"/>	Not applicable

SCREENING QUESTIONS	Yes	No	REMARKS
• Competing uses of water?	<input type="checkbox"/>	<input checked="" type="checkbox"/>	Not applicable
• Increased sewage flow due to increased water supply	<input checked="" type="checkbox"/>	<input type="checkbox"/>	Frequency of septage pumping to be increased; regular testing of ground water for microbiological pollution
• Increased volume of sullage (wastewater from cooking and washing) and sludge from wastewater treatment plant	<input checked="" type="checkbox"/>	<input type="checkbox"/>	Can be mitigated and improved
• Large population influx during project construction and operation that causes increased burden on social infrastructure and services (such as water supply and sanitation systems)?	<input type="checkbox"/>	<input checked="" type="checkbox"/>	Its small project, so limited number of worker will increase, and can be managed
• Social conflicts if workers from other regions or countries are hired?	<input type="checkbox"/>	<input checked="" type="checkbox"/>	Priority in employment will be given to local residents.
• Risks to community health and safety due to the transport, storage, and use and/or disposal of materials such as explosives, fuel and other chemicals during operation and construction?	<input type="checkbox"/>	<input checked="" type="checkbox"/>	Minor and temporary impact
• Community safety risks due to both accidental and natural hazards, especially where the structural elements or components of the project are accessible to members of the affected community or where their failure could result in injury to the community throughout project construction, operation and decommissioning?	<input type="checkbox"/>	<input checked="" type="checkbox"/>	Minor and temporary impact
Sanitation			
C. Potential environmental impacts			
Will the project cause...			
• Impairment of historical/cultural monuments/areas and loss/damage to these sites?	<input type="checkbox"/>	<input checked="" type="checkbox"/>	No such areas near the subproject sites.
• Interference with other utilities and blocking of access to buildings; nuisance to neighboring areas due to noise, smell, and influx of insects, rodents, etc.?	<input type="checkbox"/>	<input checked="" type="checkbox"/>	Minor and temporary impact
• Dislocation or involuntary resettlement of people?	<input type="checkbox"/>	<input checked="" type="checkbox"/>	Not applicable
• Disproportionate impacts on the poor, women and children, indigenous peoples or other vulnerable groups?	<input type="checkbox"/>	<input checked="" type="checkbox"/>	Not applicable
• Impairment of downstream water quality due to inadequate Sewage treatment or release of untreated sewage?	<input type="checkbox"/>	<input checked="" type="checkbox"/>	Toilets will be connected to septic tanks that will be designed to achieve maximum retention.
• Overflows and flooding of neighboring properties with raw sewage?	<input type="checkbox"/>	<input checked="" type="checkbox"/>	Not applicable
• Environmental pollution due to inadequate sludge disposal or industrial waste discharges illegally disposed in sewers?	<input type="checkbox"/>	<input checked="" type="checkbox"/>	Minor and temporary impact
• Noise and vibration due to blasting and other civil works?	<input checked="" type="checkbox"/>	<input type="checkbox"/>	Minor and temporary impact
• Risks and vulnerabilities related to occupational health and safety due to physical, chemical, and biological hazards during project construction and operation?	<input type="checkbox"/>	<input checked="" type="checkbox"/>	Minor and temporary impact
• Discharge of hazardous materials into sewers, resulting in damage to sewer system and danger to workers?	<input type="checkbox"/>	<input checked="" type="checkbox"/>	Minor and temporary impact
• Inadequate buffer zone around pumping and treatment plants to alleviate noise and other possible	<input type="checkbox"/>	<input checked="" type="checkbox"/>	Minor and temporary impact

SCREENING QUESTIONS	Yes	No	REMARKS
nuisances, and protect facilities?			
• Road blocking and temporary flooding due to land excavation during the rainy season?	<input checked="" type="checkbox"/>	<input type="checkbox"/>	Not applicable as construction work will be done during off rainy seasons
• Noise and dust from construction activities?	<input checked="" type="checkbox"/>	<input type="checkbox"/>	Minor and temporary impact
• Traffic disturbances due to construction material transport and wastes?	<input checked="" type="checkbox"/>	<input type="checkbox"/>	Minor and temporary impact
• Temporary silt runoff due to construction?	<input checked="" type="checkbox"/>	<input type="checkbox"/>	Not applicable
• Hazards to public health due to overflow flooding, and groundwater pollution due to failure of sewerage system?	<input type="checkbox"/>	<input checked="" type="checkbox"/>	Minor and temporary impact
• Deterioration of water quality due to inadequate sludge disposal or direct discharge of untreated sewage water?	<input type="checkbox"/>	<input checked="" type="checkbox"/>	Not applicable
• Contamination of surface and ground waters due to sludge disposal on land?	<input type="checkbox"/>	<input checked="" type="checkbox"/>	Not applicable
• Health and safety hazards to workers from toxic gases and hazardous materials which may be contained in confined areas, sewage flow and exposure to pathogens in untreated sewage and unsterilized sludge?	<input type="checkbox"/>	<input checked="" type="checkbox"/>	Not applicable
• Large population increase during project construction and operation that causes increased burden on social infrastructure (such as sanitation system)?	<input type="checkbox"/>	<input checked="" type="checkbox"/>	Not applicable
• Social conflicts between construction workers from other areas and community workers?	<input type="checkbox"/>	<input checked="" type="checkbox"/>	Priority in employment will be given to local residents.
• Risks to community health and safety due to the transport, storage, and use and/or disposal of materials such as explosives, fuel and other chemicals during construction and operation?	<input type="checkbox"/>	<input checked="" type="checkbox"/>	Not applicable.
• Community safety risks due to both accidental and natural hazards, especially where the structural elements or components of the project are accessible to members of the affected community or where their failure could result in injury to the community throughout project construction, operation and decommissioning?	<input type="checkbox"/>	<input checked="" type="checkbox"/>	Minor and temporary impact

English Translation of Minute of Meeting - Phase II

Ghorahi Small Town Water Supply Sanitation and User's Committee organized a public hearing workshop on 2072/6/7. Participation were made from all concerned stakeholders. After discussion in the public hearing it was observed that there will be no negative impacts on the environment, no necessity of land acquisition and no need of resettlement while implementing the proposed "Enhance Functionality" in Small Town Water Supply and Sanitation Sector Project. As such it was decided to inform this conclusion to the concerned authorities.

Phase 1

अस मिति २०७९ साल असार १२ गते बुधवारका दिन मल सौराष्ट्रि
 उपमहानगरपालिकाको तर्फा सभ-सम्मेलनको संख्याका अनुसार भी देवी बहादुर
 डि.ले.पू.को उपलब्धिमार्फत नगर विकास कोष का प्रतिनिधी एक समेतको
 उपलब्धिमार्फत छलफल एवं एक आपसमा अनुभव, सुझाव समझौताका को वीरमा
 छलफल गरीयो ।

उपलब्धि

— x —

सुधराम भी देवी बहादुर डि.ले. अध्यक्ष चौ.का.पा. उपमहानगर-का.पा.

- | | | | | |
|---------------|-------------------------|----------------------|-------------|---|
| <u>सुधराम</u> | भी गोविन्द प्रसाद शर्मा | सचिव - | " | " |
| <u>पुष्प</u> | भी पशु नारायण शर्मा | कोषाध्यक्ष | " | " |
| <u>मोहन</u> | भी मोहनी देवी शर्मा | सदस्य | " | " |
| <u>श्री</u> | भी गिरजा पौडेल | " | " | " |
| <u>श्री</u> | भी सरदा थापा | " | " | " |
| <u>गिरिजा</u> | भी देवकुमार पौडेल | नगर विकास कोष सचिवको | ITCC / SILT | |
| <u>श्री</u> | भी सुवास आचार्य | " | " | " |

निर्णय - मल संख्याको मिति देखि नति प्राप्त सम्मको उपलब्धिमा छलफल
 एवं मल प्रकृतिको नति संख्या देखा परेका समुदाय हरू सम्बन्धित
 गर्ने को लागी आर्थिक, सामाजिक, शारीरिक, पढाइ विस्तृत अद्याप
 गर्ने सम्बन्धित गर्ने को लागी सम्बन्धित निकायलाई अनुसन्धान गर्ने
 गर्ने निर्णय गरीयो ।

सुधराम भी देवी बहादुर डि.ले. अध्यक्ष
पुष्प भी पशु नारायण शर्मा कोषाध्यक्ष
मोहन भी मोहनी देवी शर्मा सदस्य
श्री भी गिरजा पौडेल
श्री भी सरदा थापा
गिरिजा भी देवकुमार पौडेल
श्री भी सुवास आचार्य

Phase 2

आज दिने २०७२ साल आश्विन ७ गते धर धोराही खाने-पानी उपभोक्ता तथा सरसफाई संस्था धोराही, काठको आठहानमा सरसफाईका लागि साठिखीत एक भेलाको आयोजना गरियो। यो भेलामा फलफल हुँदा हालै चामु हुन लागेको खानेपानी क्षमता अतिवृद्धि आयोजना कार्यन्वयन गर्दा बालापरवामा कुनै प्रविद्धि अझ नपर्ने, अझ अघि कुरा गर्नु नपर्ने, पुर्नकारको व्यवस्था समेत गर्नु नपर्ने देखिएकोले सोहि अनुसार सतकधीत बतवै सरसफाईका लागि जानकारी गराएको हो।

उपस्थिति

क्र.सं.	नाम, धर	हेजामा	पद	हस्ताक्षर
१	बेनी बहादुर डी. खी.	बि.सि.ड.व.स संस्था - धर	अध्यक्ष	
२	बहादुर योगी	बि.सि.ड. व.स संस्था - धर	उपअध्यक्ष	
३	जिपिउ सुब्बा शर्मा	" "	सचिव	
४	बहादुर सुब्बा शर्मा	" "	कोषाध्यक्ष	
५	दिपक कुमार श्रेष्ठ	सि.सं.सं. ३० रा. संस्था - धर	सदस्य	
६	शारदा बापा	सि.सं.सं. ३० रा. संस्था - धर	सदस्य	
७	लक्ष्मी पौडेल	सि.सं.सं. ३० रा. संस्था - धर	सदस्य	
८	रुद्रमान (९६ ना)	काठमाडौं (संस्था)		
९	हरि सुब्बा शर्मा	ITECO Nepal	Team leader	
१०	जगन्नाथ शर्मा	साविक नम्बर १३ डेडा	Div. chief	
११	दामोदर कुम्विकारी	सुब्बा शर्मा (संस्था)	सचिव	
१२	बमेश्वर सुब्बा शर्मा	सुब्बा शर्मा (संस्था)	उपअध्यक्ष	
१३	पायदव गौतम	धोराही (संस्था)	उपअध्यक्ष	
१४	मोहन सुब्बा शर्मा	" "	सदस्य	
१५	गुरु सुब्बा शर्मा	" "	उपअध्यक्ष	
१६	हेमराज वि. खी.	सुब्बा शर्मा (संस्था)		
१७	रोष सुब्बा शर्मा	सि.सं.सं. ३० रा. संस्था - धर	सदस्य	
१८	जानकी कु. खी.	शिव बहादुर रोड ११	उपअध्यक्ष	
१९	दिना डी. खी.	जानकी रोड ११	उपअध्यक्ष	
२०	कुल सुब्बा शर्मा	जानकी रोड ११	सचिव	

क्र. सं.	नाम, धर	डेजाना	पद	हस्ताक्षर
२१	प्रियवत शापा	घोरा नं पो. १०	उपमोक्षा	Prinsingh
२२	वसन्ताशर्मा	घो. नं पो. ११	सहायक	Prinsingh
२३	शाहबाबा	ववालेवाणी	सहायक	बाबु
२४	गणेश गुलाब	घोराही ११	सहायक	Prinsingh
२५	वसन्त क	घोराही ११	सहायक	Prinsingh
२६	विष्णु शर्मा	घोराही २ गुलाब	उपमोक्षा	Prinsingh
२७	विष्णु शर्मा	घोराही २ गुलाब	उपमोक्षा	Prinsingh
२८	सुरेश थापा	घोराही - २ गुलाब	सहायक	Prinsingh
२९	देवी पारसेल	घोराही ११	सहायक	Prinsingh
३०	गुणक शर्मा	घोराही ११	सहायक	Prinsingh
३१	विष्णु शर्मा	घोराही - ४. ११	सहायक	Prinsingh
३२	विष्णु शर्मा	घोराही ११	उपमोक्षा	Prinsingh
३३	विष्णु शर्मा	घोराही ११	उपमोक्षा	Prinsingh
३४	विष्णु शर्मा	घोराही ११	उपमोक्षा	Prinsingh
३५	विष्णु शर्मा	घोराही ११	उपमोक्षा	Prinsingh
३६	सुशीला आचार्य (विधवा)	घोराही - ११	सहायक	Prinsingh
३७	कृष्णा देवी शर्मा	घोराही - २ गुलाब	उपमोक्षा	Prinsingh
३८	गणेश शर्मा	घोराही ११	उपमोक्षा	Prinsingh
३९	मदन कुमार चौधरी	घोराही - २	उपमोक्षा	Prinsingh
४०	दाशरथ शर्मा	घोराही २ गुलाब	उपमोक्षा	Prinsingh
४१	विशाव दामोदर शर्मा	घोराही २ गुलाब	उपमोक्षा	Prinsingh
४२	विष्णु शर्मा	घोराही २ गुलाब	उपमोक्षा	Prinsingh
४३	लोकराज आचार्य	घोराही २ गुलाब	उपमोक्षा	Prinsingh
४४	विष्णु शर्मा	घोराही २ गुलाब	उपमोक्षा	Prinsingh
४५	जानकी आचार्य	घोराही २ गुलाब	उपमोक्षा	Prinsingh
४६	मनो आचार्य	घोराही २ गुलाब	उपमोक्षा	Prinsingh
४७	जानकी आचार्य	घोराही २ गुलाब	उपमोक्षा	Prinsingh
४८	अर्चना वली	जानकी आचार्य	उपमोक्षा	अर्चना

क्र.सं.	नाम धर	ठेगाना	पद	हस्ताक्षर
४३	मै गजसाय खर	वाँडम ११	उपभाषक	गजसाय
४४	डा. वि. शिव कुमार खर	धोराही-२ सरसती रोड	उपभाषक	खर
४५	दुर्गा के. सी.	" "	"	दुर्गा
४६	कुलवी राज ज्योतिष	" पाकुना "	"	कुलवी
४७	लाल व सुनार	" "	"	लाल
४८	दो. न. पा. १०	धोराही		दो. न. पा.
४९	व. न. पा. १०	धोराही		व. न. पा.
५०	उमाकान्त अकारी	वो. न. पा. १०	उपभाषक	उमाकान्त
५१	राम दुर्गा	धोराही ११	उपभाषक	राम
५२	अशोक अशोक	धोराही ११	सहायक	अशोक
५३	भरत शिखर	नेकपा ग्रामले प्रतिनिध	सहायक	भरत
५४	रवि चंद्र राणा	श. उ. प. ११	सचिव	रवि
५५	नारायण प्र. भांडारी	संजोगका प्रा. ११	उपभाषक	नारायण
५६	लिलाधा शर्मा	गण्डे ३ प्र. भा. ११		लिलाधा
५७	शालिकुमार पुरी	गण्डे ३ प्र. भा. १०		शालिकुमार
५८	सुधा अ. शर्मा	धोराही-२ प. भा. ११		सुधा
५९	वि. न. अ. शर्मा	धोराही	११	वि. न. अ.
६०	दीर्घा शर्मा	धोराही ११	१५	दीर्घा
६१	गोहरी के. सी.	" "	१५	गोहरी
६२	दीर्घा पट्टा	" "	"	दीर्घा
६३	जतिना	" "	"	जतिना
६४	पुष्पा शर्मा	" "	पुष्पा	पुष्पा
६५	मीरा शर्मा	धोराही ११	सहायक	मीरा
६६	कमला अशोक (भा. भा.)	धोराही ११ प. भा. ११	सहायक	कमला
६७	भवानी जीव	धोराही - १०	अभिलेख	भवानी
६८	विमला शर्मा	धोराही ११	अभिलेख	विमला
६९	कुलवी शर्मा	" " ११	अभिलेख	कुलवी
७०	अशोक शर्मा	" " ११	सचिव	अशोक
७१	विमला शर्मा	" " " "	सहायक	विमला
७२	मंजरी शर्मा	धोराही ११	उपभाषक	मंजरी

क्र.सं.	नाम धर	वैतना	पद	हस्ता
८५	जमल शीख	१९१ १०	इपमोकर	अमर
८६	शाबाना अजायब	११	इपमोकर	अमर
८७	वेद प्रसाद खेर	०९	इपमोकर	अमर
८८	सुख क. सुकेशी	१०	इपमोकर	अमर
८९	सुख अजायब	११	इपमोकर	अमर
९०	केदार शर्मा	६ मिलि (मूल) केवल	इपमोकर	अमर
९१	केदार अजायब	६ मिलि (मूल) केवल	इपमोकर	अमर
९२	जामनाथ ड. देवकोटा	धोरेवाही - २ गुलरीया	इपमोकर	अमर

(Handwritten signature)

अमर



Project Photographs

Photos on Public Gathering Meeting on Environmental and Social Issues

GHORAH



Photo No. 1



Photo No. 2



Photo No. 3



Photo No. 4



Photo No. 5



Photo No. 6