

DETAILED TECHNICAL DESCRIPTION

A. Transmission Grid

1. Six grid substations are included in the project scope of work:
 - (i) two 220/132 kilovolt (kV) gas insulated substations: Laphsiphedi and Barhabise; and
 - (ii) four new 132 kV gas insulated substations: Changunarayan, Chapagaun, Mulpani and Phutung.

2. Two of the above substations are necessary to facilitate the completion of the Tamakoshi–Kathmandu 220/400 kV Transmission Line Project which will then provide a vital power supply to Kathmandu from the upcoming generating power stations being constructed in the Khimti (Tamakoshi) area. The Tamakoshi–Kathmandu project, due for completion in 2019, comprises 95 km double circuit 400 kV transmission line (initially operated at 220 kV) interconnecting New Khimti to Barhabise and then Lapsiphedi substations (the design of both of these will also provide for future 400 kV connection). From Lapsiphedi, approximately 10 km double circuit 132 kV transmission line will then connect to Changunarayan 132 kV substation.

3. The single line diagram (SLD) in Figure 1 shows the Khimti–Kathmandu 220/400 kV transmission line and illustrates how Barhabise, Laphsiphedi and Changunarayan grid substations are interconnected in order to enable transmission supply at 132 kV and eliminate the ongoing shortage of energy in Kathmandu Valley.

Figure 1: Single Line Diagram of Barhabise, Lapsiphedi and Changunarayan Substations

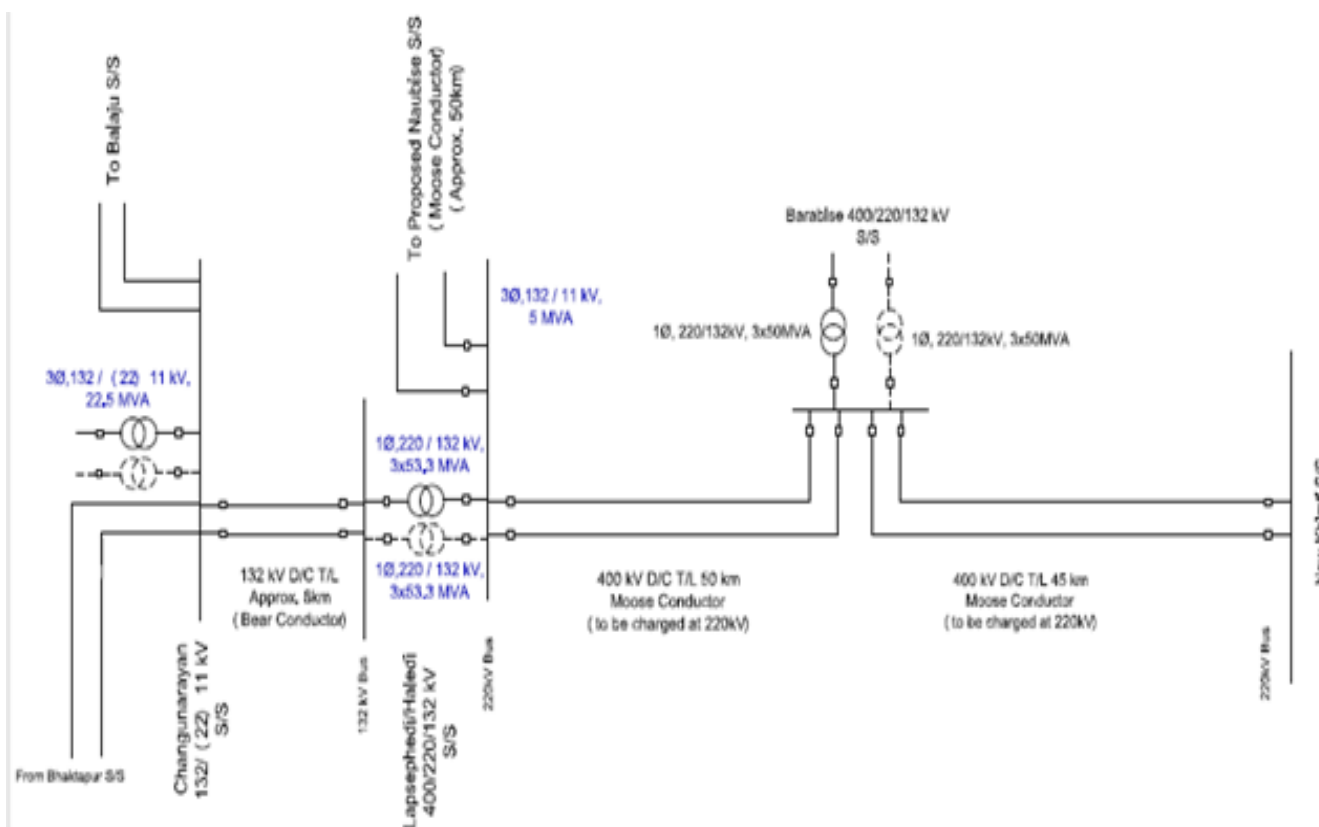

4. The locations of all six substations included in the program scope of work are shown in Figure 2 and a brief description of each follows.

Figure 2: Locations of Project Substations

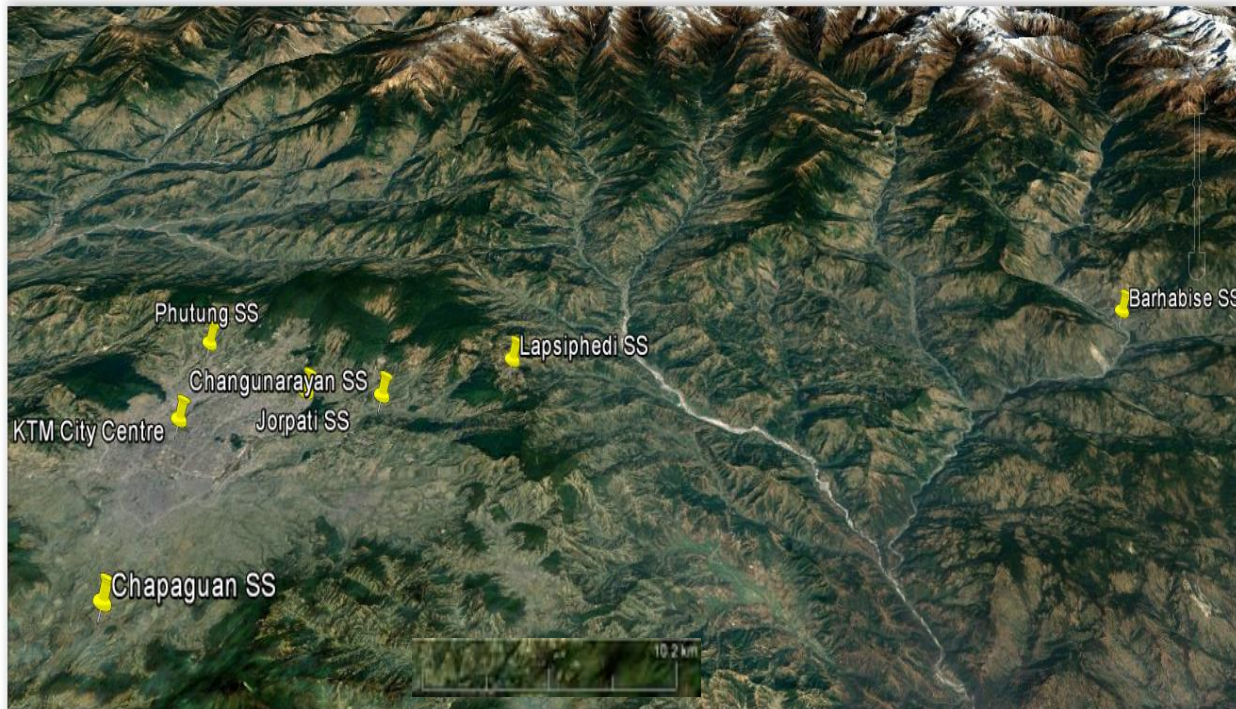

1. Bahrabise 220/132/11 kV substation

5. The substation scope includes 220/132 kV, 3 x 53.3 MVA single-phase transformer with provision for a future 220/132 kV, 132 bays for 3 x 53.3 MVA transformer; 2 bus bar and indoor switchgear module, bus coupler module, line feeder modules and 132/11 kV, 5 MVA transformer complete with switchgears for local supply. Substation will be designed for future 400 kV expansion.

2. Lapsipedi 220/132/11 kV substation

6. Located 18.8 km to the east of Kathmandu City (GPS: 27°44'42.24"N, 85°30'16.69"E). The substation scope is identical to Barhabise 220/132/11 kV substation as above.

3. Changunarayan 132/11 kV substation

7. Located 11.5 km to the east of Kathmandu City (GPS: 27°43'26.08"N, 85°25'49.67"E). The substation scope includes one 132/11 kV 45 MVA three-phase transformer with provision for a future 132/11 kV 45 MVA three-phase transformer; twelve modules of 145 kV SF₆ GIS indoor switchgear [2 busbar modules, 1 bus-coupler module, 2 (includes 1 future) transformer modules, 7 (includes 1 future) line feeder modules]; thirteen panels of 11 kV indoor VCB (vacuum circuit breaker) switchgear [1 bus-section 2,000 A panel, 2 (includes 1 future) transformer 2,000 A panels, 8 line feeder 1,250 A panels, 2 local service transformer panels].

4. Chapagaun 132/11 kV substation

8. Located 11.4 km south of Kathmandu City in Kathmandu Valley (GPS: 27°36'28.52"N, 85°19'22.98"E). The substation scope includes two 132/11 kV 45 MVA three-phase transformers,

with provision for two additional 45 MVA transformers in the future; nine sets of 145 kV SF₆ GIS indoor switchgear (2 busbar modules, 1 bus-coupler module, 2 transformer modules, 4 line feeder bays); eleven sets of 11 kV indoor VCB switchgear (1 bus-section 2,000 A panel, 2 transformer 2,000 A panels, 8 line feeder 1,250 A panels). The SLD which will be similar to the one shown in Figure 3.

Figure 3: SLD of Chapagaun 132 kV Substation

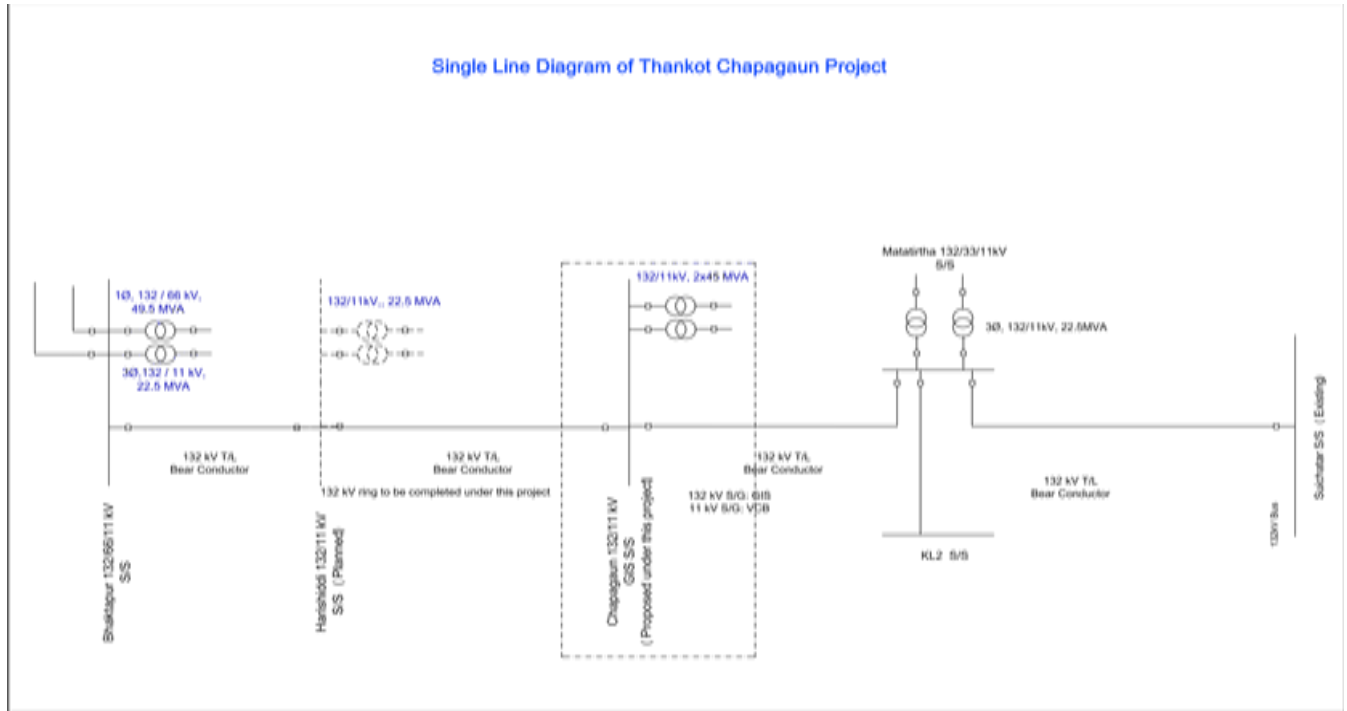

5. Mulpani 132/11 kV substation

9. Located 6.9 km east of Kathmandu City in Kathmandu Valley (GPS: 27°43'39.58"N, 85°23'5.68"E). The substation scope is identical to Chapagaun 132 kV substation as above. It was also referred to as Jorpati substation before. The SLD is shown in Figure 4.

6. Phutung 132/11 kV substation

10. Located 6.0 km north of Kathmandu City in Kathmandu Valley, was earlier referred to as Goldhunga substation (GPS: 27°45'52.34"N, 85°18'50.76"E). The substation scope is identical to Chapagaun 132 kV substation as above. The SLD is shown in Figure 4.

Figure 4: SLD of Mulpani and Phutung 132 kV Substations

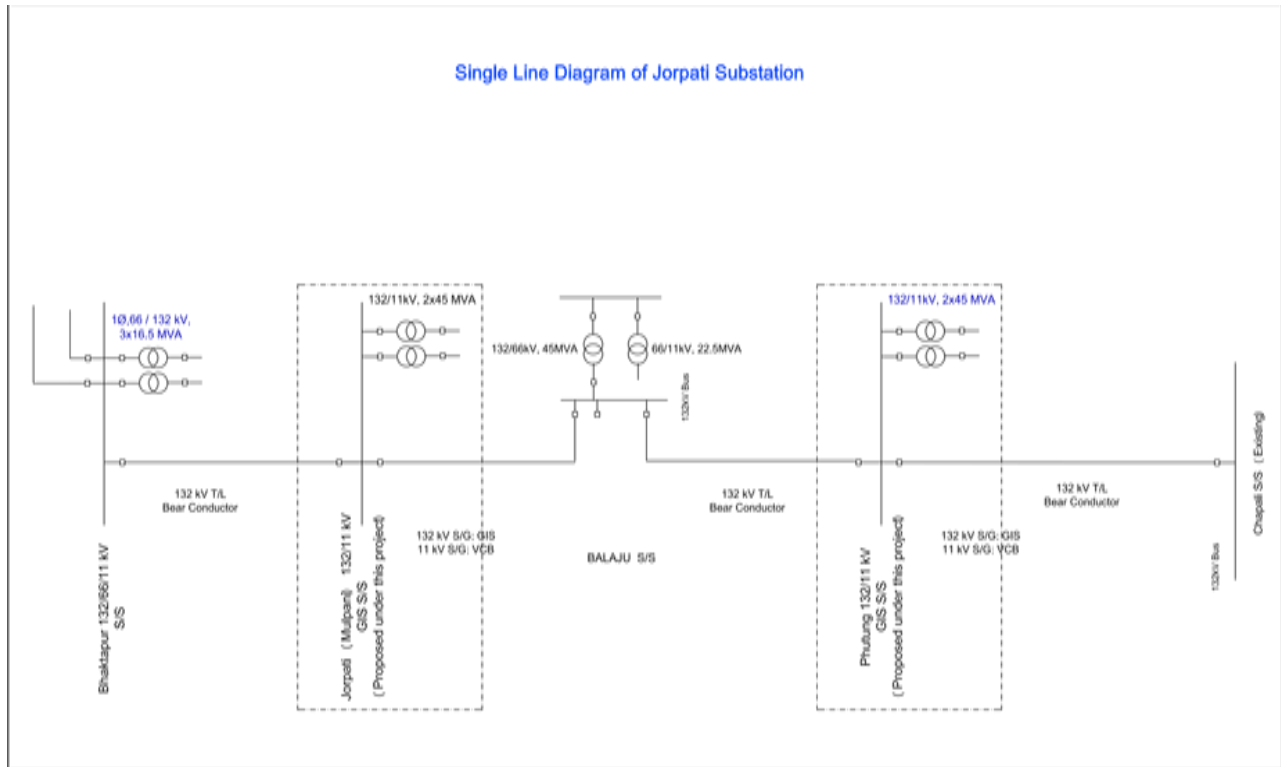

11. The above substations are vital to the provision of a reliable and secure supply of power to Kathmandu Valley. They will allow the medium voltage network to be supplied at strategic locations, particularly during planned or non-planned outages, when the MV supply can be maintained from adjacent grid substations. Barhabise and Lapsiphedi 220/132 kV substations will have provision to be upgraded to 400 kV at a future date to coincide with the re-energisation of the Khimti (Tamakoshi) - Kathmandu transmission to 400 kV. At that future point, additional capacity can be provided to Kathmandu.

B. Distribution Network

12. The distribution programme scope of work provides for the rehabilitation of low voltage and medium voltage networks in Ratnapark distribution center and, depending on availability of funds, Maharajanj DC. The approximate quantities of medium voltage and low voltage key items for the two distribution centers are shown in Table 1.

Table 1: Key Medium Voltage and Low Voltage Quantities

N ^o	Item	Unit	Quantity Ratnapark DC	Quantity Maharajganj DC
1.	O/H 11 kV lines	circuit-km		
1a.	11 kV ABC Cable, (3x150 +1x50) mm ² on 11 m PSC poles with accessories		25	25
2.	U/G 11 kV cable circuits	circuit-km		
2a.	12 kV UG, Aluminium, 400 mm ² XLPE Cable complete with accessories		40	40
2b.	12 kV UG, Aluminium, 300 mm ² XLPE Cable complete with accessories		135	135
3.	11 kV switchgear	N ^o		
3a.	12 kV RMU including installation		50	30
3b.	12 kV pole top switches		15	15
4.	O/H (ABC) LV lines	circuit-km		
4a.	400 V ABC Cable, (3x120 +1x 95+1x50) mm ² on 9 m PSC poles with accessories		200	50
4b.	400 V ABC Cable, (4x95 +1x50) mm ² on 9 m PSC poles with accessories		300	50
5.	U/G LV cable circuits	circuit-km		
5a.	1.1 kV UG, Aluminium, 500 mm ² XLPE LV cable complete with accessories		50	50
5b.	1.1 kV UG, Aluminium, 400 mm ² XLPE LV cable complete with accessories		500	100
5c.	1.1 kV UG, Aluminium, 300 mm ² XLPE LV cable complete with accessories		250	150
6	MV customer connections (excluding meters)	N ^o		
6a.	12 kV Metering Units including accessories (CT and VT)		500	400
7a.	LV service connections (excluding meters)	N ^o		
7b.	Service Cables, Meter box including accessories		50,000	40,000
8.	Revenue Meters	N ^o		
8a.	Three-phase smart energy meters		1,500	1,500
8b.	Single-phase smart energy meters		50,000	40,000
9.	Other			
9a.	LV distribution box for service connections	N ^o	2,000	2,000
9b.	9 m steel tubular poles for service lines	N ^o	500	400

CT = current transformer, DC = distribution centre, LV = low voltage, MV = medium voltage, RMU = ring main unit (switchgear), PSC = pre-stressed concrete (poles), UG = underground, VT = voltage transformer, XLPE = cross-linked polyethylene (cable).

Source: Nepal Electricity Authority estimates.

13. The existing 11 kV network for Ratnapark Distribution Center is shown in Figure 5. It is supplied from four area substations and currently has 48,986 customers and annual sales of 207 GWh (111 GWh or 54 % being domestic) as of 15 July 2016.

Figure 5: Ratnapark Distribution Center 11 kV Network Diagram

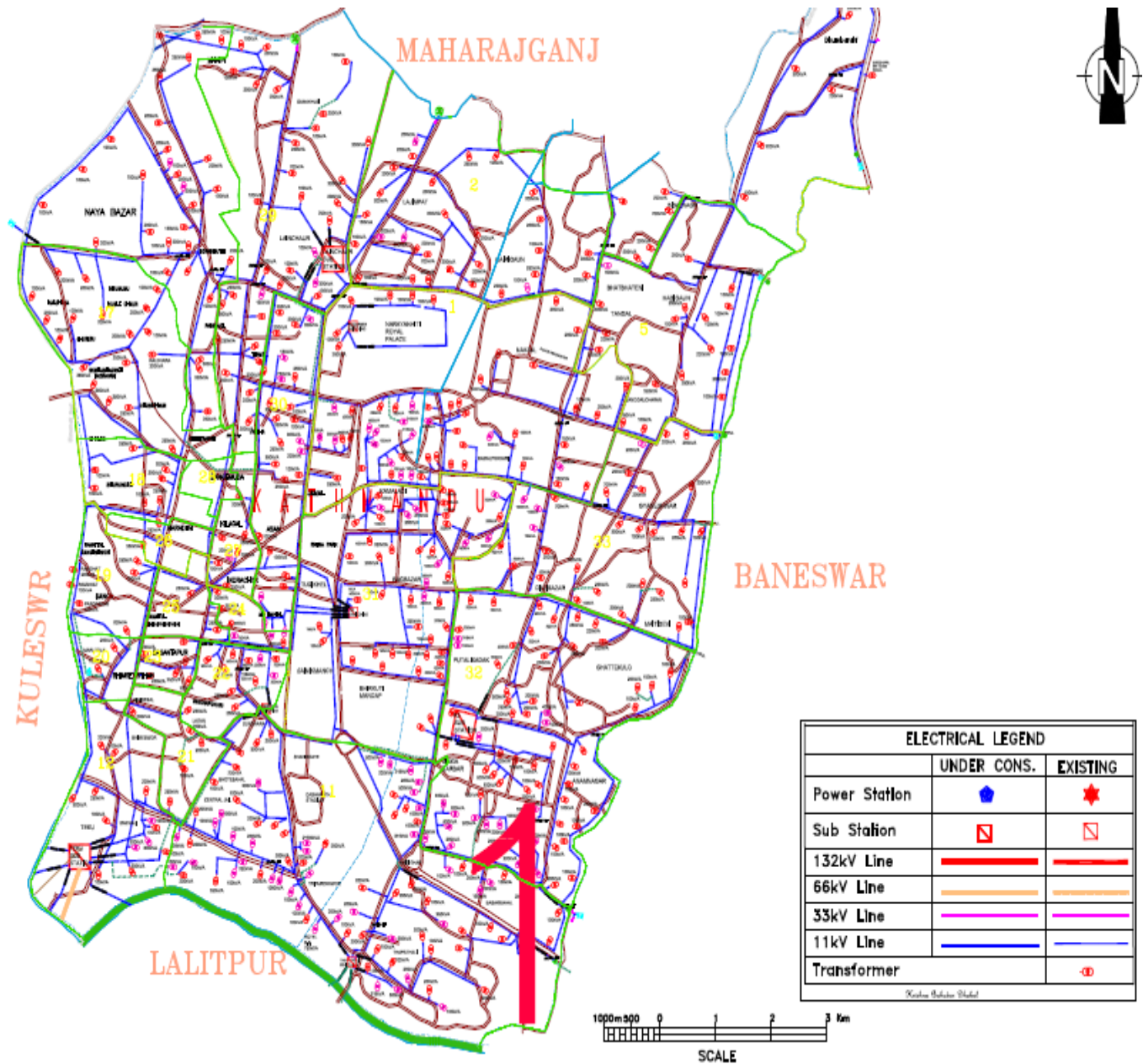

14. The existing 11 kV network for Maharajanj Distribution Center is shown in Figure 6. As of 15 July 2016, it is supplied from three substations and services 37,857 customers with annual sales of 110 GWh (71 GWh or 65 % being domestic).

Figure 6: Maharajganj Distribution Center 11 kV Network Diagram

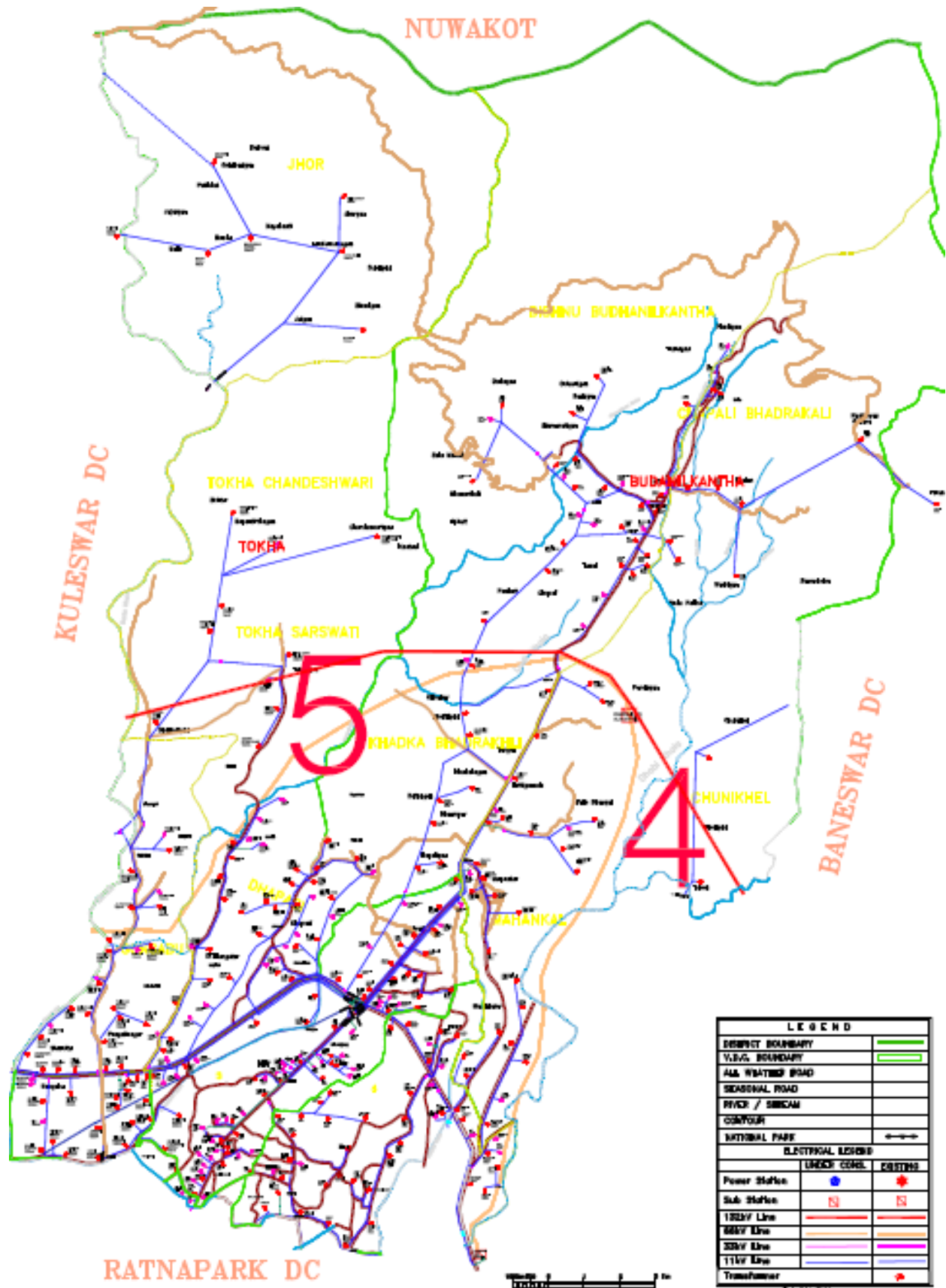

15. The majority of the new construction will be underground, since overhead distribution is impractical in the densely populated areas where the access roads are very narrow. In Ratnapark Distribution Center, 87.5% of the medium voltage and 62% of the low voltage will be underground; in Maharajganj also 87.5% medium voltage and 75% low voltage underground. Special consideration will be given during construction to minimize any disruptions in access by the local population; this includes for example the overnight installation of cable ducts so that normal traffic flows can resume during the day. Medium voltage underground cables will be three-core cross-linked polyethylene (XLPE) insulated; LV cables will be four-core XLPE insulated.

16. In keeping with modern international best-practice, all new medium voltage and low voltage overhead construction will utilize three-phase ABC (aerial bundled conductor) because of the inherent safety and technical advantages over the open wire system. The ABC is more economical than the older open wire system and minimizes losses (both technical and non-technical) and improves voltage quality. It is not susceptible to outages due to tree interference, especially in poor weather conditions.

17. Single-phase and three-phase smart meters will be installed in customer meter boxes in keeping with modern international practice. The key advantage of smart metering is the ability to monitor and control the meter remotely (including programming the meter to be either pre-pay or post-pay; recording of customer usage data; ability to detect loss of power and tampering of connections). This will contribute significantly to the reduction in non-technical losses. Annex 1 outlines a Smart Metering Strategy for Nepal.

NEPAL SMART METERING STRATEGY

1. The benefits of Nepal's adoption of smart meter technologies will mirror what can be seen in a number of countries and will deliver benefits to the customers and the Nepal Electricity Authority (NEA). In the initial stages of the rollout program, immediate benefits such as reduced meter reading costs, access to time of use based tariffs and the cut back in non-technical losses will be realized. The benefits for NEA will be less immediate but eventually include:

- (i) improved network visibility and hence reduced or deferred network reinforcement costs;
- (ii) improved management of power outages;
- (iii) improved connection processes;
- (iv) reduced costs for micro-generation customers;
- (v) access to the benefits offered by demand side response;
- (vi) losses reduction; and
- (vii) improved customer service across a range of routine activities.

2. While the introduction of smart meters will bring immediate benefits to customers, their full potential in relation to network-related benefits will only be realized as customers start to adopt behavioral changes in power consumption or integrate decentralized installed generation. In addition, in the early years of the smart meter rollout program the penetration levels for smart meters will not initially facilitate a number of the benefits associated with network management.

How will smart meters improve network visibility?

3. Smart meters will, for the first time, allow NEA to monitor how much power their customers are using or producing in real time. This will allow NEA to not only influence their usage but to operate their network to be more responsive to their needs. The more responsive NEA can make their network, the more efficiently it operates and that helps them to keep customers bills lower.

4. For many years, utilities have had monitoring systems covering their high voltage networks enabling these systems to become steadily more efficient. However, presently they have virtually no visibility of their customers' needs on the medium voltage and low voltage network. The improved visibility provided through smart meter data will revolutionize network management allowing NEA to monitor demand across their entire network for the first time ever. This will help NEA to better ensure capacity is available for their customers to use when they need it and help them to ensure they only spend money increasing the capability of the network when necessary.

5. Customers are increasingly adopting micro distributed generation technologies such as roof top photovoltaic; this generation technology can have huge benefits for both customers and the country. However, they also introduce a number of challenges for NEA. The rapid adoption of micro distributed generation by tens of thousands of customers is likely to result in localized reverse power flows whenever generation output exceeds the demand. This can cause voltages to rise and there is an urgent need to monitor voltages to ensure statutory limits are not exceeded. At the moment, there is no technology deployed to monitor rooftop solar output¹ and smart meters will allow NEA access to this information at very low cost. Ultimately these savings can be passed on to NEA's customers.

6. Smart meters will provide greatly improved visibility of voltage profiles along low voltage networks enabling better control of voltage and hence more efficient connection costs for all distributed generation equipment such as photovoltaic or heat pumps. International studies clearly

¹ Most of the rooftop systems in the Kathmandu Valley are not grid-connected, but eventually these micro distributed generation assets should be connected.

indicate that network visibility improvements enable lower connection costs using connect and manage technologies.

How will smart meters improve management of power outages?

7. Smart meters offer a number of important service benefits for customers experiencing power outages. Currently most customer interruptions are not detected automatically by the network operations and control systems, hence detecting interruptions which arise due to low voltage network faults is dependent on customer calls to distribution centres. Smart meters offer significant functionality for the automatic notification of loss of supply for individual customers and NEA can incorporate these functions within their trouble-shooting management systems.

8. This will enable more rapid restoration of supplies particularly during unpredictable events, e.g. natural disasters. Smart meters which are in compliance with global standards will be sufficient to allow outage detection on the vast majority of low voltage network events. The primary benefit for customers of early outage detection manifests in the form of a slightly earlier mobilization of NEA's operational response and hence earlier supply restoration. Global analysis of call patterns versus time of interruption indicates that this will result in an average 8 minute earlier detection and mobilization.

9. There will be a secondary benefit in terms of fault unit cost performance which arises through the more accurate diagnosis of the network section affected by open circuit low voltage cable faults. In the NEA context and the current situation in Nepal the benefits can be estimated at approximately \$0.5 million per annum arising from a significant faster localization of such faults.

10. Smart meters offer additional benefits for customers during natural disaster events, as they enable more accurate diagnosis of low voltage network faults and hence better prioritization of available repair resources and earlier supply restoration for some customers. These do not result in any reduction in repair costs as the same numbers of faults need to be repaired. However, more customers will benefit from earlier supply restoration.

11. It can be anticipated that smart meters will be of assistance in diagnosing low voltage network faults underlying high voltage faults post high voltage network repairs or supply shortages. Again, this will allow most customers to have services restored earlier leading to improved service at the macro level; however, similar to that noted above, there are no net reductions in repair costs. Use of last gasp functionality does ensure this scenario as penetration levels increase and communications and information technology systems bed in. It is not possible to fully evaluate the financial benefits of this functionality until tested; however, the benefits for customers are very apparent and the NEA should be committed to maximizing all possible service benefits.

12. While the so called 'first breath' and associated 'pinging' functionality has an important role to play in positive confirmation of supply restoration, NEA's customers and particularly the vulnerable customers, according to global surveys, consistently prefer a "warm voice" contact post supply restoration so as to enable them to understand the cause of the interruption and the likelihood of a repeat interruption. As such, simultaneous introduction of consumer engagement program is proposed.

How will smart meters improve our connection processes?

13. Improved network visibility as described above will also enable NEA to process connection applications more quickly and provide customers with greater certainty of efficient costs. Customers will benefit from a reduction in associated quotation and installation times. All direct

cost benefits arising from smart meter data enabling more effective designs potentially can accrue to customers in terms of reduced connection costs.

How will smart meters facilitate demand side response?

14. A significant potential benefit from smart meters arises from their potential to change customer demand patterns; either via a time-of-use tariff signal or by use of the load switch.

15. An innovation strategy will require the NEA to continue to explore new ways of engaging with customers to mitigate the effect of distributed generation on the network. The NEA can put themselves at the forefront of change and development in this area; for example, the development of new local energy market services such as consumer-to-consumer, the use of third party services such as aggregators, social landlords or communities of customers to effectively purchase distributed resource services to deliver network benefits. These new services have the potential to marginally reduce costs under normal scenarios but have much greater potential to reduce costs under higher deployed distributed generation scenarios.

16. The NEA has to work with regulatory officials on the development of suitable uncertainty mechanisms to ensure the benefits of such work are appropriately shared between customers and other stakeholders.

17. Critically, this paper is based on a number of benefit assumptions based on international experience, specifically the forecast cost of services such as demand side response, storage and other new technologies. In the event that costs or other assumptions vary, then the associated benefits may change and hence trigger the load re-opener.

How will smart meters aid loss reductions?

18. It is inevitable that as energy flows increase technical network losses will increase proportionally, however the effects of smart meters on peak energy demand may assist NEA in helping to curtail this rise. In particular, improved network visibility will allow them to progressively improve the management of feeder voltage profiles and hence improve technical losses management.

19. Experiences in particular in developing countries have shown that smart meters can dramatically reduce non-technical losses. Real time consumption data and load-profiles combined with the tamper control functionality of the meter do have an immediate effect on non-technical losses. For example, in New Delhi non-technical losses were cut down from 45% to less than 7% with a year's time after the start of the smart meter roll out.

20. The definition of an 'Intelligent Energy Network' of the 21st century is based on elements that are required 'behind' and 'beyond' the meter, as depicted in Figure A.1.

Figure A.1: Smart Metering System

