

# Draft Environmental and Social Impact Assessment

Project Number: 48330  
March 2015

## AZE: Shah Deniz Stage II Gas Field Expansion Project (Addendum - Early Infrastructure Works)

Prepared by URS Corporation Limited for Shah Deniz 2 Project

This environmental and social impact assessment is a document of the borrower. The views expressed herein do not necessarily represent those of ADB's Board of Directors, Management, or staff, and may be preliminary in nature. Your attention is directed to the "Terms of Use" section of this website.

In preparing any country program or strategy, financing any project, or by making any designation of or reference to a particular territory or geographic area in this document, the Asian Development Bank does not intend to make any judgments as to the legal or other status of any territory or area.

## **ACKNOWLEDGEMENTS**

This Environmental and Socio-Economic Impact Assessment (ESIA) for the Shah Deniz 2 Infrastructure Project was carried out by URS Corporation Limited on behalf of BP (operator) and the SD PSA Co-Venturers.

URS acknowledges the collective and individual contributions from a range of companies, academic and scientific experts in the preparation of this Environmental Statement. URS is grateful for the willing assistance of these companies and individuals and their contributions to a rigorous and comprehensive report.

### **URS acknowledges with thanks the following:**

#### **Companies**

The Social Consultancy  
WRA  
Synergetics  
KBR  
CBM Caspian

#### **Academic and Scientific Experts**

##### **Individual**

Shakir Kasumov  
Ilyas Babayev

##### **Expertise**

Botanist  
Bird Specialist

#### **Academic, Scientific and Government Institutions**

Azerbaijan Ministry of Ecology and Natural Resources  
State Oil Company of Azerbaijan Republic  
Azerbaijan Ministry of Culture and Tourism  
Baku State University National Hydrometeorological Department  
Institute of Archaeology and Ethnography  
Institute of Botany  
Institute of Geography  
Garadagh District Executive Power

Stakeholder and Socio-Economic Survey participants within the Umid, Sangachal, Masiv 3 and Azim Kend communities.

## Contents

### Executive Summary

Units and Abbreviations  
Glossary

### 1. Introduction

1.1	Introduction	1/2
	1.1.1 Shah Deniz Production Sharing Agreement	1/3
	1.1.2 Previous Terminal Development	1/3
1.2	SD2 Infrastructure Project Overview	1/4
1.3	SD2 Infrastructure Environmental and Social Impact Assessment	1/4
	1.3.1 Objectives	1/4
	1.3.2 ESIA Team and Structure	1/5

### 2. Policy, Regulatory and Administrative Framework

2.1	Introduction	2/2
2.2	Regulatory Agencies	2/2
2.3	Production Sharing Agreement	2/2
2.4	National Environmental Legislation	2/7
	2.4.1 National EIA Guidance	2/11
2.5	Regional Processes	2/12
	2.5.1 European Union	2/12
	2.5.2 Environment for Europe	2/12
2.6	International Petroleum Industry Standards and Practices	2/12
2.7	BP Requirements	2/13

### 3. Impact Assessment Methodology

3.1	Introduction	3/2
3.2	ESIA Process	3/2
	3.2.1 Screening and Scoping	3/3
	3.2.2 Project Alternatives and Base Case Design	3/3
	3.2.3 Existing Conditions	3/4
	3.2.4 Impact Significance Assessment	3/4
	3.2.5 Environmental Impacts	3/5
	3.2.6 Socio-Economic Impacts	3/8
3.3	Transboundary and Cumulative Impacts	3/9
3.4	Mitigation and Monitoring	3/10

### 4. Options Assessed

4.1	Introduction	4/2
	4.1.1 Determination of Project Scope	4/2
	4.1.2 Route Option Assessment	4/4
	4.1.3 Construction Camp and Facilities Locations	4/9
	4.1.4 Pipeline Landfall Area	4/9
	4.1.5 Drainage Management and Flood Protection	4/10

## 5. Project Description

5.1	Introduction	5/2
5.2	Development Areas and Land Acquisition	5/4
5.3	Logistics and Material Supply	5/4
5.4	Project Schedule	5/5
5.5	Project Phases	5/6
	5.5.1 Phase 1 – Set Up of Initial Site Compound	5/6
	5.5.2 Phase 2 – Establishment of the Enabling Road and Power Diversion Works	5/7
	5.5.3 Phase 3 – Site Preparation	5/8
	5.5.4 Phase 4 – Main Civils Works	5/12
	5.5.5 Phase 5 – Earthworks Profiling	5/14
	5.5.6 Phase 6 – Completion and Fit Out of Construction Camp and Construction Facilities	5/15
	5.5.7 Phase 7 – Closure of Enabling Road and at-Grade Rail Crossings	5/17
5.6	Construction Materials	5/18
5.7	Construction Plant/Vehicles/Equipment	5/19
	5.7.1 Numbers of Onsite Plant/Equipment/Vehicles	5/19
	5.7.2 Numbers of Offsite Vehicles and Routing	5/20
5.8	Emissions, Discharges and Waste	5/20
	5.8.1 SD2 Infrastructure Project Emissions	5/20
	5.8.2 SD2 Infrastructure Project Discharges	5/20
	5.8.3 SD2 Infrastructure Project Hazardous and Non Hazardous Waste	5/21
5.9	Training and Employment	5/22
5.10	Working Hours and Nighttime Working	5/22
5.11	Management of Change Process	5/22

## 6. Environmental Description

6.1	Introduction	6/3
6.2	Data Sources	6/3
6.3	Physical Environment	6/6
	6.3.1 Seismicity	6/6
	6.3.2 Climate	6/6
	6.3.3 Temperature	6/6
	6.3.4 Precipitation	6/6
	6.3.5 Wind	6/7
6.4	Terrestrial Environment	6/7
	6.4.1 Setting	6/7
	6.4.2 Hydrology	6/8
	6.4.3 Geology, Soils and Historical Pollution	6/11
	6.4.4 Groundwater and Surface Water	6/12
	6.4.5 Air Quality	6/15
	6.4.6 Noise	6/19
	6.4.7 Terrestrial Ecology	6/22
6.5	Coastal Environment	6/28
	6.5.1 Settling	6/28
	6.5.2 Coastal Habitat	6/28
	6.5.3 Coastal Birds	6/29
6.6	Archaeology and Cultural Heritage	6/31

## **7. Socio-Economic Description**

7.1	Introduction	7/2
7.2	Geographic Context	7/2
7.3	Data Sources	7/3
7.4	Socio-economic Conditions	7/4
	7.4.1 Population and Demographics	7/4
	7.4.2 Land Use and Ownership	7/6
	7.4.3 Infrastructure	7/7
	7.4.4 Education and Training	7/10
	7.4.5 Health	7/11
	7.4.6 Employment and Livelihoods	7/12
	7.4.7 Economic Activity	7/15
	7.4.8 Income and Expenditure	7/15
7.5	Community Investment	7/17
7.6	Local Content Development	7/18

## **8. Consultation and Disclosure**

8.1	Introduction	8/2
8.2	Overview of Consultation and Disclosure Process	8/2
8.3	Scoping, Initial Stakeholder Engagement and Consultation	8/3
8.4	Draft Final ESIA Report Consultation	8/6
8.5	Post ESIA Project Consultation	8/6

## **9. Environmental Impact Assessment, Mitigation and Monitoring**

9.1	Introduction	9/2
9.2	Scoping Assessment	9/2
9.3	Impacts to the Atmosphere	9/6
	9.3.1 Emissions From Onsite and Offsite Construction Plant and Vehicle	9/6
	9.3.2 Dust Due to Surface Soil Layer Removal and Spoil Movement	9/8
9.4	Impacts to the Terrestrial Environment (Noise)	9/11
	9.4.1 Construction Noise	9/11
9.5	Impacts to the Terrestrial and Coast Environment (Ecology)	9/17
	9.5.1 Impact to Ecology Due to Earthworks	9/17
9.6	Impacts to the Terrestrial Environment (Soil, Groundwater and Surface Water)	9/21
	9.6.1 Excavation Works and Ground Excavation	9/21
9.7	Impacts to the Terrestrial & Coastal Environment (Cultural Heritage)	9/23
	9.7.1 Impacts to Cultural Heritage Due to Earthworks and Piling	9/23
9.11	Summary of SD2 Infrastructure Project Residual Environmental Impacts	9/26

## **10. Socio-Economic Impact Assessment, Mitigation and Monitoring**

10.1	Introduction	10/2
10.2	Scoping Assessment	10/2
10.3	Land Access	10/4
	10.3.1 Disruption /Access Restrictions to Natural Resources and Recreation	10/4
10.4	Employment	10/7
10.5	Training and Skills Development	10/8
10.6	Procurement	10/10
10.7	Construction Vehicle Movement (off-site)	10/11
	10.7.1 Disruption and Community Safety	10/11
	10.7.2 Road Conditions	10/12
10.8	Road and Railway Closures and Traffic Works	10/13

---

10.9	De-manning	10/14
10.10	Indirect Impacts	10/15
	10.10.1 Local Economic Impacts	10/15
	10.10.2 Social Conflict	10/16
	10.10.3 Anti-Social behaviour	10/16
	10.10.4 Mitigation of Indirect Impacts	10/16
10.11	Summary of SD2 Infrastructure Project Residual Socio-Economic Impacts	10/16
<b>11.</b>	<b>Cumulative and Transboundary Impacts and Accidental Events</b>	
11.1	Introduction	11/2
11.2	Cumulative and Transboundary Impacts	11/2
11.3	Cumulative Assessment	11/2
	11.3.1 Cumulative Impact between Separate Project Impacts	11/2
	11.3.2 Cumulative Impacts With Other Projects	11/3
	11.3.3 Approach to Cumulative Assessment	11/4
	11.3.4 Assessment of Cumulative Impacts	11/5
	11.3.5 Conclusion	11/10
11.4	Accidental Events	11/10
	11.4.1 Overview	11/10
	11.4.2 Potential Accidental Events	11/10
	11.4.3 Measures to Mitigate Accidental Events	11/11
	11.4.4 Spill Response	11/15
	11.4.5 Spill Reporting	11/17
<b>12.</b>	<b>Environmental and Social Management</b>	
12.1	Introduction	12/2
12.2	Contractor Selection	12/2
12.3	Contractor's Management System	12/2
	12.3.1 Approach	12/2
	12.3.2 HSSE Management System Requirements	12/3
12.4	Waste Management	12/5
	12.4.1 Waste Management Processes and Procedures	12/5
	12.4.2 Waste Segregation and Transfer	12/5
12.5	Environmental Monitoring	12/6
<b>13.</b>	<b>Conclusions</b>	
13.1	Introduction	13/2
13.2	Environmental Impacts	13/2
13.3	Socio-Economic Impacts	13/5
13.4	Cumulative, Transboundary and Accidental Events	13/8
13.5	Environmental and Social Management	13/9
13.6	Conclusions	13/10

## List of Figures

Figure 1.1	Sangachal Terminal Location	1/2
Figure 1.2	SD2 Infrastructure Project Scope of Work	1/4
Figure 2.1	Azerbaijan Legal Hierarchy	2/2
Figure 3.1	The ESIA Process	3/2
Figure 4.1	Key Constraints	4/3
Figure 4.2	Access Road Rout Options	4/5
Figure 5.1	Overview of SD2 Infrastructure Project	5/3
Figure 5.2	Maximum Extent of Acquisition and Current Terminal Property Boundary	5/4
Figure 5.3	Import Routes to Azerbaijan	5/5
Figure 5.4	Indicative SD2 Infrastructure Project Schedule	5/5
Figure 5.5	Phase 2 - Enabling Road	5/8
Figure 5.6	Phase 3 – Site Preparation	5/9
Figure 5.7	Typical Flood Protection Berm Cross Section	5/10
Figure 5.8	Drainage Channel Works, Indicative Culvert and Pipeline Crossing Locations	5/11
Figure 5.9	Phase 5 – Earthworks Profiling	5/15
Figure 5.10	Phase 6 – North Construction Camp and South Construction Facilities Conceptual Layouts	5/16
Figure 5.11	Phase 7 – Enabling Road Closures	5/18
Figure 6.1	Terrestrial and Coastal Areas Associated with the SD2 Infrastructure Project	6/5
Figure 6.2	Annual Wind Rose (Baku Airport), 2007	6/7
Figure 6.3	Main Drainage Catchment Areas in the Vicinity of the Terminal	6/9
Figure 6.4	Location of Abandoned Exploratory Drilling Wells and Soil and Groundwater Monitoring Boreholes	6/11
Figure 6.5	Observed Spills in Wetland Vicinity, June 2011	6/14
Figure 6.6	Ambient Air Quality (2009 & 2010) and Odour Monitoring Locations (2010)	6/15
Figure 6.7	Noise Survey Locations, 2010 and 2011	6/20
Figure 6.8	Approximate Distributions of Plant Community Types (Habitats) Around the Terminal	6/23
Figure 6.9	Major Vegetation Types within SD2 Infrastructure Area (as surveyed), 2008	6/23
Figure 6.10	Bird Monitoring Locations Around the Terminal (2008, 2009 and 2010)	6/27
Figure 6.11	Important Ornithological Sites Located on the Southwest Caspian Coast	6/30
Figure 6.12	Bird Migration Routes	6/31
Figure 6.13	Archaeological Survey Finds/Cultural Heritage Sites, 2001	6/32
Figure 6.14	The SD2 Pipeline Landfall Area and the Area Undisturbed Through Quarrying	6/33
Figure 6.15	Courtyard Interior of the Caravanserai	6/34
Figure 7.1	Garadah District, the Terminal and Surrounding Communities	7/3
Figure 7.2	Land Use with Vicinity of the Terminal	7/7
Figure 7.3	BP Projects Construction Workforce, 2002 to 2007	7/14
Figure 8.1	SD2 Infrastructure Project ESIA Consultation and Disclosure Process	8/3
Figure 9.1	Modelled Increase in Short Term (24 hour) PM <sub>10</sub> Emissions At Ground Level Due to Surface Soil Layer Removal and Spoil Movement	9/10
Figure 9.2	Predicted Noise Levels (Realistic Scenario) at Sangachal (Onsite Construction Plant and Vehicles)	9/13
Figure 11.1	Location of the Planned or Under Construction Projects in the Terminal Vicinity	11/4
Figure 11.2	Potential Overlap Between Planned and Under Constructions Project and the SD2 Infrastructure Project	11/5

Figure 11.3	Main Drainage Catchment Areas in the Vicinity of Terminal Including Modifications Associated with Proposed Qizildas Cement Plant	11/8
Figure 11.4	Location of Existing Pipelines	11/12
Figure 11.5	Indicative Locations of EOP Concrete Barriers and Buried Pipeline Protection	11/13
Figure 11.6	BP's Incident Management System	11/16
Figure 11.7	Site Emergency Response Organisation	11/17
Figure 12.1	Roles and Responsibilities of the Contractor and BP	12/3

## List of Tables

Table 1.1	Onshore Scope of Works Assessed Within Previous ACG and SD ESIA	1/3
Table 1.2	SD2 Infrastructure Project ESIA Team	1/5
Table 1.3	Structure and Content of the ESIA	1/5
Table 2.1	Summary of International Conventions	2/5
Table 2.2	Summary of Regional Conventions	2/6
Table 2.3	Key National Environmental and Social Laws	2/8
Table 2.4	Summary of Guidance on the EIA Process in Azerbaijan	2/11
Table 3.1	Event Magnitude Rankings	3/5
Table 3.2	Receptor Sensitivity Rankings	3/7
Table 3.3	Impact Significance	3/7
Table 3.4	Socio Economic Impact Significance	3/9
Table 4.1	Existing Physical, Environmental and Safety Constraints	4/3
Table 4.2	Description of the Route Groups	4/4
Table 4.3	Route Option Assessment	4/6
Table 5.1	Estimated Volumes of Spoil Materials and Intended Reuse	5/12
Table 5.2	STP Discharge Standards	5/13
Table 5.3	Potentially Hazardous Material Storage Principles	5/19
Table 5.4	Estimated Number of Onsite Construction Plant and Vehicles	5/19
Table 5.5	Estimated Number of Daily Offsite SD2 Infrastructure Vehicle Movements	5/20
Table 5.6	Estimated GHG and Non GHG Emissions Associated with SD2 Infrastructure Activities	5/20
Table 5.7	Estimated Hazardous and Non Hazardous Waste Associated with SD2 Infrastructure Activities	5/21
Table 5.8	Construction Waste Streams	5/22
Table 6.1	Relevant Baseline and Monitoring Surveys Completed to Date	6/4
Table 6.2	Average Monthly Rainfall Data (Baku) 2002 to 2006	6/6
Table 6.3	SD2 Infrastructure Area Soil Sample Results, 2008	6/12
Table 6.4	TPH and Heavy Metal Results of Groundwater Samples, 2008	6/13
Table 6.5	Results of Surface Water Samples, 2006 Survey	6/13
Table 6.6	Average NO <sub>2</sub> Air Quality Concentrations, 2009 and 2010 (µg/m <sup>3</sup> )	6/16
Table 6.7	Average SO <sub>2</sub> Air Quality Concentrations, 2009 and 2010 (µg/m <sup>3</sup> )	6/17
Table 6.8	Average Benzene and VOC Concentrations, 2009 and 2010 (µg/m <sup>3</sup> )	6/17
Table 6.9	PM <sub>10</sub> Concentrations, 2009 and 2010 (µg/m <sup>3</sup> )	6/18
Table 6.10	2010 and 2011 Noise Survey Results in the Vicinity of the Terminal and Roadside Locations	6/21
Table 6.11	Breeding and Incubation Periods of the Spur-Thighed Tortoise	6/27
Table 6.12	Summary of 2001 Archaeological Survey Finds/Cultural Heritage Sites	6/31
Table 7.1	Relevant Data Sources	7/4
Table 7.2	Azerbaijan Population 1990 to 2010	7/4
Table 7.3	Number of IDPs within the Garadagh District	7/5
Table 7.4	National Age Profile, Urban and Rural, 2010	7/5



Table 7.5	District Population, Migration Increase Death and Fertility Rates, 2005-2010	7/6
Table 7.6	Bus Route Serving the communities within the Terminal Vicinity	7/8
Table 7.7	Perceived Conditions of Public Transport in the Communities within the Terminal Vicinity	7/8
Table 7.8	Source of Potable Water in the Communities within the Terminal Vicinity	7/9
Table 7.9	Perceived Reliability of the Water Network in the Communities within the Terminal Vicinity	7/9
Table 7.10	Perceived Quality of the Potable Water Supply in the Communities Within the Terminal Vicinity	7/9
Table 7.11	Perceived Condition of Drain and Sewage Infrastructure in the Communities within the Terminal Vicinity	7/10
Table 7.12	Level of Satisfaction with Existing Waste Disposal Arrangements in the Communities Within the Terminal Vicinity	7/10
Table 7.13	Type of Healthcare Infrastructure Used by Households in the Communities within the Terminal Vicinity	7/11
Table 7.14	Most Reported Health Problems in Communities Surrounding the Terminal During Four Week Period (May-Jun 2011)	7/12
Table 7.15	Employment Locations for Households Surveyed in the Communities within the Terminal Vicinity	7/13
Table 7.16	Monthly Incomes in the Communities within the Terminal Vicinity	7/16
Table 7.17	Primary Sources of Income in the Communities within the Terminal Vicinity	7/16
Table 7.18	Secondary Sources of Income in the Communities within the Terminal Vicinity	7/16
Table 7.19	Monthly Household Expenditure in the Communities within the Terminal Vicinity	7/17
Table 7.20	Source of food purchases in the Communities with the Terminal Vicinity	7/17
Table 7.21	BP/AIOC social spend 2002 to 2009	7/18
Table 7.22	Local content spend 2006 to 2010	7/18
Table 8.1	Key Issues Raised During Initial Consultation	8/6
Table 9.1	Structure of SD2 Infrastructure Project Impact Assessment	9/2
Table 9.2	“Scoped Out” SD2 Infrastructure Project Routine and Non-Routine Activities	9/3
Table 9.3	“Assessed” SD2 Infrastructure Project Routine and Non-routine Activities	9/5
Table 9.4	Event Magnitude	9/7
Table 9.5	Human Receptor Sensitivity	9/8
Table 9.6	Impact Significance	9/8
Table 9.7	Event Magnitude	9/11
Table 9.8	Impact Significance	9/11
Table 9.9	Noise Levels at Sensitive Receptors Associated with Piling Activities	9/14
Table 9.10	Worst Case Construction Noise Levels at Receptors (All Construction Activities)	9/15
Table 9.11	Event Magnitude	9/15
Table 9.12	Human Receptor Sensitivity	9/15
Table 9.13	Biological/Ecological Receptor Sensitivity	9/16
Table 9.14	Impact Significance	9/16
Table 9.15	Event Magnitude	9/19
Table 9.16	Biological/Ecological Receptor Sensitivity	9/20
Table 9.17	Impact Significance	9/21
Table 9.18	Event Magnitude	9/22
Table 9.19	Receptor Sensitivity (Soil)	9/23
Table 9.20	Receptor Sensitivity (Surface Water)	9/23
Table 9.21	Impact Significance	9/23
Table 9.22	Event Magnitude	9/25

Table 9.23	Receptor Sensitivity	9/25
Table 9.24	Impact Significance	9/26
Table 9.25	Summary of SD2 Infrastructure Project Residual Environmental Impacts	9/26
Table 10.1	“Scoped Out” SD2 Infrastructure Project Routine and Non-Routine Activities	10/3
Table 10.2	“Assessed” SD2 Infrastructure Project Routine and Non-routine Activities	10/4
Table 10.3	Socio Economic Impact Significance for Disruption/Access Restrictions to Natural Resources and Recreation	10/6
Table 10.4	Socio Economic Impact Significance for Employment Creation	10/8
Table 10.5	Socio Economic Impact Significance for Training and Skills Development	10/9
Table 10.6	Socio Economic Impact Significance for Procurement of Goods and Services	10/10
Table 10.7	Socio Economic Impact Significance for Construction Vehicle Movements (offsite)	10/12
Table 10.8	Socio Economic Impact Significance for Road Condition	10/13
Table 10.9	Socio Economic Impact Significance for Road and Railway Closures and Traffic Works	10/14
Table 10.10	Socio Economic Impact Significance for De-manning	10/15
Table 10.11	Summary of SD2 Infrastructure Project Residual Socio-Economic Impacts	10/17
Table 11.1	Oil Spill Response Tiers	11/16
Table 12.1	Key Requirements of the Contractors HSSE Management System	12/3
Table 13.1	Summary of Residual Environmental Impacts	13/2
Table 13.2	Summary of Residual Social-Economic Impacts	13/6

## Appendices

Appendix 2A	Shah Deniz Production Sharing Agreement Extract
Appendix 5A	Emissions Estimate Assumptions
Appendix 8A	Public Presentation Slides & Meeting Comments
Appendix 9A	SD2 Infrastructure Project Activities, Events and Interactions (Environment)
Appendix 9B	Visual and Lighting Screening Assessments
Appendix 9C	Air Quality Assessment For Construction
Appendix 9D	Noise Screening Assessment
Appendix 9E	Summary of Surface Water Modelling
Appendix 10A	SD2 Infrastructure Project Activities, Events and Interactions (Socio-Economic)

## Executive Summary

### Contents

E.1	Introduction.....	2
E.2	Project Overview and Need for an ESIA.....	2
E.3	Options Assessed and Terminal Expansion Planning.....	3
E.4	Assessment Methodology.....	3
E.5	Consultation and Disclosure.....	5
E.6	Environmental Impact Assessment.....	6
E.7	Socio-Economic Impacts.....	6
E.8	Cumulative, Transboundary and Accidental Events.....	8
E.9	Environmental and Social Management.....	9
E.10	Conclusions.....	9

### List of Figures

Figure E.1	Sangachal Terminal Location.....	2
Figure E.2	SD2 Infrastructure Scope of Work.....	3
Figure E.3	The ESIA Assessment Process.....	4

### List of Tables

Table E.1	Summary of Residual Environmental Impacts.....	6
Table E.2	Summary of Residual Socio-Economic Impacts.....	7

## Executive Summary

This Executive Summary presents a concise non-technical overview of the Shah Deniz 2 (SD2) Infrastructure Project Environmental and Socio-Economic Impact Assessment (ESIA). It is intended to provide a summary of the project design and activities, of the issues considered in the ESIA and of the main conclusions with respect to environmental and socio-economic impacts.

### E.1 Introduction

The Shah Deniz (SD) Contract Area is a high pressure gas-condensate field located in the Azerbaijan sector of the Caspian Sea. Development of the SD Contract Area, which is operated by BP Exploration (Azerbaijan) Limited on behalf of the other Production Sharing Agreement (PSA) consortium members, is being pursued in phases and to date has included the SD Stage 1 Project (SD1).

The SD 1 Project was approved in 2003 and production began in late 2006. SD1, via the SD Alpha (SDA) Platform, provides production from the SD reservoir. Onshore SD1 processing facilities are provided at the Sangachal Terminal located approximately 60km south of Baku (refer to Figure E.1). The SD2 Project represents the second development stage of the SD Contract Area of which the SD2 Infrastructure Project represents the first major work onshore.

**Figure E.1 Sangachal Terminal Location**



### E.2 Project Overview and Need for an ESIA

The purpose of the SD2 Project is to further exploit the gas and condensate reserves within the offshore Shah Deniz Contract Area. The SD2 Infrastructure Project comprises the works needed prior to the construction of the new SD2 Project onshore facilities. The SD2 Expansion Area will provide processing facilities for the SD2 Project and will increase production beyond the SD1 planned 900 million standard cubic feet per day (mmscfd). Figure E.2 shows the location of the proposed SD2 Expansion Area adjacent to the existing Sangachal Terminal facilities.

**Figure E.2 SD2 Infrastructure Scope of Work**

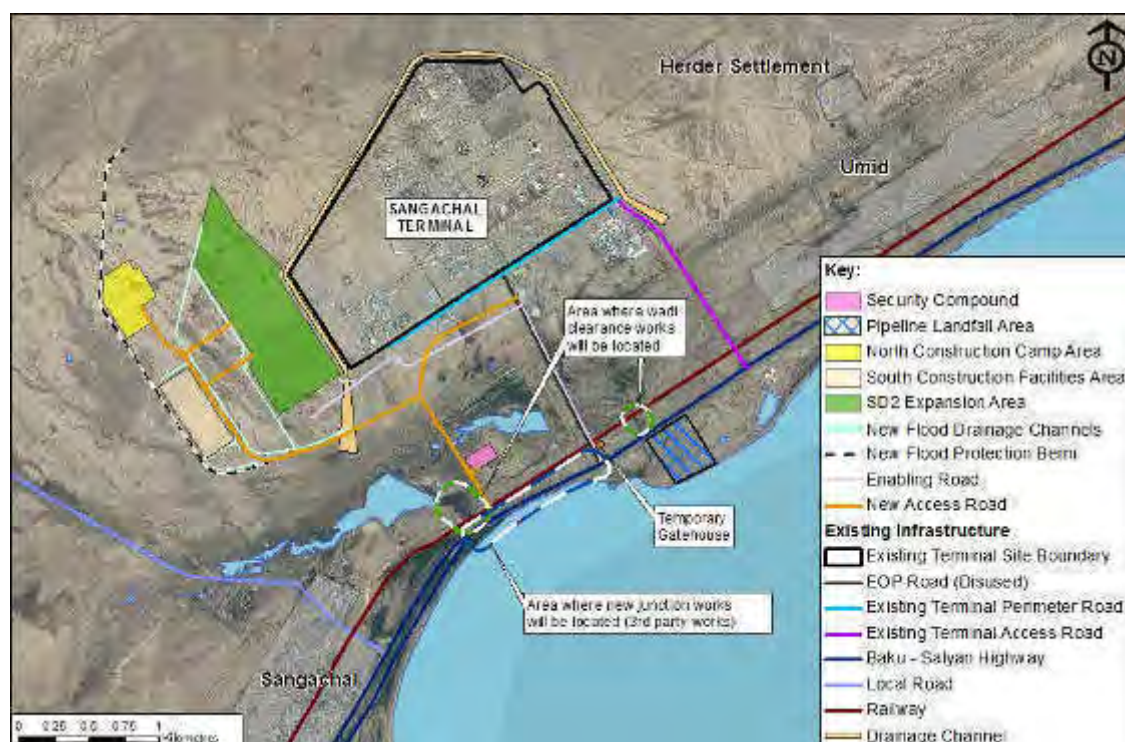

Given the location, scale and planned activities associated with the SD2 Infrastructure Project, it was agreed with the Ministry of Ecology and Natural Resources (MENR) that the project should be subject to an ESIA. Another ESIA will be prepared and submitted in 2012/2013 for the main SD2 Project works that will cover the construction and operation of the onshore and offshore gas and condensate production facilities.

### E.3 Options Assessed and Terminal Expansion Planning

It was determined that the SD2 facilities should be located adjacent to the existing Sangachal Terminal. The areas considered included areas to the east, north and west of the existing Terminal boundary. A suitable location was identified to the west of the Terminal.

Options assessed as part of the SD2 Infrastructure Project cover the following key aspects:

- New Terminal access road;
- Construction camp and construction facilities; and
- Drainage and flood protection design measures.

The potential locations of the project elements were informed by physical, environmental and safety constraints. On the basis of technical feasibility and as a result of consultations with stakeholders, an access road route was identified. Following the selection of the access route, it was determined that the construction camp and construction facilities should be located adjacent to the SD2 Expansion Area. Hydrological modelling and flood risk assessment work was also undertaken and has informed the access road location and design.

### E.4 Assessment Methodology

The ESIA assessment process adopted for the SD2 Infrastructure Project, as illustrated in Figure E.3, constitutes a systematic approach to the evaluation of the project and its associated activities throughout the project lifecycle from pre-construction to construction.

**Figure E.3 The ESIA Assessment Process**

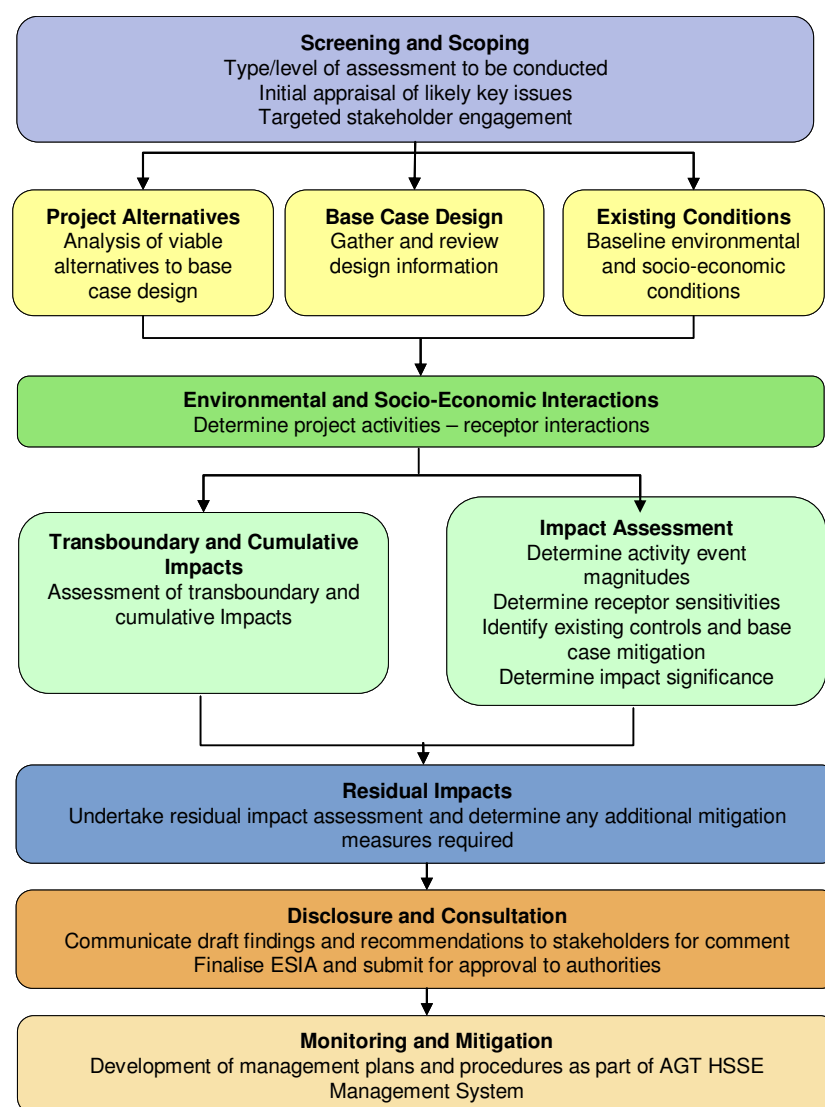

Assessment of SD2 Infrastructure Project environmental and socio-economic impacts has been undertaken based on the identification of SD2 Infrastructure Project activities and events for each project phase that have the potential to interact with the environment and socio-economic receptors.

The expected significance of environmental impacts has been assessed taking into account:

- **Event Magnitude:** Determined based on the following parameters:
  - **Extent** – the size of the area that is affected by the activity being undertaken;
  - **Duration** – the length of time that the activity occurs;
  - **Frequency** – how often the activity occurs; and
  - **Intensity of the impact** - concentration of an emission or discharge with respect to standards of acceptability that include applicable legislation and international guidance, its toxicity or potential for bioaccumulation, and its likely persistence in the environment.
- **Receptor Sensitivity:** Determined based on:
  - **Presence** – whether species/people are regularly present/transient, and whether species present are unique, threatened or protected; and

- **Resilience** – *how vulnerable people/species are to the change or disturbance associated with the environmental interaction with reference to existing baseline conditions and trends (e.g. trends in ecological abundance/diversity/status, ambient air quality etc).*

Socio-economic impacts have been assessed taking into account event magnitude, likelihood, and receptor sensitivity.

In order to identify the potential impact to receptors, an understanding of the existing conditions has been established. The SD2 Infrastructure ESIA Scoping exercise determined that the project will likely result in impacts on the following receptor groups:

- Biological/Ecological Receptors;
- Physical Receptor/Features;
- Soil, Ground Water and Surface Water Quality; and
- Socio-Economic/Human Receptors.

The evaluation of impacts has been based on the following principal sources of information:

- Meteorological data from the Baku State University National Hydrometeorological Department;
- Hydrology information from the Institute of Geography of the National Academy of Sciences of the Azerbaijan Republic;
- A number of specific surveys, including results of noise, odour, visual context and lighting surveys were undertaken to gather additional environmental data;
- A review of existing baseline conditions from 1996 to 2011, including results of the on-going Integrated Environmental Monitoring Programme (IEMP), which has regularly carried out 'regional' monitoring to identify and quantify natural environmental trends. Onshore surveys undertaken include ecological and air quality monitoring in and around the Terminal; and
- Data associated with existing socio economic conditions was obtained from secondary data sources including State Statistical data and data provided by the Garadagh Executive Committee. A Stakeholder and Socio Economic Survey (SSES) was also commissioned to obtain relevant up to date information to characterise socio-economic conditions within four local communities surrounding the Terminal.

## E.5 Consultation and Disclosure

The first stages of the Public Consultation and Disclosure process were initiated before drafting of the main ESIA document began. Scoping meetings were held in March and May 2011 to inform and receive comment from representatives from the key regulatory authorities and the Government to allow key issues to be incorporated into the ESIA scope. Scoping meetings were held with the MENR as well as meeting with the Garadagh Executive Committee, Ministry of Culture and Tourism (MoCT) and Institute of Archaeology and Ethnography (IoAE). The four local communities have been engaged through the SSES. Consultation with the SD2 Infrastructure Project Design Team has also been completed during the preparation of the SD2 Infrastructure Project ESIA.

The Draft ESIA report was submitted to the MENR and simultaneously released to public and stakeholder groups for comment. As part of the Draft ESIA consultation process, public meetings were held in Azim Kend, Sangachal Town and Umid during October 2011. Comments received on the Draft ESIA report were collated, analysed and responses issued where relevant. The ESIA was subsequently revised and finalised for MENR approval.



## E.6 Environmental Impact Assessment

Environmental impacts have been assessed for the SD2 Infrastructure Project and Table E.1 provides a summary of the residual impacts.

**Table E.1 Summary of Residual Environmental Impacts**

	Event	Event Magnitude	Receptor Sensitivity	Impact Significance
Atmosphere	Emissions from onsite and offsite construction plant and vehicles.	Medium	(Humans) Medium	Moderate Negative
	Emissions from surface soil layer removal and spoil movement.			
Noise	Noise emissions associated with construction activities.	Medium	(Humans) Medium	Moderate Negative
			(Biological/ Ecological) Medium	
Impact to the Terrestrial and Coastal Environment (Ecology)	Surface soil layer removal and spoil movement, drainage management works and Pipeline Landfall Area preparation.	Medium	(Biological/ Ecological) Medium	Moderate Negative
Impact to the Terrestrial Environment (Soil, Groundwater and Surface Water)	Excavation works and ground disturbance	Medium	(Soil) Medium	Moderate Negative
			(Surface Water) Medium	Moderate Negative
Impact to the Terrestrial and Coastal Environment (Cultural Heritage)	Impacts to cultural heritage due to earthworks and piling.	Medium	(Physical Receptors) Medium	Moderate Negative

## E.7 Socio-Economic Impacts

Socio-economic impacts have been assessed for SD2 Infrastructure Project and Table E.2 provides a summary of the residual impacts.



**Table E.2 Summary of Residual Socio-Economic Impacts**

Event	Magnitude		Probability	Receptor Sensitivity	Significance
	Spatial Scope	Timing and Duration			
<b>Direct Impacts</b>					
Disruption and access restrictions (SD2 Infrastructure Area)	Local	All SD2 Infrastructure area will be temporarily fenced during works to prevent unauthorised access.	Highly likely	Local herders – High	<b>Moderate – major negative</b>
		Temporary impact			
		Up to approximately 115 hectares will be permanently removed from use for herders.			
Disruption and access restrictions (Pipeline Landfall Area)	Local	The majority of the SD2 Infrastructure Area will be temporarily fenced during works (between March 2012 and June 2013).	Highly likely	Recreational fishermen - Low	<b>Negligible</b>
		Temporary impact	Highly likely	Commercial fishermen - Medium	<b>Negative</b>
			Highly likely	Recreational users - Low	<b>Negligible</b>
			Unlikely	Shoreline property values - Low	<b>Negligible</b>
Employment creation	Local	Employment will occur throughout the project, and is expected to peak between April 2012 and November 2012.	Highly likely	Local community - High	<b>Moderate-Major Positive</b>
	Regional	Temporary impact	Likely	Regional community – Medium	<b>Positive</b>
Training and skills development	Local	Training will commence prior to the project activities and continue throughout the project.	Highly likely	Local community – High	<b>Moderate-Major positive</b>
	Regional	Permanent	Highly likely	Local community – Medium	<b>Positive</b>
Procurement of goods and services	Local, and Regional	Procurement will take place throughout the project and benefits will cease shortly after the project finishes.	Highly likely	Local and regional businesses - High	<b>Moderate-Major positive</b>
	National	Temporary		National businesses - High	<b>Positive</b>
Disruption and impact to community safety associated with construction vehicle movements (offsite)	Local	Off site traffic movements will take place throughout the project.	Unlikely	Road users and local community – High	<b>Negative</b>
Temporary					
Deterioration in Road Conditions	Local	Changes to road condition from the transportation of construction materials will take place throughout the project and will cease after the project finishes.	Highly unlikely	Local Roads – High Main highway - Low	<b>Negligible</b>
Road and rail works	Local, and regional	Road and rail works are expected throughout the project but disruption is expected to be of short duration.	Highly likely	Local, regional and national businesses – High	<b>Negative</b>
Temporary					
De-manning	Local	De-manning will likely commence prior to end of the project as manning levels decrease however it is expected that the main SD2 Project will provide relevant employment opportunities for workers.	Unlikely	Local community – High	<b>Negligible</b>
Permanent					

## E.8 Cumulative, Transboundary and Accidental Events

Cumulative impacts, potential transboundary impacts and the impacts of accidental events associated with the SD2 Infrastructure Project have been assessed.

The potential for interaction between the different SD2 Infrastructure Project related residual impacts, resulting in a cumulative impact has been considered. The cumulative effect of all expected project activities will be managed through the implementation of a Nuisance Management Plan. The Plan will detail the processes used to prevent nuisance associated with construction noise, light from construction work areas, odours, pests and vermin. In addition a Community Interaction and Social Impact Management Plan will be implemented and maintained as a mechanism of communicating with the community and responding to community grievances.

Given the existing control measures in place, it is considered that the appropriate measures are in place to mitigate and manage potential cumulative effects between project related residual impacts.

Based on a review of available information, it is understood that the following projects (which have the potential to interact with the impacts of the SD2 Infrastructure Project based on their location and scale) are planned or under construction in the vicinity of the Terminal:

- **Qizildas Cement Plant** – To be located approximately 4km north of the Terminal;
- **Garadagh Dry Kiln Upgrade Project** – Upgrade to the existing Garadagh cement works (approximately 6km to the east) to install dry kiln technology and increase production; and
- **New Highway Junction** – Planned immediately to the south of the Terminal and planned to connect to the new Terminal access road, which forms part of the SD2 Infrastructure works.

The assessment of cumulative impacts demonstrated that negative cumulative impacts associated with the SD2 Infrastructure Project and other projects in the Terminal vicinity planned or under construction are expected to be limited.

The aspect with the greatest potential for negative impact is traffic disruption, assuming that the SD2 Infrastructure Project and the Qizildas Cement Plant construction schedules overlap. There is also potential for cumulative noise impacts at sensitive receptors associated with the SD2 Infrastructure Project and the Highway Junction. It will therefore, be necessary for the construction contractors and the Highways Authority to liaise to ensure these impacts are minimised through scheduling of works and use of appropriate mitigation measures.

There are also a number of significant positive cumulative impacts, primarily associated with employment and economic flows.

Accidental events are considered separately from routine and non-routine activities as they only arise as a result of a technical failure, human error or as a result of natural phenomena such as a seismic event.

Potential accidental events associated with the SD2 Infrastructure Project works include:

- Impact to a pipeline(s) within the existing pipeline corridor during construction activities;
- Loss of containment from fuel tanks within the construction camp/facilities area;
- Loss of containment from a fuel bowser, drum, Intermediate Bulk Container or fuel transfer container;
- Minor spills associated with leaks/small spills;
- Failure of the sewage treatment plant;
- Overflow of underground oil separators or septic tanks;
- Release of concrete into watercourses or the Caspian Sea; and
- Flood events causing silty water runoff from stockpiles and exposed ground.

Measures to mitigate accidental events have been incorporated at the project design stage and include:

- Pipeline mapping and condition assessment of existing pipelines;
- Construction of culverts/crossings over existing pipelines;
- Use of concrete barriers and buried pipeline protection on the EOP road;
- Bunding and containment; and
- Design of underground and septic tanks.

In addition, procedures and controls will be implemented during the construction to ensure that there is a minimum risk of spills. Key controls include:

- Production of site drainage and pollution hazard maps, showing the sources of potential pollution pathways and key receptors;
- Provision of adequate training in spill response for all personnel; and
- Maintenance of a spills register documenting key details of all spills including remediation works, if required.

Furthermore, a Spill Response Plan will be prepared prior to commencing work on the SD2 Infrastructure Project. This document will be aligned with BP's Oil Spill Response Plans (OSRP) and integrate with those plans maintained by the 3rd party pipeline owners that operate those pipelines over which crossings will be installed.

## **E.9 Environmental and Social Management**

The SD2 Infrastructure works will be performed by key contractors, appointed by BP. A rigorous contractor selection process will be in place to ensure that key contractors used during the SD2 Infrastructure Project have effective HSSE Management Systems that align with BP expectations.

The appointed contractor(s) will be required to develop, implement and monitor environment and social requirements through the HSSE Management System (aligned with ISO 14001 and OHSAS 18001 Standard).

The environmental and social management process will benefit from accumulated experience and 'lessons learned' from executing previous projects and a well-established environmental monitoring programme. Other benefits of previous project experience include the development of:

- Effective and reliable procedures for onsite segregation and management of waste;
- A non-hazardous landfill site designed and constructed to EU standards; and
- An effective process for identifying and utilising opportunities for waste recovery and recycling.

## **E.10 Conclusions**

Planning for the SD2 Infrastructure Project has benefited, to a considerable extent, from the experience gained from previous construction projects at the Terminal. Lessons learnt from previous projects have informed the SD2 Infrastructure Project.

In conclusion, the SD2 Infrastructure Project has considered all aspects of its impact on the environmental and socio-economic receptors and incorporated additional mitigation to existing controls to ensure any negative impacts are minimised as far as practicable.



## Units and Abbreviations

### Units

dB	Decibel
dB (A)	A weighted unit of sound intensity weighted in favour of frequencies audible to the human ear
dB <sub>L<sub>AEQ</sub></sub>	Sound pressure level
ha	Hectare
HP	Horsepower
hr	Hour
kg	Kilograms
km	Kilometre
km <sup>2</sup>	Square kilometre
Ktonnes	Kilo tonnes
kVA	Kilovolt- ampere
kW	Kilowatts
l	Litres
m	Metre
m/s	Metres per second
m <sup>2</sup>	Square metre
m <sup>3</sup>	Cubic metre
m <sup>3</sup> /day	Cubic metres per day
m <sup>3</sup> /hour	Cubic metres per hour
μ	Microns
μm	Micrometres
μg	Micrograms
μg/g	Micrograms per gram
μg/m <sup>3</sup>	Micrograms per cubic metre
μg/l	Micrograms per litre
mg	Milligrams
mg/l	Milligrams per litre
mg/m <sup>2</sup> /s	Milligrams per square metre per second
ml	Millilitres
mm	Millimetre
Mm <sup>3</sup>	Million cubic metres
mm/month	Millimetres per month
mmscf	Million standard cubic feet
mmscf/d	Million standard cubic feet per day
mph	Miles per hour
m/s	Metres per second
pH	-log <sub>10</sub> [H <sup>+</sup> ] (measure of acidity or alkalinity)
PM <sub>10</sub>	Particulate matter measuring less than 10μm in diameter
ppm	Parts per million
1Q	A quarter of one year
s	Second
US\$	US dollars
US\$M	US dollars (Millions)
%	Percent
°C	Degrees Celsius
>	Greater than
<	Less than

## Chemicals, Elements and Compounds

As	Arsenic
Ba	Barium
BTEX	Benzene, toluene, ethylbenzene, xylene
Cd	Cadmium
CH <sub>4</sub>	Methane
CO <sub>2</sub>	Carbon Dioxide
Cr	Chromium
Cu	Copper
Fe	Iron
Hg	Mercury
MEG	Mono Ethylene Glycol
NO	Nitrous Oxide
NO <sub>2</sub>	Nitrogen Dioxide
NO <sub>x</sub>	Nitrogen Oxides
PAH	Poly aromatic hydrocarbons
Pb	Lead
SO <sub>x</sub>	Sulphur Oxides
SO <sub>2</sub>	Sulphur Dioxide
Zn	Zinc

## Abbreviations

ACG	Azeri-Chirag-Gunashli
ACG1	Azeri-Chirag-Gunashli Phase 1
AGT	Azerbaijan Georgia Turkey
ANAS	Azerbaijan National Academy of Sciences
AZN	Azerbaijan Manat
AzRDB	Azerbaijan Red Data Book
BC	Before Christ
BOD	Biological Oxygen Demand
BPEO	Best Practicable Environmental Option
BS	British Standard
BST	Business Support Team
BTC	Baku-Tbilisi-Ceyhan
C&EA	Communications and External Affairs
CCSCP	Condensate and Chemical Spill Contingency Plan
CITES	Convention on International Trade in Endangered Species of Wild Fauna and Flora
COD	Chemical Oxygen Demand
COP	Chirag Oil Project
CWAA	Central Waste Accumulation Area
CSR	Corporate Social Responsibility
E&P Forum	Exploration and Production Forum
EIA	Environmental Impact Assessment
EMTAG	Environmental Monitoring Technical Advisory Group
ENP	European Neighbourhood Policy
ENVIID	Environmental Issues Identification
EOP	Early Oil Project
EPS	Environmental Protection Standards
ERA	Environmental Risk Assessment
ESC	Environmental Sub-Committee
ESIA	Environmental and Socio-Economic Impact Assessment
EU	European Union
FAO	Food and Agricultural Organisation
FOC	Foreign Oil Companies
GDP	Group Defined Practice
GHG	Greenhouse Gases
GOST	<i>Gosudarstvennyye Standarty</i> State Standard (Russian standard)

---

GP	General Practitioner
GRP	Group Recommended Practice
HSE	Health, Safety & Environment
HSSE	Health, Safety, Security and Environment
IADC	International Association of Drilling Contractors
IAGC	International Association of Geophysical Contractors
IDP	Internally Displaced Person
IEMP	Integrated Environmental Monitoring Programme
IFC	International Finance Corporation
ILE	Institute of Lighting Engineers
IMP	Impact Management Process
IMS	Incident Management System
IMT	Incident Management Team
IoAE	Institute of Archaeology and Ethnography
ISO	International Organisation for Standardisation
IUCN	International Union for the Conservation of Nature
JV	Joint Venture
L <sub>aeq</sub>	Equivalent average sound level
MEG	Mono ethylene glycol
MENR	Ministry of Ecology and Natural Resources
MES	Ministry of Emergency Situations
MoCT	Ministry of Culture and Tourism
MPC	Maximum Permissible Concentration
MPE	Maximum Permissible Emissions
MPN	Most Probable Number
MSDS	Material Safety Data Sheet
MSL	Mean Sea Level
Mt	Mount
NGO	Non Governmental Organisation
NMVOG	Non-methane Volatile Organic Compounds
OHSAS	Occupational Health and Safety and Advisory Service
OSRP	Oil Spill Response Plan
PAH	Poly Aromatic Hydrocarbons
PCA	Partnership and Cooperation Agreement
PCDP	Public Consultation and Disclosure Plan
PR	Production and Risers
PR	Performance Recommendations
PSA	Production Sharing Agreement
QU	Quarters and Utilities
RSL	Regional Screening Level
SCP	South Caucasus Pipeline
SD	Shah Deniz
SD1	Shah Deniz Stage 1
SD2	Shah Deniz 2
SDA	SD Alpha
SDB	SD Bravo
SEE	State Ecological Expertise
SME	Small and Medium Enterprises
SOCAR	State Oil Company of the Azerbaijan Republic
SOCIID	Social Impacts and Identification
SPU	Strategic Performance Unit
SRT	Site Response Team
SSES	Stakeholder and Socio-Economic Survey
STP	Sewage Treatment Plant
THC	Total Hydrocarbon Content
TOC	Total Organic Carbon
TPH	Total Petroleum Hydrocarbon
TSS	Total Suspended Solids
UK	United Kingdom
UN	United Nations

UNDP	United Nations Development Programme
UNECE	United Nations Economic Commission for Europe
UNESCO	United Nations Educational, Scientific and Cultural Organisation
UNFCCC	United Nations Framework Convention on Climate Change
URS	URS Corporation Ltd
USEPA	United States Environmental Protection Agency
VOC	Volatile Organic Compounds
WHO	World Health Organisation
WRA	Water Resource Associates
WTN	Waste Transfer Note



## Glossary

### Aarhus Convention

An international legal agreement which promotes access to information, public participation in decision making and access to justice in environmental matters.

### Accidental Events

Incidents or non-routine events that have the potential to trigger impacts that would otherwise not be anticipated.

### Ambient Levels

Sharing the same physical and/or chemical properties as the immediate surroundings.

### Anthropogenic

Relating to humans.

### Aromatic Hydrocarbons

Hydrocarbons which include cyclic conjugated carbon atoms such as benzene, toluene, xylene etc.

### Azerbaijan Manat (AZN)

Currency of Azerbaijan.

### Azeris or Azerbaijanis

People of the Republic of Azerbaijan.

### Background Level

The concentration of a substance or energy intensity level (such as noise or light) that is characteristic of the surrounding environment.

### Ballast

Course gravel or crushed rock laid to form a bed for road or railway lines.

### Base Case Design

Project design as described and assessed within the ESIA.

### Birth Rate

Childbirth per 1,000 people per year.

### Black Water

Human generated wastewater containing faecal matter and urine.

### Borehole

A hole in the ground made by drilling.

### Bored Piles

Concrete pile which is screwed into the ground to support a structure which has a heavy vertical load.

### Bowsers

A vehicle tanker containing fuel or water.

### Bund

Containment around a storage area to contain the contents in case of rupture or spillage.

### Caravanserai

An inn built around a large court for accommodating caravans along trade routes in central and western Asia.

### Cement

A powdery substance that acts as a binder that hardens (sets) after mixing with water. Cement is often used to bind aggregate materials (such as sand and gravel) together, to form concrete.

### Chal Meadow

Vegetation community that is linked to the temporary retention of surface water following rainfall, this community is dominated by *Tamarix meyeri* scrub and usually occurs in depressions and along drainage lines.

### Coliform

Of or relating to the bacteria that commonly inhabit the intestines/colons of humans and other vertebrates.

### Communities

A social group whose members reside in a specific locality, share government and often have a common cultural and historical heritage / an ecological unit composed of the various populations of micro-organisms, plants, animals that inhabit a particular area.

### Condensate (Gas Condensate)

Light hydrocarbon fractions produced with natural gas which condense into liquid at normal temperatures and pressures associated with surface production equipment.

### Consequence

The resultant effect (positive or negative) of an activity's interaction with the legal, natural and/or socio-economic environments.

### Consultation

A formal process which aims to obtain the views and opinions from stakeholders about a project.

**Continental Plate**

A tectonic plate that forms part of one of the Earth's continents.

**Contract Area**

Area of the sea that has been sub-divided and licensed/leased to a company or group of companies for exploration and production of hydrocarbons.

**Convergent plate boundary**

Where two continental plates converge.

**Crude Oil**

An unrefined mixture of naturally-occurring hydrocarbons with varying densities and properties.

**Culvert**

A man made structure used to channel water.

**Cumulative Impact**

Environmental and/or socio-economic aspects that may not on their own constitute a significant impact but when combined with impacts from reasonably foreseeable future activities, result in a larger /more significant impact(s).

**Decibel (dB)**

A unit used (one tenth of a bel) in the comparison of two power levels relating to sound intensities.

**Decommissioning**

Shutdown and dismantling of any facilities.

**Disclosure**

Release of ESIA information into the public domain.

**Domestic waste**

Waste, composed of garbage and rubbish, which normally originates from a residence/living quarters.

**Drainage Catchment**

The shape of the land which naturally forms different areas such that water falling as rain on the ground will drain into the lowest parts of the area.

**Dry Tree**

Device which controls the production from the surface/platform.

**Early Oil Project**

The first large-scale oil project in the Caspian Sea. It commenced in 1994 and

involved a consortium of companies who invested to extract oil from the Azeri, Chirag and Guneshli wells.

**Ecosystem**

The interrelationships between all living organisms in a given area, and their relationships to non-living materials.

**Effluent**

Waste products emitted as a liquid by an operation or process.

**Emergency / Abnormal Activity**

An unplanned activity e.g. due to equipment failure, loss of containment, operator error or design error.

**Embankment**

A raised mass of earth or stone built to hold back water or to support a roadway.

**Endemic**

Present within a localised area or characteristic to organisms in such an area.

**Environment for Europe**

A partnership of member states, including Azerbaijan, and other organisations within the UNECE region.

**Environmental and Socio-economic Impact Assessment (ESIA)**

The systematic identification and evaluation of environmental and socio-economic impacts linked to a project and its associated activities.

**Environmental Aspect**

An element of an organisation's activities, products or services that can interact with the environment and therefore requires a form of management.

**Environmental Impact**

Any change to the environment, whether adverse or beneficial, wholly or partially resulting from an organisation's activities, products or services.

**Environmental Management System**

A system established to plan, manage and document an organisation's activities and processes and resultant environmental impacts.

### **Environmental Receptors**

Any of various organisms that are directly or indirectly affected by environmental impact.

### **Ephemeral**

Something living or lasting for a brief time, such as the flow of a river during certain months of the year.

### **Espoo Convention**

A regional legal agreement to promote environmentally sound and sustainable economic development through the application of ESIA.

### **Ethnography**

The study of customs and the cultural heritage of separate ethnic and human groups and tribes.

### **Eurasian**

The extended landmass of Europe and Asia and specifically the large indeterminate region where the two continents join.

### **Fertility Rate**

The average number of children that would be born to a woman in a certain area over her lifetime.

### **Flood Plain**

A flood plain is a near flat land adjacent to a stream or a river which experiences flooding during periods of high discharge.

### **Flora/fauna**

Plants/wildlife that occur within a defined geographical area.

### **Footprint**

The spatial impact/impression on the land from a facility, building or disturbed area.

### **Geocell structures**

A layer of interconnecting strips of geogrids/geofabrics filled with granular material to create a stiffened basal layer which can be used to control differential settlement under embankments constructed on compressible ground.

### **Geotextile**

A strong synthetic fabric used in civil engineering to retain an embankment.

### **Greenhouse Gases (GHG)**

Atmospheric gases considered to contribute to the Earth's greenhouse effect

by absorbing and emitting radiation within the thermal infrared range. GHG include carbon dioxide and methane.

### **Habitat**

An area where a particular animal or plant species and assemblages are found, defined by environmental parameters.

### **Harmful Substances**

Those substances that are identified as marine pollutants in the IMDG Code.

### **Hazard**

The potential to cause harm, including ill health or injury; damage to property, plant, products or the environment; production losses or increased liabilities.

### **Heavy Metals**

Metallic elements with high atomic weights including mercury, chromium, cadmium, arsenic and lead.

### **Heritage**

Valued objects and qualities such as cultural traditions, unspoiled countryside, and historic building that have been passed down previous generations.

### **Hydrocarbon**

Organic chemical compounds of hydrogen and carbon atoms. There are a vast number of these compounds and they form the basis of all petroleum products. They may exist as gases, liquids or solids, examples being methane, hexane and paraffin.

### **Hydrology**

The science dealing with the occurrence, circulation, distribution, and properties of water of the earth and its atmosphere.

### **Impermeable**

Not allowing the passage of a fluid.

### **International Finance Corporation**

Organisation that is a member of the World Bank, and promotes sustainable private sector investment in developing countries.

### **Invertebrates**

Any animal lacking a backbone, including all species not classified as vertebrates.

### **Infiltration**

The flow of water from the land surface into the subsurface.

**ISO 14001**

An evolving series of generic environmental management system standards developed by the International Standards Organisation that provides business management with a structure for managing environmental impacts.

**Landfill**

Disposal of waste materials by burial.

**Law on Normative-Legal Acts**

Azerbaijani legislation that stipulates that acts in force prior to independence, not subsequently cancelled or contradictory to the Constitution, remain in force.

**Law on the Protection of the Environment**

Azerbaijani legislation that addresses use of natural resources, the rights and responsibilities of the State and its citizens, ecological requirements for economic activities, ecological emergencies and disaster zones, etc.

**Lay down area**

Temporary storage area for supplies and materials.

**Flood Levee**

An embankment designed to prevent the flooding of a river.

**Likelihood**

The possibility that an activity or effect will occur.

**Mammal**

A class of air-breathing, warm-blooded vertebrates.

**Meteorological dynamics**

The study of those motions of the atmosphere that is associated with weather and climate.

**Migration**

Movement of people to a new area or country in order to find work or better living conditions / any regular animal journeys along well-defined routes, particularly those involving a return to breeding grounds.

**Milli Mejlis**

Azerbaijan Parliament.

**Mitigation**

The measures put forward to prevent, reduce and where possible, offset any adverse environmental or socio-economic effects.

**Non Routine Activity**

An activity that occurs when plant / vessels or equipment is operated not as specified within the Base Case but in a previously planned manner.

**Operator**

The company responsible for conducting operations on a concession on behalf of itself and any other concession-holders.

**Overtopping**

The flow of water over a dam wall or embankment.

**Particulates**

Particles of solid or liquid suspended in a gas or liquid.

**pH**

A scale of alkalinity or acidity, running from 0 to 14 with 7 representing neutrality, 0 maximum acidity and 14 maximum alkalinity.

**Precipitation**

The product of atmospheric water vapour condensation that falls to the Earth's surface under gravity. The main types of precipitation are: drizzle, rain, sleet, snow and hail.

**Producer Well**

A drilled hole through which oil and gas is extracted.

**Piling**

A heavy beam of timber, concrete, or steel, driven into the earth as a foundation or support for a structure.

**Pipeline Landfall**

Location where an offshore pipeline reaches the coast.

**Platform**

A large structure offshore which has facilities to drill, extract, process and temporarily store hydrocarbons.

### **Pollution**

The introduction by man, directly or indirectly, of substances or energy to the environment resulting in deleterious effects such as harm to living resources; hazards to human health; hindrance of marine activities including fishing and impairment of the quality for use of seawater and reduction of amenities.

### **Production**

The full-scale extraction of hydrocarbon reserves.

### **Production Sharing Agreement (PSA)**

Type of contract signed between a government and a resource extraction company (or group of companies).

### **Public Participation**

Process where the public are informed about the planned activities.

### **RAMSAR Convention**

The intergovernmental treaty that provides designations to sites that are considered internationally important wetlands.

### **Receptor**

The aspect of the environment (air, water, ecosystem, human, fauna, etc.) that is affected by/interacts with an environmental or socio-economic impact.

### **Recycling/Recovery**

The conversion of wastes into usable materials and/or extraction of energy or materials from wastes.

### **Red List / Red Book**

A list comprised of rare or endangered species of plants and animals.

### **Reedbed**

Tall plants that grow in large groups in shallow water or on ground that is always wet and soft.

### **Reservoir**

A porous, fractured or cavitied rock formation with a geological seal forming a trap for producible hydrocarbons.

### **Residual Impacts**

Residual impacts are impacts that remain after mitigation measures, including those incorporated into the project's Base Case design and those developed in addition to the base design, have been applied.

### **Resilience**

A measure of how a biological, ecological or human receptor is affected by an identified stressor.

### **Reuse**

The use of materials or products that is reusable in their original form.

### **Richter Scale**

The scale for expressing the magnitude of an earthquake, ranging from 0 to 10.

### **Riser**

A pipe through which fluids flow upwards.

### **Routine Activity**

An activity that occurs during routine operations when plant / vessels or equipment is operating as specified within the design base case e.g. operation of the sewage treatment plant as designed.

### **Runoff Coefficient**

The ratio of the amount of water that is not absorbed by the surface to the total amount of water that falls during a rainstorm.

### **Scoping**

Early stage in the ESIA process which appraises the likely key issues requiring detailed assessment.

### **Scouring**

A form of erosion; removal by hydrodynamic forces of granular bed material in the vicinity of structures, such as roads and railway lines.

### **Screening**

The process by which it is decided if an ESIA is required to be carried out for a project.

### **Seismic**

The characteristics (e.g. frequency and intensity) of earthquake activity in a given region.

### **Sediment**

Any particular matter that is transported by fluid flow and subsequently deposited.

### **Sensitivity**

The recovery rate of flora or fauna from significant disturbance or degradation.

**Shrub**

A woody plant of relatively low height, having several stems from the base.

**Spoil**

Material generated during clearance /excavation works.

**Stakeholder**

A person, group and/or organisation with an interest in a project.

**Stockholm Convention**

An international legal agreement requiring Governments to reduce the release of persistent organic pollutants.

**Strata**

Distinct, usually parallel beds of rock.

**Transboundary impact**

An impact which crosses any boundaries between two geopolitical boundaries (i.e. a border).

**Unit hydrograph**

Graphical representation of stage, flow, velocity or other characteristics of water over a period of time.

**Vienna Convention**

An international legal agreement regarding the protection of the Ozone Layer.

**Wadi**

A river valley which may be ephemeral and flow only after heavy rain, or during certain periods of the year.

**Wastewater**

Water contaminated with domestic and production wastes.

**Wetland**

An area of land whose soil is saturated with moisture either permanently or seasonally.

**Well Completion**

The work of preparing a newly drilled well for production.

**World Heritage Site**

A site (such as a forest, mountain, lake, desert, monument, building, complex, or city) that is on the list that is maintained by the international World Heritage Programme administered by the UNESCO World Heritage Committee.

## 1. Introduction

### Contents

1.1	Introduction.....	2
1.1.1	Shah Deniz Production Sharing Agreement.....	3
1.1.2	Previous Terminal Development.....	3
1.2	SD2 Infrastructure Project Overview.....	4
1.3	SD2 Infrastructure Environmental and Social Impact Assessment .....	4
1.3.1	Objectives.....	4
1.3.2	ESIA Team and Structure .....	5

### List of Figures

Figure 1.1	Sangachal Terminal Location .....	2
Figure 1.2	SD2 Infrastructure Project Scope of Work.....	4

### List of Tables

Table 1.1	Onshore Scope of Works Assessed Within Previous ACG and SD ESIA.....	3
Table 1.2	SD2 Infrastructure Project ESIA Team .....	5
Table 1.3	Structure and Content of the ESIA.....	5

## 1.1 Introduction

The Shah Deniz (SD) Contract Area is a high pressure gas-condensate field located in the Azerbaijan sector of the Caspian Sea.

Shah Deniz Stage 1 (SD1) entered the Operate phase with first gas achieved during the fourth quarter of 2006. SD1, via the SD Alpha (SDA) platform, provides production from the SD reservoir. Onshore SD1 processing facilities are provided at the Sangachal Terminal, located approximately 60km south west of Baku (refer to Figure 1.1).

**Figure 1.1 Sangachal Terminal Location**



SD1 is a 'localised, stand alone' development with little opportunity, beyond limited debottlenecking opportunities, to increase production beyond the originally planned 900 million standard cubic feet per day (mmscfd).

The Shah Deniz 2 (SD2) Project, the second stage of SD field development, is planned to comprise:

- A fixed SD Bravo (SDB) platform complex including Production and Risers platform (SDB-PR) and a Quarters and Utilities (SDB-QU) platform, bridge linked to the SDB-PR;
- Subsea manifolds and associated well clusters, tied back to the fixed SD Bravo (SDB) platform complex by flowlines; and
- Subsea export pipelines from the SDB-PR platform to the Terminal and a dedicated monoethylene glycol (MEG) import pipeline from the Terminal to the SDB-PR platform.

The Terminal will be expanded to provide processing facilities for the SD2 Project.

The purpose of this Environmental & Socio-Economic Impact Assessment (ESIA) is to assess the environmental and socio-economic impacts associated with the works required prior to the construction, installation, commissioning and operation of the onshore SD2 facilities within the SD2 Expansion Area at the Sangachal Terminal.

The environmental and socio-economic impacts associated with the following SD2 Project activities will be assessed and reported separately:



- Construction, installation, hook up and commissioning of the onshore, offshore and subsea facilities (including the SD2 export and MEG pipelines to the Terminal);
- Drilling and well completion; and
- Operation of the offshore and onshore SD2 Project facilities.

The SD2 Infrastructure Project will be carried out taking into account applicable national and international legal requirements, and in accordance with the requirements of BP's Azerbaijan Georgia Turkey (AGT) Region Local Operating Management System.

### 1.1.1 Shah Deniz Production Sharing Agreement

The SD Production Sharing Agreement (PSA) was signed on 4th June 1996 between the State Oil Company of the Azerbaijan Republic (SOCAR) and a consortium of Foreign Oil Companies (FOC) to develop and manage the reserves of the SD gas-condensate field, herein after termed "Contract Area". BP Exploration (Azerbaijan) Limited have been appointed Operator of the PSA on behalf of the consortium partners. The consortium partners of SD are as follows:

- BP 25.5%
- Statoil 25.5%
- TOTAL 10.0%
- Lukoil 10.0%
- NICO 10.0%
- TPAO 9.0%
- SOCAR 10.0%

### 1.1.2 Previous Terminal Development

Phased expansion of the Sangachal Terminal has been undertaken over the past 10 years to accommodate the additional processing and ancillary facilities required to support the phased development of the Azeri-Chirag-Guneshli (ACG)<sup>1</sup> and SD Contract Areas. ESIA's have been completed for each development phase as detailed within Table 1.1.

**Table 1.1 Onshore Scope of Works Assessed Within Previous ACG and SD ESIA's**

ESIA	Project Scope
Early Civils (2001)	<ul style="list-style-type: none"> <li>• Clearing and grading of: <ul style="list-style-type: none"> <li>• ACG1 and SD1 Terminal facility areas located directly to the west of the Early Oil Project (EOP) facilities and;</li> <li>• BTC pumping and metering station location, adjacent to the EOP facilities to the north.</li> </ul> </li> <li>• Excavation of a drainage channel around the Terminal boundary.</li> <li>• Construction of perimeter fencing, lighting and a bund wall.</li> <li>• Construction of a new access road to the Terminal and railway crossing.</li> <li>• Relocation and modification of utilities services.</li> </ul>
ACG Phase 1 (2002)	<ul style="list-style-type: none"> <li>• Construction, installation and operation of additional oil receiving and stabilisation facilities at Sangachal Terminal (within the Terminal boundary located directly to the west of the EOP facilities).</li> <li>• Construction of construction camp (including waste water treatment plant) directly to the south of the Terminal boundary.</li> </ul>
SD Stage 1 (2002)	<ul style="list-style-type: none"> <li>• Construction, installation and operation of onshore reception, gas-processing and condensate facilities located adjacent to and integrated with the ACG facilities at Sangachal Terminal.</li> </ul>
ACG Phase 2 (2003)	<ul style="list-style-type: none"> <li>• Construction, installation and operation of additional oil receiving and stabilisation facilities at Sangachal Terminal (within the Terminal boundary located directly north of the ACG Phase 1 facilities).</li> </ul>
ACG Phase 3 (2004)	<ul style="list-style-type: none"> <li>• Construction, installation and operation of additional oil receiving and stabilisation facilities at Sangachal Terminal (within the Terminal boundary located directly north of the ACG Phase 2 facilities)</li> </ul>
ACG FFD PWD (2007)	<ul style="list-style-type: none"> <li>• Construction, installation and operation of produced water treatment facilities (within the Terminal boundary located directly north of the BTC pumping and metering station)</li> </ul>

<sup>1</sup> The SD and ACG Contract Areas lie approximately 66km east and 135km north east from the Sangachal Terminal respectively.

## 1.2 SD2 Infrastructure Project Overview

The main components of the SD2 Infrastructure Project comprise (refer to Figure 1.2):

- Temporary reinstatement of the Early Oil Project Terminal access road;
- New access road from the Baku-Salyan highway to the Sangachal Terminal (and associated facilities);
- Clearance and terracing of the SD2 Expansion Area, located immediately to the west of the existing Terminal;
- Construction and fit out of the construction camp and construction facilities;
- Installation and operation of a sewage treatment plant;
- Installation of storm water drainage and surface water/flood protection berms; and
- Levelling of the SD2 Pipeline Landfall Area.

**Figure 1.2 SD2 Infrastructure Project Scope of Work**

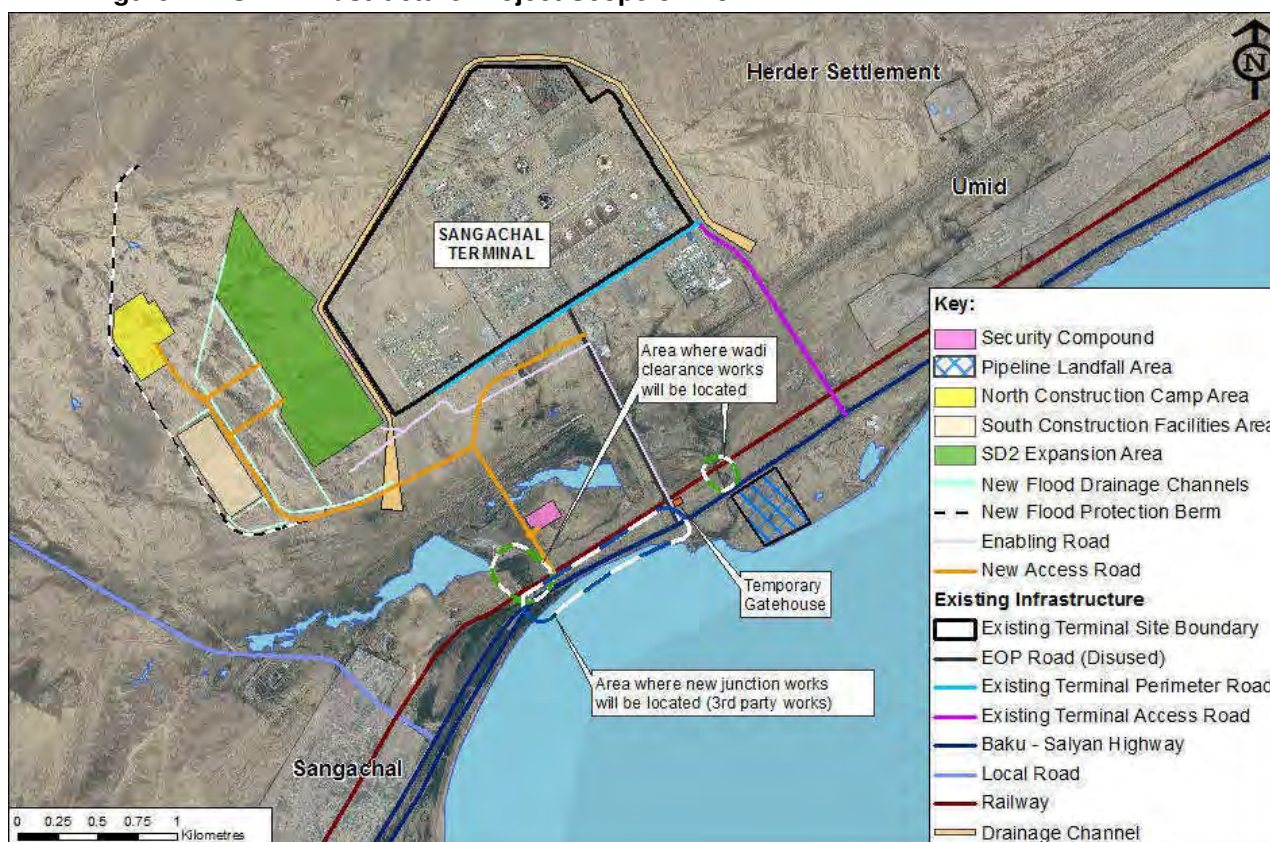

## 1.3 SD2 Infrastructure Environmental and Socio-Economic Impact Assessment

### 1.3.1 Objectives

The overall objective of the SD2 Infrastructure Project ESIA process is to ensure that adverse environmental or socio-economic impacts arising from proposed works are identified and, where possible, eliminated or minimised.

The purpose of the ESIA is to:

- Ensure that environmental and socio-economic considerations are integrated into project design and operation;
- Ensure that previous experience is acknowledged and where appropriate, integrated into the project design;

- Ensure that environmental and socio-economic impacts are identified, quantified and assessed and appropriate mitigation measures proposed;
- Ensure that a high standard of environmental and socio-economic performance is planned and achieved for the project;
- Ensure that applicable legal, operator and PSA requirements and expectations are addressed;
- Consult with relevant stakeholders throughout the project and address their concerns; and
- Demonstrate that the project will be implemented with due regard to environmental and socio-economic considerations.

Within the impact assessment, activities and potential receptor interactions are evaluated against existing environmental and socio-economic conditions and sensitivities, and the potential impacts are ranked. The assessment of potential impacts takes account of existing and planned controls and monitoring and mitigation measures developed as part of earlier ACG and SD Projects.

### 1.3.2 ESIA Team and Structure

The details of the SD2 Infrastructure Project ESIA Team are provided in Table 1.2.

**Table 1.2 SD2 Infrastructure Project ESIA Team**

Team Member	Role
URS	ESIA Project Manager and Lead Authors
The Social Consultancy	Socio-Economic Specialist
WRA	Hydrology Specialist
Synergetics	Local Socio-Economic Specialists
KBR	Project Engineers
BP	SD Contract Area PSA Operator on behalf of SD PSA Partners

Table 1.3 provides a summary of the SD2 Infrastructure Project ESIA structure and content.

**Table 1.3 Structure and Content of the ESIA**

Section/Chapter	Content
<b>Executive Summary</b>	A summary of the ESIA
<b>Units and Abbreviations</b>	A list of the units and abbreviations used in the ESIA.
<b>Glossary</b>	A glossary of terms.
1 Introduction	A general introduction to the SD2 Infrastructure Project, the objectives of the assessment, and the report structure of the ESIA.
2 Policy, Regulatory and Administrative Framework	A summary of the composition and HSE policies of the project proponent, the HSE requirements set out in the Shah Deniz PSA, relevant international and national environmental standards and guidelines.
3 Impact Assessment Methodology	A description of the methods used to conduct the ESIA.
4 Options Assessed	A description of the alternative concept options assessed for the SD2 Infrastructure Project.
5 Project Description	A detailed description of the SD2 Infrastructure Project.
6 Environmental Description	A description of the environmental baseline conditions in the vicinity of the SD2 Infrastructure area.
7 Socio-Economic Description	A description of the socio-economic baseline conditions in the vicinity of the SD2 Infrastructure area.
8 Consultation and Disclosure	An overview of the consultation undertaken during the ESIA and key issues raised.
9 Environmental Impact Assessment, Mitigation and Monitoring	An assessment of the potential environmental impacts associated with the SD2 Infrastructure Project activities.
10 Socio-Economic Impact Assessment, Mitigation and Monitoring	An assessment of the potential socio-economic impacts associated with the SD2 Infrastructure Project activities.
11 Cumulative and Transboundary Impacts and Accidental Events	An assessment of the potential cumulative and transboundary impacts and accidental events associated with the SD2 Infrastructure Project.
12 Environmental and Social Management	A summary of the environmental and social management system associated with the SD2 Infrastructure Project activities.
13 Residual Impacts and Conclusions	A summary of the residual impacts and conclusions arising from the ESIA process.
<b>Appendices</b>	Supporting technical information.



## 2 Policy, Regulatory and Administrative Framework

### Contents

2.1	Introduction.....	2
2.2	The Constitution .....	2
2.3	Production Sharing Agreement .....	2
2.4	National Environmental Legislation.....	7
	2.4.1 National EIA Guidance.....	11
2.5	Regional Processes .....	12
	2.5.1 European Union .....	12
	2.5.2 Environment for Europe .....	12
2.6	International Petroleum Industry Standards and Practices.....	12
2.7	BP Requirements .....	13

### List of Figures

Figure 2.1	Azerbaijan Legal Hierarchy.....	2
------------	---------------------------------	---

### List of Tables

Table 2.1	Summary of International Conventions .....	5
Table 2.2	Summary of Regional Conventions .....	6
Table 2.3	Key National Environmental and Social Laws .....	8
Table 2.4	Summary of Guidance on the EIA Process in Azerbaijan .....	11



## 2.1 Introduction

The Shah Deniz 2 (SD2) Infrastructure Project will be undertaken in accordance with the Agreement on the Exploration, Development and Production Sharing for Shah Deniz Prospective Area in the Azerbaijan Sector of the Caspian Sea (referred to herein as the "PSA"), applicable requirements of international conventions ratified by the Azerbaijan government, international petroleum industry standards and practices, applicable national legislation and BP's Health Safety Security and Environment (HSSE) Policy. The legal hierarchy applicable to the SD2 Infrastructure Project is illustrated in Figure 2.1.

**Figure 2.1 Azerbaijan Legal Hierarchy**

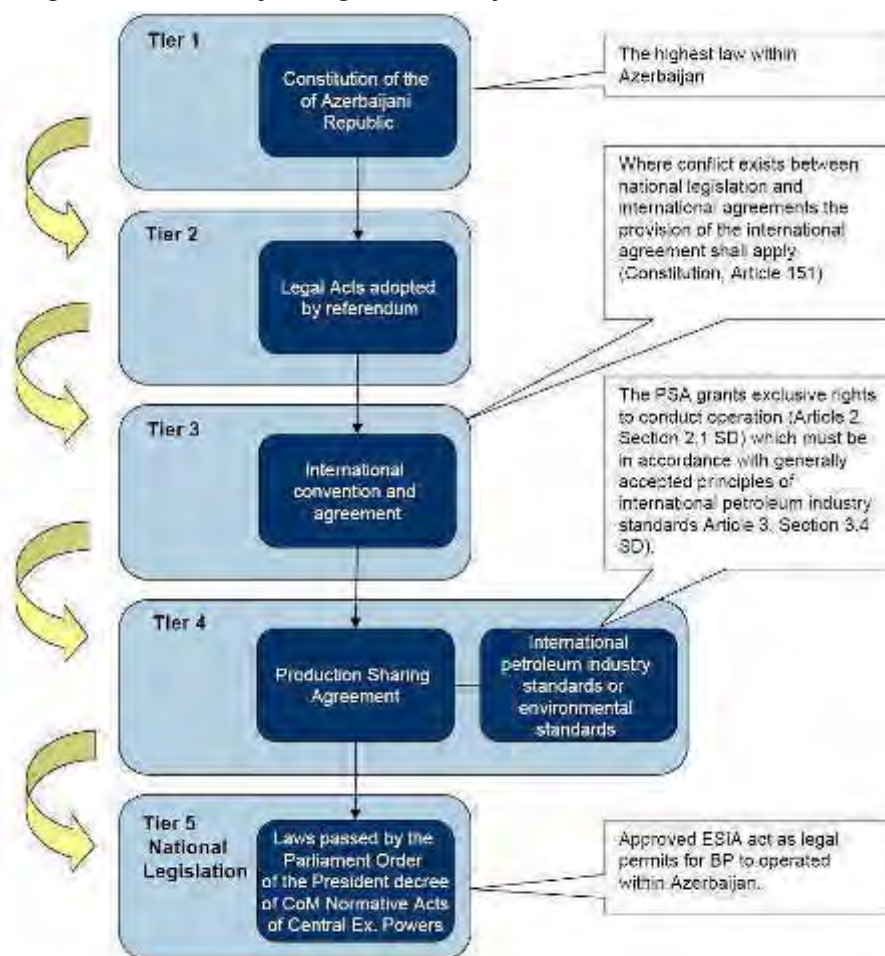

## 2.2 The Constitution

The Constitution is the highest law in the Azerbaijan Republic and prevails over national legislation and international agreements. It stipulates the basic rights of people to live in a healthy environment, to have access to information on the state of the environment and to obtain compensation for damage suffered as the result of a violation of environmental legislation.

## 2.3 Production Sharing Agreement

The PSA establishes the legal regime for the joint development and production sharing of the Shah Deniz field. This agreement, signed by BP and its co-venturers as Contractor Parties and the State Oil Company of the Republic of Azerbaijan (SOCAR) was entered into in Baku in June 1996. It was subsequently enacted into the law of the Republic of Azerbaijan after ratification by the Parliament on 17<sup>th</sup> October 1996. BP Exploration (Shah Deniz) Limited is

acting as the Technical Operator for and on behalf of SD PSA participants in accordance with a Joint Operating Agreement and the Operator Services Agreement.

The PSA states that the conduct of operations should be undertaken with respect to the general environment, other natural resources and property, with the order of priority being the protection of life, environment and property.

Article 26.1 of the PSA states:

*“Contractor shall develop jointly with SOCAR and the State Committee of the Azerbaijan Republic on Ecology and Control over the Use of Natural Resources (“SCE”) safety and environmental protection standards and practices appropriate for the relations of Petroleum Operations<sup>1</sup>”*

Article 26.1 also requires that in developing relevant standards and practices, environmental quality objectives, technical feasibility and economic and commercial viability must also be taken into account (refer to Appendix 2A for SD PSA extract) and further states:

*“Subject to the first sentence of Article 26.4 the standards, which shall apply to Petroleum Operations from Effective Date shall be the standards and practices set out in part II of Appendix IX until substituted by new safety and environmental protection standards devised and agreed between Contractor, SOCAR and SCE on a date between the Parties and SCE and from such date such agreed standards and practices shall have the force of law as if set out in full in the Agreement.”*

In response to the requirement under Article 26.1 of the PSA, SD specific Environmental Protection Standards (EPS) have been developed and have been formally approved via signed letters from SOCAR and the MENR in 1998. Technical work on development of the Environmental Production Standards began in 2001. Production Standards have been approved by Shah Deniz Co-venturers. The protocol for their entrance into legal force has been signed by BP on behalf of the SD partners and SOCAR, but has yet to be signed by the MENR. The following SD EPS documents have been developed:

- **SD EPS: Approval and Permitting** – details the permitting and approval process for SD projects and activities resulting in potential environmental impacts.
- **SD EPS: Environmental Planning and Environment** – provides an overview of environmental management requirements for SD projects.
- **SD EPS: Environmental Risk Assessment and Management** – details the EPS to be complied with by the Operator for the purposes of conducting Environmental Risk Assessments (ERA) associated with the execution of SD projects.
- **SD EPS: Standards for Environmental Quality** – details the preliminary Maximum Permissible Concentration (MPC) of pollutants which will be used as the basis for deriving EPS which will be applied to discharges and emissions to the environment.
- **SD EPS: Discharges and Emissions** – describes the EPS to be complied with by the Operator and all contractors involved in the execution of SD projects for the purpose of controlling emissions and discharges to the environment.
- **SD EPS: Chemical Selection and Management** – details the EPS to be complied with for the purposes of chemical selection and management by the Operator and all contractors involved in the execution of SD projects.
- **SD EPS: Condensate and Chemical Spill Contingency Planning** – details the EPS to be complied with by the Contractor and all Subcontractors involved in the execution of SD projects for the purposes of condensate and chemical spill contingency planning (CCSCP).
- **SD EPS: Waste Management** – details the EPS to be complied with by the Operator and all contractors involved in the execution of SD projects for the purposes of waste

<sup>1</sup> The PSA defines petroleum operations as: “all operations relating to the exploration, appraisal, development, extraction, production, stabilisation, treatment (including processing of natural gas), stimulation, injection, gathering, storage, handling, lifting, transporting petroleum to the delivery point and marketing of petroleum from, and abandonment operations with respect to the Contract Area”.

management to ensure waste will be managed in an environmentally safe manner from the site of waste generation to the point of final disposal.

Accordingly, until the protocol on entrance into legal force of the Production Standards has been signed by all of the parties, the standards and practices set out in part II of Appendix IX to the PSA shall continue to apply to production activities.

Article 26.4 of the PSA requires BP Exploration (Azerbaijan) Limited to: “...*comply with present and future Azerbaijani laws or regulations of general applicability with respect to public health, safety and the protection and restoration of the environment, to the extent that such laws and regulations are no more stringent than the Environmental Standards.*”

Appendix 9 of the PSA describes the standards and practices common for international petroleum industry that were in existence at the time when the PSA was signed. Tables 2.1 and 2.2 provide a summary of international and regional conventions, which form part of the current international petroleum industry framework.



**Table 2.1 Summary of International Conventions**

Convention	Purpose	Status
UN Framework Convention on Climate Change.	To collate information on greenhouse gas emissions and cooperate in planning.	Azerbaijan not formally required to meet specific reduction targets.
Bern Convention.	Conservation of wild flora and fauna and their natural habitats.	In force in Azerbaijan since 2002.
UNESCO Convention on Wetlands of International Importance especially as Waterfowl Habitat / RAMSAR Convention.	Promote conservation of wetlands and waterfowl. In addition, certain wetlands are designated as Wetlands of International Importance and receive additional protection.	Azerbaijan signed the Ramsar Convention in 2001.
Stockholm Convention on Persistent Organic Pollutants.	Reduction in releases of dioxins, furans, hexachlorobenzene and PCBs with the aim of minimisation or elimination.	Azerbaijan acceded in 2004.
UN Convention on the Protection of the Ozone Layer (Vienna Convention).	Framework for directing international effort to protect the ozone layer, including legally binding requirements limiting the production and use of ozone depleting substances as defined in the Montreal Protocol to the Convention.	Azerbaijan acceded in 1996.
UN Convention on Biological Diversity.	Conservation of biological diversity including the sustainable use of its components and the fair and equitable sharing of benefits.	Azerbaijan became party to the Convention in 2000.
FAO Plant Protection Convention.	A treaty to prevent the spread and introduction of pests of plants and plant products and to promote measures for their control.	Entered into force in Azerbaijan in 2000.
Convention to Combat Desertification.	To combat desertification and mitigate the effects of drought.	Entered force in Azerbaijan in 1998.
Convention on International Trade in Endangered Species of Wild Fauna and Flora (CITES).	Controls trade in selected species of plant and animals.	Entered into force in Azerbaijan in 1999.
Convention for the Protection of the Archaeological Heritage of Europe.	Requires each state party to support archaeological research financially and promote archaeology, using public or private funding as the case may be.	Azerbaijan ratified in 2000.
UNESCO Convention on the Protection and Promotion of the Diversity of Cultural Expressions.	Promotes participants' right to formulate and implement their cultural policies and to adopt measures to protect and promote the diversity of cultural expressions and to strengthen international cooperation.	Azerbaijan acceded in 2010.

**Table 2.2 Summary of Regional Conventions**

Convention	Purpose	Status
Aarhus Convention*.	To guarantee the rights of access to information, public participation in decision-making and access to justice in environmental matters.	Azerbaijan acceded in 2000.
Espoo Convention*.	To promote environmentally sound and sustainable development through the application of ESIA, especially as a preventive measure against transboundary environmental degradation.	Azerbaijan acceded in 1999. At the time of writing, Azerbaijan had not signed a related protocol on Strategic Environmental Assessment.
Convention on the Protection and Use of Transboundary Watercourses and International Lakes (Helsinki Convention)*.	To prevent, control or reduce and transboundary impact resulting from the pollution of transboundary waters by human activity.	Azerbaijan acceded in 2002.
UN Convention on Control of Transboundary Movements of Hazardous Wastes and their Disposals.	Regulates the transboundary movements of hazardous wastes and provides obligations to its Parties to ensure that such wastes are managed and disposed of in an environmentally sound manner.	Azerbaijan ratified in 2001.
Protocol on Water and Health*.	To protect human health and well-being by better water management and by preventing, controlling and reducing water-related diseases.	Azerbaijan acceded in 2003.
UNECE Geneva Convention on Long-range Transboundary Air Pollution*.	Provides a framework for controlling and reducing transboundary air pollution.	Entered into force in Azerbaijan in 2002. Has been extended by 8 protocols, none of which at the time of writing have been ratified by Azerbaijan.
Convention on the Transboundary Effects of Industrial Accidents*.	To prevent industrial accidents that may have transboundary effects and to prepare for and respond to such events.	Azerbaijan acceded in 2004.
International Carriage of Dangerous Goods by Road*.	Provides requirements for the packaging and labelling of dangerous goods and the construction, equipment and operations of transportation vehicles. Annexes provide detailed technical requirements.	Entered into force in Azerbaijan in 2000.
Tehran- Caspian Framework Convention.	Ratified by all five littoral states and entered into force in 2006. Requires member states to take a number of generic measures to control pollution of the Caspian Sea. Four protocols have been drafted which will, when adopted, form the basis for national legislation and regulations.	Convention is ratified, but protocols are at the time of writing still in draft form and do not therefore at present provide a binding basis for the development of legislation.

\* A UNECE agreement; Azerbaijan became a member of the UNECE in 1993. The major aim of the UNECE is to promote pan-European integration through the establishment of norms, standards and conventions.

## 2.4 National Environmental Legislation

The Government has committed to a process to align national environmental legislation with the principles of internationally recognised legislation, based on EU environmental legislation. As this process is on-going, the SD2 Infrastructure Project will comply with the intent of current national legal requirements where those requirements are consistent with the provisions of the PSA, and do not contradict, or are otherwise incompatible with, international petroleum industry standards and practice.

The framework for national environmental legislation in Azerbaijan is provided by the Law on the Protection of the Environment (1999), which addresses the following issues:

- The rights and responsibilities of the State, the citizens, public associations and local authorities;
- The use of natural resources;
- Monitoring, standardisation and certification;
- Economic regulation of environmental protection;
- State Ecological Expertise (SEE);
- Ecological requirements for economic activities;
- Education, scientific research, statistics and information;
- Ecological emergencies and ecological disaster zones;
- Control of environmental protection;
- Ecological auditing;
- Responsibility for the violation of environmental legislation; and
- International cooperation.

According to Article 54.2 of the Law on Protection of the Environment, EIAs are subject to SEE, which means that the environmental authority (MENR) is responsible for the review and approval of EIA reports submitted by developers. The Law establishes the basis for the SEE procedure, which can be seen as a “stand-alone” check of compliance of the proposed Project with the relevant environmental standards (e.g. for pollution levels, discharges and noise). In addition the law determines that projects cannot be implemented without a positive SEE resolution.

The SEE approach requires state authorities to formally verify all submitted developments for their potential environmental impacts. Current internationally recognised practice emphasises a proportionate, consultative and publicly accountable approach to assessing impacts.

Table 2.3 provides a summary of the key national environmental and social laws.

**Table 2.3 Key National Environmental and Social Laws<sup>2</sup>**

Subject	Title	Date	Description / Relevance to SD2 Infrastructure ESIA
General	Law of Azerbaijan Republic on the Protection of the Environment No. 678-IQ.	08/06/1999 (last amendment 30/03/2001)	Establishes the main environmental protection principles and the rights and obligations of the State, public associations and citizens regarding environmental protection (described above).
	Law on Automobile Roads, Section 39: Protection of the Environment.	10/03/2000	Requires that any construction or reconstruction of roads receives official approval from SEE where the project must demonstrate that best practicable techniques are used and all chemicals used during a project must be environmentally sound.
	SNIP 2.05.02-85 Building Code & Regulations for Automobile Roads Ch. 3: Environmental Protection.	1987 revised 2000	Promotes minimising adverse environmental impacts through effective road design, as well as: <ul style="list-style-type: none"> <li>• Providing instructions on the removal and reuse of top soil (no. 3.4);</li> <li>• Establishing the need to provide a buffer between the road and populated areas;</li> <li>• Requiring noise reduction measures such that compliance with relevant noise norms are met (no. 3.9.); and</li> <li>• Setting out the process of dumping excess materials (no. 3.12).</li> </ul>
	Guidelines for Road Construction, Management and Design: Part I: Planning of Automobile Roads. Part II: Construction of Automobile Roads.	07/02/2000	Addresses environmental issues in road design, construction and maintenance. Provides comprehensive provisions on environmental protection measures in road construction such as use of soils; protection of surface and groundwater resources; protection of flora and fauna; use, preparation and storage of road construction machinery and materials; servicing of construction machinery; provisional structures; provisional roads; fire protection; borrow pits and material transport; avoidance of dust; protection of soils from pollution, prevention of soil erosion etc. The appendices to this document also state standards for, maximum permitted concentrations of toxic substances; noise control measures; soil pollution through losses of oil and fuel from construction equipment; and the quality of surface water.
	Law of Azerbaijan Republic on Ecological Safety No. 677-IQ.	08/06/1999	One of two keystone laws of the country's environmental legislation (along with the <i>Law on the Protection of the Environment</i> ). Its purpose is to establish a legal basis for the protection of life and health, society, the environment, including atmospheric air, space, water bodies, mineral resources, natural landscapes, plants and animals from natural and anthropogenic dangers.  The Law assigns the rights and responsibilities of the State, citizens and public associations in ecological safety, including information and liability. The Law also deals with the regulation of economic activity, territorial zoning and the alleviation of the consequences of environmental disasters.
Ecosystems	Law of the Azerbaijan Republic on Specially Protected Natural Territories and Objects No. 840-IQ.	24/03/2000	Determines the legal basis for protected natural areas and objects in Azerbaijan.
	Law of Azerbaijan Republic on Fauna No. 675-IQ.	04/06/1999	Defines the animal world, property rights over fauna and legal relationships between parties. It also describes issues of State inventory and monitoring, and economic and punitive regulations.

<sup>2</sup> This table is compiled from a variety of sources including: United Nations 2004, Environmental Performance Reviews Series No. 19 – Azerbaijan; Currie & Brown, 2008, Integrated Solid Waste Management System for the Absheron Peninsula Project, and Popov 2005, Azerbaijan Urban Environmental Profile (an ADB Publication).

Subject	Title	Date	Description / Relevance to SD2 Infrastructure ESIA
Water	Water Code of Azerbaijan Republic (approved by Law No. 418-IQ).	26/12/1997	Regulates the use of water bodies, sets property rights and covers issues of inventory and monitoring. The Code regulates the use of water bodies for drinking and service water and for medical treatment, spas, recreation and sports, agricultural needs, industrial needs and hydro energy, transport, fishing and hunting, discharge of waste water, fire protection and specially protected water bodies. It provides for zoning, maximum allowable concentrations of harmful substances and basic rules of industry conduct.
	Law of the Azerbaijan Republic on Water Supply and Wastewater No. 723-1Q.	28/10/1999	Applicability limited to onshore operations. Restricts industrial waste releases into the sewage system; requires segregation of stormwater and industrial wastes from sewage, and requires legal entities to acquire permissions to operate sewage treatment plant.
	Rules of Referral of Specially Protected Water Objects to Individual Categories, Cabinet of Ministers Decree No. 77.	01/05/2000	The Caspian Sea is a specially protected water body. This resolution requires special permits for disposal if there are no other options for wastewater discharge. The resolution allows for restrictions to be placed on the use of specially protected water bodies, and for further development of regulations related to these water bodies. It requires consent from MENR for activities that modify the natural conditions of specially protected water bodies, and includes provisions for permitting of any discharges to water that cannot be avoided. There are also special requirements for the protection of water bodies designated for recreational or sports use (which includes the Caspian).
	Rules for Protection of Surface Waters from Waste Water Pollution, State Committee of Ecology Decree No. 1.	04/01/1994	Under this legislation the <i>Permitted Norms of Harmful Impact Upon Water Bodies of Importance to Fisheries</i> require discharges to meet several specified standards for designated water bodies in terms of suspended solids; floating matter; colour, smell and taste; temperature; dissolved oxygen; pH; Biological Oxygen Demand (BOD) and poisonous substances. Limits are based on Soviet era standards and are to be achieved at the boundary of the facility (specific "sanitary protection zone limits") rather than "end-of-pipe" limits. End of pipe limits are defined in facility-specific "eco-passports" and are established with the intent to ensure compliance with applicable ambient standards.
Air	Law of Azerbaijan Republic on Air Protection No. 109-IIQ.	27/03/2001	Establishes the legal basis for the protection of air, thus implementing the constitutional right of the population to live in a healthy environment. It stipulates the rights and obligations of the authorities, legal and physical persons and NGOs in this respect, sets general requirements for air protection during economic activities, establishes norms for mitigating physical and chemical impacts to the atmosphere, establishes rules for the State inventory of harmful emissions and their sources and introduces general categories of breaches of the Law that will trigger punitive measures.
	Methodology to Define Facilities' Hazards Categories Subject to Hazardous Substance Emissions Levels and Need to Develop Projects' Maximum Permissible Emissions (MPEs).	04/09/1990	Under this methodology the maximum permissible concentrations of harmful substances and their hazard classes are provided. Limits are based on Soviet era standards.
Waste	Law of Azerbaijan Republic on Industrial and Domestic Waste No. 514-IQ.	30/06/1998	Describes State policy in environmental protection from industrial and household waste including harmful gases, waste water and radioactive waste. It defines the rights and responsibilities of the State and other entities, sets requirements for the design and construction of waste-treatment installations, licensing of waste generating activities, and for the storage and transport of waste (including transboundary transportation). The Law also encourages the introduction of technologies for the minimisation of waste generation by industrial enterprises. There is a general description of responses to infringements. This law is specified by Resolutions of the Cabinet of Ministers on the rules of certification of hazardous wastes, state strategy on management of hazardous wastes in Azerbaijan and by Instructions on the Inventorisation Rules and Classification System of the Wastes generated by Industrial Processes and In the Field of Services approved by the MENR.

Subject	Title	Date	Description / Relevance to SD2 Infrastructure ESIA
Information	Law of the Azerbaijan Republic on Access to Environmental Information No. 270-IQ.	12/03/2002	Establishes the classification of environmental information. If information is not explicitly classified "for restricted use" then it is available to the public. Procedures for the application of restrictions are described. Law aims to incorporate the provisions of the Aarhus Convention (ratified by Azerbaijan in 1999) into Azeri Law.
Community health & safety	Law on Sanitary-Epidemiological Services (authorised by Presidential Decree No. 371).	10/11/1992	Establishes sanitary and epidemiological requirements for industrial entities to be met at design, construction and operational stages, and for other economic activities. Aims to protect the health of the population. It addresses the rights of citizens to live in a safe environment and to receive full and free information on sanitary-epidemic conditions, the environment and public health.
	Law of the Azerbaijan Republic on Protection of Public Health No. 360-IQ.	26/06/1997	Sets out the basic principles of public health protection and the health care system. The Law assigns liability for harmful impact on public health, stipulating that damage to health that results from a polluted environment shall be compensated by the entity or person that caused the damage.
	Law of the Azerbaijan Republic on Public Radiation Safety No. 423-IQ.	30/12/1997	Includes requirements for ensuring radiation safety in industrial entities. The Law establishes the main principles of government policy on radiation safety, as well as environmental norms protecting the safety of employees and populations in areas potentially affected by the use of radioactive sources. The Law provides for compensation for damage to health, property and life during accidents.
	Rules of Filing and Consideration of Applications for Withdrawal of Plots of Land, Allocation of Plots of Land for State and Public Purposes, Resolution No. 42 on Certain Normative-Legal Acts related to the Land Code of the Azerbaijan Republic.	15/03/2000	Identifies process of applying for withdrawal and allocation of plots of land for state and public purposes, including construction of industrial facilities and pipelines.
	State Standard for Stationary Equipment State Committee of Metrology and Standardisation of USSR as GOST 27409-87- from 1987-07-01.	01/07/1987	Includes noise level limitations for the operation of stationary equipment.
Liability	Law on Azerbaijan Republic on Mandatory Environmental Insurance No. 271.	12/03/2002	Identifies requirements for the mandatory insurance of civil liability for damage caused to life, health, property and the environment resulting from accidental environmental pollution.
Permitting	A System of Standards for the Environment Protection and Improvement of Natural Resources Utilisation. Industrial Enterprise Ecological Certificate Fundamental Regulations, GOST 17.0.0.04-90.	01/07/1990	The MENR issues ecological documents on the impact on the environment of potentially polluting enterprises. The documents include maximum allowable emissions, maximum allowable discharges, and an "ecological passport." The last item is specific to countries of the Former Soviet Union and contains a broad profile of an enterprise's environmental impacts, including resource consumption, waste management, recycling, and the effectiveness of pollution treatment. Enterprises develop the draft passport themselves and send it to MENR for approval.
Cultural heritage	Law on the Protection of Historical and Cultural Monuments.	1998	Specifies the responsibilities of state and local authorities, and lays down principles for the use, study, conservation, restoration, reconstruction, renovation and safety of monuments. The Law declares that cultural objects with national status: historical and cultural monuments, cultural goods stored in state museums, archives, libraries, as well as the territories where they are situated, are not subject to privatisation. Requires archaeological studies prior to construction works in areas with archaeological significance.

## 2.4.1 National EIA Guidance

Guidance on the EIA process in Azerbaijan is provided in the Handbook for the Environmental Impact Assessment Process in Azerbaijan. The handbook introduces the main principles of the 'western'-type EIA process and details:

- The EIA process, i.e. the sequence of events and the roles and responsibilities of applicants and Government institutions;
- The purpose and scope of the EIA document;
- Public participation in the process;
- Environmental review decision (following its submission to the MENR, the ESIA document is reviewed for up to three months by an expert panel); and
- The appeal process.

A summary of the guidance provided in the handbook is given in Table 2.4 below.

The approval of an EIA by the MENR establishes the compliance framework, including the environmental and social standards that an organisation should adhere to.

**Table 2.4 Summary of Guidance on the EIA Process in Azerbaijan<sup>3</sup>**

<b>Screening</b>	The developer is required to submit an Application (containing basic information on the proposal) to MENR to determine whether an EIA is required.
<b>Scoping</b>	Requirement for a Scoping Meeting to be attended by the developer, experts and concerned members of the public, and aimed at reaching a consensus on the scope of the EIA.
<b>Project Description</b>	Full description of technological process and analysis of what is being proposed in terms of planning, pre-feasibility, construction and operation.
<b>Environmental Studies</b>	Requirement to describe fully the baseline environment at the site and elsewhere, if likely to be affected by the proposal. The environment must be described in terms of its various components – physical, ecological and social.
<b>Consideration of Alternatives</b>	No requirement to discuss Project alternatives and their potential impacts (including the so-called "do-nothing" alternative), except for the description of alternative technologies.
<b>Impact Assessment and Mitigation</b>	Requirement to identify all impacts (direct and indirect, onsite and offsite, acute and chronic, one-off and cumulative, transient and irreversible). Each impact must be evaluated according to its significance and severity and mitigation measures provided to avoid, reduce, or compensate for these impacts.
<b>Public Participation</b>	Requirement to inform the affected public about the planned activities twice: when the application is submitted to the MENR for the preliminary assessment and during the EIA process. The developer is expected to involve the affected public in discussions on the proposal.
<b>Monitoring</b>	The developer is responsible for continuous compliance with the conditions of the EIA approval through a monitoring programme. The MENR undertakes inspections of the implementation of activities in order to verify the accuracy and reliability of the developer's monitoring data. The developer is responsible for notifying the MENR and taking necessary measures in case the monitoring reveals inconsistencies with the conditions of the EIA approval.

<sup>3</sup> Source: based on a review of the EIA Handbook and "EIA in the New Oil and Gas Projects in Azerbaijan", Parviz, 2005.

## 2.5 Regional Processes

### 2.5.1 European Union

EU relations with Azerbaijan are governed primarily by the EU-Azerbaijan Partnership and Cooperation Agreement (PCA) and the European Neighbourhood Policy (ENP).

The PCA entered into force in 1999, under Article 43:

*“The Republic of Azerbaijan should endeavour to ensure that its legislation will be gradually made compatible with that of the Community”.*

As part of the PCA an EU assessment of Azerbaijan’s environmental legislation against EU Directives identified a number of recommendations for the approximation of national legislation with EU Directives<sup>4</sup>. Based on this, a draft national programme was developed that emphasises a flexible approach to amending national legislation to take account of institutional capacity and cost<sup>5</sup>.

Following the enlargement of the European Union, the EU launched the ENP and Azerbaijan became part of this policy in 2004. The current National Indicative Programme for implementing the ENP<sup>6</sup> includes a commitment to support legislative reform in the environmental sector, including:

- Approximation of Azerbaijan's environmental legislation and standards with the EU's;
- Strengthening of management capacity through integrated environmental authorisation;
- Improved procedures and structures for environmental impact assessment; and
- Development of sectoral environmental plans (waste and water management, air pollution, etc.).

### 2.5.2 Environment for Europe

Environment for Europe<sup>7</sup> is a partnership of member states, including Azerbaijan, and other organisations within the UNECE region. Under the auspices of the Environment for Europe a series of ministerial conferences on the environment have been held that have resulted in the establishment of the UNECE conventions described in Section 2.4.

## 2.6 International Petroleum Industry Standards and Practices

SD related activities are required to comply with national legislation with respect to public health, safety and protection and restoration of the environment where it is no more stringent than the Environmental Standards (SD PSA Article 26.4). Consideration of relevant international industry standards is therefore an important element in determining the applicability or otherwise of national legislation. Industry standards including those of the Oil Industry International Exploration and Production Forum (E&P Forum), the International Association of Geophysical Contractors (IAGC) and the International Association of Drilling Contractors (IADC) were specifically mentioned in the SD PSA. There are no specific international standards with regard to construction activities within the PSA.

---

<sup>4</sup> Mammadov, A. & Apruzzi, F. (2004) Support for the Implementation of the Partnership Cooperation Agreement between EU-Azerbaijan. Scoreboard Report on Environment and Utilisation of Natural Resources. Report prepared for TACIS.

<sup>5</sup> SOFRECO (undated) Support for the Implementation of the PCA between EU-Azerbaijan, Draft Programme of legal Approximation.

<sup>6</sup> NIP (2007) European Neighbourhood and Partnership Instrument, Azerbaijan National Indicative Programme.

<sup>7</sup> UNECE (2008) Environment for Europe (<http://www.unece.org/env/efe/welcome.html>).



## **2.7 BP Requirements**

The BP Group Defined Practice (GDP) 'Environmental and Social Requirements for New Access Projects, Major Projects, International Protected Area Projects and Acquisition Negotiations' sets out a rigorous, consistent methodology for early identification of potential environmental and social impacts, known as screening. This practice is supported by the BP Group Recommended Practice (GRP) 'Environmental and Social Recommendations for Projects' which provides recommendations that support the management of potential environmental and social impacts from Projects. The GRP contains seven Impact Management Processes (IMPs) and sixteen Performance Recommendations (PRs) which are relevant to the SD2 Infrastructure Project's activities.



### 3 Impact Assessment Methodology

#### Contents

3.1	Introduction.....	2
3.2	ESIA Process .....	2
	3.2.1 Screening and Scoping .....	3
	3.2.2 Project Alternatives and Base Case Design .....	3
	3.2.3 Existing Conditions.....	4
	3.2.4 Impact Significance Assessment .....	4
	3.2.5 Environmental Impacts.....	5
	3.2.6 Socio-Economic Impacts.....	8
3.3	Transboundary and Cumulative Impacts .....	9
3.4	Mitigation and Monitoring .....	10

#### List of Figures

Figure 3.1	The ESIA Process.....	2
------------	-----------------------	---

#### List of Tables

Table 3.1	Event Magnitude Rankings .....	5
Table 3.2	Receptor Sensitivity Rankings .....	7
Table 3.3	Impact Significance .....	7
Table 3.4	Socio-Economic Impact Significance.....	9

### 3.1 Introduction

This Chapter presents a description of the Environmental and Socio-Economic Impact Assessment (ESIA) process adopted for the Shah Deniz 2 (SD2) Infrastructure Project and the methodology used to assess impact significance.

### 3.2 ESIA Process

The ESIA process constitutes a systematic approach to the evaluation of a project and its associated activities throughout the project lifecycle. The process (refer to Figure 3.1) includes:

- Screening and Scoping;
- Project Alternatives and Base Case Design;
- Existing Environmental and Socio-Economic Conditions;
- Impact Significance Assessment;
- Mitigation and Monitoring;
- Residual Impacts; and
- Disclosure and Stakeholder Consultation.

The ESIA also includes stakeholder consultation that identifies the views and opinions of potentially affected people and other interested parties. Stakeholder feedback is used to focus the impact assessment and, where appropriate, influence project design and execution.

**Figure 3.1 The ESIA Process**

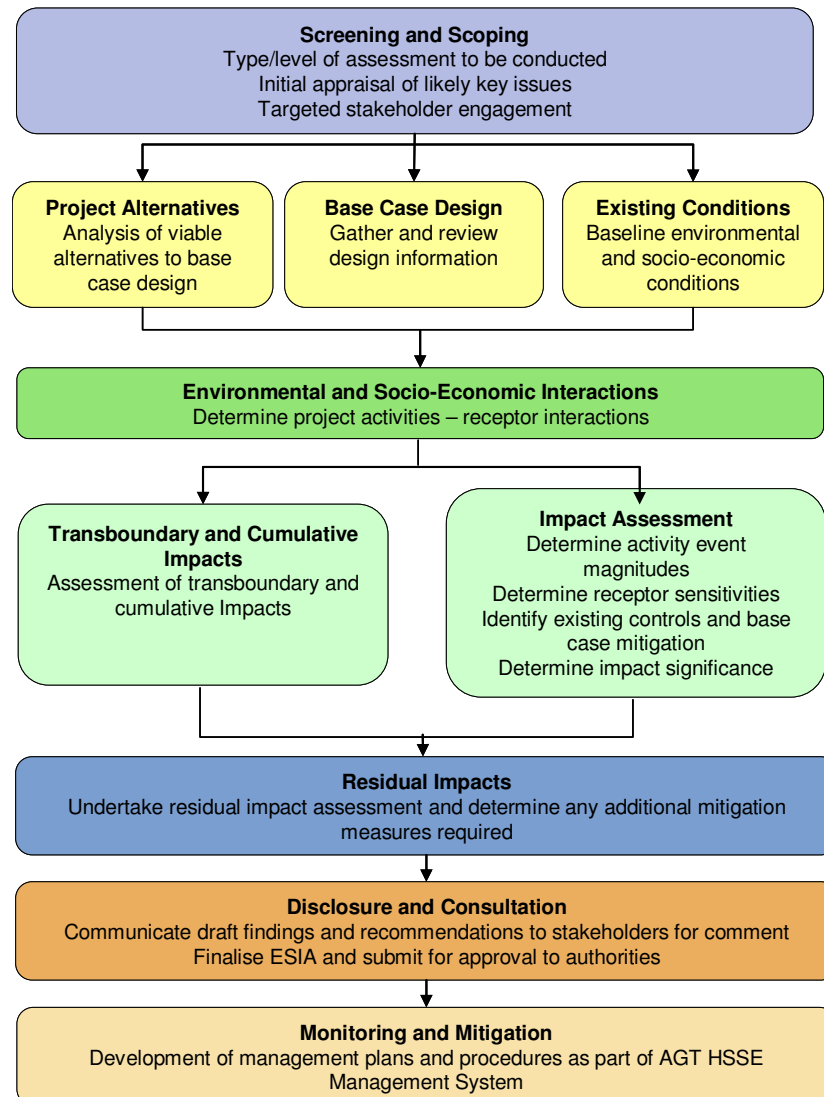

### 3.2.1 Screening and Scoping

Screening is the first step in the assessment process. It confirms the need (or otherwise) for an ESIA by appraising the type of project and its associated activities throughout its lifecycle in the context of its biophysical, socio-economic, policy and regulatory environments.

Given the location, scale and planned activities associated with the SD2 Infrastructure Project, it was agreed with the Ministry of Ecology and Natural Resources (MENR) that the project should be subject to an ESIA, and the ESIA should take account of applicable national and international legislation, SD PSA and BP standards as detailed in Chapter 2: Policy, Regulatory and Administrative Framework.

Scoping is a high level assessment of anticipated “interactions” between project activities and environmental “receptors”. Its purpose is to focus the assessment on key issues and eliminate certain activities from the full impact assessment process based on their limited potential to result in discernable impacts. To arrive at a conclusion to ‘scope out’ an activity/event, a mixture of expert scientific judgement based on prior experience of similar activities and events and, in some instances, scoping level quantification/numerical analysis (e.g. emission and discharge modelling) is used.

The SD2 Infrastructure Project Scoping process has included:

- Review of existing environmental and socio-economic data and reports relevant to the project activities; and
- Liaison with the SD Infrastructure Design Team to gather data and to formulate an understanding of project activities.

Based on the findings and results of these reviews, investigations and consultations, the SD2 Infrastructure Project Team identified:

- Potential project related environmental and socio-economic impacts based on likely interactions between SD2 Infrastructure Project activities and environmental/socio-economic receptors; and
- Gaps where the extent, depth and/or quality of environmental, socio-economic and/or technical data is insufficient for the SD2 Infrastructure ESIA process, thus identifying the additional work required to complete the ESIA.

### 3.2.2 Project Alternatives and Base Case Design

#### 3.2.3.1 Project Alternatives

The initial step in defining a project is to identify, at a conceptual level, viable alternatives to the project so that a Base Case Design may be realised. Consideration of project alternatives occurs at two levels:

- To the development as a whole, including the “no development” option, and
- Engineering alternatives within the selected project’s concept design definition.

Project alternatives were defined during the early conceptual design of the SD2 Infrastructure Project and were compared on financial, technical design, safety, environmental and socio-economic criteria. The alternative that represented the best balance in regards all criteria was taken forward to the subsequent detailed design stage.

Chapter 4: Options Assessed presents a summary of the alternative designs considered and options evaluated for the SD2 Infrastructure Project.

### 3.2.3.2 Project Design

The SD2 Infrastructure ESIA Team worked with the SD2 Infrastructure Design Team to gather and interpret relevant information for the ESIA. This dialogue between the teams identified where additional project design definition, in terms of existing controls and additional mitigation measures, was required in the SD2 Infrastructure Base Case Design to minimise impacts. Opportunities identified for environmental and socio-economic enhancements were considered by the teams and incorporated into the Base Case Design where appropriate and practicable.

The SD2 Infrastructure Base Case Design, on which the SD2 Infrastructure impact assessment is based, is presented in Chapter 5: Project Description.

### 3.2.3 Existing Conditions

In order to identify potential impacts to receptors, an understanding of the existing conditions was established prior to execution of project activities. The SD2 Infrastructure ESIA Scoping exercise determined that the project will likely result in impacts on the following receptor groups:

- Biological/Ecological Receptor;
- Physical Receptor/Feature;
- Soil, Ground Water and Surface Water Quality; and
- Socio-Economic/Human.

A review of existing baseline data, covering a period from 1996 to 2011, and including results of the ongoing Integrated Environmental Monitoring Programme (IEMP), was undertaken to identify the existing conditions within the Terminal vicinity. A number of specific surveys were also undertaken to gather additional environmental data. These included noise, odour, visual context and light surveys. Meteorological and hydrological data was provided by the Baku State University National Hydrometeorological Department and the Institute of Geography at the National Academy of Sciences of the Azerbaijan Republic respectively.

Data associated with existing socio-economic conditions was obtained from secondary data sources including State Statistical data and directly from the Garadagh District Executive Power. A Stakeholder and Socio-Economic Survey (SSES) was commissioned to obtain relevant up to date information to characterise socio economic conditions within the local communities surrounding the Terminal. More details regarding this survey are provided in Chapter 8: Consultation and Disclosure.

Chapter 6: Environmental Description and Chapter 7: Socio-Economic Description describe the existing environments based on a review of existing data, specific environmental surveys undertaken to inform this ESIA and the findings of the SSES.

### 3.2.4 Impact Significance Assessment

An impact, as defined by ISO14001:2004 is: *“Any change to the environment, whether adverse or beneficial, wholly or partially resulting from an organisation’s environmental aspects (activities, products or services)”*.

Where project activity – receptor interactions occur, an impact is defined. The ESIA process ranks impacts according to their “significance” determined by considering project activity “event magnitude” and “receptor sensitivity”. Determining event magnitude requires the identification and quantification (as far as practical) of the sources of potential environmental and social effects from routine and non-routine project activities. Determining receptor environmental sensitivity requires an understanding of the biophysical environment.

The sections below set out the methodology for both environmental and socio-economic impact assessment.

### 3.2.5 Environmental Impacts

#### Method for Determining Event Magnitude

Event magnitude is determined based on the following parameters, which are equally weighted and are each assigned a rating of "1", "2", or "3":

- **Extent / Scale:** Events range from those affecting an area:
  - 1 – Up to 500m from the source or an area less than 50 hectares; to
  - 2 – Greater than 500m and up to 1km from the source or an area between 50-100 hectares; to
  - 3 – Greater than 1km from the source or an area greater than 100 hectares.
  
- **Frequency:** Events range from those occurring:
  - 1 - Once; to
  - 2 - Up to 50 times; to
  - 3 - More than 50 times or continuously.
  
- **Duration:** Events range from those occurring for:
  - 1 – Up to one week; to
  - 2 - More than one week and up to one month; to
  - 3 - Periods longer than one month to permanent.
  
- **Intensity:** Concentration of an emission or discharge or noise level with respect to standards of acceptability that include applicable legislation and international guidance. Degree/permanence of disturbance or physical impact (e.g. disturbance to species, loss of habitat or damage to cultural heritage). Ranges from:
  - 1 - A low intensity event; to
  - 2 - A moderate intensity event; to
  - 3 - A high intensity event.

Overall event magnitude is then scored on a spectrum from low (1) to high (12) by adding the individual parameter scores:



Resulting individual ratings are summed to give the overall event magnitude ranking. Table 3.1 presents the score ranges for magnitude rankings of "Low", "Medium" and "High".

**Table 3.1 Event Magnitude Rankings**

Event Magnitude	Score (Summed Parameter Rankings)
Low	4
Medium	5-8
High	9-12

## Method for Determining Receptor Sensitivity

Receptor sensitivity is determined based on the following parameters, which are equally weighted and are each assigned a rating of "1", "2", or "3":

- **Biological/Ecological Receptors:**

- **Presence:** Ranges from:

- 3 - Routine, regular or reliably predictable presence of any species which is, in reverse order, a unique, threatened or protected species; to

- 2 - Regionally rare or largely confined to the SD2 Infrastructure area or sensitive to industry emissions /disturbances; to

- 1 - A species which is none of the above and is therefore assessed at the community level only.

- **Resilience (to the identified stressor):** Ranges from:

- 1 - Species or community unaffected or marginally affected; to

- 2 - Species undergoing moderate but sustainable change which stabilises under constant presence of impact source, with ecological functionality maintained; to

- 3 - Substantial loss of ecological functionality (e.g. loss of species in key groups, substantially lower abundance and diversity).

- **Human Receptor:**

- **Presence:** Ranges from:

- 3 - People being permanently present (e.g. residential property) in the geographical area of anticipated impact; to

- 2 - People being present some of the time (e.g. commercial property); to

- 1 - People being uncommon in the geographical area of anticipated impact.

- **Resilience (to the identified stressor):** Ranges from:

- 1 - People being least vulnerable to change or disturbance (i.e. ambient conditions (air quality, noise) are well below applicable legislation and international guidance); to

- 2 - People being vulnerable to change or disturbance (i.e. ambient conditions (air quality, noise) are below adopted standards); to

- 3 - Most vulnerable groups (i.e. ambient conditions (air quality, noise) are at or above adopted standards).

- **Physical Receptor/Feature:**

- **Presence (to the identified stressor):** Ranges from:

- 3 - Presence of feature any species which has, in reverse order, national or international value (e.g. state protected monument); to

- 2 – Feature with local or regional value and is sensitive to disturbance; to

- 1 - Feature which is none of the above.

- **Resilience (to the identified stressor):** Ranges from:

- 1 – Feature/receptor is unaffected or marginally affected i.e. resilient to change;

- 2 – Undergoes moderate but sustainable change which stabilises under constant presence of impact source, with physical integrity maintained; and

- 3 – Highly vulnerable i.e. potential for substantial damage or loss of physical integrity.



- **Soil, Ground Water and Surface Water**

- **Presence:** Ranges from:

- 3 – Receptor is highly valued e.g. used extensively for agriculture, used as a public water supply; to
- 2 – Receptor has moderate value e.g. moderate/occasional use for agriculture purposes; to
- 1 – Receptor has limited or no value.

- **Resilience (to the identified stressor):** Ranges from:

- 1 – No or low levels of existing contamination (well below accepted standards) and receptor is unaffected or marginally affected i.e. resilient to change; to
- 2 – Moderate levels of mobile contamination present which are vulnerable to physical disturbance; to
- 3 – High levels of mobile contamination present which are highly sensitive to physical disturbance.

Overall receptor sensitivity is then scored on a spectrum from low (1) to high (6) by adding the individual parameter scores:



Table 3.2 presents the score ranges for sensitivity rankings of "Low", "Medium" and "High".

**Table 3.2 Receptor Sensitivity Rankings**

Receptor Sensitivity	Score (Summed Parameter Rankings)
Low	2
Medium	3-4
High	5-6

**Method for Determining Environmental Impact Significance**

Impact significance, as a function of event magnitude and receptor sensitivity is subsequently ranked as "Negligible", "Minor", "Moderate" or "Major" as presented in Table 3.3 below. Impacts can be "positive" or "negative".

**Table 3.3 Impact Significance**

		Receptor Sensitivity		
		Low	Medium	High
Event Magnitude	Low	Negligible	Minor	Moderate
	Medium	Minor	Moderate	Major
	High	Moderate	Major	Major

Any impact classified as "Major" is considered to be significant and where the impact is negative, requires additional mitigation. Impacts of negligible, minor or moderate significance are considered as being mitigated as far as practicable and necessary, and therefore, do not require further mitigation.

### 3.2.6 Socio-Economic Impacts

The socio-economic impact assessment identifies and evaluates the significance of impacts associated with the SD2 Infrastructure Project, including:

- The identification of all socio-economic impacts (direct and indirect, positive and negative) that are linked to the SD2 Infrastructure Project.
- The measurement (and where possible, monetisation) of socio-economic impacts, including the following:
  - The numbers and characteristics of people affected (number of property owners, affected people and/or those subjected directly to changes in their socio-economic conditions and living environment);
  - Changes in people's access to, or changes in the status of: employment, commercial, recreational, cultural and social services and facilities;
  - Direct loss of land, or change in people's access to land;
  - Social patterns and linkages: changes in how areas function as a community with respect to levels of social interaction; personal relationships; feeling of belonging to the area or aspects relating to self-identification; and
  - General amenity (perceived and actual) and change in the physical conditions that affect the quality of the environment and residential amenity; change in aesthetic values; change in recreation development and opportunities.

The socio-economic impact assessment assesses the significance of potential direct impacts based on probability, magnitude and receptor sensitivity.

- **Probability:** The likelihood that the impact will occur, and degrees of uncertainty, based on the following criteria:
  - **Highly likely** - almost certain to occur or may have already occurred.
  - **Likely** - some substantiated evidence that the impact is likely to occur, or has previously occurred in a similar context.
  - **Possible** - could occur without intervention.
  - **Unlikely** - some evidence that impact could occur, no such incident in the region but may have occurred elsewhere.
  - **Highly unlikely** - no evidence to suggest impact will occur.
- **Magnitude:** Determined based on:
  - **Spatial Scope:** The geographical scope of the impact relative to local community receptors:
    - **Local** – effects extending to the communities in the immediate Terminal vicinity (i.e. Sangachal town, Umid, Azim Kend and Masiv 3);
    - **Regional** – effects extending to the Garadagh District; and
    - **National** - effects extending to Azerbaijan.
  - **Timing and Duration:** The likely timing and duration of the impact (including whether the impact would be temporary or permanent in nature) and how this links to activities undertaken by the SD2 Infrastructure Project;
- **Receptor Sensitivity:** The groups of people or populations most likely to be affected and, in particular, whether impacts are likely to be disproportionately experienced by **vulnerable groups**.

Significance of impacts will be assessed as presented in Table 3.4.

**Table 3.4 Socio-economic Impact Significance**

Event	Magnitude		Probability	Receptor Sensitivity	Significance
	Spatial Scope	Timing and Duration			

Significance is based on judgement taking into account the likelihood and magnitude of the impact and the sensitivity of the population or group of people that may be affected. The significance of impact (taking into account existing controls) is categorised as follows:

- **Major Positive** – a substantial positive change.
- **Positive** - some positive change.
- **Negligible** - very little change or no change.
- **Negative** - measurable negative change.
- **Major Negative** - considerable negative change.

Any impact classified as “Major Negative” is considered to be significant and requires additional mitigation. Impacts of “Negligible”, “Major Positive” or “Positive” significance are not considered to require mitigation.

Indirect impacts i.e. induced effects, cannot be readily assessed using the same approach. A qualitative assessment is therefore made based on judgement and taking into account existing controls.

### 3.3 Transboundary and Cumulative Impacts

Transboundary impacts are impacts that occur outside the jurisdictional borders of a project’s host country. Potential SD2 Infrastructure Project transboundary impacts are considered to include:

- Social and economic issues surrounding the sourcing of labour, goods and services from the international market; and
- GHG emissions to air.

Cumulative impacts arise from:

- Interactions between separate project-related residual impacts; and
- Interactions between project-related residual impacts in combination with impacts from other projects and their associated activities.

These can be either additive or synergistic effects, which result in a larger (in terms of extent or duration) or different (dependent on impact interaction) impacts when compared to project-related residual impacts alone.

The cumulative assessment presented in Chapter 11: Cumulative and Transboundary Impacts and Accidental Events, initially considers the potential for impact interaction and accumulation in terms of the following:

- **Temporal Overlap** – the impacts are so close in time that the effect of one is not dissipated before the next one occurs;
- **Spatial Overlap** – the impacts are so close in space that their effects overlap.

At the time of writing the following new projects are proposed or are under construction in the vicinity of the Sangachal Terminal:

- Qizildas Cement Plant – new 5,000 tonne capacity cement plant (approximately 4km to the north);
- Garadagh Dry Kiln Project – works to upgrade at the existing Garadagh cement works to install dry kiln technology (approximately 6km to the east); and
- New Highway Junction – immediately to the south of the Terminal and planned to connect to the new Terminal access road, which forms part of the SD2 Infrastructure works.

In addition it is understood that, a result of an expected significant increase in traffic flows due to industrial development to the north (towards Sahil) and to the south (at Alyat), it is planned to expand the Baku-Salyan Highway along its length to 4 lanes in each direction.

Where there is potential for impact interaction, the project is sufficiently defined and sufficient data is available, a quantitative assessment is undertaken. Where insufficient data is available a qualitative assessment is presented (refer to Chapter 11).

### **3.4 Mitigation and Monitoring**

The iterative and integrated nature of the ESIA and project planning processes means that the majority of proposed additional mitigation measures and strategies have been incorporated into the project Base Case (as provided within Chapter 5: Project Description). These measures / strategies have included mitigation measures and ongoing commitments as previously adopted by other ACG & SD projects and which are of relevance to SD2 Infrastructure Project. These include monitoring and reporting commitments, for, for example, emissions and discharges, as well as policies and procedures that form part of the AGT Environmental Management System.

## 4 Options Assessed

### Contents

4.1	Introduction.....	2
4.1.1	Determination of Project Scope .....	2
4.1.2	Route Options Assessment .....	4
4.1.3	Construction Camp and Facilities Locations.....	9
4.1.4	Pipeline Landfall Area .....	9
4.1.5	Drainage Management and Flood Protection .....	10

### List of Figures

Figure 4.1	Key Constraints.....	3
Figure 4.2	Access Road Route Options.....	5

### List of Tables

Table 4.1	Existing Physical, Environmental and Safety Constraints .....	3
Table 4.2	Description of the Route Groups.....	4
Table 4.3	Route Option Assessment .....	6

## 4.1 Introduction

The purpose of the Shah Deniz 2 (SD2) Project is to further exploit the gas and condensate reserves within the offshore SD Contract Area. The existing Shah Deniz Stage 1 (SD1) processing facilities at the Sangachal Terminal do not have the capacity to accommodate the additional production from the SD2 Project. Therefore, new onshore facilities for the SD2 Project are required.

It was decided to locate the new onshore SD2 facilities next to the existing Terminal. A review of the adjacent areas indicated that a location to the west of the Terminal was the most suitable.

The SD2 Infrastructure Project comprises the works needed prior to the construction of the new SD2 Project onshore facilities. This Chapter discusses the decision making process regarding the location and design of the following key aspects:

- New Terminal access road;
- Construction camp and construction facilities; and
- Drainage and flood protection design measures.

The Chapter presents a summary of the key decisions made during the SD2 Infrastructure Project design stages and the options assessed specifically taking into account environmental and socio-economic issues.

### 4.1.1 Determination of Project Scope

The works required prior to the construction of the SD2 onshore facilities within the SD2 Expansion Area form the scope of the SD2 Infrastructure Project. The project elements were determined based on the following key requirements:

- Establish an access route from the Baku-Salyan Highway for SD2 Project construction traffic and future operations traffic. The route should allow:
  - Separation between existing Terminal operations and construction traffic as far as practical; and
  - Construction traffic to have direct access to/from the highway.
- Establish construction camp (to accommodate up to 600 people), construction facilities (e.g. workshops, laydown areas etc.) and associated utilities for the main SD2 Project works;
- Complete works to prepare the SD2 Expansion Area including clearance and terracing;
- Establish the drainage/flood protection measures to be incorporated into the design; and
- Complete works to prepare the pipeline landfall area for the new SD2 subsea export pipelines from the offshore SD2 facilities.

The potential locations of the project elements were informed by physical, environmental and safety constraints (refer to Table 4.1). Figure 4.1 shows the location of the key physical, environmental and safety constraints taken into account.

**Table 4.1 Existing Physical, Environmental and Safety Constraints**

Aspect	Constraint/Requirement
Existing settlements including: <ul style="list-style-type: none"> <li>Sangachal;</li> <li>Umid; and</li> <li>Azim Kend/ Masiv 3.</li> </ul>	<ul style="list-style-type: none"> <li>Minimise adverse environmental and socio-economic impacts to the local community e.g. noise, air quality, disruption to local community routes and land use.</li> <li>Maximise potential community benefits.</li> </ul>
Baku-Salyan Highway.	<ul style="list-style-type: none"> <li>Minimise disruption to existing road users.</li> <li>Minimise potential for community safety issues associated with traffic.</li> </ul>
Railway.	<ul style="list-style-type: none"> <li>Minimise disruption to railway operations.</li> <li>No permanent at-grade rail crossings.</li> </ul>
Caravanserai <sup>1</sup> .	<ul style="list-style-type: none"> <li>Minimise potential impacts to structure which is listed as a State protected monument.</li> <li>Observe no work zone of 50m around structure.</li> </ul>
Pipelines (including ACG and SD Pipeline Corridor, 3 <sup>rd</sup> party Pipeline Corridor and Export Pipelines).	<ul style="list-style-type: none"> <li>Ensure potential for physical impact to pipelines is minimised during construction works.</li> </ul>
Existing utilities including power lines.	<ul style="list-style-type: none"> <li>Minimise potential diversions and associated disruption to users.</li> <li>Comply with safety zoning requirements associated with structures and roads adjacent to power lines.</li> </ul>
Existing Terminal.	<ul style="list-style-type: none"> <li>Minimise any disruption to existing operations at the Terminal.</li> </ul>
Safety Zoning.	<ul style="list-style-type: none"> <li>Comply with all relevant safety zoning requirements associated with permitted distances for development (buildings and roads) near to: <ul style="list-style-type: none"> <li>Existing gas and oil pipelines;</li> <li>Existing export pipelines (including BTC and SCP); and</li> <li>Future SCP expansion pipeline route.</li> </ul> </li> </ul>
Flare Zones.	<ul style="list-style-type: none"> <li>No facilities to be located within existing ACG/SD or future SD2 flare zones.</li> </ul>
Notes:	
1. 15 <sup>th</sup> Century monument – refer to Chapter 6 Section 6.6 for further detail.	

**Figure 4.1 Key Constraints**

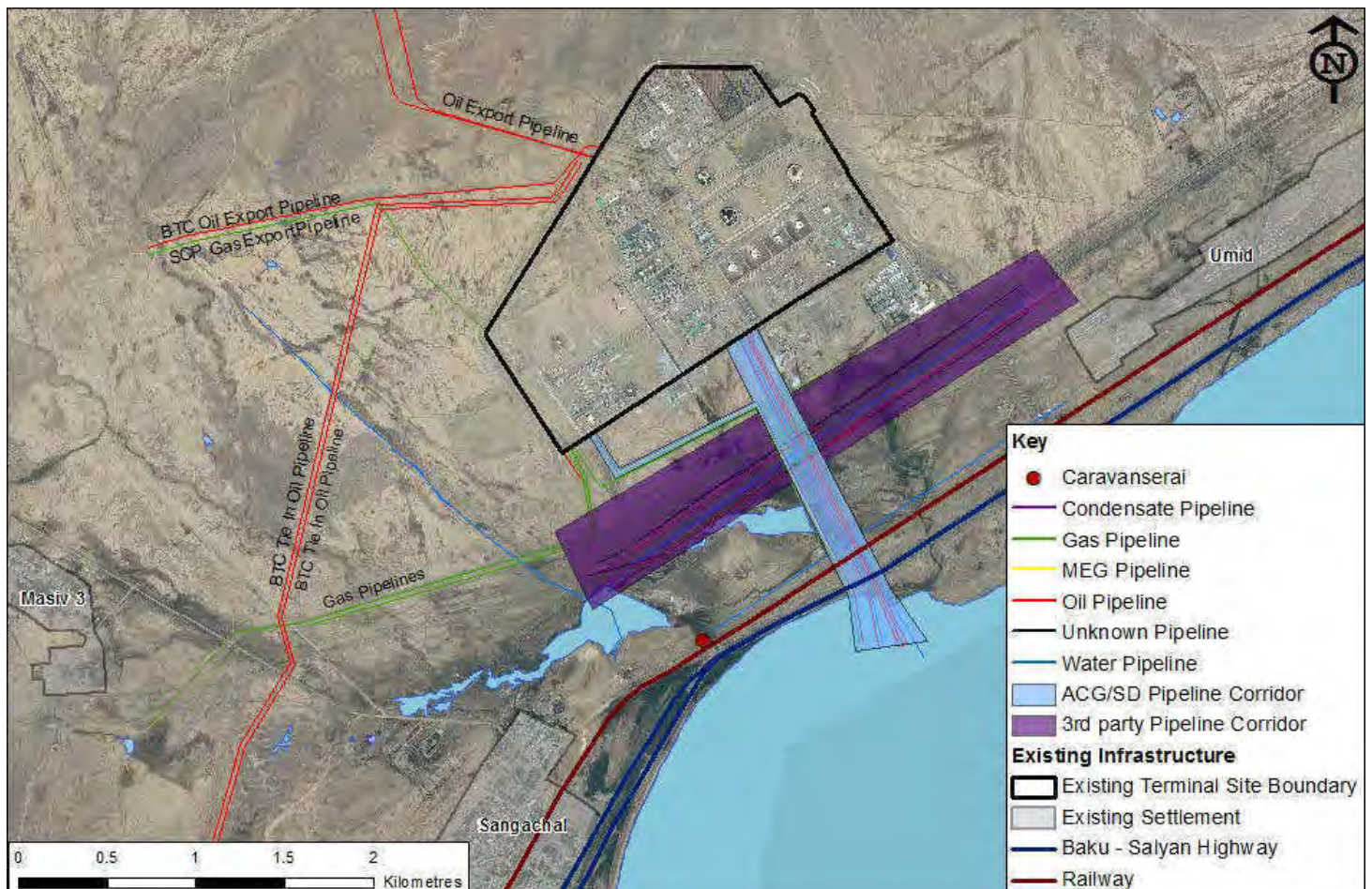



## 4.1.2 Route Options Assessment

The first stage of the options assessment was to consider potential access road routes and then, based on these routes, the location of the construction camp and facilities.

### Access Road

The access road options assessment has been undertaken over two phases between 2008 and 2010:

- **Early Review** – During 2008 and 2009 BP Engineers completed an initial review which focused on eight early road options; and
- **Route Option Assessment** – Following the appointment of the infrastructure design contractor, an initial assessment was undertaken which looked at 26 route options, categorised into 6 coloured groups. Further assessments were then undertaken to refine the shortlisted route options.

### Baku-Salyan Highway Junction

It had not been confirmed at the time of the assessments that the Baku Salyan Highway Junction would be designed and constructed by the Azerbaijan Highways Authority. A conceptual junction design was incorporated within the consideration of each of the route options to ensure that the selected access road route design remained technically feasible.

### Route Option Assessment

A description of the general characteristics of each colour group assessed is provided in Table 4.2 and illustrated in Figure 4.2.

**Table 4.2 Description of the Route Groups**

Route Group	Description of Route Characteristics
Red	From the Baku-Salyan Highway, routes pass through Sangachal Town, crossing the Shachkaiya Wadi before passing to the west of the Terminal.
Brown	From the Baku-Salyan Highway, routes pass between the Sangachal Power Station and the existing ACG/SD pipeline corridor.
Blue	Routes pass from the Baku-Salyan Highway directly to the south of the Terminal, perpendicular to the existing ACG/SD pipeline corridor.
Green	Routes utilising the existing Terminal access road and junction facilities.
Purple	Routes via the Garadagh Road to the east of the Terminal, which pass adjacent and parallel to the railway line before reaching the SD2 Expansion Area.
Yellow	Routes via the Garadagh Road, which follow the same routing as the purple routes but pass north of the Terminal to reach the SD2 Expansion Area from the north.



**Figure 4.2 Access Road Route Options**

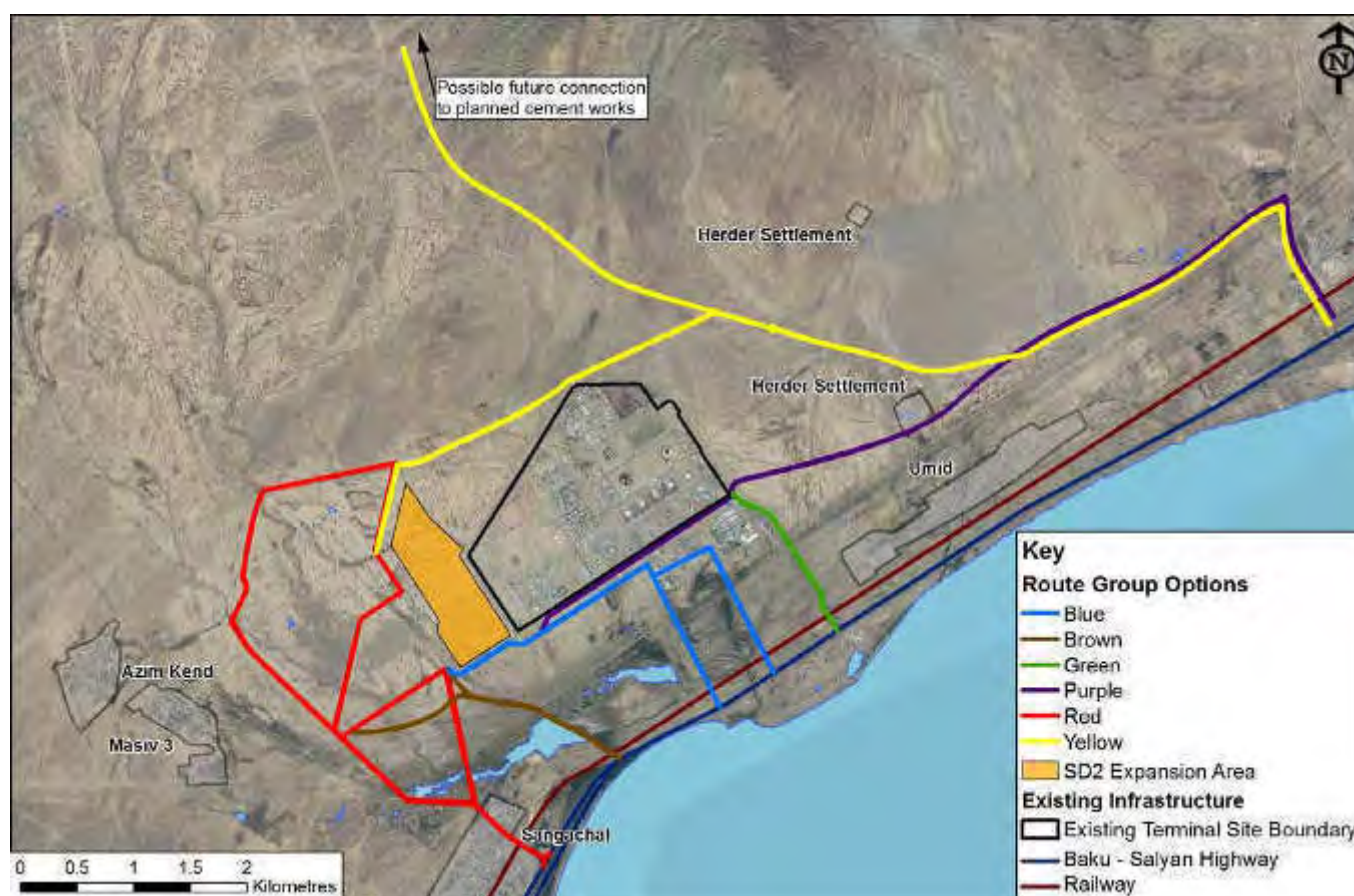

The key criteria used to assess the routes included:

- Environmental and socio-economic impacts on local communities and 3<sup>rd</sup> parties;
- Access to and from the Baku-Salyan Highway (including the requirement for new permanent access to the Terminal);
- Elimination of an at-grade rail crossing;
- Separation of construction and operational traffic;
- Health and safety;
- Security;
- Constructability; and
- Technical Feasibility.

A summary of the assessments undertaken is presented in Table 4.3. In each case the route group was either:

- Eliminated after Early Review & Route Option Screening; or
- Selected for masterplanning i.e. a process of further development and consideration, including additional consultation with the operational stakeholders at the Terminal.

**Table 4.3 Route Option Assessment**

Route Group	Advantages	Disadvantages	Overall Assessment	Eliminated after Early Review & Route Option Screening	Selected for Masterplanning
Red	<ul style="list-style-type: none"> <li>Shorter than other options and no complicated design features.</li> <li>Avoids ACG/SD and 3<sup>rd</sup> party pipeline corridors.</li> <li>Makes use of the existing highways junction and road through Sangachal Town.</li> </ul>	<ul style="list-style-type: none"> <li>Environmental and socio-economic impacts.</li> <li>Does not eliminate an at-grade rail crossing.</li> </ul>	<ul style="list-style-type: none"> <li>Technically feasible.</li> <li>Meets requirement to minimise number of railway crossings but does not eliminate crossing.</li> <li>Meets safety requirements.</li> <li>Potential significant adverse environmental and socio economic impacts associated with:                             <ul style="list-style-type: none"> <li>Land acquisition to widen road through Sangachal Town.</li> <li>Potential resettlement of residents/businesses.</li> <li>Short to medium duration impacts to residents associated with construction phase traffic (e.g. noise, dust, nuisance).</li> </ul> </li> </ul>	✓	
Brown	<ul style="list-style-type: none"> <li>Most direct access from main highway to SD2 construction area.</li> <li>Ability to incorporate improved flood management.</li> <li>Acceptable to State Security.</li> <li>Avoids ACG/SD pipeline corridor.</li> <li>Complete segregation from Operations traffic.</li> </ul>	<ul style="list-style-type: none"> <li>Not centrally located to the Terminal.</li> <li>More complex bridge and access road configuration than other routes.</li> <li>Junction potentially encroaches on edge of Caspian Sea.</li> <li>Route close to Caravanserai (but outside 50m exclusion zone).</li> </ul>	<ul style="list-style-type: none"> <li>Technically feasible.</li> <li>Meets railway regulation requirements.</li> <li>Meets safety requirements.</li> <li>Meets requirement for dedicated access road for SD2 construction vehicles.</li> <li>Minimal adverse socio economic and environmental impacts.</li> </ul>		✓
Blue	<ul style="list-style-type: none"> <li>Centrally located access to the Terminal.</li> <li>Acceptable for State Security.</li> <li>Footprint of route is within land currently owned / used by the Terminal.</li> <li>Eliminates the need for a rail crossing.</li> </ul>	<ul style="list-style-type: none"> <li>Conflict with routes of existing and future pipelines.</li> <li>Located within wetland in front of the Terminal, making construction technically difficult.</li> </ul>	<ul style="list-style-type: none"> <li>Meets railway regulation requirements.</li> <li>Meets safety requirements.</li> <li>Some options meet requirement for dedicated access road for SD2 construction vehicles.</li> <li>Minimal adverse socio economic and environmental impacts.</li> <li>Deemed not technically feasible after masterplanning phase because of land required for incoming SD2 and future pipeline corridors.</li> </ul>		✓

Route Group	Advantages	Disadvantages	Overall Assessment	Eliminated after Early Review & Route Option Screening	Selected for Masterplanning
Green	<ul style="list-style-type: none"> <li>Utilises existing access road.</li> <li>Limited requirement for land acquisition.</li> <li>Most cost effective route.</li> <li>Shortest construction period.</li> <li>Allows use of existing construction camp/facilities at the Terminal.</li> </ul>	<ul style="list-style-type: none"> <li>Does not provide new future Terminal entrance.</li> <li>Increased congestion at existing security post expected.</li> <li>Increased traffic hold up at rail crossing due to increased construction traffic.</li> <li>Potential high congestion between existing work camp and operations offices resulting from Traffic Segregation and Security Monitoring.</li> <li>Disruption to road users on highway likely.</li> <li>Existing project offices and construction facilities will require upgrade – uncertainty on condition of existing facilities.</li> </ul>	<ul style="list-style-type: none"> <li>Technically feasible.</li> <li>Meets railway regulation requirements.</li> <li>Meets safety requirements.</li> <li>Does not meet requirement for dedicated access road for SD2 construction vehicles.</li> <li>Does not meet requirement to minimise traffic disruption.</li> </ul>		✓
Purple	<ul style="list-style-type: none"> <li>Makes use of existing highway junction.</li> <li>No pipeline crossing required.</li> </ul>	<ul style="list-style-type: none"> <li>Does not provide future permanent entrance for the Terminal.</li> <li>Traffic approach from west has extended journey.</li> <li>Community/settlement impacts.</li> <li>Existing State Highway Bridges will require repair / upgrade.</li> <li>Strong reservations from State Security</li> </ul>	<ul style="list-style-type: none"> <li>Technically feasible.</li> <li>Meets safety requirements.</li> <li>Potential significant adverse environmental and socio economic impacts associated with:                             <ul style="list-style-type: none"> <li>land acquisition to widen road near Umid settlement.</li> <li>potential resettlement of residents/businesses.</li> <li>short-medium duration impacts to settlement associated with construction phase traffic (e.g. noise, dust, nuisance).</li> </ul> </li> </ul>	✓	

Route Group	Advantages	Disadvantages	Overall Assessment	Eliminated after Early Review & Route Option Screening	Selected for Masterplanning
Yellow	<ul style="list-style-type: none"> <li>Makes use of existing highway junction.</li> <li>No pipeline crossing required.</li> </ul>	<ul style="list-style-type: none"> <li>Does not provide future permanent entrance for the Terminal.</li> <li>Requires upgrade to four lanes to accommodate safe transit of Sangachal Terminal traffic.</li> <li>Significant land acquisition requirement.</li> <li>Traffic approach from west has potential 12km additional journey.</li> <li>Community / settlement impacts.</li> <li>Existing State Highway Bridges will require repair / upgrade.</li> <li>Strong reservations from State Security.</li> </ul>	<ul style="list-style-type: none"> <li>Technically feasible.</li> <li>Meets safety requirements.</li> <li>Potential significant adverse environmental and socio economic impacts associated with:                             <ul style="list-style-type: none"> <li>land acquisition to widen road near Umid settlement.</li> <li>potential resettlement of residents/businesses.</li> <li>short-medium duration impacts to settlement associated with construction phase traffic (e.g. noise, dust, nuisance).</li> </ul> </li> </ul>	<p style="text-align: center;">✓</p>	

As a result of the assessment summarised in Table 4.3 above, three of the access route groups (Brown, Blue and Green) were taken forward to masterplanning. On the basis of technical feasibility and as a result of the consultation with the relevant stakeholders, it was determined that the brown route group was the most suitable road access option.

The brown route was subsequently developed further as the layout of the elements discussed in the sections below became more defined and as additional information became available with regard to location of pipelines and power lines. The measures incorporated into the road design to mitigate for potential accidental events associated with pipelines are discussed in Chapter 11 Section 11.4. The work undertaken to incorporate drainage management and flood protection measures into the road design are discussed in Section 4.1.5 below.

### 4.1.3 Construction Camp and Facilities Locations

Construction camp and construction facilities locations were assessed in parallel with the access road routes. Seven potential construction camp and construction facilities locations were considered by the SD2 Infrastructure Design Team in areas to the east, west and north of the Terminal and offsite. The initial stage of the assessment was to consider the advantages and disadvantages of each location against pre-determined aspects e.g. environmental impacts (noise, dust and light emissions), technical feasibility, accessibility and security.

Based on the initial assessment it was determined that the following options associated with the construction camp and construction facilities should be rejected:

- **Off-site locations** – Due to security requirements of an off-site location and need for daily transportation of workers to site;
- **Locations east of the Terminal** – Infeasible following the rejection of the Yellow and Purple route groups;
- **Locations north of the Terminal** – Due to existing restrictions in the area (e.g. topography and security) and a preference to avoid adopting an access road route which passes over the BTC, SCP and other oil export pipelines to a location to the north; and
- **Locations west of the Shachkaiya Wadi** – Infeasible as the area lies within a flood plain and the site would be at risk from flooding.

Following the selection of the Brown route group, it was determined that the construction camp and construction facilities should be located adjacent to the SD2 Expansion Area, with the layout of the area informed by the relevant safety zone requirement (refer to Table 4.1).

To provide a degree of separation between the accommodation and workshops, with workers welfare in consideration, it was decided to segregate the construction camp (including accommodation, recreational, canteen and other support facilities) and the construction facilities (including offices, workforce and materials areas). Within the final design the construction camp and construction facilities are located to the north and south of the SD2 Infrastructure area respectively (see Chapter 5 Figure 5.10 for conceptual layouts).

### 4.1.4 Pipeline Landfall Area

The location of the Pipeline Landfall Area has been determined as part of a separate study considering the routing of the SD2 Export Pipelines both offshore and onshore. The routing options considered will be discussed within the SD2 Project ESIA.

#### 4.1.5 Hydrological Modelling During Design Development

Extensive hydrological modelling and assessment, by Water Resources Associates (WRA), has been undertaken to inform the SD2 Infrastructure Project design. The work was supported with:

- Meteorological data from the Baku State University National Hydrometeorological Department; and
- Hydrology information from the Institute of Geography of the National Academy of Sciences of the Azerbaijan Republic.

An initial study completed in 2008 comprised:

- An assessment of the flood run-off from hills and slopes to the west and northwest of the new facilities;
- Validation of the capacity of existing southern flood protection channel and consideration of whether this channel could be narrowed;
- Assessment of the internal drainage issues within the SD2 Infrastructure Area;
- Assessment of how outflows from the existing northern, southern and new western flood protection channels plus internal Terminal drainage outflows can be effectively routed across the 3<sup>rd</sup> party pipeline corridor;
- Understanding of current flood problems posed by the 3<sup>rd</sup> party pipeline corridor; and
- Identification of further hydrological modelling studies to assist in determining potential routes for new access roads, height of new roads and the design of any culverts or bridges.

Using the results of the initial modelling, further hydrological modelling was undertaken in 2010 and 2011 to inform the design. The results (described in full within Appendix 9E) were used to:

- Determine the requirement, location and dimensions for a flood protection berm (to be located to the west of the SD2 Infrastructure Area between the Shachkaiya Wadi and the existing Terminal);
- Determine the channel and associated culvert dimensions (including locations) associated with the new drainage channels within the SD2 Infrastructure area; and
- Inform the design of the new access road including the:
  - Embankment height;
  - Culvert positions and dimensions; and
  - Role of the access road embankment in redirecting flood flows.

The modelling undertaken to determine the existing flow conditions and flood risk is discussed in Chapter 6 Section 6.4.2. The results of the assessment showed that current flood waters flow through the Western and Central drainage channels via storage areas, under the highway and into the Caspian Sea. Hydrological modelling indicated that a major flood event may result in:

- Flooding of the railway in the vicinity of the railway bridge under which the Central drainage channel passes; and
- Flooding of the highway in the vicinity of the highway bridge under which the Western drainage channel passes.

To minimise the impact of flood risk to the railway, it was decided that the embankment associated with the access road should act as a barrier, preventing the majority of flow from the Shachkaiya Wadi to the low lying Central flood storage area. To ensure that during a major flood event the Western flood storage area does not over fill, it was decided that some flow would be permitted to the Central flood storage area, through the culverts under the access road, which are included in the design to enable the access road to cross the 3<sup>rd</sup> party pipelines. The dimensions of the culverts and the associated small levee, designed to

regulate flow under the access road, were informed by hydrological modelling. The location of the culverts and levee are shown in Chapter 5 Figure 5.8.

Design measures to minimise flood risk to the highway where the Western drainage channel passes under the highway were not incorporated into the design as a new highway junction (to be designed and constructed by the State Highways Authority) is proposed in this location. The junction is planned to be elevated and will provide an alternative route should infrequent major flooding of the highway occur in this location.





## 5 Project Description

### Contents

5.1	Introduction.....	2
5.2	Development Areas and Land Acquisition .....	4
5.3	Logistics and Material Supply .....	4
5.4	Project Schedule .....	5
5.5	Project Phases .....	6
5.5.1	Phase 1 – Set Up of Initial Site Compound .....	6
5.5.2	Phase 2 – Establishment of the Enabling Road and Power Diversion Works.....	7
5.5.3	Phase 3 – Site Preparation .....	8
5.5.4	Phase 4 – Main Civils Works .....	12
5.5.5	Phase 5 – Earthworks Profiling.....	14
5.5.6	Phase 6 – Completion and Fit Out of Construction Camp and Construction Facilities .....	15
5.5.7	Phase 7 – Closure of Enabling Road and at-Grade Rail Crossings.....	17
5.6	Construction Materials.....	18
5.7	Construction Plant/Vehicles/Equipment.....	19
5.7.1	Numbers of Onsite Plant/Equipment/Vehicles.....	19
5.7.2	Numbers of Offsite Vehicles and Routing.....	20
5.8	Emissions, Discharges and Waste.....	20
5.8.1	SD2 Infrastructure Project Emissions .....	20
5.8.2	SD2 Infrastructure Project Discharges .....	20
5.8.3	SD2 Infrastructure Project Hazardous and Non Hazardous Waste .....	21
5.9	Training and Employment .....	22
5.10	Working Hours and Night-time Working.....	22
5.11	Management of Change Process.....	22

### List of Figures

Figure 5.1	Overview of SD2 Infrastructure Project .....	3
Figure 5.2	Maximum Extent of Acquisition and Current Terminal Property Boundary .....	4
Figure 5.3	Import Routes to Azerbaijan .....	5
Figure 5.4	Indicative SD2 Infrastructure Project Schedule .....	5
Figure 5.5	Phase 2 - Enabling Road .....	8
Figure 5.6	Phase 3 – Site Preparation .....	9
Figure 5.7	Typical Flood Protection Berm Cross Section .....	10
Figure 5.8	Drainage Channel Works, Indicative Culvert and Pipeline Crossing Locations ...	11
Figure 5.9	Phase 5 – Earthworks Profiling.....	15
Figure 5.10	Phase 6 – North Construction Camp and South Construction Facilities Conceptual Layouts .....	16
Figure 5.11	Phase 7 – Enabling Road Closures.....	18

### List of Tables

Table 5.1	Estimated Volumes of Spoil Materials and Intended Reuse.....	12
Table 5.2	STP Design Standards .....	13
Table 5.3	Potentially Hazardous Material Storage Principles.....	19
Table 5.4	Estimated Number of Onsite Construction Plant and Vehicles .....	19
Table 5.5	Estimated Number of Daily Offsite SD2 Infrastructure Vehicle Movements.....	20
Table 5.6	Estimated GHG and Non GHG Emissions Associated with SD2 Infrastructure Activities .....	20
Table 5.7	Estimated Hazardous and Non Hazardous Waste Associated with SD2 Infrastructure Activities.....	21
Table 5.8	Construction Waste Streams .....	22

## 5.1 Introduction

This Chapter of the Environmental and Socio-Economic Impact Assessment (ESIA) describes the activities associated with the SD2 Infrastructure Project. The Project includes the works required prior to the construction, installation, commissioning and operation of the onshore Shah Deniz 2 (SD2) facilities within the SD2 Expansion Area at the Sangachal Terminal.

The main components of the SD2 Infrastructure Project comprise (refer to Figure 5.1):

- Construction of access roads (temporary and permanent) to the SD2 Expansion Area and the associated construction areas;
- Construction of a flood protection berm, drainage channel and improvement works to the existing drainage in the Terminal vicinity;
- Utility works including connections to the mains water supply, sewerage pipework (connecting to a new sewage treatment plant (STP)) and power connections and diversions;
- Preparation of the onshore SD2 Pipeline Landfall Area;
- Profiling of the ground levels across the SD2 Expansion Area; and
- Construction and fit out of the north construction camp and south construction facilities.

In addition, a new road junction will be constructed between the new permanent access road and the Baku-Salyan Highway. BP will be responsible for appointing contractors for all elements of the project scope with the exception of the Baku-Salyan Highway Junction, which will be the responsibility of the Azerbaijan Highways Authority.

It is intended that temporary fencing is erected around all construction works prior to commencement to demarcate the works area and prevent unauthorised access.

This Chapter describes the Base Case Design which has been developed using a masterplan approach. The project has now entered the detailed design phase. It may be necessary as the design progresses to change an element(s) of the project. The Management of Change process that will be followed should this be necessary is presented in Section 5.11 of this Chapter.

Estimated emissions, discharges and waste from the project are presented within Section 5.8 below; emissions estimate assumptions are provided within Appendix 5A.

Figure 5.1 Overview of SD2 Infrastructure Project

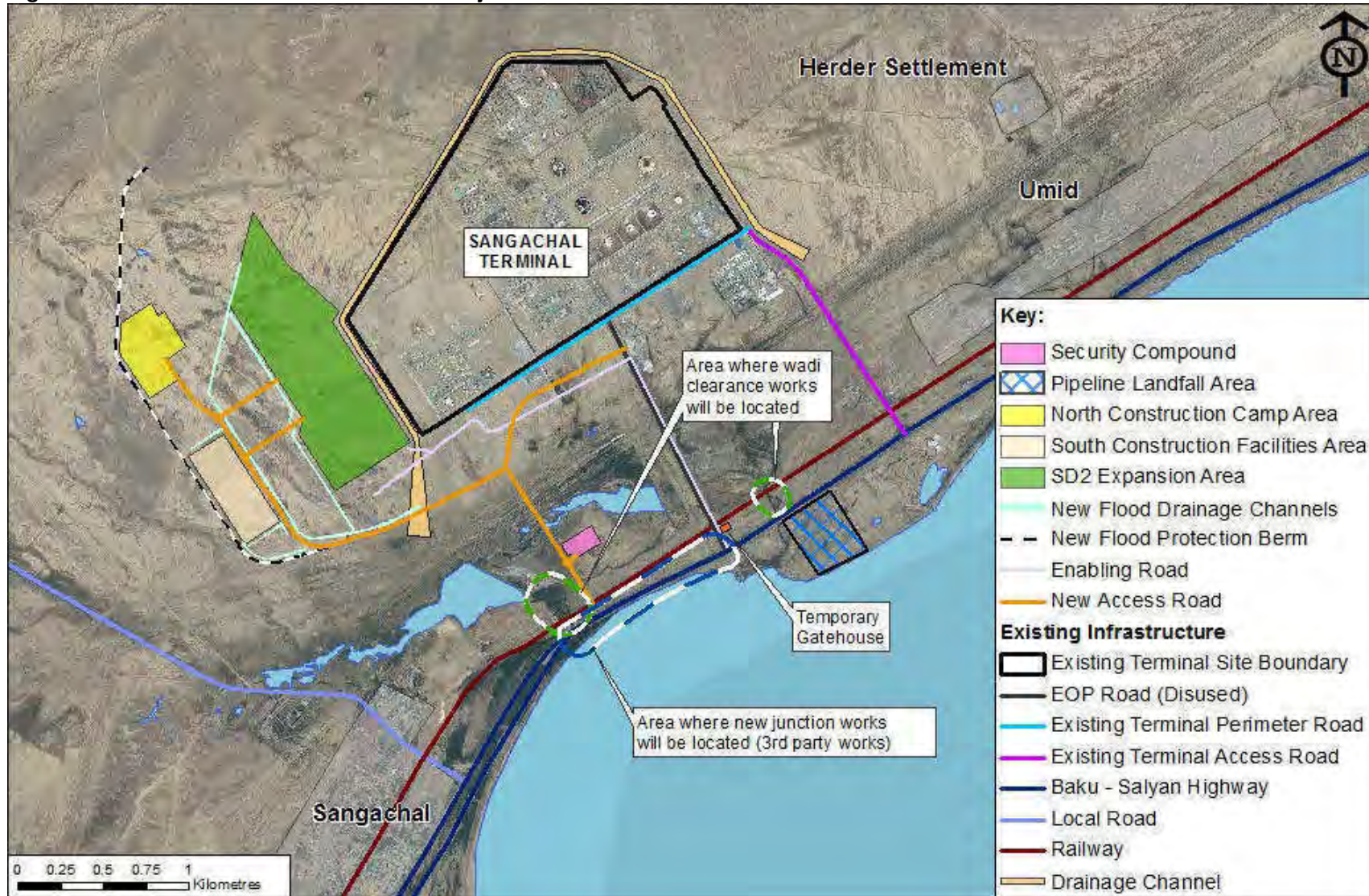



## 5.2 Development Areas and Land Acquisition

A number of the project elements as detailed within Figure 5.1 are planned to be located in areas outside the current Terminal ownership boundary. The maximum extent of land acquisition required is presented within Figure 5.2.

**Figure 5.2 Maximum Extent of Acquisition and Current Terminal Property Boundary**

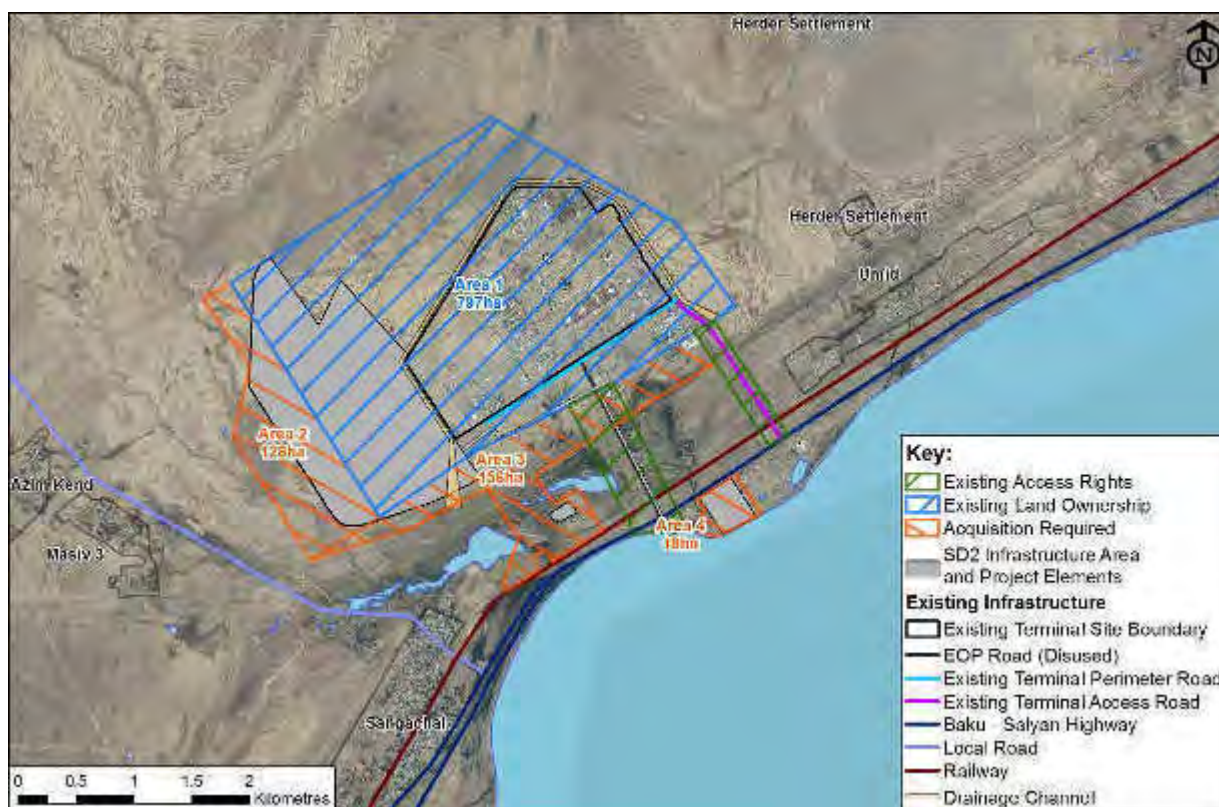

It is planned to acquire up to 302 hectares (ha) to the immediate west and south of the existing Terminal ownership boundary and at the shoreline, where the pipeline landfall is proposed. The area to the west extends beyond the physical boundary of the SD2 Infrastructure facilities to provide space should future development be required.

## 5.3 Logistics and Material Supply

Preference will be given to source equipment (such as plant and construction vehicles) and materials (such as gravel) which meet the required project specifications from within Azerbaijan wherever possible. It is planned to transport this material and equipment to site by road and rail. Where international procurement is required, materials and equipment will arrive by road, rail, sea and air using the transportation routes established for the previous ACG and SD Terminal expansion construction programmes.

Goods arriving via sea can travel by two main routes. From the Mediterranean and Black Sea, vessels must pass through the Don-Volga canal system. Cargoes following the Baltic Sea route, would be transhipped at St. Petersburg and travel along the Baltic-Volga system. These routes are not available during the ice season (November - April).

Rail links are available from Poti in Georgia and Riga in Latvia. Deliveries by road from Europe would be through Turkey and Georgia and via Iran. Figure 5.3 illustrates potential transport routes.

**Figure 5.3 Import Routes to Azerbaijan**



While available transport routes can be identified, the likely use of each and what will be transported cannot be determined with any certainty until the procurement strategy and award of construction contracts has been made. Anticipated construction materials and estimated vehicle movements onsite and offsite are presented in Sections 5.6 and 5.7 below.

### 5.4 Project Schedule

The indicative project schedule is provided within Figure 5.4. Works are expected to last for approximately 18 months, commencing first quarter of 2012.

**Figure 5.4 Indicative SD2 Infrastructure Project Schedule**

Phase	2012				2013	
	Q1	Q2	Q3	Q4	Q1	Q2
Phase 1 Set Up of Initial Site Compound	■					
Phase 2 Establishment of the Enabling Road and Power Diversion Works	■	■				
Phase 3 Site Preparation	■	■	■			
Phase 4 Main Civils Works		■	■	■	■	■
Phase 5 Earthwork Profiling			■	■		
Phase 6 Construction of Camps and Fit Out		■	■	■	■	
Phase 7 Closure of Enabling Road and at Grade Rail Crossings						■

As Figure 5.4 shows the SD2 Infrastructure works comprise a series of phases, each of which include key project activities. These phases will not occur in strict sequential order and there will be overlap between phases, with some activities being undertaken in parallel. The precise sequence of activities will be determined by the contractors appointed to undertake the works. The contractors will be required to sequence activities in accordance with technical and safety requirements and also with reference to principles intended to minimise environmental impacts, e.g. minimise double handling of excavated materials, optimise scheduling of surface soil layer removal to minimise dust impacts etc (refer to Section 5.5.3 below).

The project activities associated with each phase are described below.

## 5.5 Project Phases

### 5.5.1 Phase 1 – Set Up of Initial Site Compound

Phase 1 will involve establishing an initial site compound (of approximately 2 ha) to comprise:

- Temporary site offices;
- Fitters' workshops;
- Welfare facilities of portable, modular construction (to include changing, toilet and catering facilities and first aid station);
- Space for the storage of construction materials and construction equipment/plant/vehicles; and
- Designated areas for fuel, oil and chemicals storage/handling.

Prior to establishing the compound, it is planned to use existing temporary site offices. The compound (approximate area of 7,500m<sup>2</sup>) is planned to be located within the SD2 Infrastructure area (refer to Figure 5.1). It is anticipated that some ground works and levelling will be necessary to prepare the compound area. It is intended that construction traffic will first use the current Terminal site access road and the perimeter road, which will be extended to reach the compound. Minor modifications to the existing Terminal road network, such as the provision of vehicle waiting/passing areas and traffic management measures (refer to Chapter 12) may be necessary to avoid construction traffic causing congestion to existing vehicle movements into and out of the Terminal site.

#### Compound Utilities

Utilities will include:

- **Power** - diesel generators will be used to supply power to the compound offices, workshops and welfare facilities;
- **Water** – water for general use e.g. cleaning, wheel washing will be supplied by tankers and stored in a day tank. Bottled drinking water will be provided;
- **Sewage** – a septic tank will be located at the compound. The contents will be tankered off site for appropriate treatment either to the existing Terminal sewage treatment plant or to a municipal sewage treatment plant; and
- **Drainage** – the compound will be designed to:
  - Route rainwater run-off to the wadi system via the existing Terminal drainage system.
  - Route drainage from parking areas and bunding around hazardous areas (e.g. areas for chemical/fuel storage) to dedicated oil water separator systems, designed such that discharges meet applicable oil in water standards<sup>1</sup>.
  - Route initial site compound canteen waste to a dedicated separation system to remove fats, oil and grease, prior to collection of effluent and solid waste which will be transported offsite for disposal.

<sup>1</sup> Less than 10 mg/l as a monthly average and less than 19 mg/l on a daily basis

## **Waste**

It is planned to appropriately store all wastes at the initial site compound prior to transfer to appropriate disposal facilities offsite. Section 5.8.3 below details the types of waste expected and how waste will be managed across all project phases.

## **Fuel/Chemical Storage and Refuelling**

It is anticipated that above ground fuel diesel tanks will be required to supply equipment in the compound. The tanks will be located in a designated refuelling area, will have secondary containment capable of holding 110% capacity and will be locked when not in use. All refuelling using tanks and bowsers will be supervised and refuelling will be conducted in designated areas. Other fuels, oils and chemicals will be securely stored in clearly marked containers in a contained area to prevent pollution.

### **5.5.2 Phase 2 – Establishment of the Enabling Road and Power Diversion Works**

Phase 2 will involve:

- Establishing the SD2 enabling road to provide initial access to the SD2 Infrastructure area for heavy construction vehicles;
- Establishing of routes across the SD2 Infrastructure area for spoil movement; and
- Diversion of overhead power cables.

#### **Enabling Road**

As Figure 5.5 shows the enabling road will comprise:

- The former EOP road; and
- A new gravel based haul road joining the former EOP road after it crosses the existing pipeline corridor to the SD2 Infrastructure area.

The enabling road works will commence with the closing of the existing access from the former EOP road to the Terminal. Works will then commence to repair the former EOP road and construct the haul road. Activities will also include:

- Reinstatement and upgrade of the road crossing across the Baku–Tbilisi railway;
- Establishing a junction from the enabling road onto the westbound carriageway of the Baku–Salyan highway;
- Installing a temporary rail crossing gatehouse; and
- Construction of temporary at-grade pipeline crossings.

Should it not be possible for any reason not to re-establish the EOP road as an initial access route, an alternative access track may be used to provide access to the SD2 Infrastructure area prior to completion of the new access road (refer to Sections 5.5.3 and 5.5.4 below). There is currently an access track being built to support non BP pipeline replacement work in the 3<sup>rd</sup> party pipeline corridor (to the south west of the Terminal, just north of Sangachal Town). This track may be used as an alternative access route in the event of the EOP road is not re-established.



**Figure 5.5 Phase 2 - Enabling Road**



### Overhead Power Cables

Once the enabling road is established, overhead power line works will commence. It is expected that it will be necessary to raise a number of power lines which cross:

- The former EOP road; and
- The new access road route.

It is also planned to divert a number of power lines which currently cross the south west of the SD2 Infrastructure area either around the SD2 Infrastructure area or to:

- Provide connections to supply the SD2 Infrastructure facilities including the north construction camp and south construction facilities;
- Provide for future connection for the SD2 facilities; and
- Enable reconnection to the existing Terminal.

It is intended that the works will be designed and completed by the power line owner, who will be responsible for managing the works including possible interruptions to power supply.

### 5.5.3 Phase 3 – Site Preparation

Phase 3 comprises:

- Clearance works including:
  - Surface soil layer and vegetation removal; and
  - Removal and redistribution of two existing stockpiles of spoil.
- Construction of the new access road embankments; and
- Construction of the flood protection berm, drainage channel works (including wadi clearance works) and pipeline corridor crossing.

In addition, concrete breaking works may be required within the SD2 Expansion Area to remove existing areas of concrete from previous activities in the area. Figure 5.6 shows the project areas associated with the Phase 3 activities.



**Figure 5.6 Phase 3 – Site Preparation**

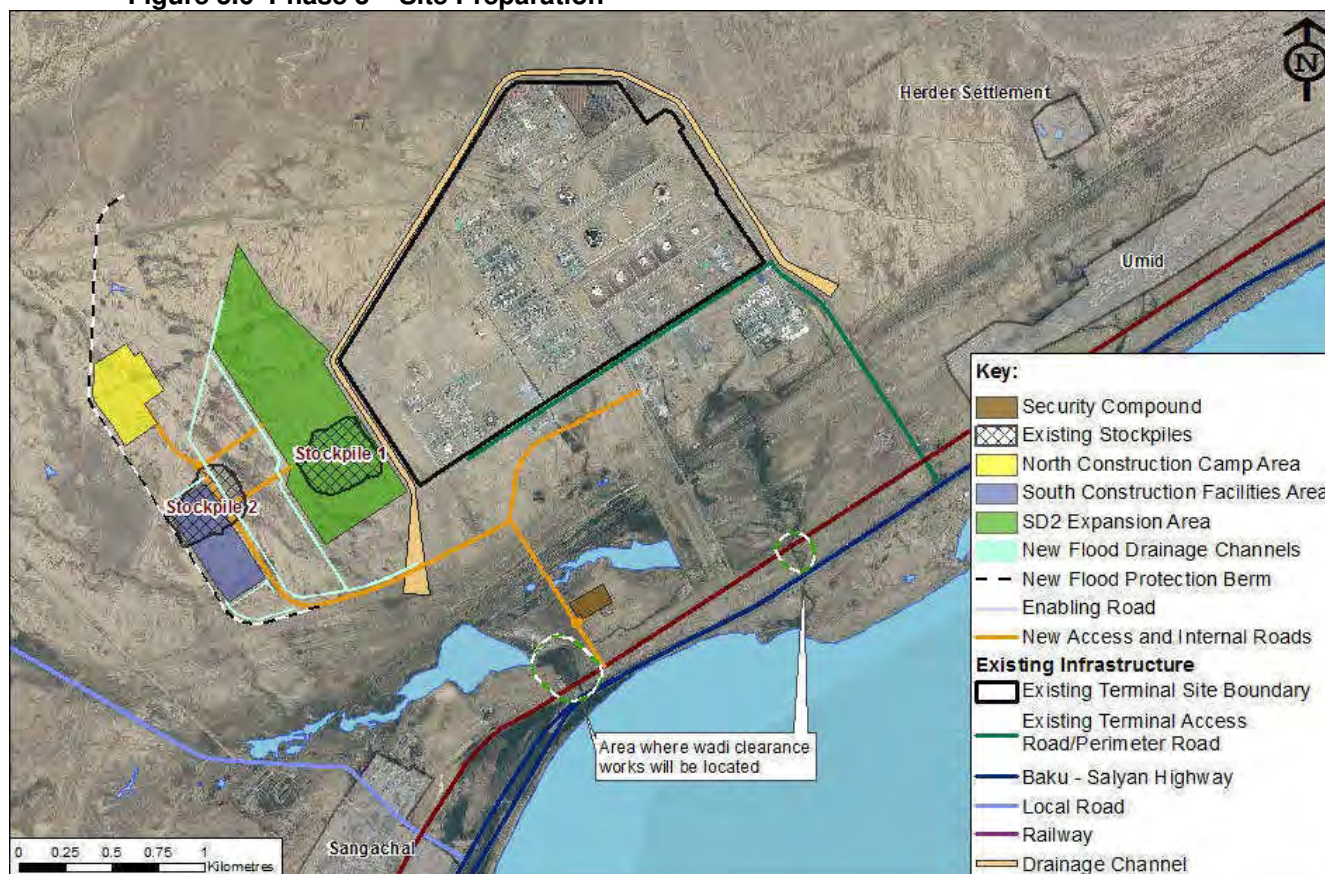

### Clearance Works

Clearance works will include:

- **Surface soil layer and vegetation removal** – clearance works will include the removal of vegetation and a planned strip of surface soil to a depth of approximately 0.15m. Stripped vegetation (including the surface layer of earth held together by its roots) will either be reused or mulched and disposed of in a suitable manner. No burning of stripped vegetation onsite will be undertaken. Surface soil will be used onsite, primarily with the flood protection berm (see Figure 5.7); and
- **Spoil stockpile removal** – the main clearance works comprise the redistribution of two existing stockpiles of spoil as shown within Figure 5.6 to provide structural fill.

Environmental survey work in the third-party pipeline area and in the vicinity of the Shachkaiya Wadi has identified areas with oily contaminated soil and surface water (refer to Chapter 6 Section 6.4.4), which may be encountered during the construction work. These areas are outside the existing Sangachal Terminal property boundary. In the event that oily contaminated soil, ground water, surface water or other materials outside of the existing Sangachal Terminal property boundary are encountered and require handling, then the following procedure will be used:

- Soil, surface water, groundwater or other materials will be relocated to an area that is of comparable environmental quality and function;
- Relocation activities will be undertaken in a manner that will not degrade the environment further and will promote the natural degradation of contaminants; and
- The following information will be recorded; contaminants detected, handling methods adopted to prevent further environmental degradation, location and quantity of contaminated material detected.

Oily contaminated soil, ground water, surface water or other materials are not anticipated within the existing Sangachal Terminal property boundary however, if contaminated materials within the existing Sangachal Terminal property boundary are encountered, then they will be classified and managed as waste in accordance with existing BP waste management procedures.

It is intended that all non-contaminated clearance materials including stripped surface soil and the spoil stockpiles will be reused. The majority of the materials will be used to construct a flood protection berm to the west of the SD2 Infrastructure area, undertake drainage channel works, construct road embankments and provide base fill materials for project areas e.g. north construction camp and south construction facilities. It is not intended to use stripped surface soil for structural fill (e.g. road embankments).

### Flood Protection Berm

A new flood protection berm (refer to Figure 5.6) will be constructed to a height of between 1 to 3m (higher in the section between the construction facilities and construction camp where hydrological modelling has demonstrated flood risk is greatest). A typical cross section is presented in Figure 5.7.

**Figure 5.7 Typical Flood Protection Berm Cross Section**

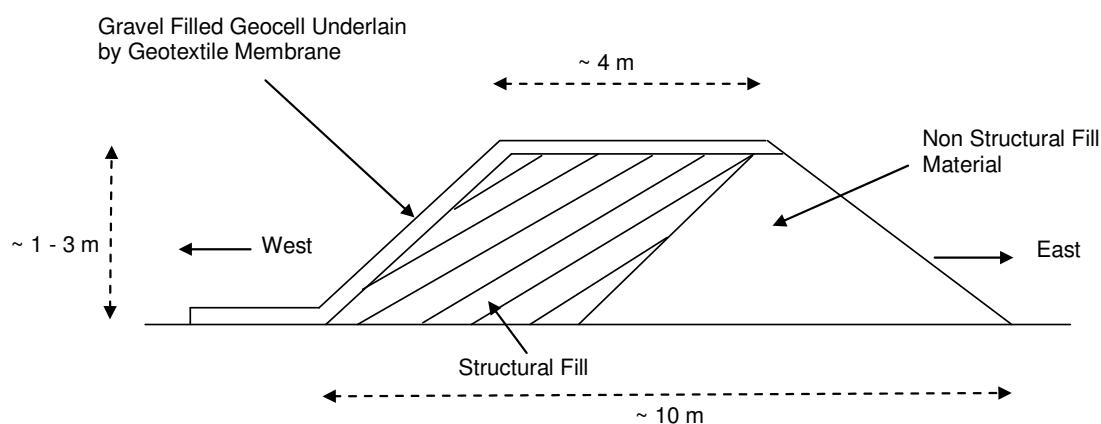

As Figure 5.7 shows surface protection measures, in the form of gravel filled geocells and geotextile membranes, will be taken to protect the exposed structural earthworks of the berm. An emergency access route (minimum 3m in width) will be provided along the top of the berm.

### Drainage Channel and Wadi Clearance Works

These will comprise the following:

- **Wadi clearance works** – Obstructions including rock, vegetation and silt in the existing Western and Central wadi sea outfalls, which have been partially blocked, will be removed;
- **Drainage management** – A low level flood levee will be constructed to the west side of the EOP road, adjacent to the culverts shown in plan 1 of Figure 5.8. This levee is designed to regulate low water flow to the western drainage outfall and prevent regular flooding of the land to the east; and
- **New drainage channel works** - New drainage channels as shown within Figure 5.8 will be constructed. These will incorporate ditches and bunds, lined (with concrete or geotextile) or profiled depending on their location and soil conditions. Protection measures to prevent scour will be incorporated into the design in the vicinity of pipeline crossings. It is planned that the final design of the drainage system will be informed by detailed hydrological modelling based on a 100 year return period flood flows and the results of ongoing geotechnical survey works. The approximate location of culverts to be constructed under the new access road and internal roads



to accommodate the new drainage channels are shown in Figure 5.8. The culverts will be constructed during Phase 4 (refer to Section 5.5.4 below)

Any contaminated materials or spills encountered during drainage channel and wadi clearance works will be managed in same way as contaminated materials or spills encountered during vegetation, surface soil and spoil stockpile removal as described above.

**Figure 5.8 Drainage Channel Works, Indicative Culvert and Pipeline Crossing Locations**

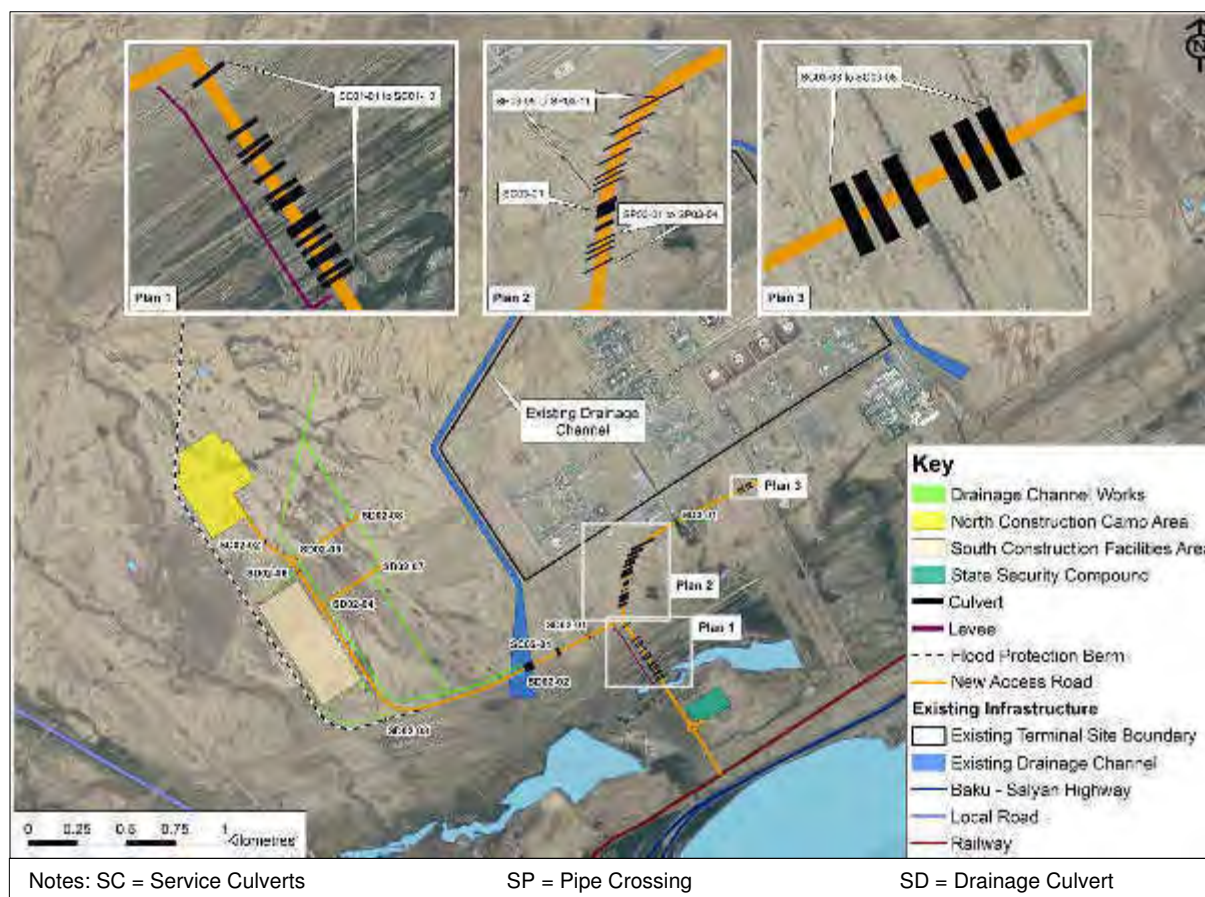

It is intended to use uncontaminated excavated materials from wadi clearance works and the new drainage channel works as structural fill material, where possible.

**Road Embankments**

It is planned that the majority of road embankments will be constructed from reused materials. Where additional surface protection of the embankment is required, gravel or geotextile will be used or the area will be vegetated. In areas prone to flooding, imported materials (e.g. crushed rock gravel) may be required as local soils are known to be prone to water softening.

All new permanent roads will be constructed within a minimum embankment height of 0.4m to protect the roads and associated pedestrian walkways from surface runoff.

**Summary of Spoil Reuse**

Table 5.1 summarises the estimated volumes of spoil materials generated during Phase 3 and their intended reuse.

**Table 5.1 Estimated Volumes of Spoil Materials and Intended Reuse**

Material	Estimated Volume of Materials (m <sup>3</sup> )	Intended Reuse
Stripped vegetation	500	Used for re-vegetation (preferred option) or mulched and disposed of offsite
Stripped surface soil	140,000	Within flood protection berm
Existing spoil stockpiles	440,000	Structural fill material for <ul style="list-style-type: none"> <li>• Access road and internal road embankments</li> <li>• Flood protection berm</li> <li>• Construction camp and construction areas</li> </ul>
Materials arising from wadi clearance works	1,000	
Excavated materials during drainage channel realignment and new drainage channel works	18,000	
TOTAL:	599,500	

Mobile water bowsers will be available throughout the site preparation works to control dust generation. It is assumed the Terminal water supply or treated sewage will be used to replenish these bowsers.

A spoil and landscape management plan will be developed by the appointed contractor to address the potential issues associated with surface soil removal/movement of spoil (e.g. dust generation, soil erosion and runoff). Further details are provided within Chapter 12.

#### 5.5.4 Phase 4 – Main Civils Works

Phase 4 includes:

- Installation of culverts and crossings;
- Completion of the new Terminal access road and other permanent internal roads;
- Utility works including water and drainage pipework and power connections;
- Construction of SD2 support facilities including SD2 STP facilities;
- Construction of the temporary security compound and associated buildings; and
- Preparation of the Pipeline Landfall Area.

During this phase it is intended that the highway junction works will also take place. These comprise building of slip roads, a bridge over the highway and a connection to the new Terminal access road, passing over the railway line.

As stated within Section 5.1, detailed design and construction of the Baku-Salyan Highway Junction will be the responsibility of the Azerbaijan Highways Authority.

#### Installation of Crossings

Works will include the installation of the culverts and crossings under the access road and internal roads as shown within Figure 5.8. The crossings, constructed from concrete, will include sufficient headroom to allow for future maintenance inspection of the utilities, which include gas, oil and water pipelines associated with the existing Terminal and 3<sup>rd</sup> parties. Crossings will also be installed along the proposed route of the future SD2 pipelines including the proposed routing for the future connection from the existing Terminal to the SD2 STP. Crossings located within the state pipeline corridor immediately to the south of the Terminal are expected to require the use of a mini piling system<sup>2</sup>.

It is intended to incorporate sufficient headroom and width in the design of one of the pipeline crossings to allow local herders to cross under the new access road.

<sup>2</sup> A type of piling used in locations where there is restricted headroom.

## Completion of Roads

All permanent roads (i.e. the access road and internal roads) will be completed with a layer of imported gravel and finished to a standard appropriate for construction traffic. It is planned to install permanent lighting along the length of the access road across the state pipeline corridor and adjacent to the construction facilities area.

## Utility Works

Utilities works will be undertaken to connect the construction camp and construction facilities. It is planned to install water supply and drainage pipework and cabling (power supply and telecommunications) adjacent to the access road and internal roads where possible. There are no planned connections to the municipal sewage network or public telecommunication systems. Offsite power connections are discussed in Section 5.5.2 above. Connections with the mains water supply will be managed in liaison with the utility owner.

## SD2 Support Facilities

Works are planned to include:

- **Sewage Treatment Plant** – it is planned to construct and commission a modular type STP, sized to accommodate sewage generated from:
  - North construction camp and south construction facilities;
  - SD2 Terminal Expansion Area; and
  - Existing Terminal areas (note that connection between existing facilities and the new STP is not within scope of the SD2 Infrastructure Project).

The STP will be designed to treat up to approximately 900m<sup>3</sup>/day of domestic water (including grey and black water) to applicable standards (See Table 5.2).

**Table 5.2 STP Design Standards**

Parameter	Units	Limit Value <sup>1, 2</sup>
pH	-	6-9
Residual Chlorine	mg/l	<1 <sup>3</sup>
		<0.2 <sup>4</sup>
BOD	mg/l	20
COD	mg/l	100
Total Suspended Solids (TSS)	mg/l	30
Total Coliforms	MPN/100ml	<400
<b>Notes:</b> 1. All limit values are maximums i.e. not to be exceeded. 2. Unless otherwise stated, limit values are consistent with those agreed for current ACG and SD projects. 3 Applicable to treated sewage used for irrigation or dust control. 4. Applicable to treated sewage discharged to the environment.		

Under routine conditions it is planned that treated sewage will be either:

- Discharged to the Shachkaiya Wadi; or
- Used for irrigation purposes or for dust control where practicable and required.

The STP design does not include sludge treatment and it is planned that, once operational, sludge will be collected. Sewage sludge will be stored in designated containers for collection and disposal to an appropriately licensed facility. No sewage sludge shall be discharged.

- **Waste transfer facility** – an area of approximately 3,000m<sup>2</sup> is allocated within the south construction facilities area for a new waste transfer facility where waste will be segregated and stored prior to transport offsite. It is anticipated that the facility design will be similar to the existing facility at the Terminal.

- **Vehicle refuelling facility** – a dedicated facility will be constructed (approximately 300m<sup>2</sup>) for vehicle refuelling. The area will include lined bunds, sized to contain 110% of the stored fuel capacity. Drainage in the area will be routed to a dedicated oil water separator system, designed to treat water to applicable oil water standards<sup>3</sup>. Once the refuelling facility is operational it is intended that plant and vehicles associated with the SD2 Infrastructure Project will either be refuelled at the facility or in the location they are operating via mobile fuel bowsers. Strict procedures will be followed when refuelling to minimise the risk of spills to the environment.
- **Vehicle wash facility** - a fixed vehicle wash facility will be constructed and bunded with drainage routed to dedicated holding tanks. It is expected the majority of wastewater from the vehicle wash facility will be recycled with the remainder including silt, oil and detergent residue collected into a tank and removed using road tankers.
- **Potable water plant** - designed to treat mains water to potable water standards.

While not included within the Base Case Design, space has been allocated for a concrete batching plant, designed to provide up to 100m<sup>3</sup>/hour of concrete when operational, and an associated area for materials and precast storage.

### Security

Temporary construction security facilities and associated temporary buildings will be installed. Construction areas will be temporarily fenced to segregate construction activities from external publically accessible areas.

### Pipeline Landfall Area

Preparation works for the Pipeline Landfall Area during this phase will include access road preparation, surface soil removal and ground stabilisation. Facilities sized for up to 80 people (to include a water day tank, diesel generators for power supply, a septic tank for sewage, office and welfare facilities) will be sited in an area of hardstanding within the Pipeline Landfall Area.

### 5.5.5 Phase 5 – Earthworks Profiling

Phase 5 includes the main profiling of earthworks for the SD2 Expansion Area (Figure 5.9).

The works involve the preparation by cut, fill and compaction of existing ground within the SD2 Expansion Area into three terrace levels for the future SD2 onshore facilities. A fourth terrace level will be formed but left unprepared. From preliminary calculations it is estimated the cut and fill works will involve approximately 350,000m<sup>3</sup> of material. No import of material is anticipated.

At outline design these terraces cover the following estimated areas:

- Upper terrace (unprepared) 13.85ha;
- Upper terrace (prepared) 10.93ha;
- Middle terrace 18.00ha; and
- Lower terrace 25.63ha.

During the earthworks, it is planned to complete a number of piling trials to investigate the suitability and preliminary pile design for the main SD2 Terminal construction. It is anticipated that piles will be either precast driven or bored cast in-situ concrete. Piling locations will be either within the SD2 Expansion Area or within 100m of the SD2 Expansion Area boundary.

---

<sup>3</sup> Less than 10 mg/l as a monthly average and less than 19 mg/l on a daily basis.



**Figure 5.9 Phase 5 – Earthworks Profiling**

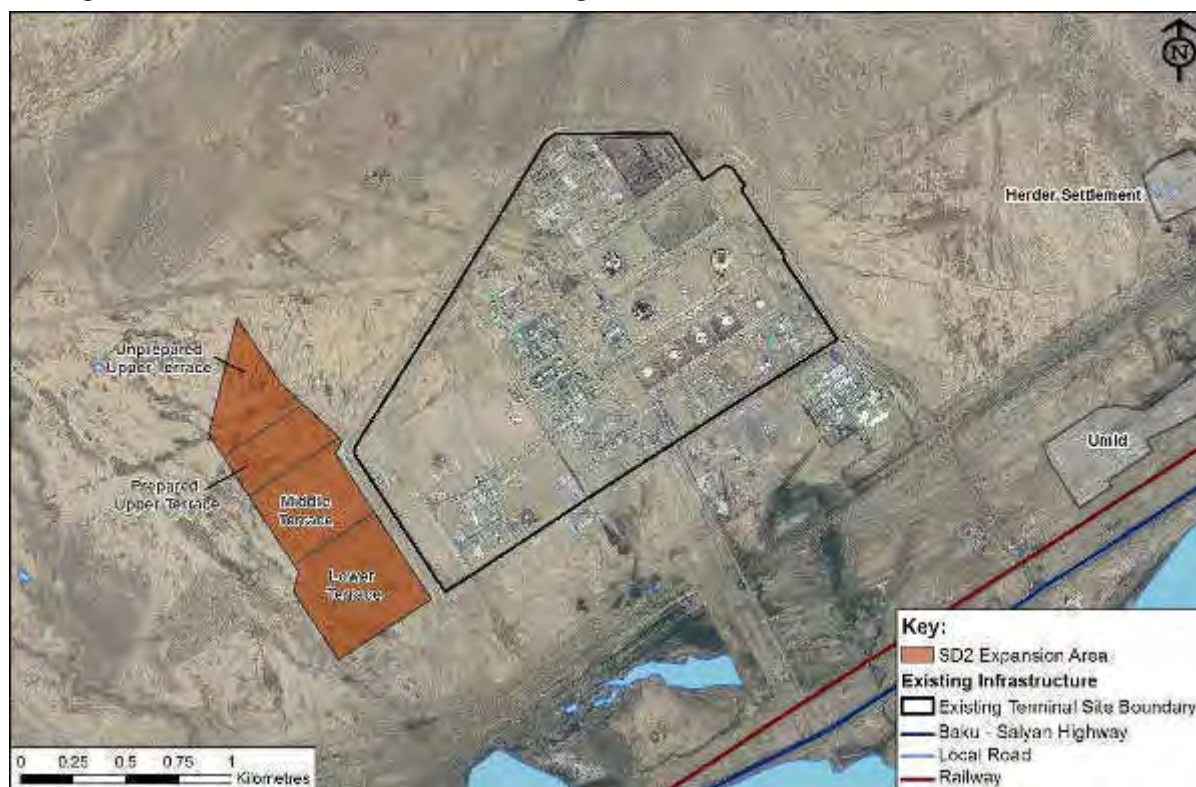

### 5.5.6 Phase 6 – Completion and Fit Out of Construction Camp and Construction Facilities

Phase 6 comprises the completion and fit out of the north construction camp and south construction facilities, which involves:

- The north construction camp - located to the north west of the SD2 Expansion Area. The camp will comprise:
  - Accommodation (for 600 persons);
  - Laundry;
  - Communications and information technology facilities;
  - Washrooms;
  - Security facilities;
  - Lockers; and
  - Welfare and dining facilities.
- The south construction facilities - located to the south west of SD2 Expansion Area. The area will comprise:
  - Offices (for 500 persons);
  - Warehouses;
  - Workshops;
  - Laydown areas;
  - Fabrication areas;
  - Laboratory;
  - Cylinder and fuel store;
  - Vehicle maintenance;
  - Dining facilities (sized to cater for 5,000 persons over staggered sittings);
  - Maintenance and radiographics facilities; and
  - Medical, welfare and changing facilities.

The new STP, refuelling facility, electrical substation, waste transfer facility, vehicle wash facility and potable water plant will be located to the south of the main construction facilities.

Figure 5.10 shows the location of the construction camps and the conceptual layout of both camps. It is planned to construct the construction camp and construction facilities as part of the SD2 Infrastructure works. However, if any residual elements of the construction camp or construction facilities are still to be built at the end of the Infrastructure works, the works will be passed to and become the responsibility of the Main SD2 Construction Works contractor.

**Figure 5.10 Phase 6 – North Construction Camp and South Construction Facilities Conceptual Layouts**

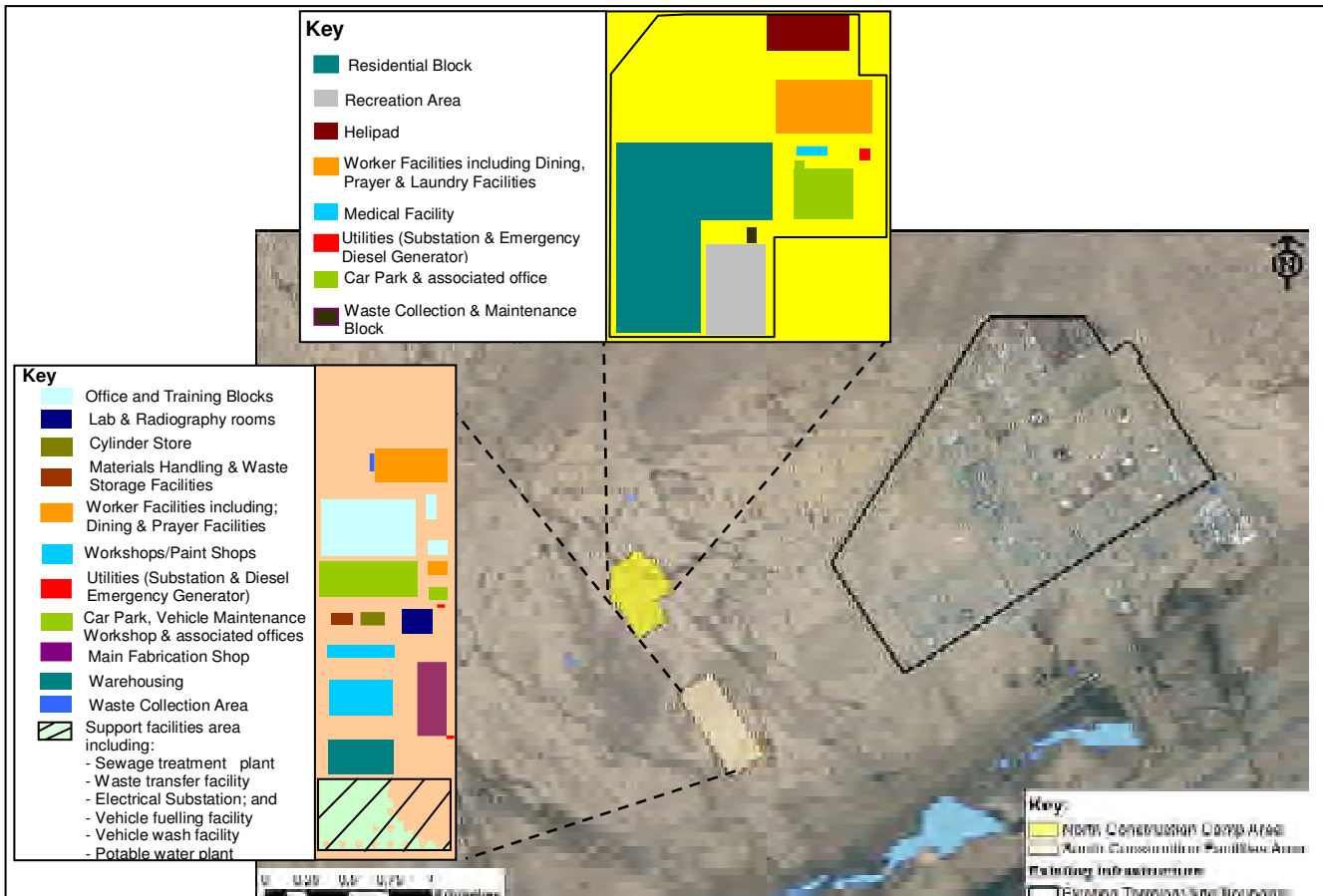

It is expected that the construction camp and construction facilities buildings will be either of a flat pack design (to be assembled on site) or pre-engineered metal buildings. All structures are expected to be no more 10m high once assembled. Typical equipment used in the construction process will be tracked cranes, mechanical diggers, concrete mixers, various power tools and heavy goods vehicles for deliveries (refer to Section 5.7).

When operational all vehicular access into the construction camp and construction facilities will be from the new access road. The road will extend into the camps running south to north, and terminate at the shuttle bus pick-up and drop-off point. The road will also provide access for the staff car parking area.



## Construction Camp and Construction Facility Utilities

The construction camp and construction facilities include provision of connections for utilities such as water supply, sewage treatment, power supply and telecommunications. Works undertaken to establish these connections are provided in Section 5.5.4.

Utilities associated with the camp and facilities areas include:

- **Power** – once operational, supplied from the mains supply or the existing Terminal. Emergency back-up by diesel generators will be provided to the construction camp and the construction camp facilities. When required, the generators will be refuelled from the dedicated refuelling facility by mobile bowsers. Prior to electrical tie-in works, power will be provided from portable diesel powered generator equipment;
- **Water** – non-potable water supplied from the mains water supply. Potable water provided from the potable water plant (see Section 5.5.4). It is expected that the total demand for water (potable and non potable) will be approximately 1,600m<sup>3</sup> water/day during the main SD2 construction works;
- **Sewage** – sent to the new STP (refer to Section 5.5.4 above). Septic tanks will be also located in the construction camp and construction facilities to provide contingency when the STP requires maintenance<sup>4</sup>; and
- **Drainage** – the drainage system within the construction camp and construction facilities area will be designed to:
  - Route rainwater run off to the wadi system via the new drainage channels;
  - Route drainage from parking areas and bunding around hazardous areas (e.g. areas for chemical/fuel storage) to dedicated oil water separator systems, designed such that discharges meet applicable oil in water standards<sup>5</sup>; and
  - Route canteen waste water to the STP via a dedicated system to separate fats, oil and grease to the standard required to minimise potential fouling of the STP.

It is anticipated that pipework associated with the construction camp drainage system will be leak tested and may be superchlorinated. Discharge from the pipework testing and chlorination will meet the applicable sewage<sup>6</sup> and oil water standards<sup>6</sup>.

It is expected that high level lighting, designed in accordance with international standards e.g. ILE requirements, will be erected at the construction camp and construction facilities areas.

### 5.5.7 Phase 7 – Closure of Enabling Road and at-Grade Rail Crossings

Phase 7 of the works will comprise (refer to Figure 5.11):

- Closure of the enabling road (following completion of the Baku-Salyan Highway Junction);
- Decommissioning of the enabling road at-grade railway crossing; and
- Decommissioning of the connection between the enabling road and the Terminal perimeter road.

<sup>4</sup> It is anticipated that the contents of the septic tanks will be tankered off site during maintenance

<sup>5</sup> Less than 10 mg/l as a monthly average and less than 19 mg/l on a daily basis

<sup>6</sup> pH (6-9), 5 day BOD of less than 20mg/l, total coliforms <400MPN (Most Probable Number) per 100ml, COD of less than 100mg/l, suspended solids of less than 30mg/l and residual chlorine less than 1mg/l.(used for irrigation) or less than 0.2mg/l.(discharge to the environment)

**Figure 5.11 Phase 7 - Enabling Road Closures**

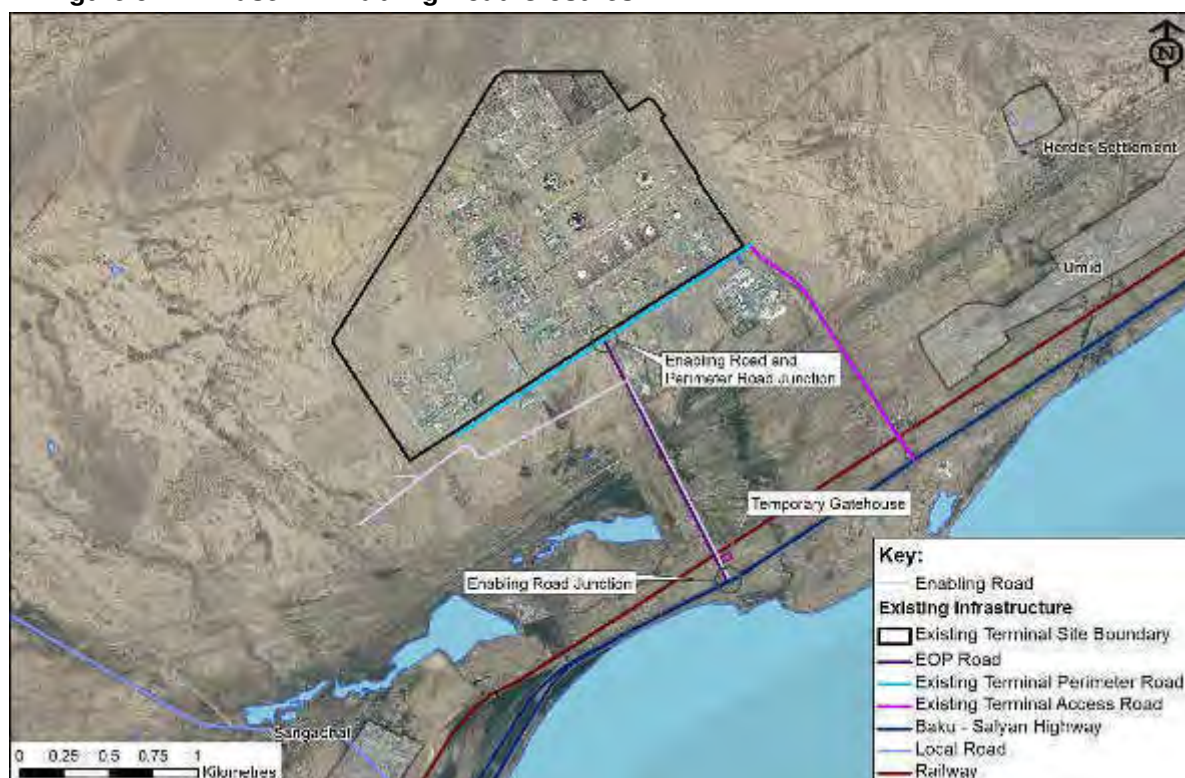

Barriers, which are likely to include earth mounds, will be established at the junction of the enabling road with the Baku-Salyan Highway to prevent access. The at-grade rail crossing will be decommissioned and the connection point for the enabling road with the Terminal perimeter road will also be blocked to prevent vehicles on the perimeter road turning into it.

## 5.6 Construction Materials

SD2 Infrastructure Project construction materials are expected to comprise:

- Stripped vegetation and surface soil;
- Excavated materials and existing stockpile spoil;
- Hazardous liquids including fuels, oils, paints, solvents and bitumen;
- Precast concrete structures;
- Cabling;
- Geocell structures e.g. for the flood protection berm;
- Gravel (for permanent road and construction area surfacing);
- Cement;
- Plastic and stainless steel piping (for water and sewage);
- Modular structures e.g. the security compound building;
- Pre-cast steel buildings and structures e.g. workshops within the construction facilities area and safety barriers along road embankments;
- Chain link fencing; and
- Other prefabricated elements such as the STP.

Table 5.3 summarises the principles that will be adopted with regard to storage of potentially hazardous materials.

**Table 5.3 Potentially Hazardous Material Storage Principles**

Potential Hazardous Material	How and where it will be stored
Stripped surface soil	No storage anticipated. Uncontaminated surface soil to be used directly within flood protection berm.
Stripped vegetation	Either separated from surface soil and subsoil stored until re-vegetation activities commence or mulched and handled as waste (refer to Section 5.8.3 below).
Excavated materials and existing stockpile spoil	Separated from surface soil and stockpiled on site until required in accordance with spoil and landscape management plan (refer to Chapter 12).
Fuels and Oils in containers	Within secondary containment capable of holding 110% of the stored volume.
Bitumen, paint, solvents, grease	Within a site storage container or on hardstanding away from sensitive areas (e.g. watercourses).
Bags and sacks of materials (e.g. cement)	Off the ground on pallets and protected from the weather.

Any oily contaminated soil, ground water, surface water or other materials encountered inside or outside of the existing Sangachal Terminal property boundary during the works that requires handling will be managed in accordance with the principles described in Section 5.5.3. All other materials will be secured and appropriately stored until required for the construction works.

## 5.7 Construction Plant/Vehicles/Equipment

### 5.7.1 Numbers of Onsite Plant/Equipment/Vehicles

The estimated number of construction plant and vehicles expected to be used onsite during each phase of the SD2 Infrastructure works is presented in Table 5.4.

**Table 5.4 Estimated Number of Onsite Construction Plant and Vehicles**

Construction Equipment	Capacity/ Specification	Estimated Number of Plant/Equipment per Phase						
		Phase 1	Phase 2	Phase 3	Phase 4	Phase 5	Phase 6	Phase 7
Bulldozer	D6/D8/D9/D10	1	1	6	6	6		
Wheeled loader	25 tonnes	2	2	5	5	5		
Tracked excavator	27 tonnes	1	1	5	5	5		
Dump truck	25 tonnes	2	2	38	38	38		1
Motor grader	25 tonnes	1	1	2	3	5		
Road roller	10 tonnes				2	1		
Sheep footed roller/vibro roller	13 tonnes	1	1	2	1	3	3	
Asphalt paver					3			
Road lorry	25 tonnes	8	4	28	28	28	11	
Diesel generator	50/100 kVA	1	2	7	7	7	9	1
Mechanical water bowser	20,000 litres	1	7	7	7	8	8	
Tracked mobile crane	115 tonnes		2	2	2	1	4	
Mobile telescopic crane	25 tonnes		1	2	3	1	1	
Earthworks compactor / roller	10 tonnes			7	7	7		
Large lorry concrete mixer	200 litres		1	2	3	2	1	
Fork lift truck	5 tonnes	1	3	3	3	3	1	
Water pump	20 kW	1	2	6	6	2	1	
Concrete pump	110 m <sup>3</sup>			2	3	1	2	
Air Compressor	8/20 m <sup>3</sup> /min	1	2	2	2	2	1	1
Backhoe loader	10 tonnes		4	3		2	2	
Welding set		1	1	2	2	2	2	1
Compactor plate			1	2	2	2	6	
JCB tractor		1	1	2	2	2	4	1
Tilting drum mixer	80 litres		1	1	1	1	4	1
Fuel bowser	10,000 litres	1	1	1	1	1	1	1
Basis of estimate: Typical equipment expected per phase based on expected activities Number of plant/equipment based on expected duration of works.								

## 5.7.2 Numbers of Offsite Vehicles and Routing

The estimated number of daily vehicle movements associated with the SD2 Infrastructure Project on the public road network are presented in Table 5.5.

**Table 5.5 Estimated Number of Daily Offsite SD2 Infrastructure Vehicle Movements**

Vehicle		Estimated Number of Daily Movements				
		Months 1 –2	Months 3 –4	Months 4 –10	Months 11 –17	Month 18
Low loader	In	1	3	1	1	
	Out	1	3	1	1	
Road lorry 25 T	In	1	2	20	2	
	Out	1	2	20	2	
Minibus (18-20 Seater)	In	3	15	30	30	3
	Out	3	15	30	30	3
7.5 Tonne Flat Bed	In	1	2	2	2	
	Out	1	2	2	2	
4x4 Pickup Truck	In	4	8	8	8	4
	Out	4	8	8	8	4
Private Car	In	5	20	20	20	10
	Out	5	20	20	20	10

All the vehicles detailed within Table 5.5 will travel along the Baku-Salyan Highway. Until the procurement strategy has been determined it is not possible to confirm likely vehicle routing. Current traffic flows on the highway area are discussed within Chapter 7.

## 5.8 Emissions, Discharges and Waste

### 5.8.1 SD2 Infrastructure Project Emissions

Table 5.6 summarises the GHG (i.e. CO<sub>2</sub> and CH<sub>4</sub>) and non GHG emissions predicted to be generated during the SD2 Infrastructure Project from key sources which include:

- Onsite construction plant, vehicles and generators; and
- Offsite vehicles.

**Table 5.6 Estimated GHG and Non GHG Emissions Associated with SD2 Infrastructure Activities**

	CO <sub>2</sub> (ktonne)	CO (tonne)	NOx (tonne)	CH <sub>4</sub> (tonne)	NM VOC (tonne)	GHG (ktonne)
TOTAL	137	502	2,120	7	220	137

See Appendix 5A for detailed emission estimate assumptions.

### 5.8.2 SD2 Infrastructure Project Discharges

Planned routine discharges during the SD2 Infrastructure Project will comprise:

- **Storm/rain water drainage** – all project areas will be designed such that rainwater is discharged to the wadi system via the new and existing Terminal drainage channels to prevent flooding and ponding of water on site. Material storage locations (e.g. spoil stockpiles, cement) will be selected to minimise the potential for entrainment into the drainage system;
- **Discharge from oil water separator systems** – oil water separator systems (associated with drainage from parking areas, refuelling area and hazardous areas where fuels and chemicals are stored) will be designed such that discharges to the wadi system meet the applicable oil in water standards<sup>7</sup>;

<sup>7</sup> Less than 10 mg/l as a monthly average and less than 19 mg/l on a daily basis.

- **Construction camp drainage pipework testing** – it is planned to leak test the pipework associated with the construction camp drainage system. In addition super chlorination may be undertaken. Discharges from testing and chlorination (which meet the applicable sewage (see Table 5.2) and oil in water<sup>8</sup> standards) will be either:
  - Discharged to the Shachkaiya Wadi; or
  - Used for irrigation purposes or for dust control where practicable and required.
- **Treated effluent (from the new STP)** - The STP is designed to treat approximately 900m<sup>3</sup>/day. Treated sewage (which meets the applicable project standards (refer to Table 5.2) from the new STP (once operational) will be either:
  - Discharged to the Shachkaiya Wadi; or
  - Used for irrigation purposes or for dust control where practicable and required.

### 5.8.3 SD2 Infrastructure Project Hazardous and Non Hazardous Waste

The estimated quantities of non-hazardous and hazardous waste generated during the SD2 Infrastructure Project programme are provided in Table 5.7.

**Table 5.7 Estimated Hazardous and Non-Hazardous Waste Associated with SD2 Infrastructure Activities<sup>1</sup>**

Type	Waste Category	Sub Category	Estimated Volume (tonnes) <sup>2</sup>
Non hazardous waste	Non-hazardous non - recyclable waste	General Waste	2,335
		Canteen waste	
	Recyclable waste	Cooking oil	1,750
		Electrical cable	
		Paper and card	
		Plastics	
		Scrap metal	
		Tyres	
<b>Total (Non-hazardous)</b>		<b>4,085</b>	
Hazardous waste	Solid hazardous waste	Cartridges	80
		Oily soil/sludge	
		Oily rags	
		Paint sludge	
		Other solids requiring pretreatment for landfill	
		Other solids not requiring pretreatment for landfill	
	Hazardous liquid waste	Chemicals	50
		Oily water	
Paint thinners			
Used oil/diesel			
<b>Total (Hazardous)</b>		<b>130</b>	

<sup>1</sup> Treatment and disposal routes are detailed in Table 5.8.

<sup>2</sup> Types and estimated volumes of waste based on actual waste volumes recorded during previous ACG projects and the proposed SD2 Infrastructure Project schedule and activities.

Waste produced during each phase of the SD2 Infrastructure works will be segregated and temporarily stored onsite prior to transportation to the existing Sangachal Terminal Central Waste Accumulation Area (CWAA) or the new SD2 waste transfer facility once complete. Waste management plans and procedures, including requirements and the responsibilities of the construction contractor and BP, are detailed within Chapter 12. The planned destination of each SD2 Infrastructure waste stream is presented in Table 5.8.

<sup>8</sup> Less than 10 mg/l as a monthly average and less than 19 mg/l on a daily basis

**Table 5.8 Construction Waste Streams**

Category	Sub Category	Destination
Non-hazardous non-recyclable waste	General Waste	Non-hazardous landfill – current facility has been designed and constructed to EU standards.
	Canteen waste	
Recyclable waste	Cooking oil	Recycling contractors – SOFAZ to receive revenue from waste with inherent remaining value e.g. steel.
	Electrical cable	
	Paper and card	
	Plastics	
	Scrap metal	
	Tyres	
	Wood	
Solid hazardous waste	Cartridges	Treatment/disposal by MENR licensed, BP approved contractor or storage pending availability of appropriate contractor.
	Oily soil/sludge	
	Oily rags	
	Paint sludge	
	Other solids requiring pre-treatment for landfill	
	Other solids not requiring pre-treatment for landfill	
Hazardous liquid waste	Chemicals	Treatment/disposal by MENR licensed, BP approved contractor or storage pending availability of appropriate contractor.
	Oily water	
	Paint thinners	
	Used oil/diesel	

## 5.9 Training and Employment

It is estimated that the SD2 Infrastructure works are likely to employ between 450 to a peak of 700 people. It is expected that 30% of the workforce will comprise professional staff. A Workforce Welfare and Local Employment Plan will be produced; the key aim of which will be to maximise the employment opportunities for local people (refer to Chapter 12 for details).

## 5.10 Working Hours and Night-time Working

Construction working hours are assumed to be:

- 07:00 to 19:00 Monday to Saturday.

While not planned, night and Sunday working may be required depending on the progress of the works. If working during the hours of darkness, temporary lighting may be required. The contractor will be required to produce a lighting strategy to minimise light spillage and glare to the community, road users and the shoreline while not comprising safety (refer to Chapter 12).

## 5.11 Management of Change Process

During the detailed design and execution stages of the SD2 Infrastructure Project, there may occasionally be a need to change a design element or a process. The project intends to implement a formal process to manage and track any such changes, and to:

- Assess their potential consequences with respect to environmental and socio-economic impact; and
- In cases where a new or significantly increased impact is anticipated, to inform and consult with the MENR to ensure that any essential changes are implemented with the minimum practicable impact.

All proposed changes will be notified to the Project HSE team, who will review the proposals and assess their potential for creating environmental or socio-economic interactions.

Changes which do not alter existing interactions or impacts, or which give rise to no new interactions or impacts, will be summarised and periodically notified to the MENR, but will not be considered to require additional approval.

If internal review and assessment indicates that a new or significantly increased impact may occur, the following process will be applied:

- Categorisation of the impact using ESIA methodology;
- Assessment of the practicable mitigation measures;
- Selection and incorporation of mitigation measures; and
- Re-assessment of the impact with mitigation measures in place.

In practical terms, the changes that will require prior engagement and approval by the MENR are those that:

- Result in a discharge or disturbance to the community that is not described in the SD2 Infrastructure ESIA; and
- Result in the discharge of a chemical not referenced in the ESIA and not currently approved by the MENR for use in the same application by existing AGT operations.

Once the changes (and any appropriate mitigation) have been assessed as described above, a technical note will be submitted to the MENR describing the proposal and reporting the results of the revised impact evaluation. Where appropriate, this may include the results of environmental testing and modelling. Following submission of the technical note, the Project HSE team will engage in meetings and communication with the MENR in order to secure formal approval. Once approved, each item will be added to a register of change. The register will include all changes, including those non-significant changes notified in periodic summaries, and will note any specific commitments or regulatory requirements associated with those changes.





## 6 Environmental Description

### Contents

6.1	Introduction.....	3
6.2	Data Sources.....	3
6.3	Physical Environment.....	6
6.3.1	Seismicity.....	6
6.3.2	Climate.....	6
6.3.3	Temperature.....	6
6.3.4	Precipitation.....	6
6.3.5	Wind.....	7
6.4	Terrestrial Environment.....	7
6.4.1	Setting.....	7
6.4.2	Hydrology.....	8
6.4.3	Geology, Soils and Historical Pollution.....	11
6.4.4	Groundwater and Surface Water.....	12
6.4.5	Air Quality.....	15
6.4.6	Noise.....	19
6.4.7	Terrestrial Ecology.....	22
6.5	Coastal Environment.....	28
6.5.1	Setting.....	28
6.5.2	Coastal Habitat.....	28
6.5.3	Coastal Birds.....	29
6.6	Archaeology and Cultural Heritage.....	31

### List of Figures

Figure 6.1	Terrestrial and Coastal Areas Associated with the SD2 Infrastructure Project.....	5
Figure 6.2	Annual Wind Rose (Sangachal Terminal), 2007.....	7
Figure 6.3	Main Drainage Catchment Areas in the Vicinity of the Terminal.....	9
Figure 6.4	Locations of Abandoned Exploratory Drilling Wells and Soil and Groundwater Monitoring Boreholes.....	11
Figure 6.5	Observed Spills in Wetland Vicinity, June 2011.....	14
Figure 6.6	Ambient Air Quality (2009 & 2010) and Odour Monitoring Locations (2010).....	15
Figure 6.7	Noise Survey Locations, 2010 and 2011.....	20
Figure 6.8	Approximate Distributions of Plant Community Types (Habitats) Around the Terminal.....	23
Figure 6.9	Major Vegetation Types within SD2 Infrastructure Area (as surveyed), 2008.....	23
Figure 6.10	Bird Monitoring Locations Around the Terminal (2008, 2009 and 2010).....	27
Figure 6.11	Important Ornithological Sites Located on the Southwest Caspian Coast.....	30
Figure 6.12	Bird Migration Routes.....	31
Figure 6.13	Archaeological Survey Finds/Cultural Heritage Sites, 2001.....	32
Figure 6.14	The SD2 Pipeline Landfall Area and the Area Undisturbed Through Quarrying.....	33
Figure 6.15	Courtyard Interior of the Caravanserai.....	34

### List of Tables

Table 6.1	Relevant Baseline and Monitoring Surveys Completed to Date.....	4
Table 6.2	Average Monthly Rainfall Data (Baku) 2002 to 2006.....	6
Table 6.3	SD2 Infrastructure Area Soil Sample Results, 2008.....	12
Table 6.4	TPH and Heavy Metal Results of Groundwater Samples, 2008.....	13
Table 6.5	Results of Surface Water Samples, 2006 Survey.....	13
Table 6.6	Average NO <sub>2</sub> Air Quality Concentrations, 2009 and 2010 (µg/m <sup>3</sup> ).....	16
Table 6.7	Average SO <sub>2</sub> Air Quality Concentrations, 2009 and 2010 (µg/m <sup>3</sup> ).....	17
Table 6.8	Average Benzene and VOC Concentrations, 2009 and 2010 (µg/m <sup>3</sup> ).....	17
Table 6.9	PM <sub>10</sub> Concentrations, 2009 and 2010 (µg/m <sup>3</sup> ).....	18

Table 6.10	2010 and 2011 Noise Survey Results at Sensitive Receptors and Roadside Monitoring Locations .....	21
Table 6.11	Breeding and Incubation Periods of the Spur-Thighed Tortoise .....	27
Table 6.12	Summary of 2001 Archaeological Survey Finds/Cultural Heritage Sites .....	31

## 6.1 Introduction

This Chapter describes the terrestrial and coastal environments associated with the SD2 Infrastructure Project. These are defined as (refer to Figure 6.1):

- **Terrestrial:** The areas to the east, west and north of the Sangachal Terminal and the area to the south between the Terminal and the Baku-Salyan Highway, which includes the wetland areas to the south of the Terminal; and
- **Coastal:** The zone between the Baku-Salyan Highway and the Caspian Sea shoreline<sup>1</sup>.

## 6.2 Data Sources

A large number of environmental surveys and investigations have been undertaken in the area surrounding the Terminal and adjacent coastal areas.

Between 1994 and 2004, environmental surveys have focused on investigating baseline conditions for flora and fauna, air quality, noise and contamination. Since 2004, the Integrated Environmental Monitoring Programme (IEMP) has collected data on:

- Ambient air quality at selected receptors in the vicinity of the Terminal;
- Soil, groundwater and surface water conditions from boreholes and surface water sampling points in the vicinity of the Terminal;
- Flora, fauna, vegetation and soil stability within the Terminal surrounds; and
- Ongoing birds survey in and around Sangachal Bay.

The primary aim of the IEMP is to develop reliable and consistent time series data for each location within a clearly defined survey area to enable long-term trends to be identified.

Under the SD Production Sharing Agreement (PSA), responsibility for the preparation and approval of environmental surveys associated with the IEMP rests with the Environmental Sub-Committee (ESC), which carries out an annual review of planned survey activities. The ESC comprises representatives of key stakeholders such as the State Oil Company of Azerbaijan (SOCAR), the Council of Ministers, the Ministry of Ecology and Natural Resources (MENR) and the Azerbaijan National Academy of Sciences (ANAS). Practical supervision and review of ongoing activities is delegated to the ACG & SD Environmental Monitoring Technical Advisory Group (EMTAG), which comprises environmental specialists representing these organisations.

In addition to the ongoing IEMP surveys, a number of specific surveys have been undertaken to gather additional environmental data. These include noise, odour, visual context and light surveys.

A list of all relevant surveys completed since 1992 is provided in Table 6.1.

A geotechnical survey within the areas to the west and south of the existing Terminal (including the SD2 Infrastructure area) is ongoing. The scope of the survey includes the collection of soil and groundwater samples. In addition, an archaeological survey is planned for 2011 covering the SD2 Infrastructure area (refer to Section 6.6). The results of previous surveys completed during preparation of previous ACG Phases 1-3 and SD Environmental and Socio-Economic Impact Assessments (ESIAs) are referenced in sections of this chapter where relevant.

---

<sup>1</sup> The wider Western Caspian coastal region is described with regard to overwintering and migrating bird species

**Table 6.1 Relevant Baseline and Monitoring Surveys Completed to Date**

<b>Date</b>	<b>Title of Survey</b>
<b>Terrestrial Surveys</b>	
1996	EOP Sangachal Terminal Survey
2001	Terrestrial Soil and Groundwater Survey
2001	Breeding Bird Monitoring Survey Sangachal
2001	Phase 1 Terrestrial Survey
2002	Phase 2 Terrestrial Survey
2003	Sangachal Terminal Watershed Analysis
2003	Sangachal Wetlands Survey Summer/Autumn 2002
2004	Breeding Bird Monitoring Survey Sangachal
2004	Integrated Terrestrial Ecosystem Monitoring Survey - Spring
2004	Integrated Terrestrial Ecosystem Monitoring Survey – Autumn
2005	Integrated Terrestrial Ecosystem Monitoring Survey - Spring
2005	Integrated Terrestrial Ecosystem Monitoring Survey – Autumn
2005	Breeding Bird Survey, Sangachal
2006	Sangachal Terminal Ambient Air Quality Monitoring
2006	Sangachal Terminal Terrestrial Monitoring Survey - Spring
2006	Sangachal Terminal Terrestrial Monitoring Survey - Autumn
2006	Ambient Ground and Surface Water Monitoring
2006	Onshore Ambient Monitoring (Sangachal): Hydrology & Hydrogeology – Phase I
2007	Sangachal Terminal Ambient Air Quality Monitoring
2007	Sangachal Terminal Terrestrial Monitoring Survey - Spring
2007	Sangachal Terminal Terrestrial Monitoring Survey - Autumn
2008	Sangachal Terminal Ambient Air Quality Monitoring
2008	Onshore Ambient Monitoring (Sangachal): Hydrology & Hydrogeology – Phase II
2008	Sangachal Terminal SD2 Expansion Area Flora and Fauna Survey
2008	Sangachal Terminal – Surface and Subsurface Water and Landscape Management Study
2008	Hydrological Survey Report
2008	Onshore Ambient Monitoring (Sangachal) Bird Monitoring Survey Report
2009	Sangachal Terminal Ambient Air Quality Monitoring
2009	Onshore Ambient Monitoring (Sangachal) Bird Monitoring Survey Report
2009	Onshore Ambient Monitoring (Sangachal): Terrestrial Monitoring Survey Spring & Autumn 2009
2010	Sangachal Wetland Survey Report*
2010	Onshore Ambient Monitoring (Sangachal) Bird Monitoring Survey Report*
2010	Sangachal Terminal Baseline Noise Survey
2010	Sangachal Terminal Visual Context Baseline Survey Report & Road Route Photographic Survey
2010	Sangachal Terminal Odour Assessment
2010	Sangachal Terminal Light Baseline Survey Report
2010	Sangachal Terminal Ambient Air Quality Monitoring*
2011	Sangachal Terminal Noise Surveys
<b>Coastal Surveys</b>	
1996	Pipeline Landfall Survey: Sediments and Macrobenthos
1996	Sangachal Coastal Environmental Survey, 1996
2000	Sangachal Coastal Environmental Survey, 2000
2002/2003	Overwintering Bird Survey, Absheron to Kura
2004	Overwintering Bird Survey, Absheron to Kura
2004	Winter Waterfowl Monitoring Study. Absheron to Kura
2005	Winter Waterfowl Monitoring Study. Absheron to Kura
2006	Winter Waterfowl Monitoring Study. Absheron to Kura
2010	Sangachal Subsea Pipeline Landfall Area Rehabilitation and Monitoring Survey Report
2010	Sangachal Bay Shoreline Photographic Survey Report
* IEMP survey – report not yet issued	

**Figure 6.1 Terrestrial and Coastal Areas Associated with the SD2 Infrastructure Project**

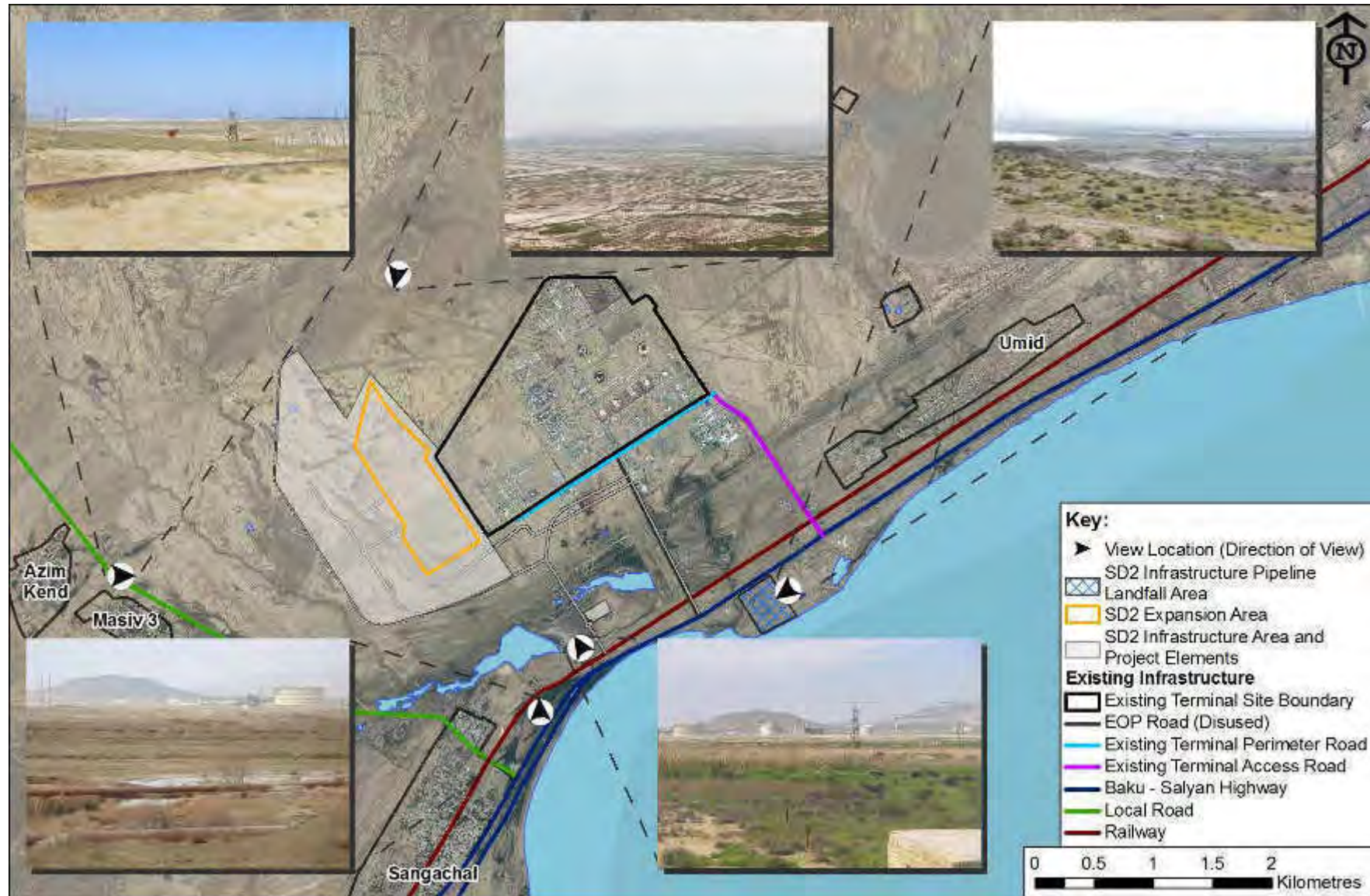

## 6.3 Physical Environment

### 6.3.1 Seismicity

The Caspian region, which is part of the Eurasian continental plate, has a convergent plate boundary with the Arabian and Indian continental plates. This has led to the destruction of an ocean (Tethys), which lay, between Eurasia to the north with Africa and India forming its southern shores. The mountain chains of the Alps, Caucasus and the Karakorum/Himalayas are composed of upthrust rocks formed in, and around, this ancient ocean. Convergent plate movements are associated with relatively high levels of seismic activity and typically accompanied by earthquakes and volcanism.

Azerbaijan is known for its seismic activity, particularly in the Greater and Lesser Caucasus Mountains. Five earthquakes with a magnitude greater than 6.0 on the Richter scale have occurred since 1842; the most recent measured 6.5 on 25 November 2000 with an epicentre 30km east-north east of Baku. More detailed information on the seismicity and tectonics of the area can be found in the ACG Phase 1 ESIA<sup>2</sup>.

### 6.3.2 Climate

Climatic data, with the exception of wind and rainfall data, for the period 1977 to 2000 has been collected from the meteorological station at Alyat which is located approximately 25km south of Sangachal.

### 6.3.3 Temperature

The onshore Sangachal area is classified as being warm, semi-arid desert, with an annual mean air temperature of 14.4 degrees Celsius (°C). July is the warmest month of the year with a 23-year mean average air temperature of 26.4°C between 1977-2000. January is the coldest month with an average of 0°C. Temperature extremes of -16°C and 41°C have been recorded historically in January and July, respectively.

### 6.3.4 Precipitation

The onshore Sangachal area is one of the driest in Azerbaijan. Rainfall data is collected from Alyat, Baku and Mashtaga<sup>3</sup>. Mean annual rainfall in Baku from 1992 to 2006 was 263mm. The highest monthly rainfall from 2002 to 2006 was 184mm in December 2002. October to February are wet months which receive an average of 41 to 79mm/month, with drier months occurring during from July to August which receive an average of 1 to 5mm/month.

Table 6.2 presents average monthly rainfall data from the meteorological station at Baku from 2002 to 2006.

**Table 6.2 Average Monthly Rainfall Data (Baku) 2002 to 2006**

	J	F	M	A	M	J	J	A	S	O	N	D
<b>Average monthly rainfall (mm)</b>	41	43	25	31	20	10	5	1	24	46	46	79

<sup>2</sup> ACG1 ESIA, 2002

<sup>3</sup> Refer to Appendix 9E: Hydrological Modelling of this ESIA



### 6.3.5 Wind

The wind regime in Sangachal Bay is generally consistent with that for the Absheron Peninsula, although it is recognised that there is a local thermally driven wind system. The effects of the local system are most noticeable offshore within the Bay, resulting in a slight (1m/s to 2m/s) offshore wind during the early hours of the morning, which reduces and becomes a stronger onshore wind as the land heats up during the warmer months of the year. This thermal influence, coupled with the meteorological dynamics of the region, can result in strong winds occurring with little forewarning.

Figure 6.2 shows a wind rose compiled from data collected during 2007 at Sangachal Terminal and supplemented by data from Baku Airport for the year (2007)<sup>4</sup>. The predominant wind direction is north occurring approximately 15% of the year. North-northwesterly and north-northeasterly winds account for approximately 10-12% of other winds. Wind speeds typically range from 0.5m/s to 12m/s with approximately 30% of winds being greater than 8m/s.

**Figure 6.2 Annual Wind Rose (Sangachal Terminal), 2007**

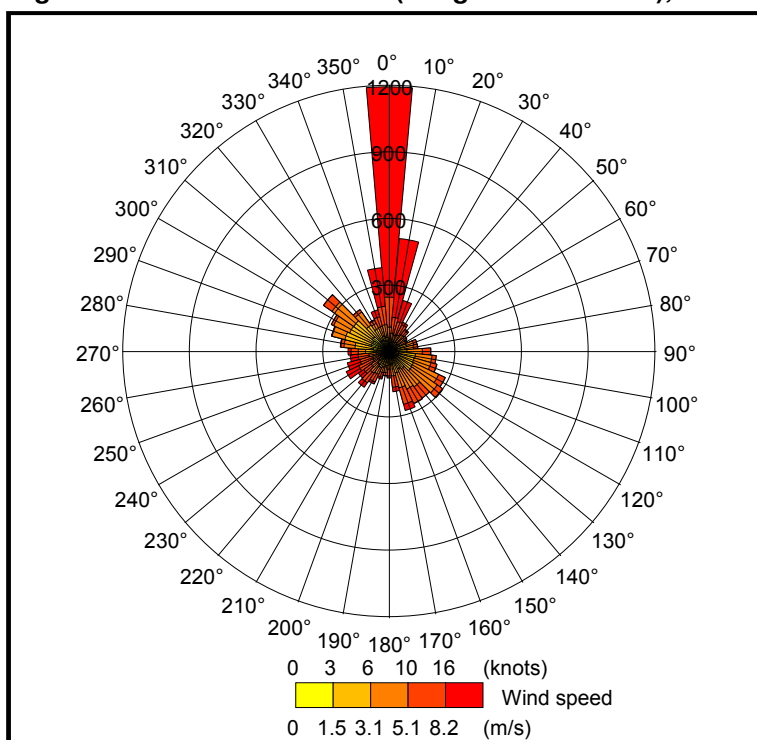

## 6.4 Terrestrial Environment

### 6.4.1 Setting

The Terminal, occupying an area of approximately 5.5km<sup>2</sup>, is sited on a plain sloping gently towards the south east and to the Caspian Sea. The elevation of the Terminal site is around 15m to 20m below Mean Sea Level (MSL) (the mean level of the Caspian Sea is about 27 to 28m below MSL). There are a number of steeper hills to the north and north east of the Terminal rising to over 300m to the north and 400m around Mount (Mt) Qaraqush, a large mud volcano, which last erupted in 2000. The nearest hills lie to the northwest with a mean height of 70m to 85m above MSL.

<sup>4</sup> The anemometer is located 10m above ground level

There are four main settlements in the vicinity of the Terminal (Figure 6.1) the largest being Sangachal Town located approximately 2.5km south. The Umid Settlement lies less than 1km to the east of the Terminal, and Azim Kend and Masiv 3 are located approximately 2.7km to the southwest.

Umid and Sangachal Town are adjacent to the Baku-Salyan Highway, a four lane hard-surfaced road that runs parallel to the Caspian Sea coastline. A raised railway line (2m to 4m above ground level) runs parallel to the highway, between the highway and the Terminal. Multiple underground and aboveground pipelines (oil, water and gas pipelines) also run parallel to the highway between the railway and Terminal.

Other nearby industrial developments includes the state-owned power station located between the Terminal and Sangachal Town which started operation at the end of 2008. The Sangachal Power Station has been designed to produce electricity using generators powered by gas combustion with the option of using heavy fuel oil.

Water courses in the Terminal vicinity include:

- Shachkaiya Wadi - Flows from the Shachkaiya hills north of the Terminal and passes to the west of the Terminal area towards the Caspian Sea; and
- Umid Wadi - Located east of the Terminal.

A drainage channel has been constructed around the northern, western and eastern perimeters of the Terminal to protect it from potential flooding. The channel diverts floodwaters into existing natural drainage lines which exist between the Terminal and the Caspian Sea.

The SD2 Infrastructure area to the west and southwest of the Terminal (refer to Figure 6.1) is generally flat and includes areas (closer to the Terminal boundary) which have undergone significant disturbance associated with earlier Terminal construction works. This has resulted in the creation of two significant spoil heaps located in this area. Towards the south of the SD2 Infrastructure area, land which has been disturbed by works within the existing pipeline corridor, is often waterlogged due to poor drainage (see Section 6.4.2 below), slopes towards the Caspian Sea.

## 6.4.2 Hydrology

The hydrology of the Terminal area is complex due to its position within a number of drainage catchment areas (refer to Figure 6.3) which are:

- Shachkaiya catchment areas (the Shachkaiya Wadi and its western tributaries);
- Northern and western perimeter catchment areas;
- Flood storage areas between the Terminal and railway embankment;
- Mt Qaraqush catchment areas which comprise:
  - Western Qaraqush slopes and north east perimeter channel;
  - Central Qaraqush slopes and Umid Wadi outlet; and
  - Eastern Qaraqush slopes and rubbish dump draining towards Primorsk.

The above main catchment areas have been divided into 23 sub-catchment areas to allow the drainage of the Terminal to be characterised in a detailed hydraulic model<sup>5</sup>. The Terminal is directly affected by runoff from sub-catchments 'nw1', 'nw2' and 'nw3' to the west and northwest and 'q81', 'q9' and 'q91' which lie to the northeast and east of the Terminal (refer to Figure 6.3). Catchments 'q7', 'q8' and 'q82' drain the western slopes of Mt Qaraqush and enter flood storage area 'RES2' through culverts beneath the existing Terminal access road.

<sup>5</sup> Refer to Appendix 9E: Hydrological Modelling of this ESIA



**Figure 6.3 Main Drainage Catchment Areas in the Vicinity of the Terminal**

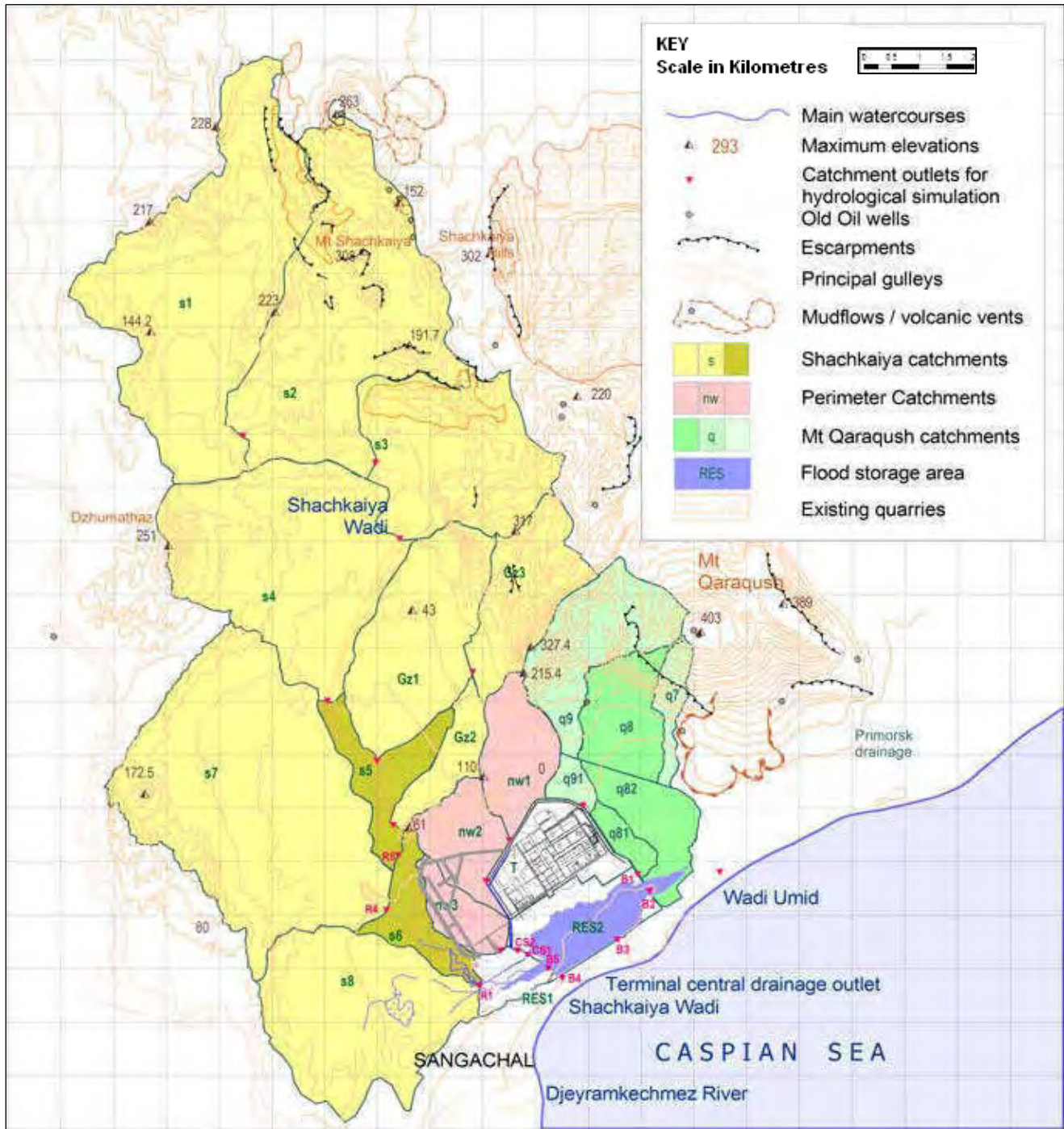

© Water Resource Associates Ltd. Based on Soviet mapping at 1:50,000 scale, with WRA data added.

The Shachkaiya Wadi and its tributaries comprise 77% of the total drainage area of 137km<sup>2</sup>. The wadi flows into the Caspian Sea via 'RES1' through bridges 'B4' and 'B3' (refer to Figure 6.3) beneath the railway embankment east of Sangachal Town, and then continues through culverts beneath the coastal highway. Outflows from sub-catchments 'nw1', 'nw2' and 'nw3' join the lower Shachkaiya Wadi channel in a low lying area which includes a complex system of over-ground pipes, ditches and spoil heaps.

The lower reaches of the Shachkaiya Wadi are usually wet and appear to have a small permanent water flow which sustains a significant area of reed, scrub and other marsh vegetation. It is likely that this flow is a combination of ephemeral surface drainage from the

Terminal and, also, waste water streams from Azim Kend, Masiv 3 and Sangachal Town with possibly a small additional contribution from leaking water supply pipes<sup>6</sup>.

The existing flood protection drainage channel around the Terminal is designed to divert floodwaters towards the Caspian Sea to the east. The northern arm of this flood protection drainage channel carries a small, but steady, stream of water which is understood to be partly derived from treated sewage effluent discharges generated at the Terminal. No flow has been observed in the channel to the west during dry weather periods.

Flows from 'RES1' into 'RES2' combine with stormwater drainage water from the Terminal and also from the northern and eastern perimeter channels. The combined flow drains beneath the railway embankment at bridge 'B3' and under the coastal highway through a culvert towards the Caspian Sea.

Field inspections and hydrological modelling have suggested that soils within the catchment area are relatively impermeable. A 'baked crust' is created and maintained by the cyclic process of rainfall and drying which impedes infiltration during storm events. Approximately 50% of the rainfall landing on the soil runs off during floods, and the wadis respond rapidly to rainfall.

A number of ephemeral streams surrounding the Terminal have the potential to cause flooding. While these streams do not flow all year round, they can carry significant volumes of flood runoff following short-duration, intense storms.

Hydrological modelling undertaken (refer to Appendix 9E) used a combination of statistical analysis of annual maximum flows from river gauging stations, local-rainfall data and a unit hydrograph approach to estimate flood hydrographs and runoff volumes.

The Shachkaiya Wadi and flood protection drainage channel has been hydraulically modelled as a linear flood corridor with three spill sections which allow water to move out the flood protection drainage channel and into a floodplain storage area. Water is shown to pond behind the old railway embankment between Sangachal Power Station and the Terminal ('RES1'), before moving into a large storage area formed by construction of the main railway line ('RES2'). Finally, water enters a narrow strip of low-lying land between the railway and Baku-Salyan Highway which offers further floodwater storage. There is a total floodwater storage capacity of more than 3 Mm<sup>3</sup> in the three areas of floodplain.

## Sensitivity

The existing drainage route from the Terminal to the Caspian Sea reflects many years of modification by human activities, in particular the laying of third-party pipelines and earthmoving activities for road and railway construction activities. Hydrological modelling undertaken in 2002 demonstrated that the design capacity of the Terminal drainage channel and associated culverts were sufficient to accommodate flows from a 1 in 100 year, 18-hour flood event (major flood event). However, the potential for silt deposition to affect the drainage route and an increase in the area subject to ponding during high rainfall was identified.

The recent hydrological modelling (see Appendix 9E) confirmed that Sangachal Town and Sangachal Power Station are sited on elevated ground and would be unaffected by a major flood event.

A Caravanserai is located approximately 960m east from Sangachal Town and set back approximately 80m from the highway towards the Terminal (refer to Section 6.6). The land where it is located is at an average elevation of -20.1 m above MSL, reducing to an elevation of -21.2 mMSL at the lowest point within the Caravanserai complex. This lowest level lies just above the modelled major 100 year flood event level of -21.3 mMSL in this location. There are a number of uncertainties within the modelling<sup>7</sup> and it is therefore considered that some parts of the Caravanserai are likely to be at risk of shallow flooding from a major event.

<sup>6</sup> Presence of leaking water pipes confirmed during walkover in June 2011

<sup>7</sup> Uncertainties are associated with the model input data and the inherent uncertainties in the model itself – refer to Appendix 9E

The effect of a major flood event on the Baku-Salyan Highway was also modelled. It was shown that the highway would be affected by flooding at culvert 'B6' which is located about 1km east of the road to Sangachal from the highway. During the major flood event, water would surcharge the box culverts at this point and flow over the highway.

The large volumes of flood water that currently reach the central storage area, 'RES2', drain through bridge 'B3' under the railway embankment. Under present conditions, modelling showed that for the 100 year flood a 250m length of the railway track at this point could be flooded to a depth of up to 0.26m across the rails and up to 0.87m across the ballast. Such overtopping might cause scour of the railway embankment and possible failure, risking damage to both the railway line and to the coastal highway with a large volume of sediment laden water having the potential to cause significant damage.

### 6.4.3 Geology, Soils and Historical Pollution

A number of boreholes have been drilled since 1995 to investigate soil and groundwater quality. The locations of boreholes included within the 2006 and 2008 monitoring programme are illustrated in Figure 6.4<sup>8</sup>. A number of these boreholes were re-sampled in 2010 and are discussed below, where relevant.

**Figure 6.4 Locations of Abandoned Exploratory Drilling Wells and Position of Soil and Groundwater Monitoring Boreholes**

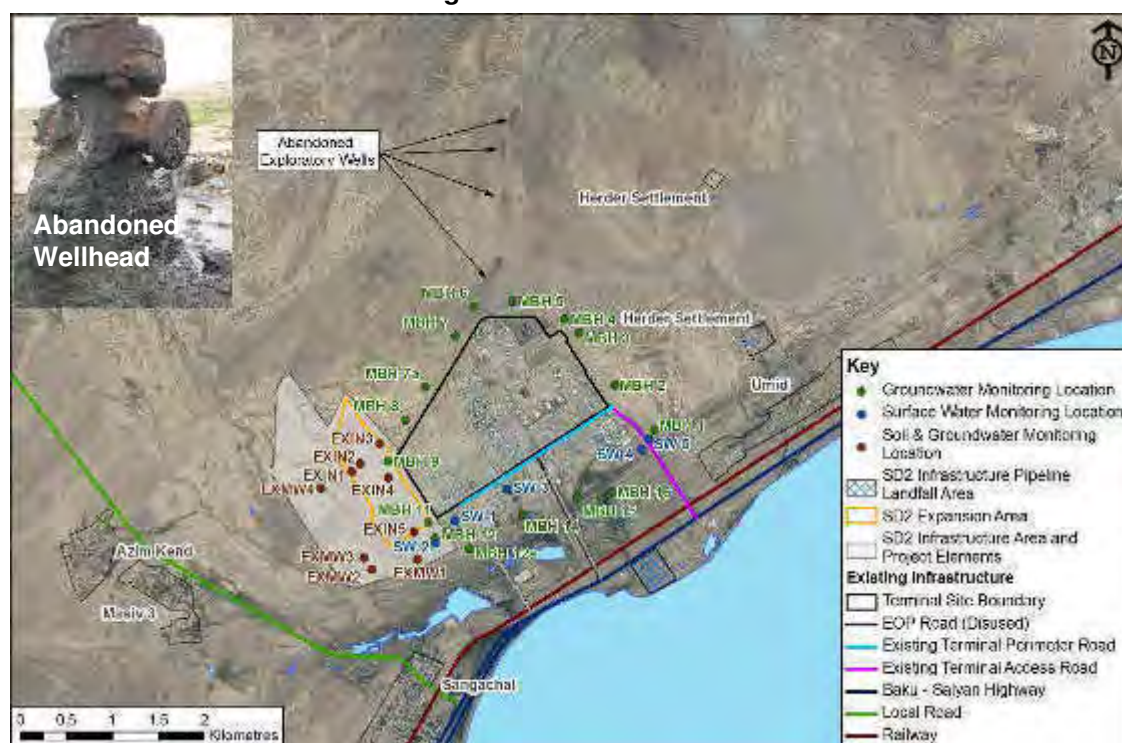

In general terms, while the surveys have indicated that strata underlying the Terminal and the adjacent SD2 Infrastructure area is characterised by low permeability estuarine clays, water does still permeate through it. Regional geological conditions suggests that the strata continue to a depth of 50m, however, the results of borehole drilling have only proven estuarine clays down to a depth of 20m.

Subsurface geology recorded by the 2006 survey indicates that strata comprises stiff to very stiff, light brown to brown, laminated clayey-silt sequence with occasional seams of fine to medium grained sands which vary in thickness.

<sup>8</sup> Note that EXIN wells are no longer monitored.



Analysis of soil samples collected during the 2006 survey indicate that Total Petroleum Hydrocarbon (TPH) was present at various depths from all boreholes, up to a maximum concentration of 91 mg/kg at MBH5 collected at a depth of 18-19m. The boreholes located close to, or within, the SD2 Infrastructure area (MBH6, MBH9, MBH11, MBH12 and MBH12a) indicate that TPH is greatest at a depth of 8 to 12m.

The presence of four abandoned exploratory wells to the north of the Terminal can clearly be identified in Figure 6.4 (abandoned wellhead also shown) where surface staining is visible from each well location. Surface staining is observed continuing down the topographic slope towards the northern boundary of the Terminal. The source of TPH concentrations across areas investigated in 2006 are likely to be linked to previous Soviet era hydrocarbon exploration activities.

The analytical results of the 2008 survey completed within the SD2 Infrastructure area (EXMW and EXIN boreholes within Figure 6.4) are summarised within Table 6.3.

**Table 6.3 SD2 Infrastructure Area Soil Sample Results, 2008**

Parameter (mg/kg)	Monitoring Wells				Boreholes					Standard (mg/kg)	Standard Reference
	EXMW1	EXMW2	EXMW3	EXMW4	EXIN1	EXIN2	EXIN3	EXIN4	EXIN5		
TPH	4.5	14.4	4.3	<2.5	-	-	-	-	-	5,000	
Arsenic	2.9	8.4	5.2	7.7	10.0	15.3	7.7	11.1	9.8	1.6	USEPA RSL
Barium	246	250	252	254	376	578	172	510	312	22,000	UK
Cadmium	0.17	0.22	0.17	0.16	0.39	0.24	0.29	0.28	0.26	230	UK
Chromium	49.4	42.8	52.3	49.8	67.2	66.7	62.0	107	60.8	8,840	UK
Copper	36.5	22.9	26.8	27.9	45.3	43.4	33.9	54.9	32.3	41,000	USEPA RSL
Iron	28,900	25,800	2,800	30,100	35,000	40,700	31,800	50,800	32,800	720,000	USEPA RSL
Lead	22.6	15.9	17.8	18.0	14.4	20.4	12.1	23.4	15.5	800	USEPA RSL
Mercury	0.04	0.03	0.04	0.03	0.04	0.04	0.05	0.05	0.04	310	USEPA RSL
Zinc	64.0	60	68.4	68.0	83.5	92.4	68.7	113	76.7	310,000	USEPA RSL

Analysis of soil samples collected from the 2008 boreholes indicates:

- Arsenic concentrations in soil exceeded the USEPA Regional Screening Level (RSL) across all the EXMW and EXIN boreholes (Figure 6.4 and Table 6.3) that lie to the west of the Terminal. High Arsenic concentrations appear to be naturally occurring within soils across the region and are not linked to operations at the Terminal;
- High concentrations of iron in soil were detected which are typical of general soil conditions;
- TPH concentrations were generally low; and
- Results from the analysis of Conductivity, Carbonate content, Gypsum, pH and Total Organic Carbon (TOC) within soil were within normal ranges expected for the saline soils which are typically found in the vicinity of the Terminal.

### Sensitivity

The existing data on geology and soils indicates strata across the Terminal and SD2 Infrastructure area exhibits a low permeability which results in groundwater having a low vulnerability from surface spills and leaks of hazardous substances.

The level of pollution detected by the 2006 and 2008 surveys indicate that there has not been a significant impact to soil quality from previous Soviet era hydrocarbon exploration activities. Surveys indicate that to date, activities at the Terminal have not impacted the quality of soil at the locations investigated.

## 6.4.4 Groundwater and Surface Water

### Groundwater

The quality of groundwater and surface water was investigated by the 2006 and 2008 surveys (Table 6.1). Groundwater is expected to be present in small quantities within the occasional seams of fine to medium grained sands which are known to vary in thickness, although there is no significant groundwater-bearing unit within a depth of 20m.

From the 2006 survey, groundwater was present at only 7 monitoring well locations:

- North of the Terminal (MBH4, MBH5, MBH6 and MBH7); and
- South of the Terminal along the 3rd party corridor route (MBH12, MBH14 and MBH16).

The highest TPH value in groundwater in the 2006 survey was recorded from 122µg/l (MBH7) to the north of the Terminal.

Groundwater was only detected in 2 monitoring wells during the 2008 survey within the SD2 Infrastructure area: EXMW1 and EXMW3. TPH and heavy metal concentrations within groundwater in each location were all below criterion limits (refer to Table 6.4).

**Table 6.4 TPH and Heavy Metal Results of Groundwater Samples from 2008 Survey**

Parameter	EXMW1	EXMW3
TPH (µg/l)	21	99
<i>Heavy metals (mg/l):</i>		
Arsenic	0.11	0.01
Cadmium	0.003	0.009
Chromium	0.04	0.07
Copper	0.10	0.12
Iron	67.5	53.2
Mercury	0.00006	0.000012
Manganese	2.5	2.7
Nickel	0.08	0.09
Lead	0.16	0.17
Selenium	<0.005	<0.005
Zinc	0.11	0.01

The 2008 water quality data indicates that concentrations of heavy metals for Cadmium, Copper, Iron, Manganese, Nickel, and Lead all exceeded USEPA criterion values. The source of these heavy metals is not known, however levels of Chromium, Copper, Mercury, Manganese, Nickel and Lead recorded in 2010 at EXMW1 were all lower than those recorded in 2008 by between 6 (Mercury) to 1,000 times (Manganese).

### Surface Water

A total of five surface water samples were collected in 2006 to the south of the Terminal and analysed for TPH, BTEX compounds (benzene, toluene, ethylbenzene, and xylenes), PAH (polyaromatic hydrocarbons) and heavy metals. All samples exceeded US EPA drinking water standards for TPH and zinc was exceeded at SW5, however the concentration is abnormally high compared with other results and may be a result of contamination of the sample or laboratory error. Small concentrations of BTEX compounds were detected in SW3 and PAH exceeded USEPA criterion values in SW4 (refer to Table 6.5).

**Table 6.5 Results of Surface Water Samples from 2006 Survey**

Parameter	SW1	SW2	SW3	SW4	SW5
TPH (µg/l)	113	297	40	280	65
BTEX (mg/l)	<0.02	<0.02	0.462	<0.02	<0.02
16 PAH (total) (µg/l)	0.016	0.016	0.117	0.353	0.098
Arsenic	<5	<5	<5	<5	<5
Barium	18	41	144	30	52
Cadmium	<1	<1	<1	<1	<1
Chromium	<10	<10	<10	<10	<10
Copper	8	3	3	<1	2
Iron	<10	<10	11	<10	14
Mercury	0.014	0.011	0.011	0.020	0.011
Lead	<10	<10	<10	<10	<10
Zinc	<10	<10	<10	<10	7,860

## Wetland

Water and soil quality within reedbeds located in the wetlands have been investigated by surveys completed in 2002 and 2010. Water samples collected in 2002 indicated high levels of cadmium, PAH and THC from the reedbeds. Soil samples collected from the same location also featured high levels of THC, PAH and phenols.

A comparison of the 2002 and 2010 data indicates that the concentration of the following key parameters has changed:

- Cadmium in water has decreased from 0.43 mg/l to less than 0.001mg/l;
- THC in water has decreased from 217 µg/l to 28 µg/l;
- PAH in soil has remained at a similar level; 120 µg/kg and 85 µg/kg in 2002 and 2010 respectively; and
- THC in soil has remained at a similar level; 63 µg/kg and 66 µg/kg in 2002 and 2010, respectively.

A walkover of the wetlands undertaken in June 2011 identified a number of spills within the wetland area (refer to Figure 6.5).

**Figure 6.5 Observed Spills in Wetland Vicinity, June 2011**



Further water and soil quality surveys are planned to characterise the spills (including, where possible, identifying the source of the spill) and determine the extent of any contamination. From observation, all spills appeared to be hydrocarbon with the surface of some areas covered with weathered crude. The majority of the observed hydrocarbons appeared to originate from a large spill at 'RES1' which was traced through 'RES2' to the outfall at 'B3' (Figure 6.3). Other spills occurred in the vicinity of pipelines, however no visible leaks were observed.

## Sensitivity

**Groundwater:** There is no substantial groundwater-bearing unit within 20m below ground surface. The survey results to date indicate previous hydrocarbon exploration activities have not resulted in a significant impact to groundwater quality.

**Surface water:** TPH concentrations (40 to 290 µg/l) are in the same magnitude as TPH recorded in groundwater (highest at MBH7 122µg/l).

**Wetlands:** The results of the 2002 and 2010 water and soil quality surveys indicate that the wetland area is characterised by high concentrations of some heavy metals and hydrocarbons within both soil and groundwater. Whilst the overall quality of groundwater within the wetland area was shown to have improved between the 2002 and 2010 survey, PAH levels in soil were shown to have slightly increased. The walkover survey undertaken in 2011 recorded a number of hydrocarbon spills, suggesting potential areas of contamination in the wetland.

### 6.4.5 Air Quality

Ambient air quality monitoring has been undertaken around the Terminal since 1997, prior to the EOP activities commencing at the Terminal. The monitoring locations, parameters recorded and analytical methodology used has varied across the monitoring surveys. The most recent air quality monitoring surveys were undertaken during 2009 and 2010.

Concentrations of SO<sub>x</sub>, benzene, VOC and NO<sub>2</sub> were monitored at seventeen locations using passive diffusion tubes. Hourly real-time monitoring data (for NO, NO<sub>2</sub>, NO<sub>x</sub>, SO<sub>2</sub> and PM<sub>10</sub>) was also collected at an automatic monitoring station (station AAQ23) between February - May 2009 and May - December 2010<sup>9</sup>. Odour monitoring was also undertaken in 2010 based on a “sniff test” approach as recommended by UK Environment Agency Guidance<sup>10</sup>.

Figure 6.6 presents the location of monitoring stations used in the 2009 and 2010 air quality and odour surveys. The figure also shows the location of the Sangachal Power Station which commenced operation in December 2008. It is understood the Sangachal Power Station is designed to be primarily gas fired.

**Figure 6.6 Ambient Air Quality (2009 & 2010) and Odour Monitoring Locations (2010)**



<sup>9</sup> Interruptions to the monitoring station power supply prevented further data from being obtained.

<sup>10</sup> Odour monitoring was undertaken separately to the 2010 air quality monitoring and does not form part of the IEMP.



Ambient air quality measurements were assessed against IFC<sup>11</sup> and World Health Organisation Guidelines<sup>12</sup> (WHO), and in the case of benzene, the European Union (EU) Guidelines.<sup>13,14,15</sup>

### NO<sub>2</sub> Concentrations

Measured NO<sub>2</sub> concentrations are shown in Table 6.6, based on three rounds of monitoring in 2009 and four rounds of monitoring in 2010. The table also includes the automatic monitoring station data recorded in 2009 and 2010 (location AAQ23).

**Table 6.6 Average NO<sub>2</sub> Air Quality Concentrations, 2009 and 2010 (µg/m<sup>3</sup>)**

Monitoring Location	Diffusion Tube Survey Results		Automatic Monitoring Station Results			
	2009 Concentration (av. of 3 rounds)	2010 Concentration (av. of 4 rounds)	February - May 2009	May-December 2010		
AAQ 6	14.0	13.5	n/a	n/a		
AAQ 7	11.7	12.3				
AAQ 8	10.1	9.5				
AAQ 9	7.8	8.7				
AAQ 10	9.0	10.2				
AAQ 11	3.6	3.9				
AAQ 12	7.7	9.5				
AAQ 13	19.1	12.0 <sup>1</sup>				
AAQ 14	3.9	6.4				
AAQ 15	4.0	4.8				
AAQ 16	3.8	3.9				
AAQ 17	4.8	2.4				
AAQ 18	5.4	7.8				
AAQ 19	4.9	4.6				
AAQ 20	5.5	9.2				
AAQ 21	11.2	10.2				
AAQ 22	10.3	8.9				
AAQ 23	NA	18.7 <sup>2</sup>			22 <sup>3</sup>	33 <sup>3</sup>
Applicable Limit	40 µg/m <sup>3</sup> (annual average) <sup>4</sup>	40 µg/m <sup>3</sup> (annual average) <sup>4</sup>			200 µg/m <sup>3</sup> (1 hour average) <sup>5</sup> 150 µg/m <sup>3</sup> (24 hour average) <sup>6</sup>	

<sup>1</sup> Only one round of results was available at AAQ13 in 2010. <sup>2</sup> 2010 survey included diffusion tube monitoring at the AAQ23 location. <sup>3</sup> Average of 1 hour results obtained over sampling period. <sup>4</sup> EU/WHO/IFC annual average standard. <sup>5</sup> EU/IFC 1 hour average standard. <sup>6</sup> WHO maximum 24 hour average standard.

Annual average limit values for NO<sub>2</sub> were not exceeded at any of the diffusion tube stations. Concentrations ranged between 6% and 48% of the annual average air quality standard for NO<sub>2</sub>, with the highest concentration reported in 2009 at station AAQ13, situated approximately 0.75km south of the existing Terminal and approximately 1km to the northeast of Sangachal Power Station. Average hourly concentrations recorded at the automatic monitoring station during 2009 and 2010 did not exceed the relevant 1 hour average and 24 hour limit values.

### SO<sub>2</sub> Concentrations

The measured SO<sub>2</sub> concentrations in 2009 and 2010, based on four rounds of monitoring each year, are shown in Table 6.7.

<sup>11</sup> IFC Environmental, Health and Safety Guidelines. General EHS Guidelines: Environmental, Air Emissions and Ambient Air Quality (2007).

<sup>12</sup> World Health Organisation Guidelines (1999).

<sup>13</sup> European Union Guidelines (2005).

<sup>14</sup> No guidelines were available for total VOC.

<sup>15</sup> Historically in Azerbaijan ambient concentrations of NO<sub>2</sub>, SO<sub>2</sub>, CO and PM<sub>10</sub> have also been assessed against 24 hour and 1 hour standards. These standards were not derived using the same health based criteria as the IFC, WHO and EU guideline values and the standards derived are not widely recognised.



**Table 6.7 Average SO<sub>2</sub> Air Quality Concentrations, 2009 and 2010 (µg/m<sup>3</sup>)**

Monitoring Location	Diffusion Tube Survey results		Automatic monitoring station results			
	2009 Concentration (av. of 4 rounds)	2010 Concentration (av. of 4 rounds)	February - May 2009	May-December 2010		
AAQ 6	10.0	11.2	n/a	n/a		
AAQ 7	7.6	3.6				
AAQ 8	3.3	5.1				
AAQ 9	9.0	4.2				
AAQ 10	3.5	4.4				
AAQ 11	1.8	21.6				
AAQ 12	8.5	4.7				
AAQ 13	3.3	1,100 <sup>1</sup>				
AAQ 14	2.3	5.3				
AAQ 15	0.8	5.0				
AAQ 16	0.8	13.9				
AAQ 17	2.1	11.9				
AAQ 18	0.9	3.1				
AAQ 19	4.7	3.0				
AAQ 20	2.1	10.7				
AAQ 21	5.3	1.7				
AAQ 22	0.8	5.7				
AAQ 23	NA	7.3 <sup>2</sup>			2 <sup>3</sup>	4 <sup>3</sup>
Applicable Limit	50 µg/m <sup>3</sup> (annual average) <sup>4</sup>				125 (max. 24 hour average) <sup>5</sup>	

<sup>1</sup> Only one round of results was available at AAQ13 in 2010. <sup>2</sup> 2010 survey included diffusion tube monitoring at the AAQ23 location. <sup>3</sup> Average of 1 hour results obtained over sampling period. <sup>4</sup> Former World Bank annual average standard. <sup>5</sup> EU/WHO/IFC maximum 24hr average.

The annual average air quality standard for SO<sub>2</sub> was not exceeded at any station in 2009. Concentrations ranged between 1% and 20% of the applicable air quality standard, with the highest concentration (10.0µg/m<sup>3</sup>) reported at station AAQ6 (adjacent to the Sangachal Power Station). No exceedances were recorded at the automatic monitoring station during 2009 (AAQ23).

The annual average standard for SO<sub>2</sub> was exceeded at one monitoring station in 2010 (AAQ13) although the use of just one round of monitoring data is not considered representative of annual average conditions. The measured concentration at AAQ13 is also abnormally high compared with other results and may be a result of contamination of the sample or laboratory error. No other exceedance of the annual average standard was recorded at any of the monitoring locations, or during any of the monitoring rounds during 2009 and 2010. In addition, no exceedances of the 24 hour average limit were recorded at the automatic monitoring station during 2010.

### Benzene and VOC Concentrations

The measured benzene and total Volatile Organic Carbon (VOC) concentrations for 2009 and 2010 are shown in Table 6.8.

**Table 6.8 Average Benzene and VOC Concentrations, 2009 and 2010 (µg/m<sup>3</sup>)**

Monitoring Location	Benzene (2009)	Benzene (2010)	VOC (2009)	VOC (2010)
AAQ 6	9.1 <sup>3</sup>	6.4 <sup>1</sup>	297	209
AAQ 7	20.8 <sup>3</sup>	68.3 <sup>3</sup>	687	1,858
AAQ 8	2.1	3.4	69	85
AAQ 9	3.7 <sup>2</sup>	3.1	93	87
AAQ 10	4.1 <sup>2</sup>	2.8	102	86
AAQ 11	2.2	2.4	45	68
AAQ 12	3.4 <sup>2</sup>	3.8 <sup>1</sup>	205	241
AAQ 13	3.6 <sup>2</sup>	2.8 <sup>4</sup>	132	73 <sup>4</sup>
AAQ 14	3.3	2.7	64	57
AAQ 15	3.1	2.3	56	52
AAQ 16	3.5	3.5	62	45
AAQ 17	2.6	1.8	46	41
AAQ 18	4.0	2.6	128	65
AAQ 19	2.9	2.4	39	46
AAQ 20	8.0 <sup>1</sup>	4.0 <sup>1</sup>	672	273
AAQ 21	2.5	2.3	95	86
AAQ 22	4.4 <sup>1</sup>	4.7 <sup>2</sup>	120	143
AAQ23	NA	3.5 <sup>5</sup>	NA	90 <sup>5</sup>
Applicable Limit	5 µg/m <sup>3</sup> (annual average) <sup>6</sup>		-	-

<sup>1</sup> One of the rounds of results exceeded the applicable limit. <sup>2</sup> Two or three rounds of results exceeded the applicable limit. <sup>3</sup> Each of the four rounds of results exceeded the applicable limit. <sup>4</sup> Only one round of results was available at AAQ13 in 2010. <sup>5</sup> 2010 survey included diffusion tube monitoring at the AAQ23 location. <sup>6</sup> EU annual average standard.

The average 2009 concentration of benzene and VOC ranged between 2.1 - 20.8  $\mu\text{g}/\text{m}^3$  and 39 - 687  $\mu\text{g}/\text{m}^3$  respectively. The highest benzene measurements were recorded at AAQ7, a monitoring location within Sangachal Town. The annual average air quality standard for benzene was exceeded at three locations during 2009: AAQ6, AAQ7 and AAQ20. The standard was also exceeded during individual measurement rounds at 6 other stations. This does not infer a breach of the limits as the annual mean concentration at these 6 locations complied with the standard.

Of the three stations where the annual average concentrations exceeded the air quality standard, one is located within Sangachal Town (AAQ7), with the other two situated between Sangachal Town and the Terminal (AAQ6, AAQ20), as shown in Figure 6.7. Monitoring station AAQ22 is situated close to these stations and only narrowly complied with the air quality standard for benzene. Stations closer to the Terminal (e.g. AAQ13 and AAQ14) however, complied with the applicable limits.

The average 2010 concentrations for benzene and VOC ranged between 1.8 - 68.3  $\mu\text{g}/\text{m}^3$  and 41 - 1858  $\mu\text{g}/\text{m}^3$  respectively. The highest benzene measurements were again recorded at AAQ7. The consistently high concentrations recorded at AAQ7 indicate it is very likely that a local emission source is influencing benzene and VOC results at this location.

The air quality standard for benzene was exceeded at two locations according to 2010 monitoring data: AAQ6 and AAQ7. Exceedances were recorded during individual measurement rounds at 3 other stations, though this does not infer a breach of the limits as the mean annual concentrations at these 3 locations complied with the relevant limit.

Concentrations of benzene and VOCs are consistently higher at locations in, and adjacent to, Sangachal Town (AAQ6, AAQ7 and AAQ22) and at AAQ20 which lies immediately downwind of the Terminal. Concentrations at AA23 (in 2010), which is also located within Sangachal Town, were not elevated.

An odour assessment was undertaken in 2010 along the Terminal boundary and in locations within the four communities surrounding the Terminal (see Figure 6.7). The primary odour detected was a tarry, oily smell from the Terminal produced water ponds, which are located to the north eastern of the Terminal. The odour was reported to be strong around the produced water ponds (locations T1, T2 and T3) and faintly detectable (under northeasterly wind conditions) at Sangachal Town (location C3). It is possible that evaporation of volatile compounds from produced water ponds may contribute to the high benzene and VOC concentrations recorded downwind of the Terminal. Odours that are associated with nearby farming activities were detected at location C2.

### PM<sub>10</sub> Concentrations

The measured PM<sub>10</sub> concentrations for 2009 and 2010 are shown in Table 6.9. Results were obtained from the automatic monitoring station (location AAQ23).

**Table 6.9 PM<sub>10</sub> Concentrations, 2009 and 2010 ( $\mu\text{g}/\text{m}^3$ )**

Month	PM <sub>10</sub> Concentrations ( $\mu\text{g}/\text{m}^3$ )	
	2009	2010
February	102	-
March	52	-
April	26	-
May	115	51
June	-	56
July	-	33
August	-	125
September	-	146
October	-	118
November	-	160
December	-	180
<i>Average</i>	74	109
<i>Applicable Limits</i>	40 $\mu\text{g}/\text{m}^3$ (annual average) <sup>1</sup> , 50 $\mu\text{g}/\text{m}^3$ (24 hour standard) <sup>2</sup>	

1. EU annual average standard. 2. WHO, IFC and EU 24 hour standard

The average monthly PM<sub>10</sub> concentration ranged between 26 µg/m<sup>3</sup> in April 2009 and 180 µg/m<sup>3</sup> in December 2010, with considerable variance between the months, as shown in Table 6.9. The average PM<sub>10</sub> concentration for the 4-month monitoring period in 2009 was 74 µg/m<sup>3</sup> and 109 µg/m<sup>3</sup> in 2010. This exceeds the EU annual average standard of 40 µg/m<sup>3</sup>. In addition, the PM<sub>10</sub> results also exceeded the WHO, IFC and EU 24 hour standard of 50 µg/m<sup>3</sup> for all months excluding March and April 2009 and July 2010.

PM<sub>10</sub> is defined as airborne particles (i.e. dust) which have a diameter less than 10 microns (µ) and is routinely monitored for the protection of human health. In semi-arid and arid environments, ambient PM<sub>10</sub> concentrations often exceed international air quality standards regardless of the presence of local man-made activities due to the natural entrainment of dust in the atmosphere which is typical of dry, windy conditions.

The PM<sub>10</sub> results recorded in 2009 and 2010 show no clear trend although higher concentrations were recorded during winter months when wind conditions are stronger. Given the semi-arid nature of the region, it is considered likely that natural conditions are the most likely cause of the variations shown in PM<sub>10</sub> data.

### Sensitivity

Air quality concentrations have been regularly monitored at locations in the Terminal vicinity since 2006 and the results from 2009 and 2010 surveys are presented above. The results of air quality monitoring during 2006 and 2007 surveys were included in the COP ESIA<sup>16</sup>. While survey locations and methods have varied, it is possible to compare the earlier results to those obtained in 2009 and 2010. For example, NO<sub>x</sub> results at location AAQ07 range between 11 and 13 µg/m<sup>3</sup> with the exception of an anomalous result in 2007 during a period when the Terminal was shutdown.

The results for SO<sub>2</sub> concentrations in the same location have varied between 1.6 µg/m<sup>3</sup> (in 2007) and 7.6 µg/m<sup>3</sup> (in 2009). No trends indicating deteriorating air quality are evident since results in 2006 were higher than those in 2007, and the 2010 results were lower than the data recorded in 2009. There is also no trend evident from PM<sub>10</sub> data which has consistently varied throughout the available data set.

With the exception of PM<sub>10</sub> (discussed above), air quality data is consistently below applicable limit values. The data did not indicate any negative effect associated with the Sangachal Power Station as there is no significant change in air quality recorded before/after the start of operation. It is considered likely that local factors, such as the generation of dust and wind conditions, influence local air quality to a greater extent than emissions associated with operations at the Terminal and at Sangachal Power Station.

### 6.4.6 Noise

Ambient noise monitoring surveys have been completed to inform the previous ACG and SD ESIA's. The most recent surveys were completed in 2010 and 2011. The 2010 noise survey included 5 locations (R1 to R5) which are located adjacent to, or within, Azim Kend, Masiv 3, Sangachal Town and Umid.

Monitoring locations during the 2011 noise survey included:

- Sensitive receptors within local communities and recreational areas (including the 2010 R1 to R5 locations and locations R8, R11, R12, A1, A3 and A4 – refer to Table 6.10 for receptor types); and
- Locations immediately adjacent to the highway – selected to measure baseline traffic noise (R9, R10, R11 and A3).

The 2010 and 2011 monitoring locations are shown in Figure 6.7.

---

<sup>16</sup> COP ESIA, (2010)

**Figure 6.7 Noise Survey Locations, 2010 and 2011**



Table 6.10 presents the noise levels recorded (as  $LA_{eq}^{17}$ ) during daytime and night time periods at sensitive receptors and at locations adjacent to the Baku-Salyan Highway (measured as  $LA_{10}$ ).

Measurements were recorded during May 2010 and March 2011. During each survey, weather conditions were fair, with winds predominantly from the north. Monitoring results obtained when winds speeds exceeded 5m/s were excluded as, under these conditions, results are affected by wind noise.

Observations were made throughout the surveys to record the noise sources and identify dominant sources in each location. Operational data was obtained to confirm that the Terminal was operating under normal operations (i.e. there was no emergency flaring or other abnormal noise generating activity at the Terminal).

<sup>17</sup> The average ambient noise level including all potential sources (e.g. the Terminal, Sangachal Power Station, traffic, animals).

**Table 6.10 2010 and 2011 Noise Survey Results at Sensitive Receptors and Roadside Monitoring Locations**

ID	Location	Receptor	2010		2011		Traffic Noise dB LA10 (Daytime)
			Measured Ambient Noise Range (Daytime) dB LAeq	Measured Ambient Noise Range (Night Time) dB LAeq	Measured Ambient Noise Range (Daytime) dB LAeq	Measured Ambient Noise Range (Night Time) dB LAeq	
<b>Sensitive Receptors</b>							
R1	Azim Kend / Masiv 3	Low rise residences	44 – 56	46 – 48	50 - 53	39 - 51	
R2	Sangachal	Low and high rise residences	48 – 66	46 – 59	62 - 70	52 - 53	-
R3	Umid West	Low rise residences	48 – 66	49 – 53	49 - 58	45 - 55	-
R4	Umid East	Low rise residences	56 – 62	52 – 58	51- 54	*	-
R5	Sangachal Railway Crossing	Shops and low rise residences	62 – 69	49 – 59	55 - 63	*	-
R8	Azim Kend	Low rise residences	-	-	43 - 50	39 - 49	-
A1	East of Power Station	Walled residence	-	-	67 - 68	*	-
A3	North of Highway	One residence about 50m north of the highway	-	-	69	*	
A4	Beach	Amenity space	-	-	50 - 51	*	-
R11	South Side of Highway	New residential / hotel developments, some nearing completion, some still at skeleton stage	-	-	65 - 66	*	-
R12	Herder Settlement	Low rise residences	-	-	45 - 47	*	-
<b>Highway Traffic Noise Monitoring Locations</b>							
R9	South of highway – west	-	-	-	-	-	71 - 76
R10	South of Highway – middle	-	-	-	-	-	76 - 78
R11	South of highway – east	-	-	-	-	-	68 - 69
A3	North of highway – middle	-	-	-	-	-	73 - 74
Notes: *Night time noise measurements were not undertaken in this location. - Noise measurement not taken at this location.							

Daytime noise levels recorded during the 2010 and 2011 surveys reflect the movement of road traffic along the Baku-Salyan Highway. Road traffic noise from the use of local roads at Sangachal Town affected noise levels recorded at one location (R2) only. Daytime measurements did not detect noise generated from operation of the Terminal at any of the 2010 or 2011 locations.

Night time measurements in 2011 detected noise generated from operation of the Terminal at Azim Kend and Umid West. In addition, a consistent low-frequency noise could be identified at Sangachal Town and Azim Kend/Masiv 3 which was derived from the Sangachal Power Station. Night time road traffic noise from the Baku-Salyan Highway was audible at all 2010 and 2011 monitoring locations.

Both data sets for the 2010 and 2011 surveys indicate a large range in recorded dB which is typical of surveys influenced by road traffic noise. Given the range of noise levels recorded at R1 to R5 during daytime and night-time periods, there were no significant differences between noise levels recorded during the 2010 and 2011 surveys.

### Sensitivity

The noise environment within the local communities is generally quietest at night with the lowest noise levels consistently recorded at Azim Kend. During daytime and night-time periods, traffic noise (associated with the Baku Salyan Highway) is audible at all locations, resulting in significant noise levels at those locations closest to the Highway (e.g. location 'A1', 'R2', 'A3', and 'R11'). In these locations daytime noise levels are approaching and, in some cases, above the recommended noise standard of 65dB(A) (as stated within British Standard 5228<sup>18</sup>) when noise associated with construction work has the potential to impact the local community<sup>19</sup>. This guidance value differs from limit values associated with operational noise<sup>20</sup> as construction noise is recognised as being temporary and has different characteristics to operational noise. Nevertheless, the survey results show that noise levels in the locations nearest to the Highway are generally high.

Other noise sources recorded during the surveys included helicopters, animal noise and the occasional passing of construction vehicles. The noise environment at all locations is generally dominated by consistent low-mid pitch background noise.

### 6.4.7 Terrestrial Ecology

A number of habitat surveys have been undertaken in the vicinity of the Terminal since 2001. The methodology, monitoring locations and species included in the surveys has varied. Since 2006, annual spring and autumn flora surveys of the terrestrial areas surrounding the Terminal have been undertaken to identify change using ecosystem indicators. A survey was completed in 2008 which aimed to identify the status of flora and fauna within a section of the SD2 Infrastructure area. A full list of the surveys completed to date is provided in Table 6.1.

#### 6.4.7.1 Habitats

The Terminal is situated within a desert environment and comprises a complex array of bare ground, desert and semi-desert vegetation. Vegetated areas are dominated by low perennial shrubs (particularly *Salsola nodulosa*, *Salsola dendroides*, *Suaeda dendroides*, *Salsola ericoides*) interspersed with the perennial grass *Poa bulbosa*. Within the SD2 Infrastructure area, locations heavily modified by human activity are categorised as 'disturbed ground'. In addition, livestock movements and grazing has impacted the soil and vegetation in some areas surrounding the Terminal.

Results of the terrestrial monitoring survey undertaken in 2009 identified that, in general, ecological conditions improve with greater distance from the Terminal with the greatest diversity located to the west (towards the south of the SD2 Infrastructure area). Other habitat types in the areas surrounding the Terminal include chal-meadow (to the north and south of the SD2 Infrastructure area which was surveyed) associated with topographic depressions. Figure 6.8 shows the distribution of habitats around the Terminal and Figure 6.9 shows the major vegetation types in the section of the SD2 Infrastructure area included within the 2008 survey.

<sup>18</sup> BS5228:2009, 'Noise and Vibration Control on Construction and Open Sites'

<sup>19</sup> Note there is no equivalent limit value for traffic noise

<sup>20</sup> 45dB(A) during night and 55dB(A) during daytime (LA<sub>eq</sub>)



**Figure 6.8 Approximate Distributions of Plant Community Types (Habitats) Around the Terminal**

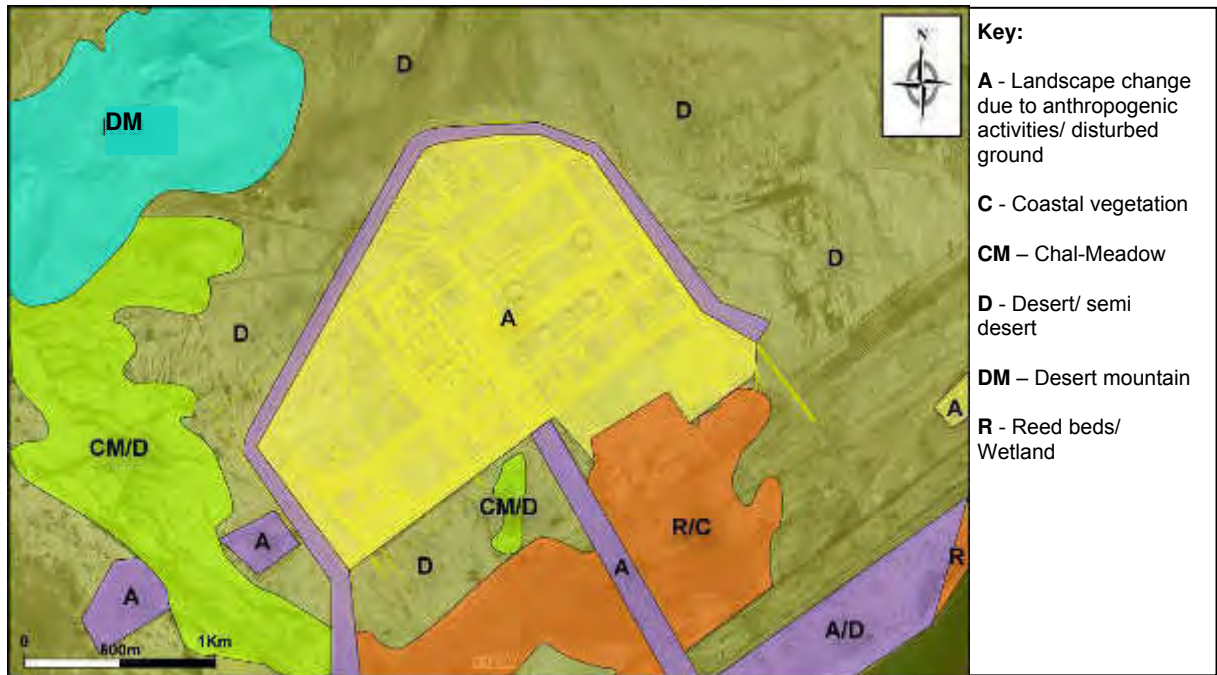

**Figure 6.9 Major Vegetation Types within SD2 Infrastructure Area (as surveyed), 2008**

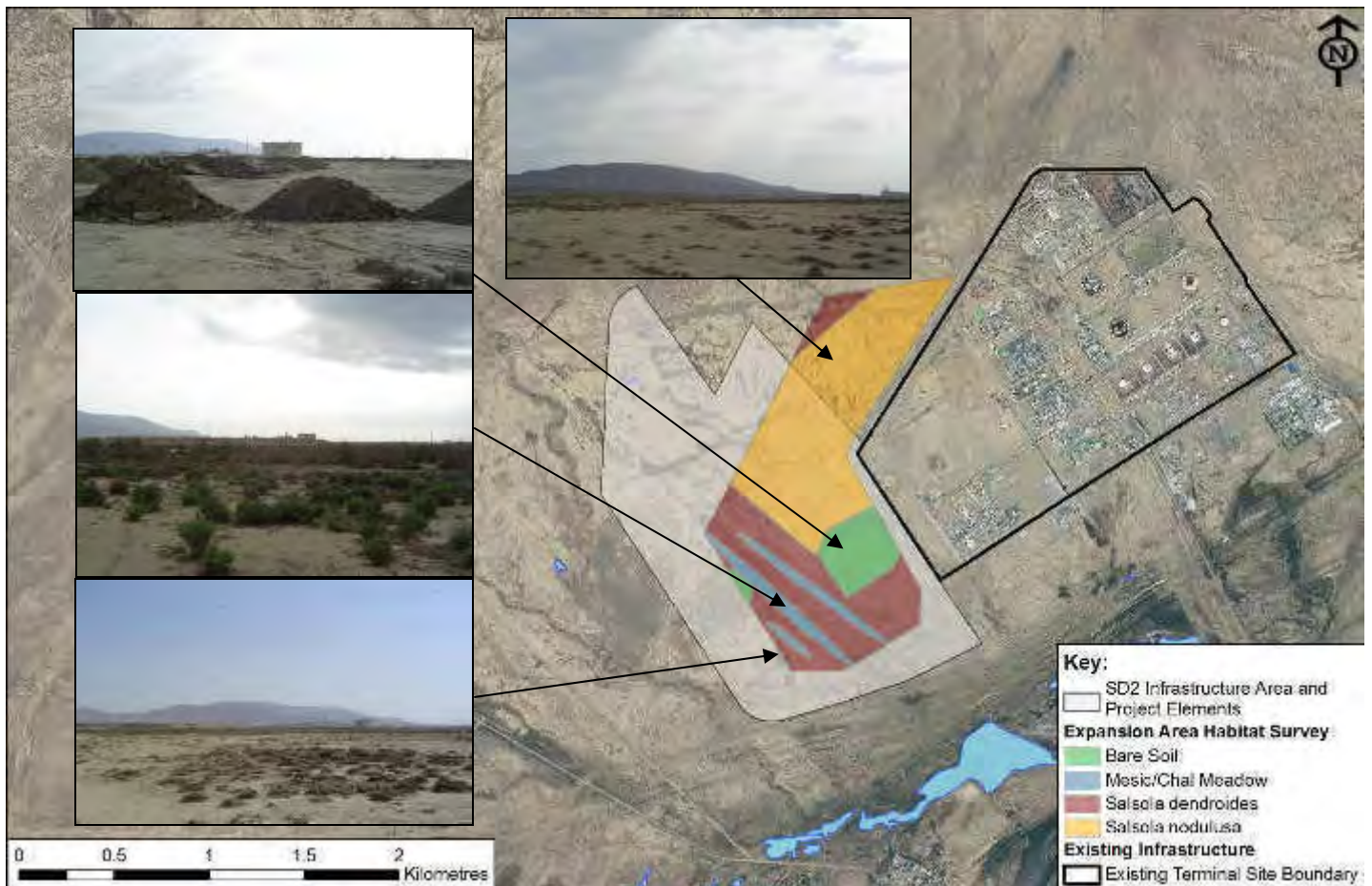

**Disturbed Ground** – Areas of disturbed ground exist primarily to the west of the Terminal and result from previous Terminal construction activities (refer to Figure 6.9 above). The 2008 survey undertaken within the SD2 Infrastructure area showed very little vegetation present in these areas. In 2005 and 2006, areas of disturbed ground were included within the terrestrial survey monitoring. Surveys were undertaken to establish the extent of re-vegetation of the areas in the period between the surveys. It was shown that regrowth was focused in locations which were previously subject to surface water ponding and more recently in areas where heavy machinery has been used. Rainwater collected in the indentation left in the ground by the machinery.

It was shown that most of the regrowth was focused at locations which were previously subject to surface water ponding or had been subject to minor changes in topography such as the indents which collect rainwater left from the use of machinery.

The results indicated that the rate of natural regeneration was generally low, with some areas featuring zero regrowth. Observations made during a site walkover in May 2011 indicated that the rate of natural regeneration within the disturbed/bare soil areas (see Figure 6.9) remains low with sparse growths of *Salsola nodulosa* and *Poa bulbosa*.

**Desert/Semi-desert** - The majority of the habitat surrounding the Terminal is desert/semi-desert. The SD2 Infrastructure area (as surveyed within 2008) comprises a variety of elements including:

- Exposed silt/bare soil;
- Silt with a growth of lichens and algae (a microbiotic crust);
- Sparse growth of perennial shrubs (desert vegetation); and
- Patches of perennial shrubs with a closed cover of grasses and annual species (semi-desert vegetation).

The extent of variation between these elements is highly variable across the SD2 Infrastructure area. The presence of a microbiotic crust encourages the germination and growth of perennial grasses by causing seeds to collect and retain surface moisture following rainfall for longer periods, when compared with areas of exposed silt. The 2001 survey provided information associated with the key species of lichens and algae which comprises the 'microbiotic crust' and included<sup>21</sup>:

- *Diploschistes gupsaceus*;
- *Squamaria lentigera*;
- *Callema crispum*;
- *Fulgensis fulgens*;
- *Toninia coeruleonigrificans*; and
- *Psora lurida*.

The main vegetation assemblages in the vicinity of the Terminal are dominated by low perennial shrubs (*Salsola nodulosa*, *Salsola dendroides*, *Suaeda dendroides*, *Salsola ericoides* and *Artemisia lerchiana*) including coastal zone variants and others in association with grasses. None of the species present identified within the desert/semi-desert habitats area is included in the Azerbaijan Red Data Book (AzRDB) or classified as vulnerable/threatened by IUCN.

The desert habitats in the SD2 Infrastructure area are generally heavily grazed, although the areas immediately surrounding the Terminal may have seen some recent reduction in grazing following the erection of a partial fence, which is not yet completed, in the west.

**Chal-Meadows** – Areas of chal-meadow are found to the west and south of the Terminal (Figure 6.8) and specifically towards the centre of the SD2 Infrastructure area as surveyed (Figure 6.9). The distribution of this vegetation community-type is linked to the temporary retention of surface water following rainfall (i.e. within depressions in the land) and comprise

<sup>21</sup> Shah Deniz Stage 1 ESIA, 2002



higher vegetative cover when compared with desert/semi-desert vegetation. Chal-meadow has a distinct species composition and is dominated by *Tamarix meyeri* scrub with, *Lycium ruthenicum*, *Alhagi pseudoalhagi*, *Hordeum leporinum* and *Medicago minima*.

**Wetland** – the primary wetland area is located to the south of the Terminal. The wetland appears to be primarily fed by ephemeral watercourses (or wadi) including the Shachkaiya Wadi which is located adjacent to the boundary of the SD2 Infrastructure area (refer to Section 6.4.2 above), together with other surface water runoff and some contribution from leakages in water pipes and discharges from Sangachal water treatment works. Wetland surveys were undertaken in 2002 (as reported within the ACG Phase 1 ESIA<sup>22</sup>) 2010 and 2011.

In general, the wetlands are considered to comprise a complex mixture of habitats, which developed following construction of the Baku-Salyan Highway, adjacent railway line and the pipeline corridor between the railway line and the Terminal. The wetlands experience high rates of siltation which has resulted in an impeded water flow that causes water to be retained across a series of topographical depressions (see Section 6.4.2). Variations in topography determine the boundaries of the wetland and the vegetation types occurring.

The main surface-water dependent habitats within the wetlands are tall reedbeds (*Phragmites australis*), which occur along the edge of the wetland closest to Sangachal, within the pipeline corridor and in other locations where deeper water occurs. In shallower permanent water, stands of reedmace (*Typha angustifolia*) and extensive marshes dominated by sea rush (*Juncus maritimus*) and sea club-rush (*Bolboschoenus maritimus*) are prominent. At the edges of the swamp/marsh areas, a scrub of Tamarisk (*Tamarix meyeri*) with alhagi (*Alhagi pseudoalhagi*) typically occurs, together with areas of mudflat, frequently colonised by glasswort (*Salicornia europaea*).

Additional habitats which occur in the wetlands include wadi channels with flat terraces that support vegetation which is similar to that of chal-meadow and includes Tamarisk shrubs (*Tamarix meyeri*) and low growing grasses (e.g. *Poa bulbosa*) and herbaceous species. Permanent pools also occur in certain locations, with vegetation such as Charophytes (aquatic multicellular algae) and water buttercup (*Ranunculus* sp.) which require permanent water.

None of the species present within the wetlands area are included in the AzRDB or classified as vulnerable/threatened by IUCN.

### Sensitivity

The monitoring surveys completed to date (between 2006 and 2010) have focused on identifying potential changes and trends in floral species present and vegetation cover.

With regard to desert/semi-desert vegetation assemblages, no significant change in their distribution or status over time has been observed. Disturbed ground has shown a poor level of natural recovery over time with faster re-vegetation observed in areas where temporary surface water has been present after rainfall events.

The surveys do indicate that there has been a change in vegetation cover within the area surrounding the Terminal. In general, the extent of plant cover appears to be increasing over time and there appears to be a decrease in the number of sites which have a measurable microbiotic crust. The reason for the decline in the abundance of microbiotic crust is not known, but it may be related to difficulty in observing the crust, given recent increases in grass cover.

Some deterioration in vegetation cover has been observed in the immediate vicinity of the Terminal where diverted runoff and construction/other activities have been ongoing during the time period covered by the surveys. Sites distant from the Terminal to the north, west, and

---

<sup>22</sup> ACG1 ESIA, 2002

southwest feature the highest quality of vegetation cover which may be related to a more favourable topography.

With the exception of physical activities e.g. earthworks, there have been no observed changes to the habitats around the Terminal as a result of the Terminal operations.

#### 6.4.7.2 Flora

As discussed above, vegetation in the Terminal vicinity is dominated by desert and semi desert vegetation. The following species however, which are included in the AzRDB or classified as vulnerable/threatened by IUCN, were noted as having been previously recorded 'in the area' (term 'area' is undefined) by the 2004 terrestrial survey:

- *Ferula persica* (AzRDB) - a herbaceous perennial plant of the Family Apiaceae which grows in arid climates, typically occurring on lower habitats;
- *Cladochaeta candidissima* (IUCN, Indeterminate) – which occurs within coastal sands, rubbly places, dry stream beds and in plains;
- *Glycyrrhiza glabra* (AzRDB) - (European licorice) shrub/semi-shrub in arid habitats;
- *Nitraria schoberii* (AzRDB) – a wood shrub perennial; and
- *Ammochloa palaestina* (AzRDB) – which is found at sandy, arid habitats.

The following two species have been recorded in the vicinity of the SD2 Infrastructure area:

- *Astragalus bakuensis* (AzRDB) - Shrub/semi-shrub coastal (recorded in the 2001 Baseline Report survey report and 2006 Pipeline Landfall Monitoring Report; and
- *Iris acutiloba* (AzRDB) - Arid, sandy habitats recorded in the 2001 Baseline report survey and the 2005, 2008 and 2009 flora surveys. The 2009 survey recorded this species at monitoring location SS1-2 which lies to the north east of the Terminal.

None of the above species were recorded during a botanical survey undertaken within the SD2 Infrastructure area carried out in 2008 and it is considered highly unlikely that colonisation of these species would have occurred within this area since this date.

#### Sensitivity

Whilst the results of previous surveys have indicated the presence of floral species included in the AzRDB or IUCN lists within the regional area, the latest 2008 data indicates that none of these species are located within the SD2 Infrastructure area. Local vegetation is therefore characterised by floral species which are typical for the area and are neither rare nor threatened.

#### 6.4.7.3 Fauna

Terrestrial and wetland faunal surveys in the Terminal vicinity have been undertaken between 2001 and 2010.

During the 2002 wetland survey, four species of reptile were recorded: *Bufo viridis*; *Hyla arborea*; *Rana ridibunda* and *Mauremys/Emys orbicularis*. None of these species are included in the AzRDB, however two species (*Emys orbicularis* and *Hyla arborea*) are classified as Lower Risk/Near Threatened by IUCN. A number of reptiles were also recorded during the 2002 wetland survey.

The 2005 fauna survey identified the presence of:

- *Phrynocephalus helioscopus* - lizard (not included in AzRBD); and
- *Testudo graeca* - spur-thighed tortoise (included in the AzRDB).

The survey also identified the presence of Euphrates jerboa (*Allactaga euphratica*) and grey hamster (*Cricetulus migratorius*) which are IUCN Lower Risk/Near Threatened; and the marbled polecat (*Vormela peregusna*) which is included in the AzRDBand Conservation Dependent according to IUCN. In addition, wolf (*Canis lupus*) was recorded which does not have a designated conservation status in Azerbaijan.

### Sensitivity

While faunal surveys have been completed, it is not possible to identify trends over time in relation to the total numbers of geographical distribution, due to the highly variable identification within previous surveys. With regard to the spur thighed tortoise (which is a AzRDB listed species) seasonal sensitivity (breeding and incubation) is presented within Table 6.11.

**Table 6.11 Breeding and Incubation Periods of the Spur-Thighed Tortoise**

Common Name	Event	Month											
		J	F	M	A	M	J	J	A	S	O	N	D
Spur-thighed tortoise	Breeding												
	Incubation												

#### 6.4.7.4 Breeding Birds

Breeding bird surveys have been undertaken in the Terminal vicinity since 2001 with the most recent surveys completed in 2008, 2009 and 2010. The sampling locations used during the later surveys, which used a fixed-point sampling grid and point sampling techniques, are shown in Figure 6.10.

**Figure 6.10 Bird Monitoring Locations Around the Terminal (2008, 2009 and 2010)**

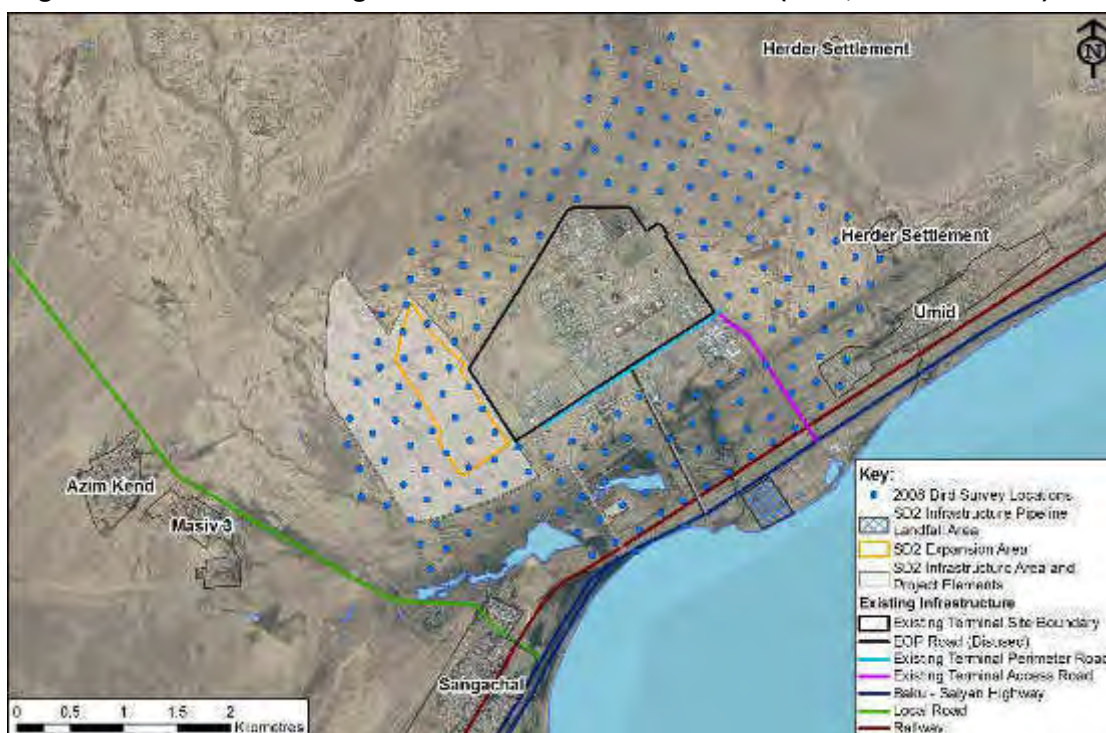

Over the 2008, 2009 and 2010 surveys, 132 species of birds were identified, of which 86 species occurred in 2010. Of these, 23 were resident species (i.e. species that normally remain within the Sangachal area throughout the year). The remaining 63 species were migratory species. This pattern of a larger number of migratory species, and a limited resident breeding fauna, is reflected in the earlier survey results from 2005 onwards.

The most widespread species occurring during the surveys (recorded at more than 25 recording locations) included *Apus apus* (Common Swift), *Coturnix coturnix* (Common Quail), *Delchion urbica* (House Martin), *Hirundo rustica* (Barn Swallow), and *Oeanthe isabellina* (Isabelline Wheatear). All of these are common breeding birds and are not included in the AzRDB or classified by IUCN.

In 2008 the bird survey results specific to the SD2 Infrastructure area (as defined within Figure 6.10 above) were analysed. It was reported that, in 2008, a total of 47 species of birds during 6 survey cycles were recorded. However, for individual monitoring cycles the total number of species observed was considerably less than 47 and species composition changed with time. Although 47 species were observed in the area, the greatest number of bird species observed at any single site during the year was 19, south of the SD2 Infrastructure area where denser vegetation cover occurs.

The surveys found that bird species diversity and numbers progressively reduced from the SD2 Infrastructure area towards the north, averaging approximately 4.25 per monitoring site.

During the 2009 and 2010 bird surveys, the following species which are of conservation significance were recorded in the Terminal vicinity:

- 2009 bird survey:
  - Mute Swab (*Cygnus olor*) which is included in the AzRDB; and
  - Pygmy Cormorant (*Phalacrocorvax pygmaeus*) which is IUCN Least Threatened.
- 2010 bird survey:
  - Pallid Harrier (*Circus macrourus*) which is IUCN Near Threatened and included in the AzRDB;
  - European Roller (*Coracias garrulous*) which is IUCN Near Threatened;
  - Red-footed Falcon (*Falco vespertinus*) which is IUCN Near Threatened; and
  - Black-bellied Sandgrouse (*Pterocles orientalis*) which is included in the AzRDB.

## Sensitivity

Surveys to date have shown that there has been little change in bird species richness and numbers over time, and concluded that results have been affected to a greater extent by the distribution of suitable habitat in the general area than by operations at the Terminal. Key sensitivity for breeding birds is during the breeding season which typically starts in mid-March and continues until the end of August.

## 6.5 Coastal Environment

### 6.5.1 Setting

The coastal zone, between the Baku-Salyan Highway and the Caspian Sea shoreline, comprises a platform of layers of limestone and marine sediments. The landward slope has been quarried away for sand/aggregate. To the seaward there is a limestone platform sloping down to the water's edge, with small areas of exposed finer material.

### 6.5.2 Coastal Habitat

The area previously quarried, as discussed in Section 6.5.1, within the coastal zone supports desert vegetation similar to that of disturbed habitat around the SD2 Infrastructure area and is dominated by sparse *Salsola nodulosa*. The platform to the seaward also supports *Salsola*, with other species, including Suaeda, Artemesia and Armeria species. The area where the previous ACG/SD pipelines were installed has been rehabilitated using live plants. The results of surveys undertaken in 2007 and 2010 indicate that this effort has been successful with up to 57% vegetation cover by perennial species identified in 2010.

## Sensitivity

Surveys completed to date show that following rehabilitation, the disturbed coastal habitat is recovering following the pipeline works completed between 2001 and 2006. There are no rare or threatened species present and bird habitat is typical of the area within the Terminal vicinity.

### 6.5.3 Coastal Birds

At a regional level, the coastal zone of the Caspian Sea has been identified as an area of ornithological importance as it supports both internationally and nationally significant numbers of migrating and overwintering birds. Important ornithological sites, located on the Caspian Sea's southwest coast, include (refer to Figure 6.11):

- **Kura Delta** – which supports large populations of waders during the spring migration (approximately 92km south of the Terminal);
- **Kyzyl-Agach State Nature Reserve** – established in 1929 for the protection of wintering and migratory waterfowl, waders and steppe birds. It is estimated that there are 248 bird species within the reserve, a number of which are protected species (approximately 105km south of Baku);
- **Pirsaget Islands** – which supports important bird colonies (approximately 37km south of the Terminal);
- **Shahdili spit and Pirlahi Island**<sup>23</sup> – the Shahdili spit is designated as a sanctuary, and together with Pirlahi Island has been identified as a candidate Ramsar site (approximately 77km and 98km respectively north east of Terminal); and
- **Bandar Kaisher Lagoon and mouth of Sefid Rud** – this area is an important staging and wintering area for a wide variety of migratory wildfowl (approximately 317km south of Terminal).

Details of species and numbers found in these locations are provided within the COP ESIA<sup>24</sup>.

---

<sup>23</sup> Now declared the Absheron National Park.

<sup>24</sup> COP ESIA (2010).

**Figure 6.11 Important Ornithological Sites Located on the Southwest Caspian Coast**



A desktop study was undertaken in January 2010 which reviewed the number and species of birds observed in surveys between 2002 and 2006 along the coastlines of the Shabdilli spit, Pirillahi Island, and within the ACG Contract Area<sup>25</sup>. The review highlighted that the breeding season of birds on the Shabdilli and Pirillahi coastline commences at the end of April and early May and continues until mid-July. At the end of July and beginning of August, birds leave their nesting places and disperse. During the breeding season, 18 species were recorded along the Pirillahi coastline and 16 species along the Shabdilli coastline.

The Shabdilli and Pirillahi coastlines are located within a major migratory route for migrating waterfowl and coastal birds, who nest in the European parts of Russia, western Siberia, and north-western Kazakhstan and migrate to the southern coast of the Caspian Sea, the Kur-Araz lowland, Turkmenistan, southwest Asia and Africa for the winter. The migration routes are indicated in Figure 6.12. The autumn migration commences in the second half of August and continues until mid-December, with the most active period during November, while the spring migration starts in the second half of February and ends in April, with the most active period during March.

<sup>25</sup> COP ESIA, 2010



**Figure 6.12 Bird Migration Routes**

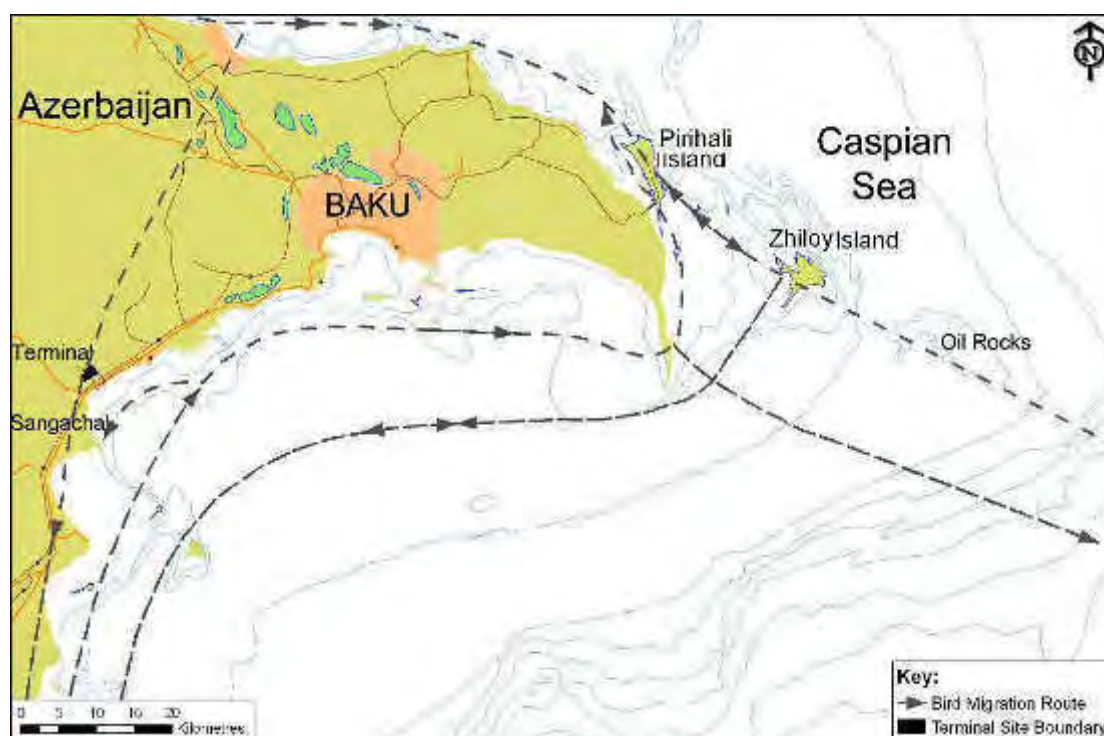

**Sensitivity**

There are no important ornithological sites located on the southwest Caspian coast that are located within close proximity to the SD2 Infrastructure area.

**6.6 Archaeology and Cultural Heritage**

A non-intrusive archaeology and cultural heritage field survey was undertaken in 2001 for the Shah Deniz Stage 1 (SD1) Project<sup>26</sup> and covered an area within a 2.5km radius of the Terminal. Key finds within the survey area are detailed within Table 6.12 and shown on Figure 6.13. A second survey in 2002 conducted by a team of UK archaeologists confirmed the presence of several archaeological sites (ID2-4 within Figure 6.13) in the area north of the current Terminal.<sup>27</sup>

**Table 6.12 Summary of 2001 Archaeological Survey Finds/Cultural Heritage Sites**

ID	Find/Site	Comment
1	Caravanserai	Medieval inn. Protected state monument.
2	1 <sup>st</sup> and 2 <sup>nd</sup> Sangachal Settlements	Medieval and Antique structural remains and extensive habitation area. Reportedly dating back to 2 <sup>nd</sup> century BC. Rock art found within one rockshelter.
3	3 <sup>rd</sup> Sangachal Settlement	Structural remains noted in 3 <sup>rd</sup> Sangachal Settlement. Glazed and unglazed pottery shards indicating potential medieval settlement of between 2-20 hectares.
4	4 <sup>th</sup> Sangachal Settlement	
5	5 <sup>th</sup> and 8 <sup>th</sup> Sangachal Settlements	This medieval settlement may cover several hectares. Structural remains were recorded in 8 <sup>th</sup> Sangachal.
6	6 <sup>th</sup> Sangachal Settlement	This possible medieval settlement includes the remains of several structures a variety of domestic ceramics.
7	9 <sup>th</sup> Sangachal	Glazed and unglazed pottery shards indicating potential medieval settlements of between 2-20 hectares.
8	Sangachal Gochdash Memorial	
9,10 & 11	Sangachal cemetery and Sophi-Hamid Sepulcher	Approximately 20 hectares. Reported to contain burials from 13 <sup>th</sup> century towards the north of the cemetery footprint.
n/a	Sand Cave	Cave with man-made interior walls. Protected state monument.

<sup>26</sup> SD1 ESIA, 2002

<sup>27</sup> Desmond et al. 2002

**Figure 6.13 Archaeological Survey Finds/Cultural Heritage Sites, 2001**



These surveys identified several monuments or archaeological sites in the vicinity of the Terminal that date from the Medieval period; several of the archaeological sites also date from the Antique period. One of these (ID7 within Figure 6.13) is located in the SD2 Infrastructure area. This archaeological site is referred to as 9<sup>th</sup> Sangachal<sup>21</sup>.

A walkover reconnaissance survey of the SD2 Infrastructure area was conducted in 2011. The locations within the following areas were surveyed:

- SD2 Infrastructure area;
- Areas west of the SD2 Infrastructure area;
- The Pipeline Landfall Area; and
- The vicinity of the Caravanserai.

The SD2 Infrastructure area is located on a broad alluvial fan at the foot of Mt. Qaraqush (refer to Section 6.4.1). The landform terminates at the Caspian littoral. Remnant platforms of limestone are located near the shoreline at the SD2 Pipeline Landfall Area and adjacent to the Caravanserai. Vegetation in the Terminal vicinity is very sparse (refer to Section 6.4.7.1), affording close to 100% surface visibility. As stated in Section 6.4.2, a wadi passes to the west of the SD2 Infrastructure area. An examination of the banks of the wadi to the south and west of the Terminal indicated that the alluvium measures a minimum of 4m in thickness.

The SD2 Expansion Area has undergone significant disturbance and has resulted in the creation of two significant spoil heaps in the area (refer to Section 6.4.7.1). A variety of linear disturbances, including earthen berms, pipeline, fences and roads were observed to the south and west of the Terminal.

The sub-surface impacts of the linear disturbances appear to be relatively limited and unlikely to have been sufficient to damage any potential archaeological features which may remain intact under them. While it was not possible to characterise the degree of sub-surface impact below the spoil heaps, it can be expected that earth moving activities that created these spoil heaps will have significantly impacted any archaeological features that may have been located in these areas.



Approximately 60-80% of the SD2 Pipeline Landfall Area has been thoroughly disturbed by quarrying. An approximate 80-100m wide remnant of a limestone platform remains intact, sloping up from the Caspian shoreline in a series of limestone ledges. There is a thin veneer of soil remaining at the crest of this landform. Any archaeological sites in this area would be found on the surface. The broad expanses of exposed limestone also have the potential to contain rock carvings. During the reconnaissance survey no archaeological sites or rock carvings were observed. A cave, referred to by the Ministry of Culture and Tourism (MoCT) as Sand Cave, is located approximately 100m west of the Pipeline Landfall Area. The MoCT has informed BP that this is a protected State monument.<sup>28</sup>

Figure 6.14 illustrates the SD2 Pipeline Landfall Area and where there is the potential for archaeological resources and rock carvings to remain. Within the area quarried there is no potential for archaeological remains.

**Figure 6.14 The SD2 Pipeline Landfall Area and the Area Undisturbed Through Quarrying**

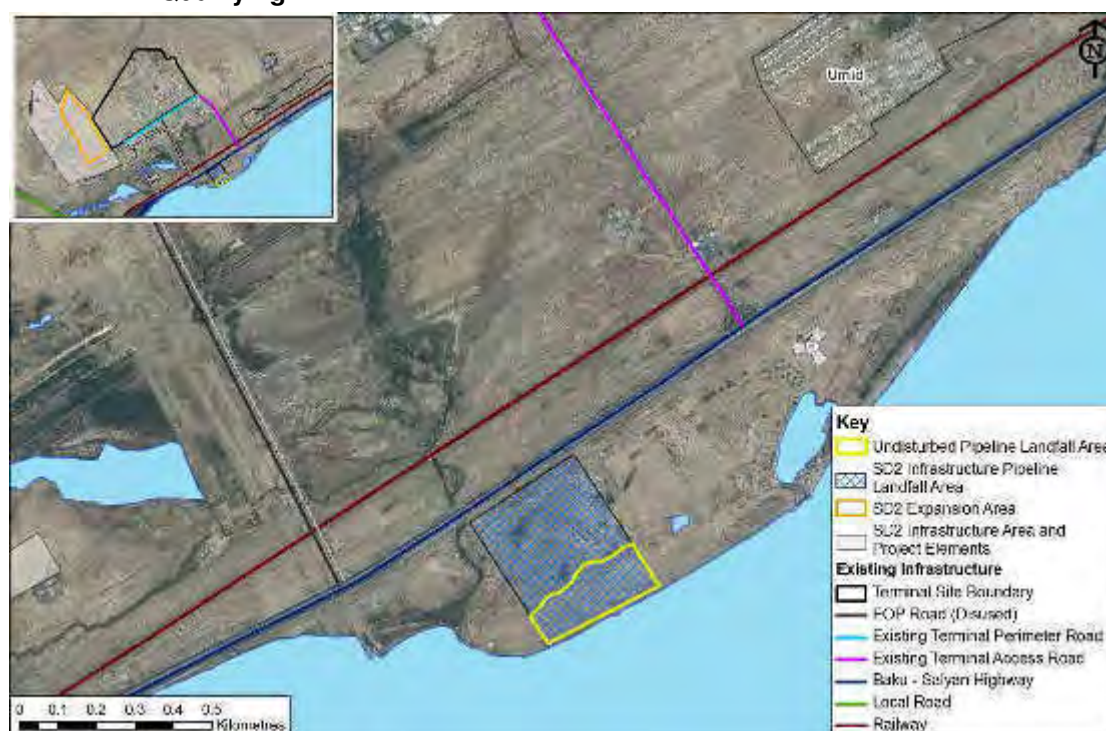

The 2011 reconnaissance survey included a closer examination of the Caravanserai monument (Figure 6.13). The building is of block masonry construction with a two-storey façade and two wings that surround a central courtyard (Figure 6.15). The building is part of a larger compound that includes several other utilitarian structures and a fenced garden. Two of the associated structures appear to serve as wells or springhouses; they lie on a terrace margin adjacent to the wetland. Steps lead down into the waters of the wetland. The presence of these structures and their orientation to the wetland suggests that the wetland feature may pre-date the construction of the adjacent railway line. The entire complex measures approximately 0.54ha. The Caravanserai building appears to be structurally sound. It does not appear to currently be in use; herders were using it for rest and shade at the time of the reconnaissance survey. Domestic artefacts, kitchen glass and pottery shards, were noted in the area around the building. A notable array of graffiti in a number of different scripts was recorded carved into the limestone blocks near the building's entrance.

<sup>28</sup> Personal communication, meeting between BP and MoCT on 2<sup>nd</sup> June 2011

**Figure 6.15 Courtyard Interior of the Caravanserai**



### **Sensitivity**

The 2001 survey for SD1 Project indicated that 9<sup>th</sup> Sangachal may represent a settlement extending over several hectares. Each of the archaeological sites identified during the survey was categorised as of high importance. The 9<sup>th</sup> Sangachal is described as of republic importance.

No archaeological remains were noted during the 2011 reconnaissance survey. The likelihood of encountering extensive settlement remains in this area appears to be relatively low, because of the lack of permanent water sources. Although the previously known site within the SD2 Infrastructure area (9<sup>th</sup> Sangachal) identified in the 2001 survey was not relocated during the reconnaissance survey, a further detailed survey will be undertaken to confirm its presence as well as the potential presence of small archaeological sites<sup>29</sup>.

<sup>29</sup> Note that an archaeological walkover survey of the SD2 Infrastructure area was undertaken in 4Q 2011 by URS and the Azerbaijan Institute of Archaeology and Ethnography (IoAE). The results of the survey are pending however, it is understood that no significant archaeological finds were encountered.

## 7. Socio-Economic Description

### Contents

7.1	Introduction.....	2
7.2	Geographic Context .....	2
7.3	Data Sources.....	3
7.4	Socio-economic Conditions.....	4
	7.4.1 Population and Demographics .....	4
	7.4.2 Land Use and Ownership.....	6
	7.4.3 Infrastructure .....	7
	7.4.4 Education and Training .....	10
	7.4.5 Health.....	11
	7.4.6 Employment and Livelihoods .....	12
	7.4.7 Economic Activity .....	15
	7.4.8 Income and Expenditure .....	15
7.5	Community Investment.....	17
7.6	Local Content Development.....	18

### List of Figures

Figure 7.1	Garadagh District, the Terminal and Surrounding Communities .....	3
Figure 7.2	Land Use within Vicinity of the Terminal.....	7
Figure 7.3	BP Projects Construction Workforce, 2002 to 2007 .....	14

### List of Tables

Table 7.1	Relevant Data Sources .....	4
Table 7.2	Azerbaijan Population 1990 to 2010.....	4
Table 7.3	Number of IDPs Within the Garadagh District .....	5
Table 7.4	National Age Profile, Urban and Rural, 2010.....	5
Table 7.5	District Population, In-Migration , Death and Fertility Rates, 2005-2010.....	6
Table 7.6	Bus Routes Serving the Communities within the Terminal Vicinity.....	8
Table 7.7	Perceived Conditions of Public Transport in the Communities within the Terminal Vicinity.....	8
Table 7.8	Source of Potable Water in the Communities within the Terminal Vicinity .....	9
Table 7.9	Perceived Reliability of the Water Network in the Communities within the Terminal Vicinity.....	9
Table 7.10	Perceived Quality of the Potable Water Supply in the Communities within the Terminal Vicinity.....	9
Table 7.11	Perceived Condition of Drains and Sewage Infrastructure in the Communities Within the Terminal Vicinity.....	10
Table 7.12	Level of Satisfaction with Existing Waste Disposal Arrangements in the Communities Within the Terminal Vicinity.....	10
Table 7.13	Type of Healthcare Infrastructure Used by Households in the Communities within the Terminal Vicinity.....	11
Table 7.14	Most Reported Health Problems in Communities Surrounding the Terminal During Four Week Period (May – June 2011) .....	12
Table 7.15	Employment Locations for Households Surveyed in in the Communities within the Terminal Vicinity.....	13
Table 7.16	Monthly Incomes in the Communities within the Terminal Vicinity .....	16
Table 7.17	Primary Sources of Income in the Communities within the Terminal Vicinity.....	16
Table 7.18	Secondary Sources of Income in the Communities within the Terminal Vicinity ..	16
Table 7.19	Monthly Household Expenditure in the Communities within the Terminal Vicinity	17
Table 7.20	Source of Food Purchases in the Communities within the Terminal Vicinity.....	17
Table 7.21	BP/AIOC Social Spend 2002 to 2009 .....	18
Table 7.22	Local Content Spend 2006 to 2010 .....	18

## 7.1 Introduction

This Chapter describes the socio-economic baseline conditions relevant to the SD2 Infrastructure Project. The scope of the chapter has been informed through the scoping process described in Chapter 8, where the following socio-economic interactions were identified as a result of SD2 Infrastructure Project activities:

- Disruption or restriction of access to natural resources;
- Employment creation and de-manning;
- Training and skills development;
- Procurement of goods and services;
- Offsite construction vehicle movements; and
- Road and rail works.

The key socio-economic receptors that may be impacted by the Project and are described in this Chapter include:

- Local and regional communities;
- Herders, recreational and commercial fishermen and recreational users of the shoreline;
- Users of road and rail infrastructure; and
- Local, regional and national businesses.

The following socio-economic information is presented in this Chapter to allow assessment of socio economic impacts associated with the SD2 Infrastructure Project:

- Population and Demographics;
- Land Use and Ownership;
- Infrastructure;
- Education and Training;
- Health;
- Employment and Livelihoods;
- Income and Expenditure;
- Amenity and Living Conditions; and
- BP Community Investment Programmes.

Where relevant, information is presented at the following geographical levels:

- **National** - relevant to the Republic of Azerbaijan;
- **District** - relevant to the Garadagh District; and
- **Local** - relevant to the local communities in the Terminal vicinity; Sangachal Town, Umid, Azim Kend and Masiv 3.

This Chapter has been prepared using the initial findings of the Stakeholder and Socio-Economic Survey (SSES) which are due to be reported in full by 3Q 2011<sup>1</sup>.

## 7.2 Geographic Context

The SD2 Infrastructure Project is located adjacent to the Terminal and lies within the Garadagh District, which includes Baku and then extends south along the Caspian coast to the south of Alyat. The Garadagh District was established in 1923 and comprises five city settlements including Lokbatan which is the administrative centre. The extent of the Garadagh District and the location of the local communities in relation to the Terminal are shown in Figure 7.1.

---

<sup>1</sup> Refer to Chapter 8 for further details regarding the scope of the SSES.



**Figure 7.1 Garadagh District, the Terminal and Surrounding Communities**



The Garadagh District Executive Power (the Executive Power) is the authority responsible for administration<sup>2</sup> within the region. The key responsibilities of the Executive Power include safeguarding the rights and freedom of its citizens, safeguarding statutory and other interests, and providing support to the population in terms of economic, social and cultural development.

The Executive Power manages the Garadagh District's education, culture, public health, sport institutions and the budgets of 11 municipalities whose members are elected by residents living in the communities. Sangachal Town and Umid are both municipalities and responsible for their own provision of housing, roads, electricity, water, sanitation, waste collection, heating infrastructure and gas supply. The communities of Masiv 3 and Azim Kend fall under the municipality of Sangachal.

### 7.3 Data Sources

Socio-economic data presented in this Chapter has been taken from the following primary and secondary sources of data:

- **Primary data** - collected during the SSES; and
- **Secondary data** - collected from recognised institutions including the United Nations, International Monetary Fund, Statistical Committee of the Republic of Azerbaijan and the Garadagh Executive Power.

A list of the primary and secondary data sources is provided in Table 7.1.

<sup>2</sup> ERM (2009) Garadagh Cement Project New Dry Kiln 6: ESIA

**Table 7.1 Relevant Data Sources**

Date	Title of Document/Survey
2006	ACQUIRE, Reproductive Health & Services in Azerbaijan 2005: Results of a Baseline Survey in Five Districts, E&R Study #6
2006	USAID, Country Profile
2007	UNDP, Gender Attitudes in Azerbaijan: Trends and Challenges, Azerbaijan Human Development Report
2007	USAID, Country Health Statistical Report Azerbaijan
2008	International Monetary Fund, Republic of Azerbaijan: Statistical Appendix 2007
2008	State Statistical Committee of the Republic of Azerbaijan, Demographic & Health Survey 2006
2009	Garadagh Cement Project New Dry Kiln 6 ESIA 2009
2009	Gizildash (Qizildas) Cement Factory ESIA, NORM, 2009
2010	United Nations Azerbaijan, United Nations Development Assistance Framework 2011-2015
2010	AIOC Chirag Oil Project ESIA, 2010
2010	International Crisis Group (ICG) Global 2010 Report
2010	State Statistical Committee of the Republic of Azerbaijan, Socio-economic Development of the Settlements of Baku City
2010	ICG, Azerbaijan: Vulnerable Stability Europe Report No.27
2010	Agents of Change: Reflections on a working partnership between BP Azerbaijan and the International Institute for Environment and Development (IIED)
2011	Data provided to BP from Garadagh District Executive Power
2011	SD2 Project Stakeholder and Socio-Economic Survey (SSES) – Preliminary Findings <sup>3</sup>

## 7.4 Socio-Economic Conditions

### 7.4.1 Population and Demographics

#### Population

Population data for Azerbaijan from 1990 to 2010 is provided in Table 7.2.

**Table 7.2 Azerbaijan Population 1990 to 2010<sup>4</sup>**

	1990	1995	2000	2005	2009	2010
Azerbaijan Republic ('000)	7,131.9	7,643.5	8,032.8	8,447.3	8,896.9	8,997.4
Male (%)	48.8	49.1	48.8	48.9	49.0	49.1
Female (%)	51.2	50.9	51.2	51.1	51.0	50.9
Urban population ('000)	3,847.3	4,005.6	4,116.4	4,477.6	4,818.3	4,866.6
Rural population ('000)	3,284.6	3,637.9	3,916.4	3,969.7	4,078.6	4,130.8

The data indicates that in 2010, the population of Azerbaijan was 8,997,400 with a gender distribution of 49% male and 51% female. The urban population in both 1990 and 2010 was 54% indicating that the proportion of urban citizens (as compared to rural citizens) has remained constant over the past 10 years.

Of those living in urban areas, 42% live in Baku. There are indications, however, that the actual population of Baku may be significantly higher than official figures suggest. Many people who move to Baku for employment on a temporary or permanent basis, may retain their registration in their place of origin. The United Nations Development Programme (UNDP) has suggested that the greater Baku metropolitan area may be home to approximately three million people, or 35% of the national population<sup>5</sup>.

In the early 1990s, Internally Displaced Persons (IDPs) were displaced as a result of the occupation caused by conflict with Armenia in and around Nagorno Karakakh region of the Republic of Azerbaijan. Many of these people were forced to relocate and it is estimated that

<sup>3</sup> Refer to Chapter 8 for further details regarding the scope of the SSES and current status

<sup>4</sup> State Statistical Committee of the Republic of Azerbaijan (2010) Demographic Indicators

<sup>5</sup> United Nations Development Programme (UNDP) Azerbaijan, 2007: Converting Black Gold into Human Gold: Using oil Revenues to Achieve Sustainable Development.

there are currently 10,521 IDPs living in Garadagh District (Table 7.3 below)<sup>6</sup> which have increased from 2006 to 2010. In addition, there were approximately 2,400 refugees in 2006. The number of IDPs in Garadagh currently accounts for 10% of the District population.

**Table 7.3 Number of IDPs Within the Garadagh District**

	2006	2007	2008	2009	2010
<b>Number of IDPs</b>	10,271	10,290	10,357	10,487	10,521

At the local level, Umid and Sangachal Town have significant populations of IDPs. Umid was originally established in 1999 to house 250 IDPs from the Nagorno Karakakh conflict and today, Umid has around 2,000 inhabitants, of which 75% are IDPs. In Sangachal Town in 2001, 645 out of 4,500 (14%) inhabitants were IDPs.

In Azerbaijan, the population in urban areas is generally older (refer to Table 7.4<sup>7</sup>), both in percentage and absolute terms, than in rural areas. There is a larger proportion of people in the age range 45-69 years in urban areas. Overall, however, the dependency ratio (the proportion of the population which is not economically active) is higher in rural areas (33%) than in urban areas (29%).

**Table 7.4 National Age Profile, Urban and Rural, 2010**

Age	Total		Urban		Rural	
	('000)	%	('000)	%	('000)	%
<b>0-4:</b>	748.6	8%	369.7	4%	378.9	4%
<b>5-9:</b>	582.3	7%	283.3	3%	299.0	3%
<b>10-14:</b>	657.0	7%	311.7	4%	345.3	4%
<b>15-19:</b>	911.0	10%	470.6	5%	440.4	5%
<b>20-24:</b>	928.8	10%	506.7	6%	422.1	5%
<b>25-29:</b>	795.2	9%	442.0	5%	353.2	4%
<b>30-34:</b>	666.4	7%	366.0	4%	300.4	3%
<b>35-39:</b>	624.7	7%	329.9	4%	294.8	3%
<b>40-44:</b>	671.1	8%	360.5	4%	310.6	4%
<b>45-49:</b>	700.7	8%	405.3	5%	295.4	3%
<b>50-54:</b>	559.9	6.2%	338.8	3.8%	221.1	2.5%
<b>55-59:</b>	355.0	4%	226.5	2.5%	128.5	1.4%
<b>60-69:</b>	360.8	4%	227.1	2.5%	133.7	1.5%
<b>70 and over:</b>	435.9	5%	228.5	2.5%	207.4	2.3%
<b>Total:</b>	8,997.4	100%	4,866.6	54%	4,130.8	46%

Between 2004 and 2009 birth rates and the natural fertility rate increased in parallel with a decline in maternal and infant mortality rates. By 2009, average life expectancy was 73.5 years<sup>7</sup> (70.9 years for men and 76.1 years for women). This represents a significant positive change since 1990 when average life expectancy was 71.1 years (67.0 for men and 74.8 years for women).

Key population indicators for the Garadagh District are presented in Table 7.5 for the period 2005 to 2010<sup>8</sup>.

<sup>6</sup> ERM (2009) Garadagh Cement Project New Dry Kiln 6: ESIA

<sup>7</sup> State Statistical Committee of the Republic of Azerbaijan (2010) Demographic Indicators

<sup>8</sup> Garadagh Executive Power (2011).



**Table 7.5 District Population, In-Migration , Death and Fertility Rates, 2005-2010**

	2005	2006	2007	2008	2009	2010
Population	101,100	102,600	104,191	105,997	107,819	111,035
In-migration	82	59	34	116	50	85
Number of Deaths	534	559	554	790	518	468
Number of Births	1,706	2,125	1,259	3,261	2,097	2,126

Note: Data regarding out-migration is not available

The data indicates that the population of the Garadagh District increased by 10% between 2005 and 2010. This appears to be due to a moderate increase in in-migration (4%), an increase in the number of births (25% higher in 2010 than in 2005) and a significant decline in the number of deaths (12% lower by the end of the period). Some caution should be used in interpreting these figures: there is, for example, an unexplained spike in in-migration, deaths and births in 2008. No data was available regarding out-migration. Population data for Sangachal Town, Umid, Azim Kend and Masiv 3 is currently unavailable.

### Ethnicity

The majority of the national population (91% in 1999) are ethnically 'Azeri', with the remaining 9% made up of a range of ethnic groups including Lezghin, Tatar, Russian and Ukranian<sup>9</sup>.

### 7.4.2 Land Use and Ownership

Land use within the vicinity of the Terminal is dominated by the four local communities, the Baku-Salyan Highway, the railway, and the presence of industrial facilities (refer to Figure 7.2). There are, in addition, two herder settlements located to the north east of the Terminal. Open land is characterised by areas for animal herding (primarily cattle, goats and sheep) and by local, generally unsealed, access roads. A distinct wetland area is present near the highway and railway line.

Land to be acquired for the SD2 Infrastructure Project is understood to be 100% state owned and it is understood that there are no buildings or similar features present within the areas where acquisition is planned.

Due to poor soils and arid climate, there is no arable agriculture in the area although it is understood that land in the vicinity of the Terminal is used by herders. Households within the local communities are understood to use small garden areas situated immediately adjacent to their housing blocks, mainly for subsistence agriculture. Data from the SSES indicates that 35% of the households surveyed have land for agricultural production, which includes feedstock for animals and areas to house poultry.

Along the shoreline area between Sangachal Town and Umid, recreational and commercial fishing activities occur, along with some recreation use (e.g. walking).

Between the coastline and highway to the east of the Pipeline Landfall Area, a small number of buildings are under construction. It is understood that these comprise approximately seven holiday homes. The majority of the construction sites comprise one, or more, buildings that are partially complete and some are without roofs or finished walls. During a walkover survey in June 2011, it was observed that one of the buildings is currently inhabited by a single family although their legal right to reside in this building is unclear.

<sup>9</sup> ERM (2009) Garadagh Cement Project New Dry Kiln 6: ESIA

**Figure 7.2 Land Use within the Vicinity of Terminal**

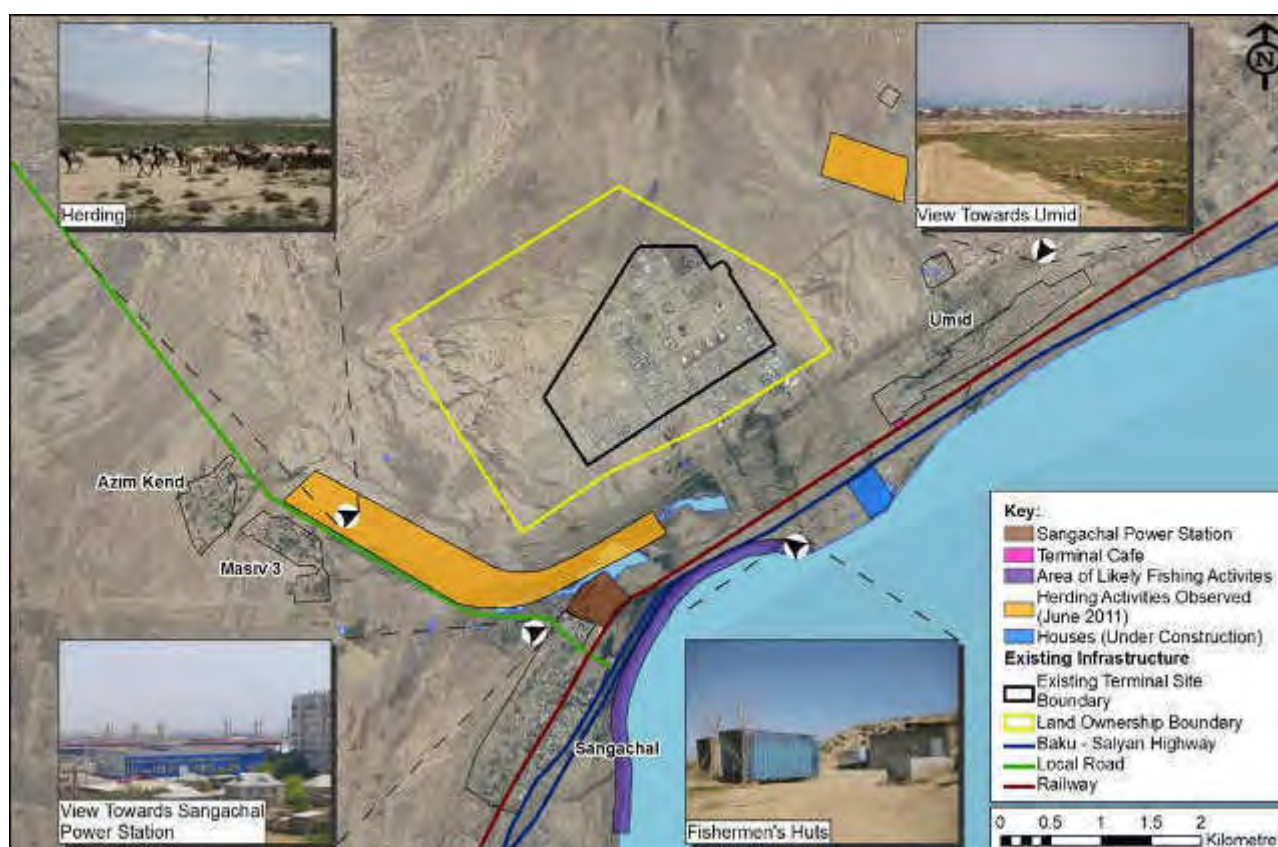

### 7.4.3 Infrastructure

#### Road Transport

Azerbaijan's public road network was primarily developed during the Soviet era and in many areas roads are now in a poor condition. However, the Baku-Salyan Highway is well-maintained and provides a rapid link from Baku to Astara. Existing traffic flow levels along the highway are estimated to be between 10,000 to 20,000 vehicles per day<sup>10</sup>.

The internal roads within the local communities are in poor condition and, following heavy rain, the roads can become impassable until soil has dried out. Data gathered by the SSES indicates that the majority of residents interviewed in Azim Kend and Masiv 3 (88% and 64%, respectively) consider the condition of local access roads as 'poor'. Roads connecting the communities of Sangachal Town and Umid were perceived more favourably by local residents; 75% and 62% respectively considered roads conditions to be 'good'.

#### Public Transport

There are several bus routes that provide public transport to the local communities, as summarised in Table 7.6. With the exception of Sangachal Town, there are no direct bus services to Baku.

<sup>10</sup> Per comms, Head of the Technical Division, Azerbaijan Highway Authority, 2010

**Table 7.6 Bus Routes Serving the Communities within the Terminal Vicinity**

Communities	Bus Number	Route	Frequency	
			AM	PM
Sangachal Town	195	Alyat - Baku	Every 15 minutes	
Sangachal Town	46	Jeyildagh - Lokbatan	9.00am	4.00pm
Masiv 3			8.50am	4.10pm
Azim Kend			8.40am	4.20pm
Umid	164	Sadarak mall - Sahil - Umid	Every 30 minutes	

The railway runs parallel to the Highway and connects Baku with Astara and Tbilisi. The Baku to Hajikabul passenger train stops twice a day (9am and 4.30pm) at Sangachal Train Station.

Data gathered by the SSES (refer to Table 7.7) indicates that the condition of existing public transport is perceived to be 'poor' with the exception of Umid which is rated as 'excellent' (62%).

**Table 7.7 Perceived Conditions of Public Transport in the Communities within the Terminal Vicinity**

Rating	Sangachal Town	Umid	Azim Kend	Masiv 3
Excellent	2%	62%	0%	0%
Good	2%	22%	0%	12%
Satisfactory	5%	8%	12%	20%
Poor	89%	6%	88%	68%
Don't know	2%	2%	0%	0%

## Local Utilities

### *Access to Electricity and Gas*

Data collected by the SSES indicates that all households surveyed have access to electricity 24 hours a day. Access to a mains gas supply varies with the following levels reported:

- Sangachal Town (100%);
- Umid (98%);
- Masiv 3 (80%); and
- Azim Kend (8%).

### *Potable Water and Sanitation*

There have been a number of recent initiatives to improve the water supply and sanitation infrastructure within Azerbaijan. A World Bank loan of US \$230 million was approved in June 2007<sup>11</sup> to build on the Greater Baku Water Supply Project and continue the World Bank's long term support to the improvement of Azerbaijan's water and sanitation sector. The Project focuses on the rehabilitation of water supply and sanitation facilities in and around urban centres of the country. The Project also supports key reforms to modernise sector institutions in order to improve their capacity, institutional and operational effectiveness and commercial and financial viability. By Q3 2013, at least 700,000 people from the Baku area, Greater Baku area, Absheron Peninsula and across 20 other regions in Azerbaijan are expected to have improved access to clean, safe and reliable piped water supply and to wastewater collection and disposal services.

At a local level, potable water is piped directly to the local communities. Data collected by the SSES indicates that potable water is predominately available from either inside the home, or from the yard (refer to Table 7.8). However, a significant minority of households in Masiv 3 purchase potable supplies from water vendors.

<sup>11</sup> World Bank loan ID P096213, June 2007

**Table 7.8 Source of Potable Water in the Communities within the Terminal Vicinity**

Source of Potable Water	Sangachal Town	Umid	Azim Kend	Masiv 3
Water available inside the house	76%	52%	0%	12%
Water available from a distribution point in the yard	24%	48%	88%	72%
Water available from elsewhere (neighbour or other location)	0%	0%	8%	4%
Water purchased in containers from vendors	0%	0%	4%	12%

Additional data was collected on the reliability and quality of the water supply, which is presented in Tables 7.9 and 7.10. Again, the data shows a marked disparity across the local communities. Respondents in Sangachal Town, Umid and, to a lesser degree Azim Kend, considered the reliability of their water supply to be at least 'satisfactory', while 68% of respondents in Masiv 3 perceive the reliability of their water supply to be 'poor'.

**Table 7.9 Perceived Reliability of the Water Network in the Communities within the Terminal Vicinity**

Rating	Sangachal Town	Umid	Azim Kend	Masiv 3
Excellent	3%	0%	0%	0%
Good	75%	62%	52%	0%
Satisfactory	12%	30%	16%	28%
Poor	9%	6%	32%	68%
Don't know	1%	0%	0%	4%
Not available	0%	2%	0%	0%

The highest ratings for water quality were reported in Azim Kend (where nearly half of all respondents reported that their water quality was 'good'), Sangachal Town and Umid. Significant minorities in all local communities, however, reported that their water quality was 'poor'.

**Table 7.10 Perceived Quality of the Potable Water Supply in the Communities within the Terminal Vicinity**

Rating	Sangachal Town	Umid	Azim Kend	Masiv 3
Good	26%	22%	48%	4%
Satisfactory	42%	48%	28%	56%
Poor	29%	28%	24%	36%
Don't know	1%	0%	0%	4%
Not available	2%	2%	0%	0%

Problems associated with the need to use pumps to increase water pressure into the household were reported during Community Focus Groups held in Sangachal Town.

In Sangachal Town it is understood that enclosed canals transport sewage to a collection point near to the sea where it is discharged without any treatment. Data collected by the SSES associated with the condition of the drainage and sewage infrastructure is presented in Table 7.11 and the level of satisfaction with waste disposal is provided in Table 7.12.

**Table 7.11 Perceived Condition of Drains and Sewage Infrastructure in the Communities Within the Terminal Vicinity**

Rating	Sangachal Town	Umid	Azim Kend	Masiv 3
Good	59%	76%	0%	0%
Satisfactory	12%	16%	0%	0%
Poor	5%	2%	8%	28%
Don't know	23%	4%	92%	72%
Not available	1%	2%	0%	0%

**Table 7.12 Level of Satisfaction with Existing Waste Disposal Arrangements in the Communities Within the Terminal Vicinity**

Rating	Sangachal Town	Umid	Azim Kend	Masiv 3
Good	49%	52%	0%	0%
Satisfactory	20%	16%	0%	0%
Poor	11%	20%	16%	44%
Don't know	20%	10%	84%	56%
Not available	0%	2%	0%	0%

The data indicates that the condition of drains and sewage infrastructure is perceived as 'good' in Sangachal Town and Umid. The data also indicates that drainage and sewage infrastructure in Azim Kend and Masiv 3 is not an issue of concern, based upon the response that the majority of residents are not aware of the current status of their waste disposal facilities.

#### 7.4.4 Education and Training

The Azerbaijan education law guarantees the right to education for all its citizens irrespective of race, nationality or sex. In 2008, approximately 2.2 million people were students and education providers at various institutions throughout the country. In the age range of 6 to 16 years, school enrolment rates were approximately 84% of the population. In 2008 86% of workers in the national economy had received an education to secondary level or above, and there was almost universal literacy.

The majority of school age children and teenagers in the Garadagh District attend school, or undertake vocational training/education<sup>12</sup>. Within the Garadagh District, approximately 23,500 children and students study at 22 secondary schools and 3,400 children and students study at 5 specialist schools. There are 24 primary schools in the Garadagh District and one boarding school, with 370 pupils.

The schools and kindergartens in the vicinity of the Terminal include:

- Sangachal Town: 1 secondary school (Number 222), 2 kindergartens (Numbers 299 and 20);
- Umid: 1 secondary school (Number 294); and
- Masiv 3 and Azim Kend: 1 secondary school which serves both communities (the Absheron Azim Kend Secondary School).

Data obtained from Executive Power indicate that the gender distribution of secondary school students in the Garadagh District for 2010 is 55% female which is greater than the 2008 national average which was 48%.

There are currently 28 students in Sangachal Town and ten students in Umid who are studying in higher educational institutions in Baku.

<sup>12</sup> Asian Development Bank (2009) Garadagh Cement Project New Dry Kiln 6: ESIA

### 7.4.5 Health

All residents in the Garadagh District have access to free medical services which is provided through the following facilities:

- Seven public hospitals;
- Two GP clinics;
- Two emergency medical stations, operating eleven ambulances; and
- Seven first aid posts<sup>13</sup>.

In 2009 there were a total of 326 doctors and 735 medical staff working in the medical institutions throughout the Garadagh District which equates to 31.1 doctors and 70.1 other medical staff per 10,000 people<sup>14</sup>.

There are no health facilities in Azim Kend or Masiv 3. Health facilities provided in Umid and Sangachal Town comprise:

- Sangachal Town: An outpatient department (Number 23) of Baku City Hospital and an emergency station (Number 20) with 1 ambulance; and
- Umid: A medical station (Number 23) of Baku City Hospital (Number 20) and a new pharmacy (at the time of writing had not opened).

Data collected by the SSES provides information on the types of health care infrastructure used by households (refer to Table 7.13).

**Table 7.13 Type of Healthcare Infrastructure Used by Households in the Communities within the Terminal Vicinity**

Healthcare Type	Sangachal Town	Umid	Azim Kend	Masiv 3
State clinic	71%	64%	76%	56%
Private clinic	8%	12%	4%	0%
State hospital	11%	18%	20%	36%
Private hospital	3%	4%	0%	8%
Emergency station	2%	0%	0%	0%
Call local doctor to house	4%	2%	0%	0%
Get medical care abroad	1%	0%	0%	0%

The data indicates that the majority of households depend on State clinics or hospitals and relatively few use private healthcare facilities.

An indication of local health problems at each of the local communities experienced during the previous four weeks prior to the survey was recorded during the SSES (undertaken in June 2011). The results are presented in Table 7.14.

<sup>13</sup> Garadagh Executive Power (2011).

<sup>14</sup> Asian Development Bank (2009) Garadagh Cement Project New Dry Kiln 6: ESIA



**Table 7.14 Most Reported Health Problems in Communities Surrounding the Terminal during Four Week Period (May – June 2011)**

Most Reported Health Problem	Four Week Total
Respiratory problems	32
Gastrointestinal problems	31
Cardiological (heart) problems / hypertension	26
Nervous system problems	24
Kidney problems	16
Diabetes	10
Female disorders	10
Cough	9
Allergy	7
Eye/ear diseases	6

The data shows the most frequently reported health problems by the local communities during the previous four weeks were respiratory, gastrointestinal, cardiological and nervous system disorders.

#### 7.4.6 Employment and Livelihoods

According to the data provided by the State Statistical Committee for 2009, a total of 4,071,600 people are classified as being employed in Azerbaijan which includes persons who are self-employed, business owners or working in family farms<sup>15</sup>. A larger figure, a total of 4,331,800 people, is reported to be 'economically active', a term which includes both people who are employed and people who are unemployed but available for work.

The registered unemployment rate in Garadagh District in 2007 was 56%<sup>16</sup>. However, this may have increased in recent years as between 2007 and 2009 large numbers of local workers were discharged following completion of construction works at the Terminal and the construction yard used during the ACG and SD projects. In September 2008, there were approximately 400 people officially registered as unemployed in the Garadagh District, about half of whom were receiving social support. The total number of job vacancies in September 2008 was approximately 1,550<sup>16</sup>. According to the Garadagh District, young people with low qualifications and people over the age of 55 years were most likely to be unemployed<sup>17</sup>.

The SSES collected data on the employment status of heads of households in the local communities in the Terminal vicinity. The results indicated that 34% considered themselves to be employed and 66% unemployed. The 66% level of unemployment reported lies above 56% which was recorded in 2007 for the Garadagh District. For employed persons, the location of their employment is provided in Table 7.15.

<sup>15</sup> State Statistical Committee of the Republic of Azerbaijan (2010) Demographic Indicators.

<sup>16</sup> ERM (2009) Garadagh Cement Project New Dry Kiln 6: ESIA.

<sup>17</sup> Garadagh Executive Power (2011).

**Table 7.15 Employment Locations for Households Surveyed in the Communities within the Terminal Vicinity**

Employment Location	Sangachal Town	Umid	Azim Kend	Masiv 3	Total
In this community	19	13	2	5	39
Sahil community of Garadagh District	1	6	1	4	12
In other communities outside of central Baku	2	1	1	2	6
In central Baku	2		1	1	4
Sangachal Town of Garadagh District			1	2	3
In Sangachal Terminal				1	1
Absheron Khojasan community of Absheron region		1			1
Wherever can get a job (casual earnings)	1				1
Guba region			1		1
<b>Total</b>					<b>68</b>

The results indicate that the majority (57%) of people are employed within their community and a further 18% are employed in Sahil; less than 1% were employed in Baku.

In relation to local livelihoods, a visual inspection of the two herder settlements completed in May 2011 indicated the following:

- Herder Settlement 1 (northeast of the Terminal) – characterised by empty buildings, some of which are occupied during the winter grazing period. At the time of the survey, it is understood this family has moved to summer grazing lands to the north. It is understood that this family was historically resettled within the Terminal vicinity during previous works at the Terminal; and
- Herder Settlement 2 (east of the Terminal) – characterised by a number of buildings, some of which are occupied e.g. one building is owned by a family of seven. It is understood this family have been granted legal rights to 5 hectares of land by Baku City Executive Committee.

It is not known whether herding is a primary or secondary source of income for families located at the herder settlements.

A visual inspection of fishing activities completed in June 2011 indicated the following:

- Fishing activities (both commercial and recreational) were observed on the shoreline to the south of the Terminal and Sangachal Town (refer to Figure 7.2);
- It is estimated that approximately 20-30 people are involved in commercial fishing using small vessels fitted with outboard motors. When the boats are not in use they are stored on the beach. It is understood that some commercial fishermen have a contract with two public companies (Caspian Fish and Fish-breeding Plant in Sahil settlement) and that fishing is their primary source of income. Fish are also, on occasion, sold to local people;
- Fishing huts and nets were observed in the area shown in Figure 7.2 however, it is unknown whether they are currently in use and whether or not they are connected with recreational or commercial fishing; and
- It is understood that fishing activities tend to decrease during the winter period when weather conditions are less favourable.

Figure 7.2 indicates where herding activities has been observed along with locations where fishing boats, huts and nets were present during the June 2011 survey along the shoreline.

Additional surveys are planned to further understand how the areas around the Terminal and along the coastline are used by the herders and fishermen.

### Previous BP Projects Employment and Training

Historically BP projects (construction and operations) have had a significant impact on local and regional employment levels<sup>18</sup>. Total construction employment from combined projects peaked at approximately 5,500 workers in mid-2004. Total employment for the ACG Phase 3 project peaked during 2006 with 2,500 jobs (onshore and offshore construction)<sup>19</sup>. Following completion of these previous projects, there has been a significant decrease in employment opportunities available to the local communities. This is confirmed by the SSES where a number of respondents commented on the reduction in employment since 2007. Figure 7.1 illustrates the construction workforce for ACG Phase 1, 2 and 3, Shah Deniz (Terminal only) and BTC (Terminal only) projects.

**Figure 7.3 BP Projects Construction Workforce, 2002 to 2007**

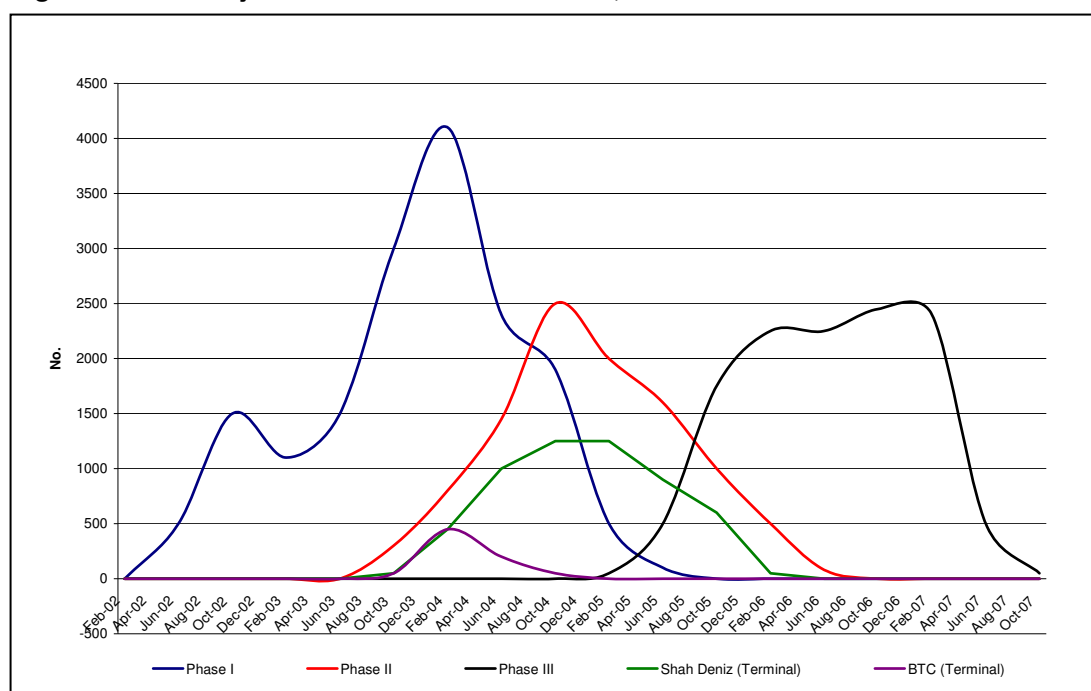

To maximise the positive impact from employment, the ACG Phase 1, 2 and 3, Sangachal Terminal and BTC construction projects adopted the following measures<sup>18</sup>:

- **Targets:** BP were contractually committed to specific national content targets through each of the projects. By September 2003 85% of the construction workforce was Azerbaijani<sup>18</sup>;
- **Preference in Recruitment:** BP recruitment policy gave priority to local residents in the Garadagh District and by September 2003, 53% of the construction workforce was from the Garadagh District;
- **Information Centres:** Local community information centres were established in Sangachal Town, Umid and Sahil to enable local people to register for employment and the Centres developed a database of approximately 18,000 potential employees by September 2003; and
- **Training:** Extensive training programmes were implemented both prior to and during employment of the construction workforce. Training focused on HSE, language and computer skills, driving and certified courses including painting, lifting, scaffolding and welding. In one yard alone over 270,000 training hours of HSE training; over 244,000

<sup>18</sup> BP Azerbaijan Sustainability Reports 2006 - 2007

<sup>19</sup> As reported by the ACG Phase 1-3 construction contractors

hours of craft training; and nearly 28,000 hours training in management, administration and computing skills were provided. Over 1,200 externally recognised qualifications were awarded to the yard's workforce during the period.

It is understood that the majority of the workforce employed and trained in the ACG Phase 1, 2 and 3, Sangachal Terminal and BTC construction projects, are now employed elsewhere in Azerbaijan and abroad. Anecdotal evidence suggests that many have used their skills and experience to gain employment in State-run construction yards, in the Baku construction industry and in the oil and gas sector in Kazakhstan and elsewhere. This represents a significant benefit in terms of increasing technical skills and experience within the Azerbaijan workforce.

#### **7.4.7 Economic Activity**

Azerbaijan has experienced impressive economic growth since 2005 which has been driven by the oil sector. Since 2005, the Garadagh District economy has also expanded. In 2007, the total output of products nationally had increased by 79% in comparison with 2003 and equalled 481.2 Million AZN (US\$ 594,100,100). From 2003 to 2007 the national production of manufactured goods increased by 56%<sup>20</sup>.

Economic activities in the Garadagh District are dominated by the industrial sector, primarily oil and gas. There are around 180 registered companies, firms and co-operatives in the Garadagh District which include 15 foreign and joint venture companies. Areas along the coastline southwest of Baku have experienced a significant increase in the growth of heavy industry and this recent trend is expected to continue<sup>20</sup>.

As a result of progressive economic development and general improvement in living conditions between 2003 and 2007, the number of people settling as new residents in the Garadagh District is approximately twice that of the number of people migrating outwards during the same period<sup>21</sup>.

#### **7.4.8 Income and Expenditure**

There are significant differences between urban and rural incomes in Azerbaijan. At a national level in 2006, employment accounted for 31% of all income in Azerbaijan but 42.4% of income in urban households and only 17.4% in rural households.

Self-employment accounted for 29% of income in urban households and 19% in rural areas. In contrast, agriculture accounted for 36% of rural incomes. Although the importance of rural employment increased substantially during the period 2000 to 2006, access to formal employment opportunities and significantly lower salaries in agriculture, remain significant factors in explaining the differences in income levels between urban and rural areas.

The average monthly household income in the Garadagh District in 2009 was about 400 AZN<sup>22</sup> (approximately 365 EURO). This figure is just above the average monthly income reported by households in the four local communities covered by the SSES, which was 393 AZN (358 EURO). A breakdown of the monthly income (AZN) for each of the local communities is presented in Table 7.16.

<sup>20</sup> ERM (2009) Garadagh Cement Project New Dry Kiln 6: ESIA

<sup>21</sup> Per comms, Head of the Technical Division, Azerbaijan Highway Authority, 2010

<sup>22</sup> Garadagh Executive Power (2011).

**Table 7.16 Monthly Incomes in the Communities within the Terminal Vicinity**

Monthly Income (AZN)	Sangachal Town	Umid	Azim Kend	Masiv 3
Minimum	100	50	120	60
Maximum	1,500	1,500	400	700
Average	439	418	228	297

The data shows that households in Azim Kend and Masiv 3 have, on average, significantly lower monthly incomes than those in Sangachal Town and Umid. The average household income in Sangachal Town and Umid lies above the average for the Garadagh District.

Primary and secondary sources of income (AZN) are presented by community, in Table 7.17 and Table 7.18.

**Table 7.17 Primary Sources of Income in the Communities within the Terminal Vicinity**

Primary Source of Income (AZN)	Sangachal Town	Umid	Azim Kend	Masiv 3
Employment in government	59%	22%	48%	44%
Employment in the oil and gas sector	11%	16%	0%	4%
Employment in another private sector	14%	32%	4%	12%
Raising livestock	0%	0%	12%	4%
Provision of services (e.g. tutoring, child care, transport, repairs etc.)	2%	4%	12%	4%
Entrepreneurship (not street trade)	1%	2%	0%	0%
Street trade/market	1%	0%	0%	4%
Pension and other social allowances	7%	10%	4%	12%
Support from relatives	4%	0%	4%	12%
Casual earnings (workman)	1%	14%	16%	4%

**Table 7.18 Secondary Sources of Income in the Communities within the Terminal Vicinity**

Secondary Source of Income	Sangachal Town	Umid	Azim Kend	Masiv 3
No secondary sources of income	52%	44%	72%	52%
Employment in government	1%	2%	0%	0%
Employment in the oil and gas sector	1%	6%	0%	0%
Employment in another private sector	6%	2%	0%	8%
Raising livestock	0%	0%	12%	0%
Provision of services (e.g. tutoring, child care, transport, repairs etc.)	3%	8%	0%	4%
Street trade/market	0%	0%	0%	4%
Pension and other social allowances	25%	22%	4%	12%
Support from relatives	6%	2%	4%	4%
Casual earnings (workman)	11%	22%	12%	8%
Serving in a religious office (mullah)	0%	0%	0%	4%

Combining the above data into a single set for all of the local communities indicates that over 50% of surveyed households do not have a secondary source of income. The data also indicates that there are significant differences in the sources of income between the local communities. Sangachal Town and Azim Kend are heavily reliant on government jobs for a primary source of household income which could be linked to the relatively high frequency of pensions from past roles in the public sector. The level of government employment in Umid

and Masiv 3 is relatively low and the percentage of households that draw a pension or other social allowance is also low.

Raising livestock is a source of primary and secondary income at Azim Kend and casual earnings are important at Umid and Azim Kend.

Data collected by the SSES provided an insight into the monthly household expenditure for food, utilities, land/rental costs, healthcare, education and transport. The results are presented in Table 7.19.

**Table 7.19 Monthly Household Expenditure in the Communities within the Terminal Vicinity**

Monthly Household Expenditure (AZN)	Food	Utilities	Land and/or house rental	Healthcare	Education	Transport
Minimum	50	2	1	5	5	2
Maximum	750	150	220	800	350	300
Average	237	48	27	63	51	57

The data shows that, in addition to food purchases, relatively equal proportions of average monthly household expenditure are dedicated to utilities, healthcare, education and transport. The cost of housing is comparatively low.

Data from the SSES collected information associated with the source of food purchases and this is presented in Table 7.20.

**Table 7.20 Source of Food Purchases in the Communities within the Terminal Vicinity**

Food Purchase	Sangachal Town	Umid	Azim Kend	Masiv 3	Total
Store or stall near your house	82	31	2	20	135
Store in Sahil community	23	33	6	8	70
Store in Gobustan community	10	1	18	2	31
Market in the community	5	5	3	3	16
From private traders who deliver foodstuff to the community by cars	4	2			6
Store in Sangachal Town			4		4
Store in the central Baku	2				2
Parents supply with foodstuff from rural area	1				1
Store in Masiv-3 community			1		1

The data indicates that more than 59% of households report that they purchase food from stores, stalls or markets within their own community, and a further 26% of households purchase food in Sahil. Very few households in Azim Kend buy food in their local area; more than half rely on stores in Gobustan community and a further 33% buy food in Sahil, Sangachal Town or Masiv 3.

## 7.5 Community Investment

The ACG, Shah Deniz, BTC, SCP and associated projects have played an important role in social development within the region. In addition to the direct economic benefit gained through local employment and use of local, regional and national businesses by BP, these previous projects have been implemented in parallel with substantial community development projects. These projects aim to support socio-economic development in the local communities, strengthening civil society through the active participation of local Non



Governmental Organisations (NGOs) and community-based organisations, and improve the relationship between local government and local populations.

BP is currently engaged in a variety of community investment programmes which use NGOs and other organisations as 'implementing partners'. Organisations which are currently implementing community investment programmes in partnership with BP within the Garadagh District are:

- GABA (Ganja Agribusiness Association);
- UMID (Human Development & Sustainable Income Generation Public Union);
- EPF (Eurasia Partnership Foundation);
- Center for Innovations in Education;
- Azerbaijan Community Development Research, Training & Resource Center (CD Center); and
- World Vision Azerbaijan.

A community investment programme recently completed was entitled: "The Youth Employment and the Expansion of Economic Opportunities Expansion Initiative". This initiative covered Sahil, Umid and Sangachal Town and focused on training young people in practical employment skills. The initiative lasted three years and ended in August, 2010. A total of 214 young people completed training courses. From this total, 145 were subsequently employed and 45 were enabled by Jump Start Economic Project grants to set up their own business. The budget of the project was US\$439,090, of which US\$66,404 was spent in 2010.

BP reported a gross social spend in Azerbaijan, by BP and its co-ventures, of approximately US\$M 42.2 between 2002 and 2010 (refer to Table 7.21)<sup>23</sup>.

**Table 7.21 BP / AIOC Social Spend 2002 to 2009 (US\$)**

2002	2003	2004	2005	2006	2007	2008	2009
600,000	2,710,000	8,640,000	6,290,000	6,750,000	7,390,000	6,430,000	3,398,650

## 7.6 Local Content Development

BP and its co-venturers' operations and projects expenditure in Azerbaijan in 2010 totalled \$1.03 billion, the same as 2009 (Table 7.22). This included a rise of 11% in direct spend with small and medium enterprises (SME) to \$147 million, an increase of 14% in spending with joint ventures to \$365.5 million, a fall of 4% in expenditure with state-owned companies to \$27.7 million and a decline of 11% to \$486 million in indirect local spend through foreign suppliers working in Azerbaijan.

The optimisation of suppliers in 2009 resulted in a focus on total cost ownership leading to cost reductions with joint ventures (JVs) who focused on value creation. This value creation will enable the JVs to provide sustainable business for many years and provide additional growth opportunities for national suppliers. In total, BP and its co-venturers did business with 281 companies in Azerbaijan in 2010, of which 221 (79%) were SMEs.

**Table 7.22 Local Content Spend 2006 to 2010 (US\$M)**

	2006	2007	2008	2009	2010
Small and Medium-Sized Enterprises (SMEs)	77	111	128	132	147
State-Owned Enterprises	60	43	37	30	28
Joint Ventures	520	450	408	321	366
Foreign Suppliers In-Country	826	891	737	546	486
<b>Total</b>	<b>1,483</b>	<b>1,495</b>	<b>1,310</b>	<b>1,029</b>	<b>1,027</b>

<sup>23</sup> BP Azerbaijan Sustainability Reports, 2004-2009.

## **8. Consultation and Disclosure**

### **Contents**

8.1	Introduction.....	2
8.2	Overview of Consultation and Disclosure Process .....	2
8.3	Scoping, Initial Stakeholder Engagement and Consultation.....	3
8.4	Draft ESIA Report Consultation .....	6
8.5	Consultation Under the Espoo Convention.....	6

### **List of Figures**

Figure 8.1	SD2 Infrastructure Project ESIA Consultation and Disclosure Process .....	3
------------	---	---

### **List of Tables**

Table 8.1	Key Issues Raised During Initial Consultation .....	6
-----------	---	---

## 8.1 Introduction

Stakeholder consultation is an important element of the Environmental and Socio-Economic Impact Assessment (ESIA) process. Soliciting, collating and documenting the opinions of potentially affected people and interested parties ensures that project design and the ESIA reflects the collective views of the stakeholder base.

This Chapter presents an overview of the consultation and stakeholder engagement relevant to the Shah Deniz 2 (SD2) Infrastructure Project and the process for ESIA disclosure.

Phased expansion of the Terminal has been undertaken over the past 10 years as part of the Azeri-Chirag-Guneshli (ACG) Phase 1, 2, 3 and SD Stage 1 Projects (refer to Chapter 1 Table 1.1). For each of these projects, extensive consultation with stakeholders and residents of the local communities was undertaken. Lessons learnt from previous projects' consultation has informed the SD2 Infrastructure Project consultation programme.

## 8.2 Overview of Consultation and Disclosure Process

The SD2 Infrastructure Project ESIA stakeholder consultation has:

- Made use of the consultation framework and methods established for other BP projects in Azerbaijan;
- Been developed with reference to accepted international guidance on expectations of ESIA consultation and disclosure;
- Considered the extent of consultation and disclosure undertaken in recent years;
- Incorporated recommendations made from a "lessons learned" review of earlier consultation programmes; and
- Acknowledged the requirement to engage with the following during the ESIA process:
  - National state bodies including:
    - The Ministry of Ecology and Natural Resources (MENR);
    - The Ministry of Culture and Tourism (MoCT); and
    - The Institute of Archaeology and Ethnography (IoAE).
  - The local community and other local stakeholders through a Stakeholder and Socio-Economic Survey (SSES);
  - BP AGT Region Teams; and
  - The SD2 Infrastructure Design Team.

Figure 8.1 below illustrates the SD2 Infrastructure Project ESIA consultation and disclosure process.

A Public Consultation and Disclosure Plan (PCDP) has been prepared for the main SD2 Project, which also covers the SD2 Infrastructure Project ESIA. The PCDP outlines the consultation and disclosure objectives and the national and international regulatory regime that project consultation and disclosure will follow, to ensure best practice approaches for the project.

The PCDP also sets out the:

- Process by which stakeholders are identified and consulted;
- Roles and responsibilities of the ESIA team of consultants and BP; and
- Process for lodging and responding to complaints.

**Figure 8.1 SD2 Infrastructure Project ESIA Consultation and Disclosure Process**

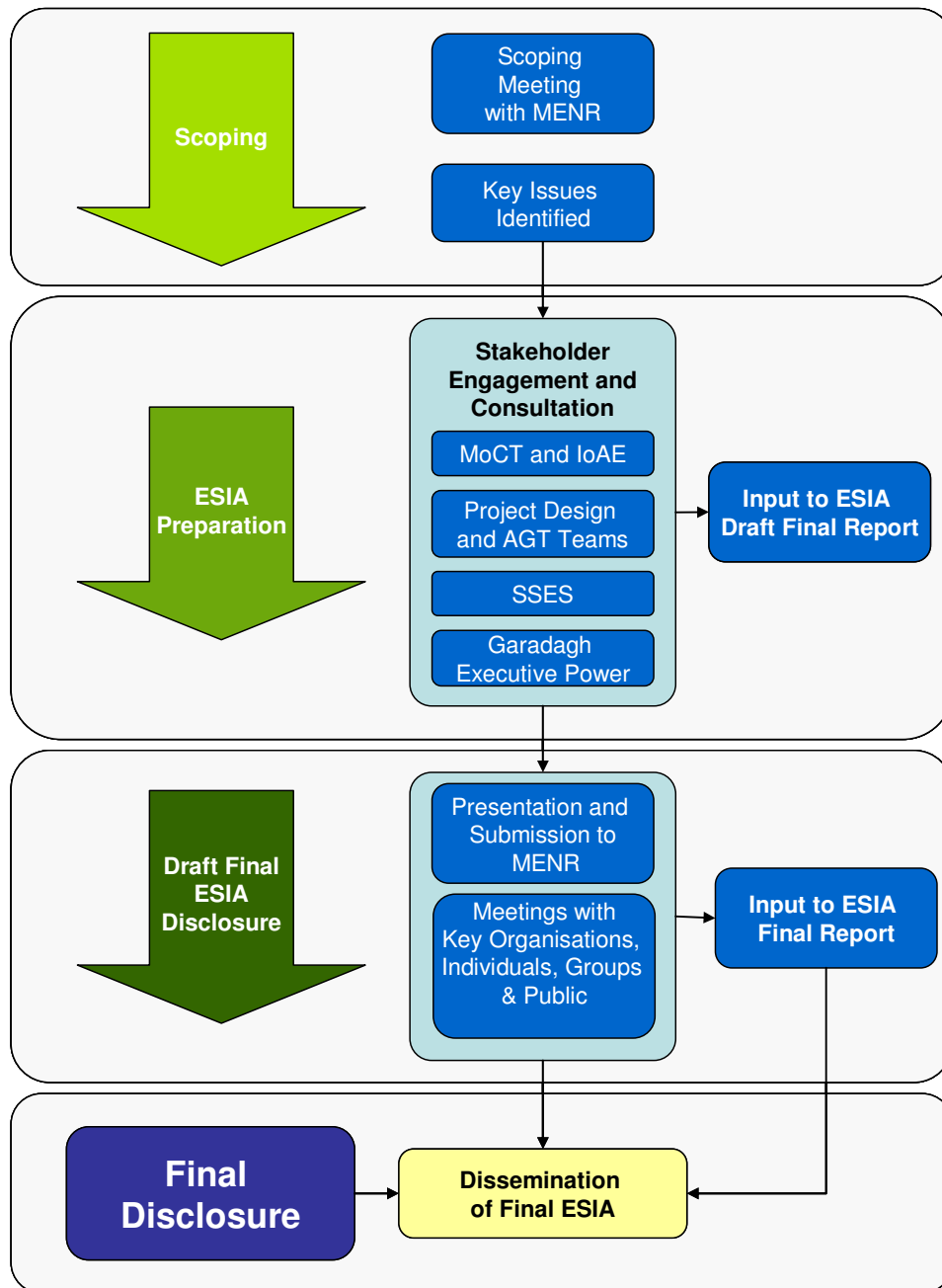

## 8.3 Scoping, Initial Stakeholder Engagement and Consultation

### 8.3.1 MENR Consultation

A meeting was held with the MENR on 17<sup>th</sup> March 2011 where an overview of the SD2 Infrastructure Project was presented including key activities, phasing and schedule. During the meeting the MENR confirmed that an ESIA should be prepared for the project and that the ESIA should ensure that the potential for cumulative impacts with other projects planned or under construction in the vicinity of the Terminal should be assessed. The MENR did not define the projects which the ESIA should include as part of the cumulative assessment.

### **8.3.2 Ministry of Culture and Tourism and Institute of Archaeology and Ethnography**

An initial meeting was held with the IoAE on 12<sup>th</sup> May 2011. This was followed by a meeting on 2<sup>nd</sup> June 2011 which was attended by MoCT representatives and included a site visit to a number of locations in the Terminal vicinity including the Caravanserai. At both meetings an overview of the proposed project activities and areas potentially affected were discussed.

The key issues raised from the meetings were:

- It was agreed that an archaeological walkover survey of the SD2 Infrastructure area should be completed pre-construction to confirm the presence/absence of any archaeological assets following the initial survey completed in 2001;
- The presence of a sand cave (located along the shoreline to the south of Terminal), a known protected monument, was highlighted. Potential project impacts and associated mitigation should be considered; and
- It was confirmed that BP will require MoCT approval for the project.

### **8.3.3 AGT Region Teams**

The scope of the ESIA has been informed by the AGT Region Environmental Team's extensive knowledge of existing environmental conditions in the Terminal vicinity. Monitoring has been ongoing since 1996 and formed part of the Integrated Environmental Monitoring Programme (IEMP) since 2004. The Environmental Team have therefore provided input to identify the key environmental issues of concern and inform the requirement for additional survey work to be completed as part of the ESIA.

### **8.3.4 SD2 Infrastructure Design Team**

Consultation with SD2 Infrastructure Design Team has been ongoing throughout the preparation of the ESIA.

An Environmental Impacts Identification (ENVIID) workshop was held in May 2010 based on the early SD2 Infrastructure Project design and options being considered. The workshop was led by the design contractor's environmental advisor and attended by members of the BP Project Team and the ESIA Team. During the workshop, aspects and impacts, existing control measures and recommendations for additional mitigation (where necessary) were identified based on a review of the road and camp options being considered at the time.

An equivalent Social Impacts Identification (SOCIID) workshop, following a similar methodology to the ENVIID but focused on potential socio-economic aspects and impacts, was held in September 2010. This workshop was held in Azerbaijan and attended by members of the AGT Region Communications and External Affairs (C&EA) Team. The resulting ENVIID and SOCIID registers have been used to inform the scope of this ESIA.

### **8.3.5 Stakeholder and Socio-Economic Survey**

A SSES was completed during preparation of the draft ESIA with the following objectives:

- Provide comprehensive and up-to-date socio-economic data for the SD2 Infrastructure Project and main SD2 Project ESIA's to enable a credible and technically robust ESIA to be conducted that meets BP Group and international best practice standards;
- Enable a clear understanding of prevailing demographic and socio-economic conditions; local development needs, capacities, priorities and concerns within the 4 communities of Sangachal Town, Umid, Azim Kend and Masiv 3;
- Identify the potential for and extent of, physical resettlement and economic displacement associated with the SD2 Infrastructure Project;
- Enable an assessment of the current and future role local stakeholder organisations could have in relation to BP partnering opportunities and community investment programmes;

- Disclose information associated with the SD2 Project to enable credible discussion of the impact to local people associated with industrial operations (including Terminal operations); and
- Establish a basis against which to monitor: (i) social change during the lifetime of the SD2 Project; and (ii) the effectiveness of impact management strategies designed during the ESIA process.

The SSES, undertaken by in country socio economic specialists, involved the following activities:

- **Household surveys:** Completion of 200 household surveys in Umid (25), Sangachal (100), Azim Kend (25) and Masiv 3 (25). The aim of the survey is to collect socio-economic and perception data directly from project-affected households, and to provide information on family conditions; access to community services and infrastructure; economic activity and livelihoods; and views on BP's historical community relations process;
- **Focus Groups:** Completion of 12 Community Focus Groups (3 in each of the 4 settlements). The topic areas for the Community Focus Groups include:
  - General community issues;
  - Women's issues; and
  - Youth issues.
- **Stakeholder Interviews:** A stakeholder identification process was undertaken to determine potentially affected stakeholders at a local, regional and national level. The SSES included 66 completed interviews with key stakeholders including national and local government, local business and non governmental organisations (NGOs). The aim of the interviews was to gather information associated with stakeholder roles and capacities and local development needs and priorities. Industrial facilities in the vicinity of the Terminal were also asked to provide details regarding emissions and discharges and future plans for expansion or upgrade.

Information disclosed publicly during the SSES included:

- Displaying posters in Azeri language in public information centres, municipality offices and community centres to request attendance at future community briefings;
- Using slide presentations at community briefings held in public buildings in Sangachal, Umid, Azim Kend and Masiv 3; and
- Distribution of community information leaflets to all individuals attending community briefings and those participating in community focus groups and household surveys.

The concerns raised by local people were recorded during the SSES and taken into consideration during preparation of the draft SD2 Infrastructure Project ESIA.



### 8.3.6 Key Issues Raised During Initial Consultation

Key issues raised during the SD2 Infrastructure Project ESIA initial consultation are listed in Table 8.1 below.

**Table 8.1 Key Issues Raised During Initial Consultation**

Concern	Raised By	Chapter Reference where Addressed
Potential cumulative impacts associated with other projects planned or under construction in the vicinity of the Terminal.	MENR	Chapter 11 Section 11.3
Preconstruction archaeological assessment	MoCT and IoAE	Chapter 9 Section 9.7
Impacts to sand cave	MoCT and IoAE	Chapter 9 Section 9.7
Dust and odour impacts	Local residents as part of SSES	Chapter 9, Table 9.2 and Section 9.3.2
Poor access to and availability of employment	Local residents as part of SSES	Chapter 10, Sections 10.4 , 10.5 and 10.9
Poor condition of local roads	Local residents as part of SSES	Chapter 10, Section 10.7

### 8.4 Draft ESIA Report Consultation

As per the UNDP Handbook for EIA Process in Azerbaijan, the Draft ESIA report was submitted to the MENR and simultaneously released to public and stakeholder groups for comment. As part of the Draft ESIA consultation process, public meetings were held in Azim Kend ,Sangachal Town and Umid during October 2011. The public meeting comments were recorded and are provided as Appendix 8A.

Copies of the Draft ESIA Report, in English, Russian and Azeri, were also made publicly available at locations including:

- BP website;
- Public information centres at Sangachal, Umid and Sahil;
- Aarhus Public Environmental Information Centre, Baku;
- Baku Information Education Centre;
- Public libraries in Sangachal and Sahil;
- BP Hyatt, Natavan and Villa Petrolea receptions, Baku;
- BP Energy Centre at Sangachal Terminal;
- M.F.Akhundov State Library, Baku; and
- Scientific Library of the Academy of Sciences of Azerbaijan.

Comments received on the Draft ESIA report were collated, analysed and responses issued where relevant. The ESIA was subsequently revised and finalised for MENR approval.

### 8.5 Consultation Under the Espoo Convention

As a signatory to the Convention on Environmental Impact Assessment in a Transboundary context (i.e. the Espoo Convention), the Azerbaijan Government is obliged to provide early notification to countries that may be subject to transboundary impacts as a result of a development within Azerbaijan.

Potential transboundary impacts, including potential impacts associated with GHG emissions are presented in Chapter 11 of this ESIA and will be discussed with the MENR as part of the ESIA disclosure process.

## 9. Environmental Impact Assessment, Mitigation and Monitoring

### Contents

9.1	Introduction.....	2
9.2	Scoping Assessment.....	2
9.3	Impacts to the Atmosphere .....	6
	9.3.1 Emissions From Onsite and Offsite Construction Plant and Vehicles .....	6
	9.3.2 Dust Due to Surface Soil Layer Removal and Spoil Movement .....	8
9.4	Impacts to the Terrestrial Environment (Noise).....	11
	9.4.1 Construction Noise.....	11
9.5	Impacts to the Terrestrial and Coastal Environment (Ecology).....	17
	9.5.1 Impacts to Ecology Due to Earthworks .....	17
9.6	Impacts to the Terrestrial Environment (Soil, Groundwater and Surface Water).....	21
	9.6.1 Excavation Works and Ground Disturbance.....	21
9.7	Impacts to the Terrestrial & Coastal Environment (Cultural Heritage).....	23
	9.7.1 Impacts to Cultural Heritage Due to Earthworks and Piling.....	23
9.8	Summary of SD2 Infrastructure Project Residual Environmental Impacts .....	26

### List of Figures

Figure 9.1	Modelled Increase in Short Term (24 hour) PM <sub>10</sub> Emissions at Ground Level Due to Surface Soil Layer Removal and Spoil Movement .....	10
Figure 9.2	Predicted Noise Levels (Realistic Scenario) at Sangachal (Onsite Construction Plant and Vehicles) .....	13

### List of Tables

Table 9.1	Structure of SD2 Infrastructure Project Impact Assessment .....	2
Table 9.2	“Scoped Out” SD2 Infrastructure Project Routine and Non-Routine Activities .....	3
Table 9.3	“Assessed” SD2 Infrastructure Project Routine and Non-routine Activities .....	5
Table 9.4	Event Magnitude .....	7
Table 9.5	Human Receptor Sensitivity.....	8
Table 9.6	Impact Significance .....	8
Table 9.7	Event Magnitude .....	11
Table 9.8	Impact Significance .....	11
Table 9.9	Noise Levels at Sensitive Receptors Associated with Piling Activities .....	14
Table 9.10	Worst Case Construction Noise Levels at Receptors (All Construction Activities).....	15
Table 9.11	Event Magnitude .....	15
Table 9.12	Human Receptor Sensitivity.....	15
Table 9.13	Biological/Ecological Receptor Sensitivity .....	16
Table 9.14	Impact Significance .....	16
Table 9.15	Event Magnitude .....	19
Table 9.16	Biological/Ecological Receptor Sensitivity .....	20
Table 9.17	Impact Significance .....	21
Table 9.18	Event Magnitude .....	22
Table 9.19	Receptor Sensitivity (Soil).....	23
Table 9.20	Receptor Sensitivity (Surface Water).....	23
Table 9.21	Impact Significance .....	23
Table 9.22	Event Magnitude .....	25
Table 9.23	Receptor Sensitivity .....	25
Table 9.24	Impact Significance .....	26
Table 9.25	Summary of SD2 Infrastructure Project Residual Environmental Impacts .....	26

## 9.1 Introduction

For all phases of the Shah Deniz 2 (SD2) Infrastructure Project, Activities and Events have been determined based on the Base Case Design described in Chapter 5: Project Description; and the potential for Interactions with the environment identified.

In accordance with the impact assessment methodology (see Chapter 3), ESIA Scoping has been undertaken to identify selected Activities that may be “scoped out” from the full environmental impact assessment process based on Event Magnitude and the likely Receptor Interaction. In addition, existing controls and mitigation have been identified. These include:

- Existing operational procedures which are applicable to the SD2 Infrastructure Project and procedures for similar projects used to ensure that activities are consistent with environmental expectations; and
- Feedback from previous ACG and SD construction projects (which have included works at the Terminal) including ambient monitoring of environmental performance and/or impacts during these projects.

Those Activities that have not been scoped out have been assessed on the basis of Event Magnitude and Receptor Sensitivity, taking into account the existing controls and mitigation, and impact significance determined. Monitoring and reporting undertaken to confirm that these controls are implemented and effective, as well as additional mitigation and monitoring to further minimise impacts, are also described.

Assessments of socio-economic, cumulative and transboundary impacts and accidental events have also been undertaken and are provided in Chapters 10 and 11 respectively. The structure of the impact assessment within this ESIA is provided within Table 9.1 below.

**Table 9.1 Structure of SD2 Infrastructure Project Impact Assessment**

Chapter	Title	Content
9	Environmental Impact Assessment, Mitigation and Monitoring	<ul style="list-style-type: none"> <li>• Scoping Assessment of SD2 Infrastructure Project Activities, Events and Interactions.</li> <li>• Identification of existing controls, mitigation, monitoring and reporting.</li> <li>• Environmental impact assessment of SD2 Infrastructure Project activities based on:                             <ul style="list-style-type: none"> <li>○ Event Magnitude; and</li> <li>○ Receptor Sensitivity.</li> </ul> </li> <li>• Identification of any additional mitigation measures.</li> </ul>
10	Socio-economic Impact Assessment, Mitigation and Monitoring	Assessment of socio-economic impacts.
11	Cumulative, Transboundary and Accidental Events	Assessment of cumulative and transboundary impacts (including impacts associated with greenhouse gas (GHG) emissions) and impacts arising from accidental events (including oil spills and spill management).
12	Environmental and Social Management	Description of the SD2 Infrastructure Project Environmental and Social Management Plans including waste management plans and procedures.

## 9.2 Scoping Assessment

The SD2 Infrastructure Project Activities and associated Events that have been “scoped out” due to their limited potential to result in discernable environmental impacts are presented in Table 9.2 (see Appendix 9A for all SD2 Infrastructure Project Activities, Events and Interactions). The scoping process has used judgement based on prior experience of similar Activities and Events, especially with respect to earlier ACG and SD construction activities at the Terminal. In some instances, scoping level quantification/numerical analysis has been used to justify the decision. Reference is made to relevant quantification, analysis, survey and/or monitoring reports in these instances.

**Table 9.2 “Scoped Out” SD2 Infrastructure Project Activities**

ID	Activity / Event	Phases	Ch. 5 Project Description Reference	Justification for “Scoping Out”
A2-R	Construction vehicle movements (offsite) (noise)	All Phases	-	<ul style="list-style-type: none"> <li>Construction traffic associated with the SD2 Infrastructure Project is expected to use the Baku-Salyan Highway during the construction period.</li> <li>Project contribution to traffic flows estimated to peak at 162 vehicle movements per day between May and October 2012 (Chapter 5 Table 5.5), which represents approximately 1.62% of existing traffic flows.</li> <li>Screening undertaken (refer to Appendix 9D) indicates the estimated increase in noise levels at sensitive receptors<sup>1</sup> will be no more than 1 dB(A), which will not be perceptible.</li> <li>A Community Interaction and Social Impact Management Plan will be implemented and maintained as a mechanism of communicating with the community and responding to community grievances.</li> <li>Increase in traffic noise due to offsite construction vehicles associated with the SD2 Infrastructure Project likely to be indiscernible at sensitive receptors<sup>1</sup>.</li> </ul>
A5-R	Drainage management works associated with wadi clearance and new drainage channels - alterations to surface water	Phase 3	5.5.3	<ul style="list-style-type: none"> <li>Drainage management works and above ground structural groundworks associated with the SD2 Infrastructure Project will result in alterations in surface water flows in the vicinity of the Terminal.</li> <li>Hydrological modelling has been undertaken to determine the flow conditions and flood risk prior to and following the SD2 Infrastructure works in the Terminal vicinity (refer to Appendix 9E).</li> <li>Modelling has shown that both prior to and following the SD2 Infrastructure works, Sangachal Town and Sangachal Power Station, which both lie significantly above the level of a major flood event<sup>2</sup>, are not at risk of flooding.</li> <li>Under existing conditions, sections of the railway and highway are currently at risk of flooding during a major flood event. Modelling showed that the SD2 Infrastructure project works not increase the likelihood or severity of the existing flood risk in these locations.</li> <li>The Caravanserai, a State protected monument located to the south of the Terminal, was shown to be located in an area which, at its lowest point, is very close to the level of a major flood event. The modelling demonstrated that the SD2 Infrastructure works are predicted to result in a negligible change to flood levels at this location (&lt;2mm increase).</li> <li>Overall, risk of flooding at key receptors was shown to either marginally reduce or remain largely unchanged following the SD2 Infrastructure works.</li> </ul>
A6-R	Above ground structural groundworks including construction of road embankments, flood protection berm and culvert works - alterations to surface water	Phases 3 & 4	5.5.3 & 5.5.4	<ul style="list-style-type: none"> <li>Above ground structural works will include the flood protection berm and access road embankments (elevated across the low lying wetland area to provide at-grade access to the Terminal). Culverts will be located under the access road and therefore will not be visible at distance.</li> <li>Berm and elevated access road expected to be indiscernible in the view from sensitive receptors<sup>1</sup>.</li> <li>No permanent or temporary structure planned to be more than 10m in height.</li> <li>Structures associated with construction camp and construction facilities will be highest (&lt;10m).</li> <li>Analysis undertaken to determine visibility from Azim Kend, Masiv 3, Sangachal and Umid (Appendix 9B)<sup>3</sup>.</li> <li>Demonstrates that structures will not visible from either Sangachal Town or Azim Kend.</li> <li>Very limited visibility of structures from Umid and Masiv 3. The areas where the analysis shows there may be some visibility are predominately located at the furthest point from the Terminal and would be obstructed by buildings between the community and the new structure.</li> </ul>
A6-R	Above ground structural groundworks works including construction of road embankments, flood protection berm and culverts - visual impact	Phases 3, 4 & 6	5.5.3, 5.5.4 & 5.5.6	<ul style="list-style-type: none"> <li>Above ground structural works will include the flood protection berm and access road embankments (elevated across the low lying wetland area to provide at-grade access to the Terminal). Culverts will be located under the access road and therefore will not be visible at distance.</li> <li>Berm and elevated access road expected to be indiscernible in the view from sensitive receptors<sup>1</sup>.</li> <li>No permanent or temporary structure planned to be more than 10m in height.</li> <li>Structures associated with construction camp and construction facilities will be highest (&lt;10m).</li> <li>Analysis undertaken to determine visibility from Azim Kend, Masiv 3, Sangachal and Umid (Appendix 9B)<sup>3</sup>.</li> <li>Demonstrates that structures will not visible from either Sangachal Town or Azim Kend.</li> <li>Very limited visibility of structures from Umid and Masiv 3. The areas where the analysis shows there may be some visibility are predominately located at the furthest point from the Terminal and would be obstructed by buildings between the community and the new structure.</li> </ul>
A11-R	Erection of temporary structures (e.g. temporary rail crossing gatehouse, security facilities, initial site compound offices) - visual impact			
A12-R	Erection of permanent structures (e.g. construction camp/facility structures) - visual impact			

<sup>1</sup> Sangachal Town, Umid, Azim Kend and Masiv 3.

<sup>2</sup> Major flood event is defined as 1 in 100 year flood.

<sup>3</sup> The analysis is limited to terrain and does not take account of existing structures therefore providing a worst case assessment.

ID	Activity / Event	Phases	Ch. 5 Project Description Reference	Justification for "Scoping Out"
A9-NR	Sewage treatment discharges (following commissioning of SD2 STP)	Phase 4	5.5.4	<ul style="list-style-type: none"> <li>Prior to completion of the STP, sewage will be sent to septic tanks and collected by road tanker for treatment and disposal to a licensed municipal STP plant.</li> <li>The new STP will commence operation following completion and commissioning. The STP is designed to serve the SD2 construction area and facilities.</li> <li>During the SD2 Infrastructure Project the STP will treat sewage generated by the SD2 Infrastructure workers (maximum of 700 people).</li> <li>Sewage will be treated to comply with applicable project standards 4.</li> <li>Treated sewage will be used for irrigation or dust control (preferred option) (residual chlorine content less than 1mg/l) or discharged to the wadi system (residual chlorine content less than 0.2mg/l).</li> <li>Residual chlorine content will be measured daily.</li> <li>Samples are taken from the sewage discharge outlet and analysed monthly for applicable project standard parameters<sup>4</sup>.</li> <li>Sewage sludge will be stored in designated containers for collection. No sewage sludge shall be discharged.</li> <li>Sewage and sludges will not be stored for longer than five days and sludge will not be allowed to become septic.</li> <li>Results from effluent monitoring will be submitted to the MENR at an agreed frequency.</li> </ul>
A10-R	Construction plant/vehicle refuelling	All Phases	-	<ul style="list-style-type: none"> <li>Vehicle refuelling will be undertaken in designated areas or using mobile bowzers.</li> <li>A refuelling procedure will be used which details the pre-checks, level indication monitoring, provision of temporary containment and drip trays, communication, training and spill kit requirements.</li> <li>The dedicated refuelling area associated with the project will be located within a bund capable of holding 110% capacity.</li> </ul>
A13-R	Grit blasting and painting of construction camp/facility structures	Phase 6	5.5.6	<ul style="list-style-type: none"> <li>Grit blasting and painting are required for the construction camp/facilities structures.</li> <li>Grit-blasting activities where practical shall be undertaken in enclosed buildings fitted with an air filtration system with the filters being regularly cleaned.</li> <li>Preference to use garnet for grit blasting which is inert, non-hazardous and suitable for disposal under EU legislation in a non-hazardous landfill.</li> </ul>
A14-R	Use of temporary lighting	All Phases	-	<ul style="list-style-type: none"> <li>Under normal conditions, work areas will not be lit outside of working hours unless for safety/security reasons.</li> <li>The existing Terminal is heavily lit (refer to Appendix 9B) and the existing lighting located around its perimeter would dominate any light associated with the main SD2 Infrastructure Project.</li> <li>Except for the access road works, no significant works are proposed immediately adjacent to the main Highway.</li> <li>The existing topography in the Pipeline Landfall Area limits the potential for light spill to the shoreline and Sangachal Bay.</li> <li>A lighting strategy will, however, be implemented which will include measures to minimise light spillage, glare to the community, road users and the shoreline.</li> </ul>
A15-R	Waste generation	All Phases	-	<ul style="list-style-type: none"> <li>Waste will be segregated at source, stored and transported in fit for purpose containers.</li> <li>Waste will be managed in line with the principles described in Chapter 12.</li> <li>Waste Minimisation and Management Plans will be established and all waste transfers controlled and documented.</li> <li>BP will manage the collection, transportation, treatment, disposal and storage of waste generated during the project - the destinations of the waste types is provided in Chapter 5, Table 5.8.</li> </ul>

<sup>4</sup> pH (6-9), 5 day BOD of less than 20mg/l, total coliform <400MPN (Most Probable Number) per 100ml, COD of less than 100mg/l, suspended solids of less than 30mg/l and residual chlorine less than 1mg/l (used for irrigation) or less than 0.2mg/l (discharge to the environment).

ID	Activity / Event	Phases	Ch. 5 Project Description Reference	Justification for "Scoping Out"
A16-R	Discharge from oil/water separator systems to wadi system			<ul style="list-style-type: none"> <li>Runoff from parking areas, the refuelling area and hazardous areas (e.g. fuel/chemical areas) will be routed to dedicated oil water separation systems.</li> <li>The oil water separation systems will be designed to treat water to applicable oil water standards<sup>5</sup>.</li> </ul>
A17-R	Leak test of construction camp drainage pipework	Phase 6	5.5.6	<ul style="list-style-type: none"> <li>It is possible that leak testing and super chlorination of the construction camp drainage pipework may be undertaken.</li> <li>Effluent from the pipework testing and chlorination will meet the applicable sewage<sup>6</sup> and oil water standards<sup>5</sup>.</li> <li>Following completion of leak testing, effluent will be preferentially used for dust suppression or discharged to the wadi system.</li> </ul>
A18-R	Installation and use of permanent lighting (access road, construction camp and construction facilities)	Phase 6	5.5.6	<ul style="list-style-type: none"> <li>Permanent lighting will be installed along the access road and around the construction camp and construction facilities.</li> <li>Lighting scheme should be consistent with ILE lighting guidelines.</li> <li>The existing Terminal is heavily lit (refer to Appendix 9B). Lighting associated with the SD2 Infrastructure Project would be indistinguishable from the current lighting environment.</li> </ul>

The SD2 Infrastructure Project routine and non-routine Activities and their associated Events assessed in accordance with the full impact assessment process are presented in Table 9.3.

**Table 9.3 "Assessed" SD2 Infrastructure Project Activities**

ID	Activity	Phases	Ch. 5 Project Description Reference	Event	Event Category
A1-R	Operation of construction plant and vehicles including diesel generators (onsite)	All phases	-	Emissions to atmosphere (non GHG) <sup>1</sup>	Onsite construction plant and vehicles
				Noise	
				Indirect effect/disturbance to wildlife	
A2-R	Construction vehicle movements (offsite)	All phases	-	Emissions to atmosphere (non GHG) <sup>1</sup>	Offsite construction vehicles
				Indirect effect/disturbance to wildlife	
				Disturbance/indirect effect to wildlife	
A3-R	Removal of surface soil layer and vegetation	Phases 1 & 3	5.5.1, 5.5.3	Loss of habitat	Surface soil layer removal and spoil movement
				Potential disturbance/damage to cultural heritage	
				Dust generation	
				Disturbance/indirect effect to wildlife	
A4-R	Movement and temporary storage of spoil	Phase 3	5.5.3	Dust generation	Surface soil layer removal and spoil movement
				Potential mobilisation of contamination	
				Potential disturbance/damage to cultural heritage	
A5-R	Drainage management works associated with wadi clearance and new drainage channels	Phase 3	5.5.3	Potential mobilisation of contamination	Drainage management works
				Disturbance/indirect effect to wildlife	
				Loss of habitat	
				Potential disturbance/damage to cultural heritage	
A7-R	Piling associated with installation of pipeline crossings	Phase 4	5.5.4	Noise	Piling activities
				Potential disturbance/damage to cultural heritage	
A8-R	Test piling	Phase 5	5.5.5	Noise	Piling activities
				Potential disturbance/damage to cultural heritage	

Notes: <sup>1</sup> GHG emissions are discussed in Chapter 11.

<sup>5</sup> Less than 10 mg/l as a monthly average and less than 19 mg/l on a daily basis.

<sup>6</sup> pH (6-9), 5 day BOD of less than 20mg/l, total coliforms <400MPN (Most Probable Number) per 100ml, COD of less than 100mg/l, suspended solids of less than 30mg/l and residual chlorine less than 1mg/l.(used for irrigation) or less than 0.2mg/l.(discharge to the environment).

## 9.3 Impacts to the Atmosphere

### 9.3.1 Emissions From Onsite and Offsite Construction Plant and Vehicles

#### 9.3.1.1 Event Magnitude

Onsite Construction Plant and Vehicles are discussed in Chapter 5: Project Description Section 5.7.1. Table 5.4 presents the estimated number and type of onsite construction plant and vehicles for each phase of the SD2 Infrastructure work.

Offsite Construction Traffic is discussed in Chapter 5: Project Description Section 5.7.2. Table 5.5 presents the estimated number of daily 2-way offsite road vehicle movements associated with the SD2 Infrastructure Project.

Existing controls associated with emissions from onsite and offsite construction plant and vehicles include:

- Construction plant and vehicles shall be modern and well maintained in accordance with the written procedures based on manufacturer's guidelines, applicable industry code, or engineering standard to ensure efficient and reliable operation.
- Where practicable, mains electricity shall be used instead of mobile generators as a power source.
- All construction plant and vehicles shall be switched off whilst not in use and not left to idle.
- A Community Interaction and Social Impact Management Plan will be implemented and maintained as a mechanism of communicating with the community and responding to community grievances.

The atmospheric dispersion modelling undertaken for Onsite and Offsite Construction Plant and Vehicles is presented in Appendix 9C. The modelling focuses on NO<sub>x</sub> (which comprises nitrous oxide (NO) and nitrogen dioxide (NO<sub>2</sub>)) as the main atmospheric pollutant of concern, based on the larger predicted emission volumes as compared to other pollutants (i.e. SO<sub>x</sub> and PM<sub>10</sub>). Modelling of SO<sub>2</sub> and particulates was not deemed necessary as concentrations are expected to be very low (approximately 10 times less than NO<sub>2</sub> concentrations) based on efficient plant and vehicle operation, regular maintenance and planned use of good quality, low sulphur diesel.

Long term and short term NO<sub>2</sub> concentrations were modelled to assess the contribution of emissions from the onsite construction plant and vehicles in the context of the relevant standards for NO<sub>2</sub><sup>7</sup>. These standards are relevant to locations where humans are normally resident (i.e. residential locations) and do not apply to commercial locations and workers, which are subject to standards under separate occupational health requirements.

The modelling assessment was undertaken for the period January – September 2012 (i.e. when the largest and greatest number of plant will be operational). The assessment also conservatively assumed all plant would be operating at full load for each working day. The predicted NO<sub>x</sub> emission rate from all the plant was entered into the model as an area source, distributed across the centre of SD2 Infrastructure area. The background concentration of NO<sub>2</sub> (6 µg/m<sup>3</sup>) was determined from the air quality monitoring undertaken in the vicinity of Sangachal (refer to Chapter 6 Section 6.4.5).

The modelling demonstrated that, during the onsite construction activities, an increase in the mean annual and 1 hour NO<sub>2</sub> concentrations is predicted at the nearby receptor locations of less than 0.1 µg/m<sup>3</sup> due to onsite construction plant and vehicle activities. This represents less than 0.25 % of the annual average NO<sub>2</sub> limit value and less than 2% of the background NO<sub>2</sub> concentration.

---

<sup>7</sup> Applicable 1 hour average (short term) and annual average (long term) standards for NO<sub>2</sub> are 40 µg/m<sup>3</sup> and 200 µg/m<sup>3</sup> respectively.



Emissions associated with offsite vehicles were assessed considering the expected change in NO<sub>2</sub> concentrations due to the increase in traffic flows along the Baku-Salyan Highway associated with the project. The period when the highest offsite traffic flows are expected (May-October 2012) were modelled and it was conservatively assumed these traffic flows would continue for a calendar year. Concentrations were modelled at the nearest residential receptor to the highway to provide a worst case assessment, which is approximately 20m from the south-bound carriageway and 65m from the north-bound carriageway within Sangachal Town. The additional vehicle movements due to the SD2 Infrastructure Project were predicted to lead to a maximum increase in mean annual NO<sub>2</sub> concentration of 0.9 µg/m<sup>3</sup> at the nearest residential receptor to the highway in Sangachal Town, which represents 2.2% of the applicable air quality limit value<sup>8,9</sup>. At a distance of 150m from the highway, increases in NO<sub>2</sub> concentrations were predicted to be less than 0.1 µg/m<sup>3</sup>.

Table 9.4 presents the justification for assigning a score of 8, which represents a Medium Event Magnitude.

**Table 9.4 Event Magnitude**

Parameter	Explanation	Rating
<b>Extent/Scale</b>	Emissions associated with the project activities will not affect ambient air quality (i.e. increase concentrations by more than 0.1 µg/m <sup>3</sup> ) more than 500m from the SD2 Infrastructure works (onsite plant and vehicles) or more than 150m from the highway (offsite construction vehicles)	1
<b>Frequency</b>	Emissions will occur continuously.	3
<b>Duration</b>	Emissions will continue throughout the construction period.	3
<b>Intensity</b>	Modelled short and long term concentrations of key pollutant, NO <sub>2</sub> , are predicted to be significantly below (i.e. more than 50 times below) relevant ambient air quality standards.	1
<b>Total</b>		<b>8</b>

### 9.3.1.2 Receptor Sensitivity

#### *Human Receptors*

The nearest receptors to the Terminal (refer to Chapter 6 Figure 6.6) include residents of:

- Sangachal Town, approximately 1 km south west of the nearest SD2 Infrastructure works and within 20m of the Highway (at the closest residential location);
- Azim Kend/ Masiv 3, approximately 2.5 km west of the nearest SD2 Infrastructure works and more than 2 km from the Highway; and
- Umid, approximately 1 km south east of the nearest SD2 Infrastructure works and within 230m of the Highway (at the closest residential location).

Table 9.5 presents the justification for assigning a score of 4 to human receptors, which represents Medium Sensitivity.

<sup>8</sup> Applicable 1 hour average (Short term) and annual average (long term) standards for NO<sub>2</sub> are 40 µg/m<sup>3</sup> and 200 µg/m<sup>3</sup> respectively.

<sup>9</sup> Historically in Azerbaijan ambient concentrations of NO<sub>2</sub>, SO<sub>2</sub>, CO and PM<sub>10</sub> have also been assessed against specific 24 hour and 1 hour standards. These standards were not derived using the same health based criteria as the IFC, WHO and EU guideline values and the standards derived are not widely recognised. However, Appendix 9C includes an assessment of expected air quality concentrations against these standards for completeness. The modelling demonstrated that none of these standards would be exceeded during SD2 Infrastructure Project activities.

**Table 9.5 Human Receptor Sensitivity**

Parameter	Explanation	Rating
<b>Presence</b>	Nearest residential receptors (within Sangachal Town) are located within 500m of the highway (to be used by project construction traffic) and approximately 1km from the nearest SD2 Infrastructure works.	3
<b>Resilience</b>	Modelling results have confirmed that emissions from onsite and offsite construction plant and vehicles sources will not exceed air quality standards and local receptors are not considered to be vulnerable – existing NO <sub>2</sub> concentration are well below applicable standards.	1
<b>Total</b>		<b>4</b>



### 9.3.1.3 Impact Significance

Table 9.6 summarises impacts on air quality associated with onsite construction plant and vehicles.

**Table 9.6 Impact Significance**

Event	Event Magnitude	Receptor Sensitivity	Impact Significance
Emissions associated with onsite and offsite construction plant and vehicles	Medium	(Humans) Medium	<b>Moderate Negative</b>

It is considered that impacts are minimised as far as practicable and necessary through the implementation of the existing control measures as listed in Section 9.3.1.1.above and therefore no additional mitigation is required.

## 9.3.2 Dust Due to Surface Soil Layer Removal and Spoil Movement

### 9.3.2.1 Event Magnitude

Surface soil layer removal and spoil movement is discussed in Chapter 5: Project Description Section 5.5.3.

Existing controls associated with control of dust due to the SD2 Infrastructure works include:

- Vehicles shall travel at speeds that minimise dust and unpaved roads/tracks and road speeds will be established for different road surfaces.
- Speed limits shall be adhered to at all times.
- Construction activities shall be suspended if excessive dust arises and measures shall be taken to control ground prior to resuming activities.
- All onsite vehicle routes to be marked on the road surface.
- Off-road driving shall be prohibited outside of designated areas unless specifically authorised.
- The loads of all construction vehicles entering the site shall be covered.
- Drivers of onsite construction vehicles shall be provided with dust management training.
- Where off road access is required, routes will be chosen to minimise damage and return journeys will be made along the same routes.
- Where unsurfaced, the main access routes will be created using compacted well graded granular fill, appropriately designed to ensure good drainage to minimise the potential for erosion.
- All unsurfaced routes shall be regularly maintained to ensure the surface remains stable and compacted.
- All hardstanding areas (including paved roads) shall be regularly inspected to ensure as are kept clean of dust and mud.

- Dust management options will be assessed and will include recommendations for monitoring. Periodic audits will be undertaken to confirm effectiveness of measures to minimise dust. The audits will include observations of meteorological conditions including wind speed, direction and general weather conditions.
- A wheel washing facility shall be used for construction vehicles leaving the site.
- Spoil heaps to be inspected regularly to assess condition and potential to generate dust.
- Quantity and duration of spoil exposure will be minimised as far as possible and ground disturbing activities shall be sequenced to minimise the area disturbed at one time.
- Temporary or permanent stabilisation of exposed soils will be provided to prevent washout of spoil by rainfall and generation of dust.

The atmospheric dispersion modelling undertaken for the Surface Soil Layer Removal and Spoil Movement activities are presented in Appendix 9C. The modelling focuses on dust and PM<sub>10</sub> as the main atmospheric pollutant of concern. Dust refers to both suspended and deposited particulate matter up to 75 microns ( $\mu\text{m}$ ) in diameter and has the potential to create a public nuisance, through deposition of dust e.g. on vehicles, window sills etc. PM<sub>10</sub> is defined as particulate matter with an aerodynamic diameter of less than 10 microns ( $\mu\text{m}$ ) and is the result of a combination of man-made (construction work) and natural processes such as natural entrainment of particles by the wind periods of extended dry weather.

The potential drift distance of airborne particles is governed by the initial injection height of the particle, the terminal settling velocity, and the degree of atmospheric turbulence. Particles larger than about 100 microns ( $\mu\text{m}$ ) are likely to settle within 6 to 9 metres (m) from the emission source, with particles 30-100  $\mu\text{m}$  in diameter settling within 50-100m. Smaller particles, such as PM<sub>10</sub>, can travel several hundreds of metres from the source, sometimes up to 1km<sup>10</sup>.

The modelling undertaken assumed an emission rate of 100 milligrams dust per square metre per second ( $\mu\text{g}/\text{m}^2/\text{s}$ ) based on USEPA factors<sup>11</sup> and 20  $\mu\text{g}/\text{m}^2/\text{s}$  per PM<sub>10</sub> based on UK guidance<sup>12</sup>. It was estimated, based on Chapter 5 of the ESIA, that the most significant works would occur within the central part of the SD2 Infrastructure area over an area of approximately 140 hectares. PM<sub>10</sub> concentrations and dust deposition rates at receptors were then calculated by the model based on the expected emissions arising from this central area.

Modelled PM<sub>10</sub> concentrations were compared against applicable limit value and existing background concentrations. Dust deposition rates were compared to international guidance levels<sup>13</sup>.

### **PM<sub>10</sub> Concentrations**

The predicted increase in long term annual PM<sub>10</sub> concentrations at the nearest sensitive receptors are expected to range between 0.1- 0.3  $\mu\text{g}/\text{m}^3$ . This is between 0.5% and 1.5% of the limit value concentration. The increase in short term (24 hours) PM<sub>10</sub> concentrations (modelled as the 99<sup>th</sup> percentile) is slightly higher, due to the shorter averaging period associated with this limit value. Concentration increases between 1.17 and 3  $\mu\text{g}/\text{m}^3$  are predicted. Figure 9.1 shows the predicted increase in short term PM<sub>10</sub> emissions at ground level due to construction activities.

<sup>10</sup> United States Environmental Protection Agency (US EPA). AP 42, Fifth Edition Compilation of Air Pollutant Emission Factors, Volume 1: Stationary Point and Area Sources. Chapter 13.2 Fugitive Dust Sources.

<sup>11</sup> For heavy construction works within a semi-arid climate assuming soils with medium silt content.

<sup>12</sup> Quality of Urban Air Review Group (QUARG) (1996); Airborne Particulate Matter in the United Kingdom.

<sup>13</sup> Most stringent guidance levels of 133  $\mu\text{g}/\text{m}^2/\text{day}$  were used sourced from Australian guidance. No single international value exists.

**Figure 9.1 Modelled Increase in Short Term (24 hour) PM<sub>10</sub> Emissions at Ground Level Due to Surface Soil Layer Removal and Spoil Movement**

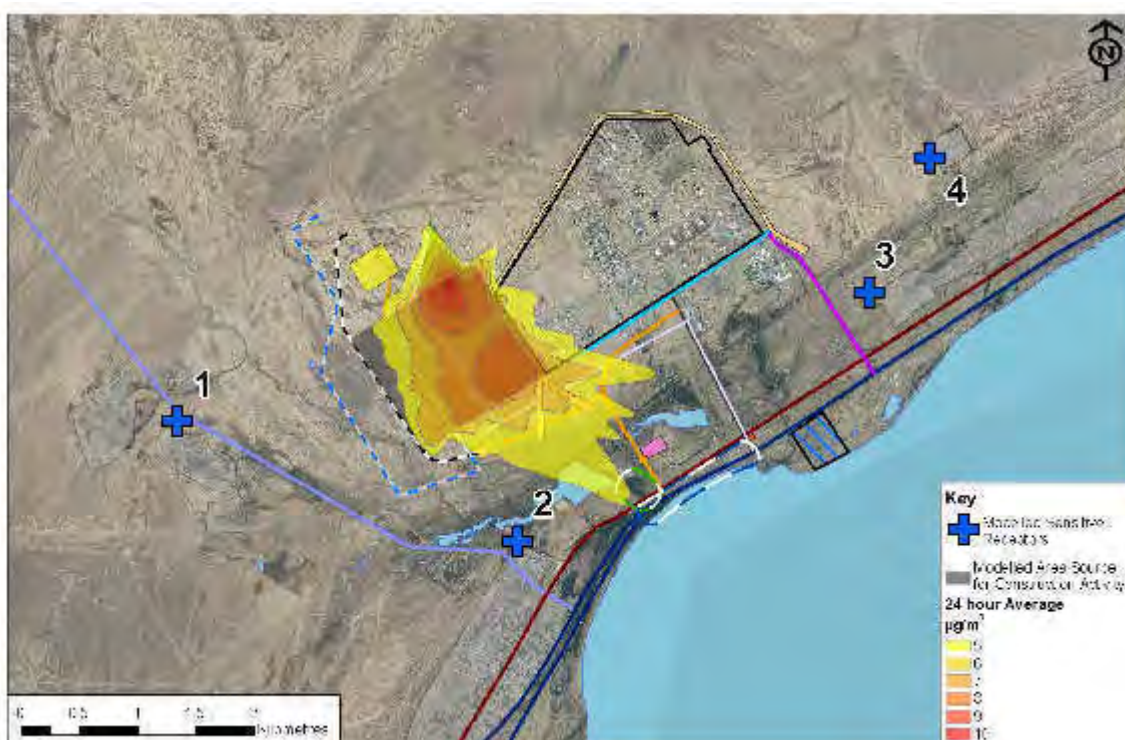

The figure shows that while the predominant wind direction is north (refer to Chapter 6 Figure 6.2), PM<sub>10</sub> concentrations at ground level appear to be influenced by wind from the north west. The sensitivity analysis undertaken within the modeling (refer to Appendix 9C) showed that high (e.g. 15m/s) and low (e.g. 5m/s) wind speeds result in similar short term PM<sub>10</sub> concentrations at receptors while average wind conditions (around 7-8m/s) result in higher concentrations (by a factor of 5). As Figure 6.2 shows, these average wind conditions tend to occur more frequently from the north west.

Worst case PM<sub>10</sub> concentrations, i.e. the highest concentrations obtained throughout the year (the 100<sup>th</sup> percentile) were also modelled and the results showed, under worst case conditions, there would be an estimated increase in the daily PM<sub>10</sub> concentration of 1.3 - 6.0 µg/m<sup>3</sup> at the modelled nearby sensitive receptor locations. This is well below the short term limit value of 50 µg/m<sup>3</sup>.

The impact on PM<sub>10</sub> concentrations associated with construction activities is therefore considered insignificant, and would be imperceptible in comparison with the background PM<sub>10</sub> concentration of 109 µg/m<sup>3</sup>.

### Dust Deposition

Annual average and maximum dust deposition rates were modelled. On an annual basis the modelling estimated a daily average dust deposition rate at sensitive receptors of between 1.7 and 9.8 mg/m<sup>2</sup>/day, which represents 1.2 – 7.4% of the guidance level (133 mg/m<sup>2</sup>/day). The maximum daily dust deposition rate was calculated as 132 mg/m<sup>2</sup>/day at Sangachal Town. This rate is comparable to the guidance limit value, however the modelling did not take into account the existing controls associated with dust minimisation as discussed above such as limiting vehicle speeds on unsurfaced roads, use of water to control dust from exposed surfaces and suspension of work should excessive dust levels arise. It is expected that, in general, the dust generated by the construction works will be imperceptible in the context of the existing, background levels of dust deposition that generally occur in semi-arid areas (estimated to be between 495-896 mg/m<sup>2</sup>/s)<sup>14</sup>.

<sup>14</sup> Wanquan Ta and Tao Wang (2004); 'Measurements of dust deposition in arid and semi-arid regions, China', American Society of Civil Engineers (ASCE) pp. 1-10.

Table 9.7 presents the justification for assigning a score of 8, which represents a Medium Event Magnitude.

**Table 9.7 Event Magnitude**

Parameter	Explanation	Rating
Extent/Scale	It is predicted that the PM <sub>10</sub> concentration and dust emissions from construction activities will be imperceptible at sensitive receptors	1
Frequency	Emissions will occur continuously.	3
Duration	Emissions will continue throughout the construction period.	3
Intensity	Modelled contribution to long and short term concentrations of key pollutant, PM <sub>10</sub> is predicted to be significantly lower (more than 15 times lower) than applicable limit values.	1
		<b>8</b>

### 9.3.2.2 Receptor Sensitivity

In terms of Emissions to Atmosphere, Receptor Sensitivity is considered to be the same as per Section 9.3.1.2 above; therefore Receptor Sensitivity is Medium, for human receptors.

### 9.3.2.3 Impact Significance

Table 9.8 summarises impacts on air quality (i.e. PM<sub>10</sub> concentrations) and dust nuisance impacts associated with surface soil layer removal and spoil movement.

**Table 9.8 Impact Significance**

Event	Event Magnitude	Receptor Sensitivity	Impact Significance
Emissions & dust associated with surface soil layer removal and spoil movement	Medium	Medium	<b>Moderate Negative</b>

It is considered that impacts are minimised as far as practicable and necessary through the implementation of the existing control measures as listed in Section 9.3.2.1 above and therefore no additional mitigation is required. A dust monitoring programme will be established prior to and during construction works and the results provided.

## 9.4 Impacts to the Terrestrial Environment (Noise)

### 9.4.1 Construction Noise

#### 9.4.1.1 Event Magnitude

#### Onsite Construction Plant and Vehicles

Onsite Construction Plant and Vehicle activities are discussed in Chapter 5: Project Description, Section 5.7.1. Table 5.4 presents the types of construction plant expected to be used during the SD2 Infrastructure Project. Figure 5.4 presents the indicative project schedule.

Existing controls associated with noise due to operation of onsite construction plant and vehicles include:

- Construction plant and vehicles shall be modern and well maintained in accordance with written procedures based on the manufacturer's guidelines, applicable industry code, or engineering standard to ensure efficient and reliable operation.
- Where practicable, mains electricity shall be used instead of mobile generators as a power source.

- A Community Interaction and Social Impact Management Plan will be implemented and maintained as a mechanism of communicating with the community and responding to community grievances.
- All construction plant and vehicles shall be switched off whilst not in use and not left to idle.
- Where possible communities shall be warned in advance of any particularly noise activities to be undertaken; when unavoidable, noisy operations shall be undertaken during normal daylight working hours.
- Onsite personnel will be trained in how to minimise noise.
- All vehicles and mechanical plant equipment will be fitted with effective exhaust silencers.
- Noisy plant will be located as far as possible from sensitive receptors and where appropriate and practical will be located behind barriers (for example, site huts, acoustic partitions etc.) to provide shielding in order to reduce noise levels at sensitive receptors.
- Compressors will be fitted with properly lined and sealed acoustic covers that are kept closed whenever in use and pneumatic percussive tools will be fitted with mufflers or silencers.
- Continuous noise emitting machinery will be housed in a suitable acoustic enclosure.
- Where practicable, rotary drills and bursters actuated by hydraulic, chemical or electrical power will be used for excavating hard or extrusive material.
- When selecting large plant that is used for extended periods preference will be given to plant that is compliant with EU Noise Directives 2000/14/EC and 2005/88/EC where possible.

Modelling was undertaken to estimate the increase in noise levels at receptors in the Terminal vicinity due to the onsite plant and vehicles (refer to Appendix 9D for full modelling assessment) at sensitive receptors (i.e. residential locations). The assessment was undertaken in accordance with guidance provided within BS5228:2009<sup>15</sup>. Source noise levels for the proposed onsite plant and vehicles were also derived from BS5228: 2009.

Modelling was undertaken based on a realistic scenario which reflects the expected typical construction activities (i.e. 50% of the plant and vehicles are operating at the works boundary and 50% within the centre of the SD2 Infrastructure area). Noise levels were determined with and without the flood protection berm in place. Based on the indicated schedule it is assumed that the flood protection berm will be in place from May 2012.

Noise levels were predicted across the construction period and results were compared to the existing ambient noise levels at the receptors (refer to Chapter 6 Section 6.4.6) and the noise limit value of 65dB, determined from BS5228: 2009<sup>16</sup>.

The results of the modelling showed that no exceedances are predicted at Azim Kend, Masiv 3, Umid or Sangachal Town. Highest noise levels were predicted at Sangachal Town (refer to Figure 9.2), where the noise limit value of 65dB is predicted to be just met. The noise limit value predicted however was lower than the existing average ambient noise level of 67dB(A). This implies that construction noise would not be significantly noticeable in the context of the existing noise levels in this location.

<sup>15</sup> British Standards Institute (BSi), (2009): 'BS5228 – Noise Vibration Control on Construction and open Sites', BSi, London.

<sup>16</sup> 65dB limit applicable Monday – Friday daytime (07:00 to 19:00) and Saturday (07:00 to 13:00).



**Figure 9.2 Predicted Noise Levels (Realistic Scenario) at Sangachal Town (Onsite Construction Plant and Vehicles)**

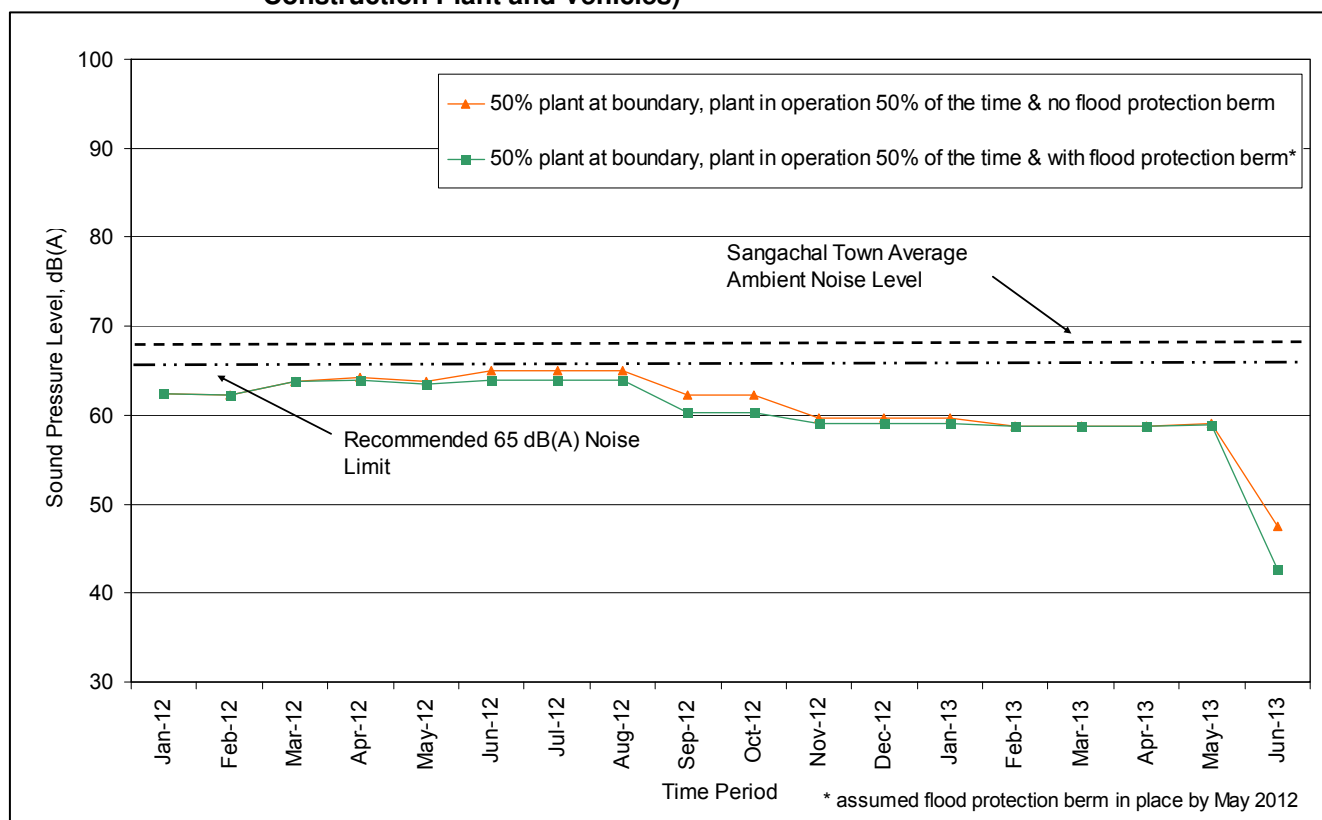

### Concrete Batching Plant

Noise associated with the concrete batching plant<sup>17</sup> was also modelled and the expected increase in noise levels at a sensitive receptors due to the plant operation calculated. The assessment showed, that even under worst case assumptions (100% load, 10 hours per day operation and plant located at the boundary of the SD2 Infrastructure area closest to the receptor), noise levels at receptors would range from 33dB(A) and 46dB (A) (at Umid and Sangachal Town respectively) and would not exceed current ambient levels or the 65dB noise limit at any receptor.

### Piling Activities

Piling activities are planned to comprise:

- Bored piling associated with installation of crossings under the new access road within the 3<sup>rd</sup> party pipeline corridor immediately to the south of the Terminal (refer to Chapter 5 Figure 5.8); and
- Piling trials either within or 100m from the boundary of the SD2 Expansion Area (refer to Chapter 5 Section 5.5.5).

Noise modelling has been undertaken (refer to Appendix 9D) to assess the impact of the piling activities to local receptors. The piling associated with access road crossings was assessed assuming use of up to 3 bored piling rigs and pneumatic hammers and an air compressor in location 1 (where the access road crosses the 3rd party pipeline corridor) and location 2 (in the vicinity of the western drainage channel outfall). It was conservatively assumed that the rigs would be operational 100% of the working day. Noise levels were predicted at Azim Kend, Umid and Sangachal Town.

<sup>17</sup> Not part of the Base Case Design but space is allocated should the decision be made to incorporate one into the design –see Chapter 5 Section 5.5.4.



Noise associated with piling trials was assessed based on the following four scenarios:

- Tubular piling at a location 100m from the north west corner of the SD2 Expansion Area;
- Pre cast concrete piling at a location 100m from the north west corner of the SD2 Expansion Area;
- Tubular piling at a location 100m from the south west corner of the SD2 Expansion Area; and
- Pre cast concrete piling at a location 100m from the south west corner of the SD2 Expansion Area.

The results obtained from the assessments are presented in Table 9.9.

**Table 9.9 Noise Levels at Sensitive Receptors Associated with Piling Activities**

Scenario	Type of Piling	Location	Predicted Noise Level (dB(A))			Limit Value (dB(A))
			Azim Kend	Umid	Sangachal	
<b><i>Bored Piling Associated with Pipeline Culverts</i></b>						
1	Rotary Bored	Location 1	54	52	60	65
2		Location 2	52	54	58	
<b><i>Trial Piling</i></b>						
1	Tubular	North west	45	39	45	65
2	Pre Cast Concrete		46	40	46	
3	Tubular	South west	44	40	49	
4	Pre Cast Concrete		45	41	50	

The modelling results indicate that no exceedances of the construction noise limit (65dB(A)) are predicted at any of the modelled receptors associated with piling activities.

### Concrete Breaking

It is anticipated that concrete breaking works may be required within the SD2 Expansion Area to remove existing areas of concrete from previous activities in the area (Chapter 5 Section 5.5.3). Modelling of expected noise levels at receptors associated with this activity was undertaken (refer to Appendix 9D) assuming both screening and no screening of the works. The results showed that the highest noise levels were estimated to be 50dB(A) (with screening) and 55dB(A) (without screening) at Sangachal Town and no exceedances of the construction noise limit (65dB(A)) were predicted at any of the modelled receptors.

### All Construction Noise

An assessment was undertaken to determine the likely worst case impacts should the period of highest onsite construction plant and vehicle activity, concrete breaking and the piling activities coincide (refer to Appendix 9D). Table 9.10 presents the results obtained.

**Table 9.10 Worst Case Construction Noise Levels at Receptors (All Construction Activities)**

Activity	Predicted Noise Level, dB(A)		
	Azim Kend (R1)	Sangachal (R2)	Umid (west) (R3)
Onsite construction plant and vehicles <sup>1</sup>	62	65	60
Concrete breaking within the SD2 Expansion Area	51	55	49
Pipeline crossing piling	54	60	52
Trial Piling (within the SD2 Expansion Area)	54	60	52
<b>Overall Noise Level</b>	<b>63</b>	<b>67</b>	<b>61</b>
<b>Existing Average Ambient Noise Level</b>	<b>52</b>	<b>67</b>	<b>55</b>

1. Includes concrete batching plant

The assessment showed that, under worst case assumptions, the limit value of 65 dB(A) would be met at Azim Kend and Umid but would be exceeded at Sangachal Town. At this receptor, however, it is predicted that the worst case noise level would be comparable to the existing ambient noise level of 67 dB(A), implying that construction noise would not be significantly noticeable in the context of the existing noise levels in this location. Noise levels, while below the relevant noise limit, are more likely to be noticeable at Azim Kend and Umid where existing ambient noise levels are lower.

Table 9.11 presents the justification for assigning a score of 8 to activities associated with construction noise, which represents a Medium Event Magnitude.

**Table 9.11 Event Magnitude**

Parameter	Explanation	Rating
<b>Extent/Scale</b>	Noise from construction works will travel to receptors greater than 1km from source. However, noise levels will be either similar to ambient levels or within the applicable noise limit value of 65dB. With existing control measures in place, it is expected that noise will not significantly affect locations greater than 500m from the boundary of the works.	1
<b>Frequency</b>	Noise will occur continuously.	3
<b>Duration</b>	Noise will continue throughout the construction period (with highest noise levels expected June – August 2012).	3
<b>Intensity</b>	Applicable noise limits or ambient noise levels (which ever is the greatest) will be met at all sensitive receptors throughout the construction works.	1
		<b>8</b>



**9.4.1.2 Receptor Sensitivity**

**Human Receptors**

Table 9.12 presents the justification for assigning a score of 3 to human receptors, which represents Medium Sensitivity.

**Table 9.12 Human Receptor Sensitivity**

Parameter	Explanation	Rating
<b>Presence</b>	Nearest residential receptors (within Sangachal Town) are located between 500m to 1km of the SD2 Infrastructure works.	2
<b>Resilience</b>	Modelling results have confirmed that construction noise, even under worst case assumptions, will not exceed applicable noise limits or ambient noise levels (which ever is the greatest). Local receptors are not considered to be vulnerable as the existing noise environment is considered typical of an industrial area.	1
<b>Total</b>		<b>3</b>



**Biological/Ecological Receptors**

Noise from onsite plant and vehicles has the potential to impact breeding birds. Of the bird species recorded during the 2008 and 2009 bird surveys in the Terminal vicinity (refer to Chapter 6 Section 6.4.7.4), a total of 23 species (approximately 50% of all species recorded) are considered to be resident (breeding and occurring all year round). Of these, five species<sup>18</sup> are ground nesting, and have been recorded in the semi-desert habitat in the vicinity of Sangachal Terminal and the SD2 Expansion Area. While the data collected during the 2008 and 2009 surveys does not include the precise locations of nests, the breeding bird species recorded do not tend to nest in the same location each year. It is therefore not appropriate to state the number of breeding individuals that use the SD2 Infrastructure area as this will vary from year to year. There is no evidence within the surveys completed to date to indicate that the habitat within the SD2 Infrastructure Area is of unique value to breeding birds.

Breeding birds are most sensitive to disturbance during the breeding season (typically mid March – end August). They are most sensitive to sudden unexpected and loud noise such as hammering. Studies have shown however that birds frequently become habituated to anthropogenic noise including construction noise with no recorded effect on behaviour or breeding success<sup>19</sup>. Equally impacts to breeding success due to noise impacts have also been recorded. The survey results obtained within the Terminal vicinity suggest that the breeding birds are habituated to the industrial noise from the Terminal and Highway traffic noise may likely also therefore adapt to construction noise.

Table 9.13 presents the justification for assigning a score of 3 to biological/ecological receptors, which represents Medium Receptor Sensitivity.

**Table 9.13 Biological/Ecological Receptor Sensitivity**

Parameter	Explanation	Rating
<b>Presence</b>	23 species of residential birds have been recorded during surveys in 2008 and 2009 in the Terminal vicinity; approximately 22% of these species are breeding birds. Of these, 5 ground nesting breeding bird species were identified. None of these species are rare or threatened.	1
<b>Resilience</b>	While ground nesting birds have been identified within the areas affected by the works there is no evidence to indicate that areas have unique value to these species. It is likely that birds in the area are already tolerant to existing industrial noise and would become habituated to construction noise. It is expected that any disturbance to ground nesting bird breeding would stabilise as they adapt to the construction noise and the ecological functionality of the overall ground nesting bird population will be maintained.	2
<b>Total</b>		<b>3</b>

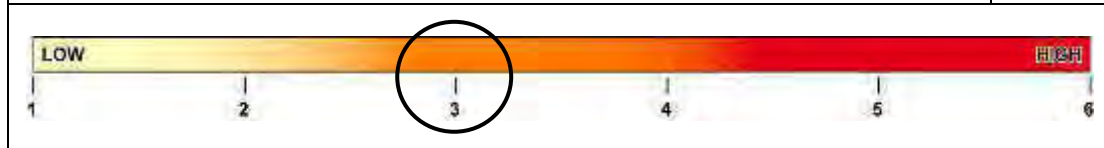

**9.4.1.3 Impact Significance**

Table 9.14 summarises impacts on noise associated with construction activities.

**Table 9.14 Impact Significance**

Event	Event Magnitude	Receptor Sensitivity	Impact Significance
Noise associated with construction activities	Medium	(Humans) Medium	<b>Moderate Negative</b>
		(Biological/Ecological) Medium	<b>Moderate Negative</b>

<sup>18</sup> These include Chukar *Alectoris chukar*, Red-capped lark *Calandrella cinerea*, Lesser short-toed lark *Calandrella rufescens*, Calandra lark *Melanocorypha calandra* and Crested lark *Galerida cristata*.

<sup>19</sup> Melissa Anne Lackey, (2009), Avian Response To Road Construction Noise With Emphasis On The Endangered Golden-Cheeked Warbler.

The assessment of total construction noise (Section 9.4.1.1 above) provides an estimate of the contribution of the planned project activities to construction noise levels from each project activity. The existing control measures presented above are focused on best practice measures to control noise from onsite construction plant and vehicles (the greatest contributor to noise at receptors as shown in Table 9.10). To appropriately control noise associated with planned piling and concrete breaking activities the following measures will also be adopted:

- Where practicable, portable acoustic screens will be used around pneumatic hammers used when undertaking concrete breaking; and
- The local community (Sangachal Town, Azim Kend and Masiv) will be informed of the proposed schedule and works prior to commencement of the trial piling activities with driven piles.

No additional measures to those listed in Section 9.4.1.1 are considered necessary. A noise monitoring programme will be established prior to and during construction works and the results provided externally.

## **9.5 Impacts to the Terrestrial and Coastal Environment (Ecology)**

### **9.5.1 Impacts to Ecology Due to Earthworks**

#### **9.5.1.1 Event Magnitude**

Earthworks associated with the SD2 Infrastructure Project comprise surface soil layer removal and spoil movement, drainage management works and Pipeline Landfall Area preparation.

Chapter 5 indicates that the surface soil layer and associated vegetation will be removed from:

- The footprint of the Initial Site Compound during Phase 1;
- The route of the Enabling Road (not including the existing EOP road) during Phase 2;
- The route of the new Terminal access road during Phase 3; and
- The SD2 Expansion, North Construction Camp and South Construction Facilities areas during Phase 3.

It is anticipated that the surface layer will be removed to a depth of approximately 0.15m and a total surface area of approximately 70 hectares (ha) of desert and semi-desert habitat will be affected.

While it is planned to use the stripped surface soil as non-structural fill material within the flood protection berm, it is intended that stripped vegetation (including the surface layer of earth held together by its roots) will be stored separately and where practicable used for re-vegetation. Where not practicable vegetation will be mulched and disposed of in a suitable manner.

As part of the works it is intended that the two existing stockpiles of soil (approximately 440,000m<sup>3</sup> in total) which are located within the SD2 Infrastructure area (refer to Figure 5.6), will be redistributed during Phase 3 to provide structural fill for the:

- Access road and internal road embankments;
- Flood protection berm; and
- Construction camp and construction areas.

It is intended to move spoil directly to the point of use where practicable to avoid double handling.

The removal of the 70 hectares of surface soil represents a loss of existing habitat<sup>20</sup>. Where the areas will be subsequently developed (e.g. the footprint of the SD2 Expansion, North Construction Camp and South Construction Facilities areas and the route of new access road) the loss will be permanent. Where use of the area is temporary (initial site compound, Enabling Road and parts of the Pipeline Landfall Area) the loss will be temporary. Reinstatement of areas for temporary use is included within the project Base Case Design.

Drainage management works to be undertaken during Phase 3 include:

- Installation of new drainage channels within the SD2 Infrastructure area (refer to Figure 5.8); and
- Wadi works including clearance of the existing western and central wadi sea outfalls (expected to include the removal of obstructions such as rocks, vegetation and silt).

It is planned to use the excavated materials as structural fill materials where possible. It is estimated that a maximum of up to 19,000m<sup>3</sup> of material will be excavated. The works are anticipated to extend across an area of less than 5 hectares.

Removal of surface soil layer and vegetation from the Pipeline Landfall Area (refer to Chapter 5 Figure 5.6) is planned to occur during Phase 4 of the works. Excavation works will be undertaken to level the area (approximately 15 hectares). It is assumed, as a worst case, that the whole area will be stripped, all existing vegetation will be removed and excavated materials will be stored on site for re-use when required. It is understood that following the preparation works and the subsequent pipeline installation works (not included within the scope of this ESIA) the area will be reinstated.

Existing controls measures associated with terrestrial and coastal ecology include:

- When off road access is required, return journeys shall be made along the same routes where practicable to minimise disturbance.
- A construction corridor will be established along the access road route and the perimeter of the corridor defined. Works within the wetland area outside this perimeter, with the exception of planned wadi clearance works, will be strictly controlled by BP in order to minimise the area of ground disturbed.
- Surface soil layer removal and vegetation clearance near to wetlands, rivers or stream banks shall be minimised.
- Prior to removal, vegetation shall be inspected to detect presence of wildlife and activities ceased until appropriate action is taken to ensure any wildlife encountered is not harmed.
- Areas for laydown of soil or loose construction materials shall be identified to minimise impact to habitats and potential for erosion and sedimentation into watercourses or drains.
- Daily checks for wildlife shall be undertaken of excavations prior to work commencing. Where practical excavations should be covered overnight.
- Records will be maintained of all landscape management works.
- A Spoil and Landscape Management Plan will be prepared and will include details of the amount of spoil generated, reused, disposed of and the contamination potential of the spoil. The Plan will also cover details of a Biorestitution Plan.
- The Biorestitution Plan will be developed and implemented to restore all areas of disturbed land used on a temporary basis during the SD2 Infrastructure works to their preconstruction condition.
- A Wildlife Management Plan will be developed and implemented to manage the relocation of any mammals, reptiles or any IUCN or Azerbaijan Red Data Book listed species encountered within the areas affected by the SD2 Infrastructure works.

Table 9.15 presents the justification for assigning a score of 8, which represents a Medium Event Magnitude.

---

<sup>20</sup> Areas that have already been disturbed e.g. the footprint of the existing stockpiles have been excluded from this total.

**Table 9.15 Event Magnitude**

Parameter	Explanation	Rating
<b>Extent/Scale</b>	It is anticipated that surface soil and vegetation will be removed from an area of approximately 85 hectares in total which comprises desert and semi desert habitat. This represents a permanent loss for the majority of the area affected. An additional 5 hectares will be affected by excavations due to drainage management works.	2
<b>Frequency</b>	Once.	1
<b>Duration</b>	The removal of the surface soil and vegetation will be permanent in the majority of locations.	3
<b>Intensity</b>	Part of the loss of habitat due to surface soil removal will be permanent (more than 50%). The remainder will be reinstated. Habitat affected is not considered to be particularly sensitive or critical.	2
Total:		<b>8</b>

**9.5.1.2 Receptor Sensitivity**

Construction activities have the potential to impact habitats and flora, fauna and breeding birds.

Local vegetation in the vicinity of the SD2 Infrastructure area (refer to Section 6.4.7.1) is characterised by floral species which are typical for the area surrounding the Terminal and are neither rare nor threatened. The main vegetation assemblages are dominated by low perennial shrubs (*Salsola nodulosa*, *Salsola dendroides*, *Suaeda dendroides*, *Salsola ericoides* and *Artemisia lerchiana*). One Azerbaijan Red Data Book listed species (*Iris acutiloba*) was recorded during surveys in 2004, 2005 and 2008. This species was found at survey locations to the north east of the Terminal (i.e. not within areas likely to be affected by the SD2 Infrastructure works).

Other than through direct disturbance as a result of ongoing activities immediately adjacent to the Terminal, monitoring has shown no significant change in the distribution or status of desert/semi-desert vegetation over time. Disturbed ground has shown a poor level of natural recovery over time with faster re-vegetation observed in areas where temporary surface water has been present after rainfall events.

The area around the locations for the wadi clearance works comprises wetland vegetation. The main wetland habitats are reedbeds, reedmace, rush dominated marshes and tamarisk/alhagi scrub (chal-meadow). The area is dynamic in nature and dependant on seasonal water flow through the wadi system in addition to smaller contributions from local sources (e.g. existing leaks from water pipelines in the 3<sup>rd</sup> party corridor as observed during the June 2011 wetland walkover - refer to Chapter 6 Section 6.4.7). Other than this seasonal change, surveys undertaken during 2002, 2010 and 2011 have not shown any significant alteration in the wetlands over time (e.g. in terms of species present and extent of wetlands), other than as a direct result of 3<sup>rd</sup> party construction activities. The habitat is not considered unique and the area affected by the works is not critical to the function of the habitat as a whole.

The coastal zone where the Pipeline Landfall Area preparation works are proposed supports desert vegetation dominated by sparse *Salsola nodulosa*, with occasional specimens of other species, including *Suaeda*, *Artemisia* and *Armeria*. The surveys undertaken show that there are no rare or threatened plant species present and the habitat is typical of that throughout the coastal zone. The area where the previous ACG/SD pipelines were installed has been rehabilitated using live plants. The results of surveys undertaken in 2007 and 2010 indicate that this effort has been successful with up to 57% vegetation cover by perennial species identified in 2010. Reinstatement associated with the SD2 Infrastructure Project will take into account lessons learnt from this earlier work.

The results of bird surveys undertaken in the Terminal vicinity are discussed in Section 9.4.1.2 above. The surveys have demonstrated that breeding birds have been identified within the Terminal vicinity. However, the habitat within the SD2 Infrastructure area is not considered critical as they have been recorded throughout the area surrounding the Terminal and use no area exclusively for feeding or nesting.

Faunal surveys have confirmed the presence of the following in the Terminal vicinity:

- Euphrates jerboa (*Allactaga euphratica*) - IUCN Lower Risk/Near Threatened.
- Grey hamster (*Cricetulus migratorius*) - IUCN Lower Risk/Near Threatened.
- Marbled polecat (*Vormela peregusna*) - AzRDBand Conservation Dependent.
- Wolf (*Canis lupus*) - no designated conservation status in Azerbaijan.
- Lizard (*Phrynocephalus helioscopus*) - no designated conservation status in Azerbaijan.
- Spur-thighed tortoise (*Testudo graeca*) - IUCN Red Data List Vulnerable and Azerbaijan Red Data Book listed.

These species have all been found in low numbers (one or two individuals on any occasion) and, with the exception of the spur-thighed tortoise, have not been recorded consistently in surveys undertaken between 2002 and 2010. While spur-thighed tortoise have been consistently recorded in the area, the precise distribution of spur-thighed tortoise has not been determined. The likely reason for the consistent records of this species is due to the relocation programme that was undertaken prior to and following the previous ACG and SD projects where spur-thighed tortoise were collected prior to the works and then reintroduced once the works were completed. The majority of suitable habitat (i.e. areas which have a mixture of scrub and short vegetation, offering both protection and food supplies) for this species lies outside the area to be affected by the SD2 Infrastructure works. The areas to be affected are not considered to be critical or particular importance. Spur-thighed tortoise are most sensitive during the breeding and egg laying periods which are between April and July.

Table 9.16 presents the justification for assigning a score of 4 for Biological/Ecological Receptor Sensitivity, which represents Medium Receptor Sensitivity.

**Table 9.16 Biological/Ecological Receptor Sensitivity**

Parameter	Explanation	Rating
<b>Presence</b>	No rare or protected plant species or breeding bird species have been recorded in the areas to be affected by the SD2 Infrastructure works during recent surveys undertaken in 2004, 2005, 2008 & 2009 (refer to Chapter 6 Table 6.1). Surveys have recorded a number of faunal species with conservation status including the spur-thighed tortoise, which is classified as vulnerable in the IUCN Red Data List, and also included within the Azerbaijan Red Data Book.	2
<b>Resilience</b>	<p><b>Habitat</b> will be lost due to surface soil removal and wadi clearance works. In areas for temporary use vegetation will be temporarily impacted. Reinstatement of these areas would lead to vegetation recovery (including the microbiotic crust) in over 20 years<sup>21</sup>. Within the pipeline landfall area, reinstatement works for the previous ACG/SD projects suggests vegetation recovery may be more rapid (3-5 years). The ecological functionality of all habitats would be maintained in the long term.</p> <p>Surveys have shown that the areas affected by the works are not critical to <b>ground nesting birds</b>, which have been recorded in the Terminal vicinity (refer to Section 9.4.1.2). The effects of the nesting areas lost would stabilise, and ecological functionality of breeding bird populations will be maintained.</p> <p>Six <b>faunal species</b> (including four with conservation status) have been recorded in low numbers in the Terminal vicinity. Direct effects are not expected assuming existing control measures are followed, however spur thighed tortoise are known to be regularly present and are particularly during the breeding season (April - July). The area affected is however not optimal and not considered critical to the existing population. The works would contribute to no more than minor temporary change. Ecological functionality of the faunal species populations will be maintained.</p>	2
		<b>4</b>

<sup>21</sup> Biological Soil Crusts: Ecology and Management, US Department of the Interior, 2001.



### 9.5.1.3 Impact Significance

Table 9.17 summarises impacts on terrestrial ecology associated with the construction works.

**Table 9.17 Impact Significance**

Event	Event Magnitude	Receptor Sensitivity	Impact Significance
Surface soil layer removal and spoil movement	Medium	Medium (Biological/ecological receptors)	<b>Moderate Negative</b>

It is considered that impacts are minimised as far as practicable and necessary through the implementation of the existing control measures as listed in Section 9.5.1.1 above and no further mitigation is required.

## 9.6 Impacts to the Terrestrial Environment (Soil, Groundwater and Surface Water)

### 9.6.1 Excavation Works and Ground Disturbance

#### 9.6.1.1 Event Magnitude

Surface soil layer removal and redistribution of spoil within existing stockpiles is discussed in Chapter 5: Project Description Sections 5.5.1, 5.5.2 and 5.5.3. The areas where surface soil layer removal will occur, the intended use of the stripped soil and the planned use of the two existing stockpiles is described in Section 9.5.1.1 above.

Drainage management works are discussed in Chapter 5: Project Description Section 5.5.3 and include the construction of new drainage channels during Phase 3. These new drainage channels comprise ditches and bunds that are lined (with concrete or geotextile) or profiled depending on their location and soil conditions and have a depth up to 1m below ground. The location of new drainage channels are shown in Figure 5.8.

While the monitoring to date (refer to Chapter 6 Section 6.4.3) has not indicated any significant or widespread contamination in the SD2 Infrastructure area, it is possible that localised areas of contaminated surface soil and spoil are present which may become mobilised by physical disturbance<sup>22</sup>.

Wadi clearance works within the wetland area to the south of the Terminal are planned to comprise clearance of the existing western and central wadi culverts to remove obstructions such as rocks, vegetation and silt. As discussed in Chapter 6 Section 6.4.4, results of the analysis from water and soil samples collected within the wetland area, including the area where the wadi clearance works are proposed, have indicated high level of Total Hydrocarbon Content (THC) and Polycyclic Aromatic Hydrocarbons (PAH) in addition to cadmium (within groundwater samples) and phenols (within soil samples). During the wetland survey undertaken in June 2011, a number of spills were identified in the wetland area (refer to Figure 6.5). All the spills appeared to be hydrocarbon; however the source was not evident.

In the event oily contaminated soil, ground water, surface water or other materials outside of the existing Sangachal Terminal property boundary are encountered and require handling:

- The soil, surface water, groundwater or other materials will be relocated to an area that is of comparable environmental quality and function;
- The relocation will be undertaken in a manner that will not degrade the environment further and will promote the natural degradation of contaminants; and

<sup>22</sup> Contaminative status of SD2 Infrastructure Area will be further defined following completion of ongoing geotechnical assessment – refer to Chapter 6 Section 6.2.

- The following details will be recorded; contaminants detected, handling methods adopted to prevent further environmental degradation, location and quantity of contaminated material detected.

Oily contaminated soil, ground water, surface water or other materials are not anticipated within the existing Sangachal Terminal property boundary. However, if encountered, contaminated materials within the existing Sangachal Terminal property boundary will be classified and managed as waste in accordance with existing BP waste management procedures.

Other controls associated with minimising mobilisation of contamination during earth works include:

- Vehicle wash facilities shall be located at least 10m from permanent water features.
- Spoil heaps shall not be stockpiled close to surface water.
- Stockpiles will be appropriately shaped and compacted to avoid erosion and sedimentation of nearby open water courses or drains.
- A transfer note system shall be used to control the movement of spoil across the site. This shall include the point of excavation, destination and waste classification.
- Site drainage and pollution hazards maps shall be maintained that show potential sources of pollution (e.g. storage areas), pathways (e.g. drains) and receptors (e.g. the Caspian Sea).
- Designated areas will be established away from watercourses for waste cement/concrete, which will be contained and collected as a waste once solidified.

Table 9.18 presents the justification for assigning a score of 6 to earthworks which represents a Medium Event Magnitude.

**Table 9.18 Event Magnitude**

Parameter	Explanation	Rating
Extent/Scale	It is anticipated that areas of contamination within the SD2 Infrastructure area will be limited. Within the wetland area there are known areas of contamination however good construction management will be adopted to minimise the potential for mobilisation of contamination.	1
Frequency	Once.	1
Duration	Earthworks will take place over the whole construction period.	3
Intensity	Good construction management is expected to minimise potential for mobilisation.	1
		<b>6</b>

### 9.6.1.2 Receptor Sensitivity

Relevant receptors include soil and surface water in the vicinity of the SD2 Infrastructure area and the areas where wadi clearance works are planned. Monitoring undertaken to date (Chapter 6 Section 6.4.4) has confirmed there is no groundwater bearing unit within 20m of the surface.

As reported within Chapter 6, recent soil quality survey results in and adjacent to the SD2 Infrastructure area (during 2006 and 2008) indicate no significant contamination. Analysis of soil samples have shown no significant exceedances of relevant standards or limit values (with the exception of elevated levels of arsenic and iron, which is considered to be naturally occurring).

Elevated levels of TPH and heavy metals were detected in surface water samples (taken in locations to the south of the Terminal). These were considered to be due to previous Soviet era hydrocarbon exploration activity.

Within the wetland area where the wadi clearance works are planned, high levels of contamination have been recorded in surface water and soil samples taken and hydrocarbon spills have been observed.

Tables 9.19 and 9.20 present the justification for assigning a score of 3 to soil and 4 to surface water which represents Medium Sensitivity.

**Table 9.19 Receptor Sensitivity (Soil)**

Parameter	Explanation	Rating
<b>Presence</b>	Affected area has moderate value as it is used for local grazing	2
<b>Resilience</b>	Soil quality is expected to be largely unaffected by earthworks. No significant existing contamination present within the SD2 Infrastructure area. Within the wetlands, high levels of contamination are present however the planned clearance works are not expected to result in significant mobilisation of contamination.	1
<b>Total</b>		<b>3</b>

**Table 9.20 Receptor Sensitivity (Surface Water)**

Parameter	Explanation	Rating
<b>Presence</b>	Surface water bodies not used for public water supply. Used seasonally by herders for watering animals.	2
<b>Resilience</b>	Water quality is expected to be largely unaffected by earthworks. Moderate to high levels of existing contamination currently present within the wetland area.	2
<b>Total</b>		<b>4</b>

### 9.6.1.3 Impact Significance

Table 9.21 summarises the impact on soil and surface water from the SD2 Infrastructure works.

**Table 9.21 Impact Significance**

Event	Event Magnitude	Receptor Sensitivity	Impact Significance
Excavation works and ground disturbance	Medium	(Soil) Medium	<b>Moderate Negative</b>
		(Surface Water) Medium	

It is considered that impacts are minimised as far as practicable and necessary through the implementation of the existing control measures as listed in Section 9.6.1.1 above and no additional mitigation is required.

## 9.7 Impacts to the Terrestrial & Coastal Environment (Cultural Heritage)

### 9.7.1 Impacts to Cultural Heritage Due to Earthworks and Piling

#### 9.7.1.1 Event Magnitude

##### Earthworks

The removal of the surface soil layer and redistribution of spoil within existing stockpiles is discussed in Chapter 5: Project Description Sections 5.5.1, 5.5.2 and 5.5.3. The surface soil layer will be removed from a depth of 0.15m at the following locations:

- Initial site Compound established in Phase 1;
- Route of the Enabling Road in Phase 2;
- SD2 Expansion Area in Phase 3;
- North Construction Camp area in Phase 3; and
- South Construction Facilities area in Phase 3.

Material within the two existing stockpiles of spoil (Figure 5.6) will also be removed and redistributed during Phase 3 clearance works to provide structural fill. The Pipeline Landfall Area will be stripped and levelled.

While a non-intrusive archaeological survey, undertaken in 2001, in the Terminal vicinity identified one find within the SD2 Infrastructure area, a subsequent walkover in 2011 indicated that the likelihood of encountering extensive settlement remains in this area appears to be relatively low. There is potential, however, that the physical removal of the upper layer of surface soil and movement of spoil may impact cultural heritage resources if present. The areas beneath the existing spoil heaps are likely to be substantially impacted as a result of past activity in the area. Nearly 75% of the Pipeline Landfall Area was disturbed previously by aggregate or limestone quarrying. It is considered that there is no potential for archaeological remains in the area disturbed by previous quarrying.

Drainage management works are planned to include the construction of new drainage channels and wadi clearance works in the vicinity of the Western and Central drainage channel outfalls (refer to Chapter 5 Figure 5.8). The new drainage channels are planned within the SD2 Infrastructure area whereas the wadi clearance works will include subsurface groundworks in the vicinity of engineering features north and east of the Caravanserai (a State protected monument to the south of the Terminal – refer to Chapter 6 Section 6.6).

Existing controls associated with cultural heritage include:

- A watching brief shall be maintained to identify any artefacts of archaeological importance and a chance finds procedure shall be in place.
- Any findings will be reported immediately and any corrective measures required will be agreed with an archaeological specialist in liaison with the Ministry of Culture and Tourism and the Institute of Archaeology and Ethnography.
- In the event archaeological resources are found during excavation work an assessment will be made by the archaeological watching brief on what controls and changes to the excavation work are required and whether work in the area needs to be suspended to allow for a more detailed archaeological assessment of the area.

Within the draft SD2 Infrastructure Project ESIA it was reported that cultural heritage baseline surveys were planned in liaison with the MoCT and IoAE to supplement the earlier 2011 walkover survey to comprise:

- A comprehensive archaeological walkover of the areas affected by the SD2 Infrastructure area; and
- A photo survey and mapping of the Caravanserai to confirm condition and extent.

These surveys have been completed by URS and the Azerbaijan Institute of Archaeology and Ethnography (IoAE) in 4Q 2011. The results of the survey are pending and will inform the Archaeology and Cultural Heritage Management Plan (refer to Chapter 12 Table 12.1). In general it is understood that no significant archaeological finds were encountered and the structural condition of the Caravanserai was considered to be good.

## **Piling**

Piling activities are planned to include driven pile trials in the SD2 Expansion Area and bored piles at the pipeline crossings (refer to Section 9.5.1.1 above). Piling activities, especially driven piles, can generate vibrations within soil and rock matrices that have the potential to impact cultural heritage structures, such as the Caravanserai. The driven piles trials are planned to be located west of the SD2 Expansion Area more than 1km from the

Caravanserai. The areas where the bored pipeline crossings are planned are located a minimum of 250m from the Caravanserai. As vibrations from piling activities are not expected to travel more than 50m from the source it is considered unlikely that the Caravanserai would be affected by piling activities.

Table 9.22 presents the justification for assigning a score of 6 to earthworks and piling activities which represents a Medium Event Magnitude.

**Table 9.22 Event Magnitude**

Parameter	Explanation	Rating
<b>Extent/Scale</b>	<p><b>Surface soil removal</b> - The extent of surface soil to be removed is relatively shallow (0.15m) but will cover a broad area. Although significant archaeological features are not expected to be present within this upper layer of surface soil, or under existing stockpiles of spoil, limited impacts are possible.</p> <p><b>New drainage channels</b> - The extent of material to be removed for construction of new drainage channels represents a small area, but one that transects much the SD2 Infrastructure area.</p> <p><b>Wadi clearance works</b> - The extent of material to be removed for the wadi clearance groundworks represents a small area, however the works are located less than 500m from the Caravanserai, which is a State protected monument.</p> <p><b>Piling</b> - The piling activities are of limited extent but are located less than 500m from the Caravanserai.</p>	2
<b>Frequency</b>	Damage to cultural heritage sites are not expected to occur because the planned archaeological baseline survey is expected to identify those sites greater than 0.5 hectares in extent.	2
<b>Duration</b>	Damage to cultural heritage sites is not expected to be of long duration because watching brief will prevent substantive damage.	1
<b>Intensity</b>	Low intensity event as no damage to cultural heritage is expected to occur.	1
		<b>6</b>

**9.7.1.2 Receptor Sensitivity**

Table 9.23 presents the justification for assigning a score of 4 to cultural heritage which represents Medium Sensitivity.

**Table 9.23 Receptor Sensitivity**

Parameter	Explanation	Rating
<b>Presence</b>	There are no State protected monuments or other cultural heritage sites known to occur within the SD2 Infrastructure Area. However wadi clearance works and piling works are planned within 500m of the Caravanserai.	3
<b>Resilience</b>	It is anticipated that the status of cultural heritage will be unaffected by the proposed work.	1
<b>Total</b>		<b>4</b>

**9.7.1.3 Impact Significance**

Table 9.24 summarises impacts on cultural heritage from earthworks and piling.

**Table 9.24 Impact Significance**

Event	Event Magnitude	Receptor Sensitivity	Impact Significance
Impact to cultural heritage from earthworks and piling	Medium	Medium	<b>Moderate Negative</b>

It is considered that impacts are minimised as far as practicable and necessary through the implementation of the existing control measures (which includes the use of a watching brief and a chance finds procedure) and no additional mitigation will be warranted.

## 9.8 Summary of SD2 Infrastructure Project Residual Environmental Impacts

For all environmental impacts assessed it has been concluded that impacts are minimised as far as practicable and necessary through the implementation of the existing control measures and the development and implementation of an environmental social management system during the construction works (refer to Chapter 12 for further details).

Table 9.25 summarises the residual environmental impacts.

**Table 9.25 Summary of SD2 Infrastructure Project Residual Environmental Impacts**

	Event	Event Magnitude	Receptor Sensitivity	Impact Significance
Atmosphere	Emissions from onsite and offsite construction plant and vehicles.	Medium	(Humans) Medium	<b>Moderate Negative</b>
	Emissions from surface soil layer removal and spoil movement.			
Noise	Noise emissions associated with construction activities.	Medium	(Humans) Medium (Biological/ Ecological) Medium	<b>Moderate Negative</b>
Impact to the Terrestrial and Coastal Environment (Ecology)	Surface soil layer removal and spoil movement, drainage management works and Pipeline Landfall Area preparation.	Medium	(Biological/ Ecological) Medium	<b>Moderate Negative</b>
Impact to the Terrestrial Environment (Soil, Groundwater and Surface Water)	Excavation works and ground disturbance.	Medium	(Soil) Medium	<b>Moderate Negative</b>
			(Surface Water) Medium	<b>Moderate Negative</b>
Impact to the Terrestrial and Coastal Environment (Cultural Heritage)	Impacts to cultural heritage due to earthworks and piling.	Medium	(Physical Resource) Medium	<b>Moderate Negative</b>

## 10. Socio-Economic Impact Assessment, Mitigation and Monitoring

### Contents

10.1	Introduction.....	2
10.2	Scoping Assessment.....	2
10.3	Land Access.....	4
	10.3.1 Disruptions / Access Restrictions to Natural Resources and Recreation .....	4
10.4	Employment.....	7
10.5	Training and Skills Development.....	8
10.6	Procurement.....	10
10.7	Construction Vehicle Movements (offsite).....	11
	10.7.1 Disruption and Community Safety.....	11
	10.7.2 Road Conditions.....	12
10.8	Road and Rail Works .....	13
10.9	De-manning.....	14
10.10	Indirect Impacts .....	15
	10.10.1 Local Economic Impacts .....	15
	10.10.2 Social Conflict.....	16
	10.10.3 Anti-Social Behaviour .....	16
	10.10.4 Mitigation of Indirect Impacts.....	16
10.11	Summary of SD2 Infrastructure Project Residual Socio-Economic Impacts .....	16

### List of Tables

Table 10.1	“Scoped Out” SD2 Infrastructure Project Routine and Non-Routine Activities .....	3
Table 10.2	“Assessed” SD2 Infrastructure Project Routine and Non-routine Activities .....	4
Table 10.3	Socio Economic Impact Significance for Disruption/Access Restrictions to Natural Resources and Recreation.....	6
Table 10.4	Socio Economic Impact Significance for Employment Creation .....	8
Table 10.5	Socio Economic Impact Significance for Training and Skills Development .....	9
Table 10.6	Socio Economic Impact Significance for Procurement of Goods and Services ...	10
Table 10.7	Socio Economic Impact Significance for Construction Vehicle Movements (offsite) .....	12
Table 10.8	Socio Economic Impact Significance for Road Condition.....	13
Table 10.9	Socio Economic Impact Significance for Road and Railway Closures and Traffic Works .....	14
Table 10.10	Socio Economic Impact Significance for De-manning .....	15
Table 10.11	Summary of SD2 Infrastructure Project Residual Socio-Economic Impacts .....	17



## **10.1 Introduction**

This Chapter describes the socio-economic impacts, and mitigation and monitoring measures, associated with the SD2 Infrastructure Project.

In accordance with the impact assessment methodology (see Chapter 3), ESIA Scoping was undertaken to identify selected Activities and associated Events that might impact the socio-economic environment or, alternatively, that might be excluded from the full socio-economic impact assessment process. The scoping assessment determined impact significance by considering the expected likelihood of impacts, magnitude of events, nature of interactions and the sensitivity of socio-economic receptors against existing controls and mitigation measures. This Chapter sets out the requirements for monitoring to confirm that those controls and mitigation measures are implemented and effective.

## **10.2 Scoping Assessment**

The scoping process has used judgement based on prior experience of similar Activities and Events, especially with respect to earlier ACG and SD construction activities at the Terminal. In some instances, scoping level quantification/numerical analysis has been used to justify the decision. Reference is made to relevant quantification, analysis, surveys and/or monitoring reports in these instances.

The scoping process excluded a number of SD2 Infrastructure Project Activities and associated Events due to their limited potential to result in discernable socio-economic impacts, or if they were already covered in other Chapters of the ESIA. The activities and associated events excluded from the socio-economic impact assessment are presented in Table 10.1 (see Appendix 10A for all SD2 Infrastructure Project Activities, Events and Interactions).

**Table 10.1 “Scoped Out” SD2 Infrastructure Project Routine and Non-Routine Activities**

ID	Activity / Event	Ch. 5 Project Description Reference	Justification for “Scoping Out”
S1-R	Land Acquisition	5.2	<ul style="list-style-type: none"> <li>• It will be necessary to acquire up to 302 hectares of land in the immediate vicinity of the Terminal.</li> <li>• It is understood that this land is currently owned by the State Government and there is no existing income to the Government from this land.</li> <li>• The area of land to be acquired is small in a regional and national context of land ownership.</li> </ul> <p><b>Conclusion:</b> Very limited potential for impact from land acquisition.</p>
S6-R	Operation of construction plant and vehicles onsite and offsite, movement of spoil, subsurface and above ground structural works and erection of buildings/structures - Community Disturbance (e.g. noise, dust).	N/A	<ul style="list-style-type: none"> <li>• Community disturbance impacts assessed within Chapter 9.</li> </ul>
S9-R	Connections to mains water supply - Disruption to freshwater supply.	5.5.4	<ul style="list-style-type: none"> <li>• Mains water supply connections planned during Phase 4.</li> <li>• Connection to mains water supply to be managed in liaison with utility owner.</li> <li>• Utility owner required to manage any potential disruptions to community.</li> </ul> <p><b>Conclusion:</b> Potential disruption to local community associated with water supply connections to be managed by utility owner. No discernable impact anticipated.</p>
S10-R	Connections to mains power supply- Disruption to freshwater supply.	5.5.2	<ul style="list-style-type: none"> <li>• Power at initial site compound, temporary security compound, Pipeline Landfall Area and at construction camp/facilities prior to tie in to be provided by diesel generators.</li> <li>• Diversion of power lines in the vicinity of the SD2 Infrastructure Area and mains power supply connections planned during Phase 2.</li> <li>• Connection to mains power supply and power line diversions to be managed by utility owner.</li> <li>• Utility owner required to manage any potential disruptions to community.</li> </ul> <p><b>Conclusion:</b> Potential disruption to local community associated with power supply connections to be managed by utility owner. No discernable impact anticipated.</p>
S11-R S12-R S13-R S14-R	In-migration of workers resulting in increased pressure on community infrastructure (utilities, waste & sewage, goods & services, employment and health services).	N/A	<ul style="list-style-type: none"> <li>• It is anticipated that the workforce will comprise between 450 and 700 persons.</li> <li>• It is expected that the majority of workers will be resourced from the vicinity of the Terminal. Local targets (for professionals and non professionals) will be determined to maximise employment as far as practical for the existing residents of Sangachal Town, Umid, Azim Kend or Masiv 3, which will be verified by the prospective employee's identification card.</li> <li>• Workers will be transported to and from site daily. No workers will be resident at the construction site.</li> <li>• In migration of workers expected to be very low and consequently there is little potential for impacts to occur to community utilities, waste and sewage facilities, local goods and services and employment from in influx of non resident workers.</li> <li>• A Community Health Plan will be developed and implemented to address and monitor community health risks associated with the infrastructure construction work.</li> </ul> <p><b>Conclusion:</b> Very limited potential for impacts to community utilities, waste and sewage facilities, local goods and services, employment and health services due to in migration of non resident workers during SD2 Infrastructure Project.</p>

The SD2 Infrastructure Project routine and non-routine Activities and associated Events included in the scope of the socio-economic impact assessment are presented in Table 10.2.

**Table 10.2 “Assessed” SD2 Infrastructure Project Routine and Non-routine Activities**

ID	Activity	Phases	Ch. 5 Project Description Reference	Event	Event Category
S2-R	Disruption/access restrictions to natural resources and recreation	Phases 2-6	5.5.2-5.5.6	Disruption/access restrictions to grazing land around terminal.	Land Use and Access
				Disruption/access restrictions to wetland area.	
				Disruption/access restrictions to fishing areas.	
S3-R	Employment creation	All Phases	5.9	Job creation.	Employment
S4-R	Training and skills development	All Phases	5.9	Workforce training and skills development.	Training and Skills Development
S5-R	Procurement of goods and services	All Phases	5.3	Increased economic flows.	Procurement
S7-R	Construction vehicle movements (offsite)	N/A	N/A	Disruption to road users and community safety.	Road and Rail
				Deterioration of public roads/highway.	
S8-R	Road/rail works	Phases 2-7	5.5.2-5.5.7	Disruption to road users.	
				Disruption to railway users.	
S15-R	De-manning	Phase 7	5.9	Loss of jobs.	De-manning

## 10.3 Land Access

### 10.3.1 Disruptions / Access Restrictions to Natural Resources and Recreation

The project activities from the establishment of the initial site compound during Phase 1 (Chapter 5 Section 5.5.1) to the closure of the EOP Road and the At-Grade Railway Crossing during Phase 7 (Chapter 5 Section 5.5.7) will all involve disruption to the land within the footprint of the SD2 Infrastructure area. This includes the Pipeline Landfall Area and temporary and permanent access restrictions to natural resources and recreational areas.

It will be necessary to fence each area temporarily during the construction works for safety and security reasons. It is likely that the Pipeline Landfall Area will remain fenced following the preparation works for security reasons. In addition, while the access road crossings incorporate sufficient space for herders to cross underneath during construction works, the area around the access road during these works will be temporarily unavailable.

#### *Probability*

The change in land access may impact:

- **Local herders** - economic displacement may be experienced due to an increase in the travel time required to reach favoured grazing areas, and a reduction in the total amount of land accessible for grazing;
- **Recreational fishermen** – fishing from the shoreline area in front of the Terminal is understood to be for recreational purposes (refer to Chapter 7 Section 7.4.6);
- **Commercial fishermen** – fishing may be impacted by restricted access to the Pipeline Landfall Area;
- **Recreational users** – potential impact to those who use the beach area for recreation use e.g. walking; and
- **Shoreline properties (under construction)** (refer to Chapter 7 Section 7.4.2) – there is the potential for property values to be reduced from increased industrialisation of the area.

The probability for impacts to occur depends upon the receptor. It is considered 'highly likely' that impacts to herders, fishermen (recreational and commercial) and recreational users will occur as the temporary or permanent access restrictions and disruption to land associated with the project will occur in, or immediately adjacent to, areas used by these groups at present.

Impacts to the value of partially constructed shoreline properties are considered to be 'unlikely'. The properties are yet to be fully completed and it is understood their likely use is as occasional homes (e.g. summer homes). They are located immediately to the south of the Terminal with the Highway to the north and their location is not considered sensitive to change. No change to access is expected as a consequence of the project.

### *Magnitude*

The magnitude of the expected impacts is evaluated as follows:

- **Local herders** – As stated within Chapter 7 Section 7.4.6, herding of cattle, goats and sheep is undertaken in the area surrounding the Terminal. There are two herder settlements located to the east of the Terminal (refer to Figure 7.2). Herders from these settlements are known to use the land in the Terminal vicinity particularly during the winter months. It is understood that herding activities associated with the local communities is undertaken throughout the year. There is a partial fence located to the west of the Terminal, however this does not provide full exclusion to this area or completely restrict access into the SD2 Expansion Area. It is anticipated that for the duration of the project the majority of the land associated with the SD2 Infrastructure area (including the Pipeline Landfall Area) will be inaccessible to herders as temporary fencing is erected to prevent unauthorised access to the construction areas. Following the project completion the developed areas associated with the project (e.g. SD2 Expansion Area, Construction Camp, Construction Facilities and the route of the new access road) will no longer be available for herding. This equates to approximately 115 hectares. No permanent fencing is proposed as part of the works.
- **Recreational and commercial fishermen** – As stated within Chapter 7 Section 7.4.6 recreational and commercial fishing is undertaken to the east of the Pipeline Landfall Area and generally occurs during the summer months. It is anticipated that the preparation works associated with the Pipeline Landfall Area will be undertaken during Phase 4 (i.e. between March 2012 and June 2013 - refer to Chapter 5 Section 5.4). It is therefore anticipated that works within the Pipeline Landfall Area may impact these activities during the summer months only. The Pipeline Landfall Area however is not known to be used for fishing and therefore the impact would be limited to indirect impacts e.g. potential disruption. It is understood, from informal discussions with local fishermen, that there are a number of individuals undertaking recreational fishing and approximately 20-30 individuals are involved in commercial fishing. None of the 200 household surveyed by the SSES undertake fishing activities.
- **Recreational users** – The shoreline area is known to be used on an occasional basis as a local amenity. Potential impacts to access will occur following the erection of temporary fencing around the Pipeline Landfall Area.
- **Shoreline properties (under construction)** - A total of 7 properties are in various stages of construction north east of the Pipeline Landfall Area (refer to Chapter 7 Section 7.4.2) and will not be directly impacted by the shoreline works. It is not anticipated that there will be any change to access to these properties. The properties closest to the Pipeline Landfall Area are enclosed within a high wall and access is provided via a dedicated road.

### Receptor Sensitivity

Receptor sensitivity is evaluated as:

- **Local herders** – considered to be ‘high’ as livestock is anticipated to be an important source of primary and secondary household income;
- **Recreational fishermen** – considered to be ‘low’ as fishermen do not rely on catch from recreational fishing activities as a source of primary or secondary income, and will be able to seek out alternative fishing grounds for informal use as they are mobile;
- **Commercial fishermen** – considered to be ‘medium’ as while it is understood that fishing along the shoreline constitutes a primary source of household income, the areas where commercial fishing is known to occur is to the east of the Pipeline Landfall Area. No direct impacts are expected;
- **Recreational users** – considered to be ‘low’ as users will not experience a reduction in household income, and can easily seek out alternative areas for recreational use; and
- **Shoreline properties (under construction)** – considered to be ‘low’ as access to the partially-constructed buildings is not expected to be directly impacted.

Table 10.3 presents the justification for assigning moderate-major impact significance to disruption and access restrictions to natural resources and recreation associated with local herders and negligible significance to recreational fishermen, recreational users of the shoreline and value of shoreline properties and negative significance to commercial fishermen.

**Table 10.3 Socio Economic Impact Significance for Disruption/Access Restrictions to Natural Resources and Recreation**

Event	Magnitude		Probability	Receptor Sensitivity	Significance
	Spatial Scope	Timing and Duration			
Disruption and access restrictions (SD2 Infrastructure Area)	Local	All SD2 Infrastructure area will be temporarily fenced during works to prevent unauthorised access.	Highly likely	Local herders – High	<b>Moderate – major negative</b>
		Temporary			
		Up to approximately 115 hectares will be permanently removed from use for herders.			
Disruption and access restrictions (Pipeline Landfall Area)	Local	The majority of the SD2 Infrastructure Area will be temporarily fenced during works (between March 2012 and June 2013).	Highly likely	Recreational fishermen - Low	<b>Negligible</b>
			Highly likely	Commercial fishermen - Medium	<b>Negative</b>
			Highly likely	Recreational users - Low	<b>Negligible</b>
			Unlikely	Shoreline property values - Low	<b>Negligible</b>
		Temporary			

It is considered that impacts to recreational fishermen, recreational users and the value of the shoreline properties are minimised as far as practicable and necessary. No additional mitigation is required.

## 10.4 Employment

It is anticipated that the project will employ between 450 and 700 people over the duration of the works (Chapter 5 Section 5.9).

The construction contractor will be required to implement a Workforce Welfare and Local Employment Plan which aims to maximise the employment opportunities for local people (refer to Chapter 12 for full details).

The existing controls associated with employment to the local communities are:

- Information will be provided to local communities by the construction contractor undertaking the work on the nature and levels of employment required;
- At all times the individual recruited will be the person who is most suited to the particular post, based on the applicant's abilities, qualification, experience and merit as measured against the job description and person specification;
- Measures will be implemented to maximise employment as far as practical from residents of local communities in the vicinity of Sangachal Terminal, to achieve, or improve if practical, the local content percentages achieved for the previous ACG and SD construction projects;
- Where local employment (professionals and non professionals) falls below the specified target, the reasons for this non-compliance will be investigated and practical measures developed and undertaken to meet the targets;
- A grievance procedure for managing all community complaints related to the recruitment process will be established; and
- The process and outcomes of all recruitment, including the number of applications, numbers accepted for interview and numbers offered employment, will be monitored and recorded. A record will also be made of the level of employment from local communities and employment from outside of this local area.

The construction contractor will be required to report records of applications received, interviews held and jobs offered. The numbers of people who apply and are employed from the local communities, will be recorded. All employment-related grievances, including those associated with recruitment processes, will be recorded and reported, along with details of measures taken to resolve the concerns raised.

### *Probability*

Employment within the local communities is considered 'highly likely'. The benefits of employment to individuals are expected to include a rise in their socio-economic status, increased household expenditure particularly on education and healthcare and, also, their general well-being. Workers from households in Azim Kend and Masiv 3 are likely to experience the greatest positive change in socio-economic status, due to their current low levels of expenditure on education and healthcare when compared with households in Sangachal and Umid (refer to Chapter 7 Section 7.4.8).

Employment creation may benefit a greater number of individuals than the total workforce, as the increased household income will likely benefit relatives, partners and children.

On a regional level, it is expected that employment is considered 'likely', specifically as workers may be recruited from the wider region to fill specific roles that cannot be resourced from the local area.

### *Magnitude*

The total number of people employed is expected to increase to a maximum of 700. It is reasonable to assume that this will likely coincide with the greatest period of activity on site (i.e. the period when most phases overlap). This is anticipated to be between April 2012 and November 2012.

### Receptor Sensitivity

As reported within Chapter 7 Section 7.4.6 in September 2008, 400 people in the Garadagh region were registered as unemployed. Within the households surveyed during the June 2011 Stakeholder and Socio-Economic Survey (SSES), 66% respondents considered themselves to be unemployed. It is therefore considered that there is a strong demand for employment in the local communities.

On the basis on the reported high level of unemployment in the local communities and the expectation that BP and its contractors will provide preferential employment to local people during the project (as reported within the community focus groups conducted as part of the SSES), the sensitivity of the local communities is considered 'High'.

The sensitivity of the wider region, where the expectation for jobs associated with the project is lower, is considered to be 'Medium'.

Table 10.4 presents justification for assigning a Moderate-Major Positive impact significance to employment creation at a local level, and a Positive impact at a regional level.

**Table 10.4 Socio Economic Impact Significance for Employment Creation**

Event	Magnitude		Probability	Receptor Sensitivity	Significance
	Spatial Scope	Timing and Duration			
Employment creation	Local	Employment will occur throughout the project, and is expected to peak between April 2012 and November 2012	Highly likely	Local community - High	<b>Moderate-Major Positive</b>
	Regional	Temporary impact	Likely	Regional community – Medium	<b>Positive</b>

It is considered that local and regional impacts associated with employment are maximised as far as practicable through the existing controls listed above. No additional measures are required.

## 10.5 Training and Skills Development

Training and Employment is discussed in Chapter 5 Section 5.9.

The existing controls associated with training and skills development are:

- The construction contractor will be required to put a Training Plan in place which describes training programmes that are expected to be similar in content to those implemented for previous ACG and SD projects (refer to Chapter 7 Section 7.4.6.1). The aim of the Training Plan will to provide training and skill development opportunities, with a particular emphasis on the training of Azerbaijani citizens;
- A formal system of competency assurance will be implemented and records maintained of competency testing and training activities completed;
- A self-verification system will be implemented to monitor performance of all training and competency assessment activities against the Training Plan, with any deficiencies rectified through appropriate actions;
- Where required by Azerbaijani law, approval from the appropriate authority will be obtained for training courses and trainers;
- The training and competency plans will be monitored through regular audits, which aim to determine the effectiveness of the Training Plan. Any changes to the Training Plan will be approved; and
- Recognition will be given to the diversity of language used by workers. Supervision will be assisted by suitably qualified and experienced interpreter who will speak



English and the native languages of the workforce. Tool-box talks will be translated into the native languages of the workforce to aid communications.

*Probability*

It is considered 'highly likely' that workers from both the local and regional area will undertake training and skills development activities, and will benefit from the programmes provided. It is also considered likely that income gained through employment may also be used to fund external training and other skills development activities, either during or following completion of their employment

*Magnitude*

Training and skills development will occur prior to the commencement of project activities as workers will be required to undergo training to undertake the works to the required standard. As in the case of the previous ACG and SD projects, training is expected to encompass technical skills in addition to Health and Safety, information technology and administration skills. Training and skills development is expected to be ongoing throughout the project, and will provide workers with skills that can be used to obtain alternative employment in future roles.

*Receptor Sensitivity*

Receptor sensitivity to training and skills development is 'high' as there is a strong expectation among the local communities that training and skills development activities will be provided. This is, in part, as a result of the previous training provided for ACG and SD projects. Sensitivity in the regional area is expected to be 'medium' due to this expectation.

Table 10.5 presents the justification for assigning Moderate-Major positive significance and Positive significance to training and skills development for local and regional workers respectively.

**Table 10.5 Socio Economic Impact Significance for Training and Skills Development**

Event	Magnitude		Probability	Receptor Sensitivity	Significance
	Spatial Scope	Timing and Duration			
Training and skills development	Local	Training will commence prior to the project activities and continue throughout the project. Permanent	Highly likely	Local community – High	<b>Moderate-Major positive</b>
	Regional		Highly likely	Local community – Medium	<b>Positive</b>

It is considered that local and regional impacts associated with training and skills development are maximised as far as practicable through the existing controls listed above. No additional mitigation is required.

## 10.6 Procurement

As stated within Chapter 5 Section 5.3, preference will be given to source equipment (such as plant and construction vehicles) and materials (such as gravel) which meet the required project specifications from Azerbaijan wherever possible.

### *Probability*

It is anticipated that the procurement of materials, equipment, goods and services from local, regional and national businesses is 'highly likely' and these businesses will experience an associated increase in their turnover as a result. As a minimum, this is expected to benefit business owners and existing staff if their current levels of remuneration are increased.

### *Magnitude*

The procurement of materials, equipment, goods and services will commence prior to the commencement of project activities and will continue throughout the project. The anticipated benefit to businesses cannot be quantified with confidence at present as the procurement strategy and award of construction contracts has been not been made. It is however, assumed the aggregate materials (if suitable for project use) will likely be available locally given the location of a number of quarries within 30km of the Terminal. In addition given the substantial number of construction projects within and near to Baku and in the wider area, it is expected that construction plant and vehicles are likely to be available in country. It is not currently known whether the construction plant and vehicles available meets project specifications.

### *Receptor Sensitivity*

It is considered that receptor sensitivity is 'high' on the basis that:

- There is a strong expectation amongst local, regional and national business owners that a significant proportion of the total procurement will be allocated to in-country suppliers; and
- The use of local, regional and national businesses to supply goods and materials will contribute towards socio-economic development.

At a national level, receptor sensitivity is considered to be 'Medium' given the lower awareness and expectations associated with the project.

Table 10.6 presents the justification for assigning a Moderate-Major positive significance to the procurement of goods and services at a local and regional level; and Positive Significance at a national level.

**Table 10.6 Socio Economic Impact Significance for Procurement of Goods and Services**

Event	Magnitude		Probability	Receptor Sensitivity	Significance
	Spatial Scope	Timing and Duration			
Procurement of goods and services	Local, and Regional	Procurement will take place throughout the project and benefits will cease shortly after the project finishes  Temporary	Highly likely	Local and regional businesses - High	<b>Moderate-Major positive</b>
	National			National businesses - High	<b>Positive</b>

It is considered that local, regional and national impacts associated with the procurement of goods and services are maximised as far as practicable and no additional measures are

required. In line with the procedures of previous projects (Chapter 7 Section 7.6) records to monitor national spend will be kept of all goods and services purchased in-country, including the value of spend.

## **10.7 Construction Vehicle Movements (offsite)**

### **10.7.1 Disruption and Community Safety**

The estimated number of construction vehicle movements (offsite) is discussed in Chapter 5 Section 5.7.2. The contribution of daily vehicle movements to existing traffic flows on the Baku-Salyan Highway is expected to peak at 162 (between May 2012 and October 2012). As stated within Chapter 5, traffic associated with the project will initially use the existing Terminal access road (during Phase 1). The EOP road and an associated junction on the northern side of the Highway will then be used as the main access route for SD2 Infrastructure Project construction traffic until the new Highway Junction is completed by the Highways Authority.

The existing controls associated with construction vehicle movements (offsite) are:

- All received grievances associated with traffic will be logged and appropriate corrective action determined which will be recorded in the Transportation and Traffic Management Plan. The focus of the Plan will be on ensuring that drivers and their vehicles are safe when on the road and adopt safe driving behaviours. The Plan will include a requirement to adhere to strict driver management standards which will be strictly enforced, and describe the procedures adopted when transporting abnormal loads;
- Off-road driving outside of designated areas will be prohibited; and
- Prior to the transportation of oversized and heavy loads, a risk assessment will be undertaken to include an inspection of the transport route for obstructions and hazards, any requirement for traffic diversion and lifting, loading and rigging. The Azerbaijan Ministry of Transport and the police will be notified prior to the scheduled movement. Once approved for movement, oversized and heavy loads will be accompanied by front and back escort vehicles equipped with appropriate warning signage and/or lights.

#### *Probability*

The expected probability of disruption and impact to community safety associated with project related traffic is considered 'unlikely' based on measures incorporated within the Transportation and Traffic Management Plan.

#### *Magnitude*

Construction vehicle movements (offsite) will commence in Phase 1 and will continue throughout the project. The maximum daily project-related contribution to traffic will peak at 162 vehicles per day. This represents a total traffic flow increase of approximately 1.62%.

#### *Receptor Sensitivity*

Receptor sensitivity is considered to be 'high' as the daily movement of construction vehicles (offsite) will pass close to and through local communities where there is increased potential for impacts to community safety.

Table 10.7 presents the justification for assigning negative significance to Construction Vehicle Movements (offsite).

**Table 10.7 Socio Economic Impact Significance for Construction Vehicle Movements (offsite)**

Event	Magnitude		Probability	Receptor Sensitivity	Significance
	Spatial Scope	Timing and Duration			
Disruption and impact to community safety associated with construction vehicle movements (offsite)	Local	Offsite traffic movements will take place throughout the project.  Temporary	Unlikely	Road users and local community – High	<b>Negative</b>

To further minimise the potential impact associated with offsite traffic movements to the local communities, it will be necessary to communicate the potential hazards associated with offsite traffic movements, as part of ongoing community liaison.

It is considered that impacts to the local communities associated with offsite construction vehicle movements are minimised as far as practicable. No additional mitigation is necessary.

### 10.7.2 Road Conditions

It is expected that the Baku-Salyan Highway will be the primary route that is used for the transport of construction materials. However, the exact transport routes used will not be determined until the procurement strategy is in place and the construction contract has been awarded.

The existing controls associated with road conditions are:

- Prior to construction works commencing, a survey to determine the condition of public roads used will be undertaken to investigate the suitability of roads and identify any improvements required; and
- Following the completion of construction works, the condition of the public roads used will be resurveyed. If results indicate that road damage occurred during the construction works then the road will be restored to its pre-construction state as soon as possible.

#### *Probability*

The probability of a change in road condition is 'unlikely' as any changes in the condition of the local road network will be identified and repaired as soon as it is possible to do so.

#### *Magnitude*

Construction vehicle movements will occur along the Highway and access roads and it is considered that there will be no need to use local roads. Any local roads that are used will be subject to a pre- and post-condition survey, so that any deterioration is highly localised and short in duration.

#### *Receptor Sensitivity*

Receptor sensitivity depends on the type of road being used:

- Local roads – considered to be 'high' as the current condition is perceived by the majority of households surveyed during the SSES to be in a 'poor' condition; and
- Main highway – considered to be 'low' as this major road network is in a good condition, well-maintained and was originally designed to cope with the demands associated with heavy vehicles.

Table 10.8 presents the justification for assigning negative significance to Deterioration in Road Condition.

**Table 10.8 Socio Economic Impact Significance for Deterioration in Road Condition**

Event	Magnitude		Probability	Receptor Sensitivity	Significance
	Spatial Scope	Timing and Duration			
Deterioration in Road condition	Local	Changes to road condition from the transportation of construction materials will take place throughout the project and will cease after the project finishes.	Unlikely	Local Roads - High	<b>Negligible</b>
		Temporary		Main highway – Low	<b>Negligible</b>

It is considered that impacts to road condition associated with construction vehicle movements are minimised as far as practicable. Any changes to the condition of local roads will be identified and repairs will be made to restore its condition. There is no change in the future condition of the main highway expected from construction traffic. No additional mitigation is required.

## 10.8 Road and Rail Works

It is anticipated that disruption to road and railway users are likely to occur as a result of road and rail works. These are likely to occur throughout the project, particularly during Phases 2 and 7 where the EOP road junction will be established and then closed (refer to Chapter 5). In addition, it is possible there may be occasional short-duration closures and road diversions due to movements of goods.

The existing controls associated with road and rail works are:

- Procedures will be established to manage any road closures requirements and/or disruption to the rail services to duration, timings and options considered to minimise disruption. The Azerbaijan Ministry of Transport and the emergency services will be notified in advance of the road closure. Activities that may affect the railway and associated timings will be agreed with the Azerbaijan rail authority; and
- All grievances received associated with traffic and transport will be logged and appropriate corrective action determined which will be recorded in the Transportation and Traffic Management Plan.

### *Probability*

The road and rail works are 'highly likely' to result in an impact to other road users (commercial and non-business road traffic) and railway users. Road and rail users may include passengers and business owners who rely, or benefit from, the transport of goods on the networks.

### *Magnitude*

Road and rail works are expected to occur throughout the project. However, measures will be taken to minimise impacts through liaison with the relevant authorities to minimise the disruption caused.

### *Receptor Sensitivity*

Receptor sensitivity is considered to be 'high' as the road and railway network is a key transport link that connects Salyan to Baku. The railway is both a freight and passenger train route.

Table 10.9 presents the justification for assigning negative significance to the road and rail works.

**Table 10.9 Socio Economic Impact Significance for Road and Rail Works**

Event	Magnitude		Probability	Receptor Sensitivity	Significance
	Spatial Scope	Timing and Duration			
Road and rail works	Local, and regional	Road and rail works are expected throughout the project but disruption is expected to be of short duration.  Temporary	Highly likely	Local, regional and national businesses – High	<b>Negative</b>

It is considered that local and regional impacts associated with Road and Rail Works are minimised as far as practicable. No additional mitigation is required.

## 10.9 De-manning

Training and Employment is discussed in Chapter 5 Section 5.9. As activity reduces towards the end of the project, employment levels will be reduced.

The existing controls associated with de-manning are:

- Planning for the conclusion of worker contracts will start at the outset of the SD2 Infrastructure Project through implementation of the Training Plan (discussed in Section 10.6); where it is anticipated that workers will learn new skills that make them more attractive in the job market; and
- Staff communications will ensure that the workforce is aware of project progress and expected completion dates.

### *Probability*

Within the local community:

- There are unlikely to be enough vacancies available locally that can immediately absorb the large numbers of workers, many of whom will have similar non-professional skills sets to offer the (same) employment market. This is reflected by the currently high levels of unemployment in the local communities;
- The non-professional workforce taken from the local communities will be a result of 'targeted employment' and workers may not have the skills (or motivation) to proactively seek-out new employment; and
- A significant proportion of the workforce may not have secondary sources of household income, or have been able to save from their previously salary.

De-manning has the potential to lead to an increase in psychological stress associated with the uncertainty associated with future sources of household income, a reduction in general well-being, quality of life, and reduced access to private healthcare. Such changes may disrupt family life, personnel relationships and, potentially, affect the welfare of children. However, it is understood that the works associated with the main SD2 Project will begin immediately following the completion of the SD2 Infrastructure Project. The SD2 Project will provide further opportunities for employment and therefore the probability of impacts associated with de-manning are considered 'unlikely'.

### Magnitude

Impacts associated with de-manning will likely commence prior to end of the project as manning levels decrease due to decrease in project activities. Workers able to seek alternative employment, or return to their previous role before employment may only experience a temporary change in household income. Workers who are unable to seek alternative sources of work may experience de-manning impacts across a longer timescale.

### Receptor Sensitivity

Receptor sensitivity is considered to be 'high' as a significant proportion of the workforce will have been specifically targeted for employment, and some workers may not be able to obtain alternative employment.

Table 10.10 presents the justification for assigning negative significance to de-manning.

**Table 10.10 Socio Economic Impact Significance for De-manning**

Event	Magnitude		Probability	Receptor Sensitivity	Significance
	Spatial Scope	Timing and Duration			
De-manning	Local	De-manning will likely commence prior to end of the project as manning levels decrease however it is expected that the main SD2 Project will provide relevant employment opportunities for workers.  Permanent	Unlikely	Local community – High	<b>Negligible</b>

It is considered that local impacts associated with de-manning are minimised as far as practicable and no additional measures are required. Employment opportunities generated with the SD2 Project will likely reduce the impact of the de-manning of the SD2 Infrastructure Project.

## 10.10 Indirect Impacts

In addition to the direct socio-economic impacts from the project, it is anticipated a number of indirect impacts may occur. These are induced impacts that do not directly arise from the SD2 Infrastructure Project itself but may occur as a result of the project and may be due to a combination of direct impacts.

### 10.10.1 Local Economic Impacts

The combination of significant increases in local employment and payment of monetary compensation to people whose livelihoods have been impacted, will result in a rapid and temporary increase in local capital flows. Whilst affected individuals and business owners will typically consider this to be a positive change, there is a potential for local inflation to occur through a sudden increase in the demand for the same types of good and services. Business owners may also seek to maximise the local rise in household income by increasing prices to take full advantage of increased capital available.

The requirement for professional staff to be taken from the local communities may divert individuals from existing professional roles, to the SD2 Infrastructure Project with the aim of securing higher paid employment. For example, if large numbers of professional public workers (such as health care staff, teachers for example) depart their current employment



then such changes may have negative consequences to the local community, particularly to the quality of education and social support provided to vulnerable groups.

### **10.10.2 Social Conflict**

There is the potential for conflict to occur from (perceived or actual) competition between individuals seeking jobs. Such conflicts could occur between members of the same settlement, between individuals from the local communities, or between 'local' and 'non-locals'. Such conflicts may be exacerbated by pre-existing tensions between groups of people and in particular, between non-locals and vulnerable groups (such as IDPs) who may perceive they are being excluded.

### **10.10.3 Anti-Social Behaviour**

Increases in local capital flows may result in an increase in anti-social behaviour and family breakdown associated with greater alcohol and substance abuse, prostitution, domestic violence and desertion. This will result in extra demands placed upon local social welfare infrastructure such as first aid centres, educational establishments, social services and the State police.

### **10.10.4 Mitigation of Indirect Impacts**

It is anticipated that the potential increase in inflation, possible social conflict and rise in anti-social behaviour will be mitigated through BP's social investment program. This will be implemented in parallel with the Training Programme to develop workers skills and development to maximise their chances of finding alternative sources of work.

## **10.11 Summary of SD2 Infrastructure Project Residual Socio-Economic Impacts**

For all socio-economic impacts assessed it has been concluded that impacts are minimised as far as practicable and necessary through the implementation of the existing control measures. No additional mitigation is required.

Table 10.11 summarises residual socio-economic impacts.

**Table 10.11 Summary of SD2 Infrastructure Project Residual Socio-Economic Impacts**

Event	Magnitude		Probability	Receptor Sensitivity	Significance
	Spatial Scope	Timing and Duration			
<b>Direct Impacts</b>					
Disruption and access restrictions (SD2 Infrastructure Area)	Local	All SD2 Infrastructure area will be temporarily fenced during works to prevent unauthorised access.  Temporary impact	Highly likely	Local herders – High	<b>Moderate – major negative</b>
		Up to approximately 115 hectares will be permanently removed from use for herders.			
		Permanent impact			
Disruption and access restrictions (Pipeline Landfall Area)	Local	The majority of the SD2 Infrastructure Area will be temporarily fenced during works (between March 2012 and June 2013).  Temporary impact	Highly likely	Recreational fishermen - Low	<b>Negligible</b>
			Highly likely	Commercial fishermen - Medium	<b>Negative</b>
			Highly likely	Recreational users - Low	<b>Negligible</b>
			Unlikely	Shoreline property values - Low	<b>Negligible</b>
Employment creation	Local	Employment will occur throughout the project, and is expected to peak between April 2012 and November 2012.  Temporary impact	Highly likely	Local community - High	<b>Moderate-Major Positive</b>
	Regional		Likely	Regional community – Medium	<b>Positive</b>
Training and skills development	Local	Training will commence prior to the project activities and continue throughout the project.	Highly likely	Local community – High	<b>Moderate-Major positive</b>
	Regional	Permanent	Highly likely	Local community – Medium	<b>Positive</b>
Procurement of goods and services	Local, and Regional	Procurement will take place throughout the project and benefits will cease shortly after the project finishes.  Temporary	Highly likely	Local and regional businesses - High	<b>Moderate-Major positive</b>
	National			National businesses - High	<b>Positive</b>
Disruption and impact to community safety associated with construction vehicle movements (offsite)	Local	Off site traffic movements will take place throughout the project.  Temporary	Unlikely	Road users and local community – High	<b>Negative</b>

Event	Magnitude		Probability	Receptor Sensitivity	Significance
	Spatial Scope	Timing and Duration			
Deterioration in Road Conditions	Local	Changes to road condition from the transportation of construction materials will take place throughout the project and will cease after the project finishes.  Temporary	Highly unlikely	Local Roads – High Main highway – Low	<b>Negligible</b>
Road and rail works	Local, and regional	Road and rail works are expected throughout the project but disruption is expected to be of short duration.  Temporary	Highly likely	Local, regional and national businesses – High	<b>Negative</b>
De-manning	Local	De-manning will likely commence prior to end of the project as manning levels decrease however it is expected that the main SD2 Project will provide relevant employment opportunities for workers.  Permanent	Unlikely	Local community – High	<b>Negligible</b>

Indirect socio-economic impacts include:

- Potential increases in inflation;
- Possible social conflicts; and
- A rise in anti-social behaviour.

It is anticipated these impacts will be mitigated through BP's social investments program and through public awareness campaigns, provision of family counselling and financial planning support to employed workers to encourage the income gained from employment to be used in a responsible manner.

## 11. Cumulative and Transboundary Impacts and Accidental Events

### Contents

11.1	Introduction.....	2
11.2	Cumulative and Transboundary Impacts .....	2
11.3	Cumulative Assessment.....	2
	11.3.1Cumulative Impact Between Separate Project Impacts.....	2
	11.3.2Cumulative Impact With Other Projects .....	3
	11.3.3Approach to Cumulative Assessment .....	4
	11.3.4Assessment of Cumulative Impacts.....	5
	11.3.5Conclusion .....	10
11.4	Accidental Events.....	10
	11.4.1Overview .....	10
	11.4.2Potential Accidental Events.....	10
	11.4.3Measures to Mitigate Accidental Events .....	11
	11.4.4Spill Response .....	15
	11.4.5Spill Reporting.....	17

### List of Figures

Figure 11.1	Location of the Planned or Under Construction Projects in the Terminal Vicinity ..	4
Figure 11.2	Potential Overlap Between Planned and Under Constructions Project and the SD2 Infrastructure Project.....	5
Figure 11.3	Main Drainage Catchment Areas in the Vicinity of the Terminal Including Modifications Associated with Proposed Qizildas Cement Plant .....	8
Figure 11.4	Location of Existing Pipelines .....	12
Figure 11.5	Indicative Locations of EOP Concrete Barriers and Buried Pipeline Protection...	13
Figure 11.6	BP's Incident Management System.....	16
Figure 11.7	Site Emergency Response Organisation.....	17

### List of Tables

Table 11.1	Oil Spill Response Tiers.....	16
------------	-------------------------------	----

## 11.1 Introduction

This Chapter of the Shah Deniz 2 (SD2) Infrastructure Project ESIA discusses:

- Cumulative and Transboundary Impacts; and
- Accidental Events that could potentially occur during SD2 Infrastructure Project works and the control, mitigation and response measures designed to minimise event likelihood and impact.

## 11.2 Cumulative and Transboundary Impacts

As discussed within Chapter 3, cumulative impacts arise from:

- Interactions between separate project-related residual impacts; and
- Interactions between project-related residual impacts in combination with impacts from other projects and their associated activities.

As outlined in Chapter 1 of this ESIA, the SD2 Project comprises the next stage of development of the SD Contract Area. The SD2 Infrastructure Project includes the works required prior to the construction, installation, commissioning and operation of the onshore SD2 Project facilities within the SD2 Expansion Area at the Terminal.

The existing ACG Phase 1, 2 and 3 and SD1 facilities at the Terminal have been operational since 2007. The effects of these projects on the environmental and socio-economic environments are therefore incorporated into the existing baseline as presented in Chapters 6 and 7. The potential for cumulative impacts with other projects have therefore been determined based on a review of available information relating to projects in the Terminal vicinity, which are of a scale that has the potential to result in cumulative impacts.

## 11.3 Cumulative Assessment

### 11.3.1 Cumulative Impact Between Separate Project Impacts

A detailed assessment of environmental and socio-economic project impacts, based on expected activities and events, is presented in Chapters 9 and 10 of the ESIA. The assessment takes into account each activity and the existing controls in place to manage the impact. No requirement for additional mitigation was identified and all impacts were considered to be minimised as far as practicable.

The cumulative effect of activities resulting in air emissions and noise are considered in Sections 9.3 and 9.4 of Chapter 9 respectively. No significant cumulative impact to air quality was identified with increases in concentrations of nitrogen dioxide (NO<sub>2</sub>) from onsite and offsite traffic and plant less than 2% of the current background concentration, leading to no expected exceedance of the relevant long term air quality standard (40µg/m<sup>3</sup>).

The assessment of the cumulative impact associated with noise generating activities was undertaken assuming a worst case scenario where proposed piling activities are undertaken at the same time as the highest on site plant and vehicle activity. It was determined that, with appropriate screening of the pneumatic hammers, and through notification of the local community of the trial piling works, the cumulative effect of noise would be appropriately mitigated.

The cumulative effect of all expected project activities will be managed through the implementation of a number of management plans as described within Chapter 12. For example, a Nuisance Management Plan will be prepared and implemented that details the processes used to prevent nuisance associated with construction noise, light from construction work areas, odours, pests and vermin. In addition a Community Interaction and Social Impact Management Plan will be implemented and maintained as a mechanism of communicating with the community and responding to community grievances.

Given the existing control measures in place, it is considered that the appropriate measures are in place to appropriately mitigate and manage potential cumulative effects between project related residual impacts. No additional mitigation is required.

### 11.3.2 Cumulative Impact With Other Projects

Based on a review of available information it is understood that the following projects, which have the potential to interact with the impacts of the SD2 Infrastructure Project based on their location and scale, are planned or under construction in the vicinity of the Terminal (refer to Figure 11.1):

- **Qizildas Cement Plant** – new cement plant to be located approximately 4km north of the Terminal. The project incorporates dry kiln technology and will be designed to produce up to 2,000,000 tonnes of cement per annum from raw materials supplied from local quarries in the Garadagh and Absheron regions. A new road to enable construction and operational vehicles to access the plant from the Baku-Salyan Highway is planned and the project also includes a railway spur from the railway line between the Terminal and Umid. Plant construction was initially planned to commence in 2009 and last 28 months although it is understood that this is yet to commence. Construction of the new road is thought to have started although the programme for completion of the road works is not known. Impacts associated with the operational phase of Qizildas Cement Plant have been assessed within an ESIA completed in 2009<sup>1</sup>;
- **Garadagh Dry Kiln Project** – project comprises works to upgrade the existing Garadagh cement works which lies approximately 6km to the east, to install dry kiln technology and increase production. It is understood that works commenced in August 2008 are due to be completed by the end of 2011. Impacts associated with the project once operational have been assessed within an ESIA completed in 2009<sup>2</sup>; and
- **New Highway Junction** – a new junction is planned immediately to the south of the Terminal which will connect to the new Terminal access road that forms part of the SD2 Infrastructure works. The junction is planned to include slip roads, a bridge over the highway and connection to the new Terminal access road passing over the railway line. It is expected that the junction will be constructed during Phase 4 of the SD2 Infrastructure Project (March 2011 to June 2012). The design of the junction is the responsibility of the Highways Authority. No ESIA has yet been completed for this project.

In addition to these projects it is understood that traffic flow along the Baku- Salyan Highway has increased in recent years<sup>3</sup>. The Azerbaijan Highways Authority have indicated that traffic flows are expected to increase in the future due to further development to the north and south of Sangachal Town, specifically following the construction of a new port facility near Alyat and a new ship building industry in Silah. To provide capacity for the increased traffic flows, a requirement has been recognised to widen the highway to four lanes in each direction. Full details of the upgrade works to the Baku-Salyan Highway (such as schedule and extent of the works) are not available.

---

<sup>1</sup> Qizildas Cement Factory ESIA , 2009

<sup>2</sup> ERM (2009) Garadagh Cement Project New Dry Kiln 6: ESIA

<sup>3</sup> Per comms, Head of the Technical Division, Azerbaijan Highway Authority, 2010

**Figure 11.1 Location of the Planned or Under Construction Projects in the Terminal Vicinity**



Note: Location of Rail Spur is approximate as no clear map is presented in the Qizildas ESIA report.

### 11.3.3 Approach to Cumulative Assessment

#### Assumptions

Key assumptions made for the cumulative assessment are:

- The construction programme for the Garadagh Cement Plant upgrade project was provided in the ESIA<sup>4</sup> and it is understood that the project is on target for completion in 2011. Based on this information, the cumulative assessment only considers cumulative impacts associated with the operational phase of this project; and
- The Qizildas Cement Plant ESIA states that the construction programme will be 28 months extending from 2009 to 2011<sup>5</sup>, although construction has not yet begun. A recent press release<sup>6</sup> indicates that the operation of the plant is expected in late 2013, however this is unconfirmed. Based on this data it is assumed that there will be no overlap of the SD2 Infrastructure Project with the operation of the Qizildas Cement Plant, but the construction phases are likely to overlap; and
- It is assumed that the construction programme of the Baku-Salyan Highway junction will overlap with the SD2 Infrastructure Project activities between March 2012 and June 2013.

The highways upgrade works have not been assessed as no details are known.

Based on the assumptions, Figure 11.2 shows the potential overlaps of the cumulative projects with SD2 Infrastructure Project.

<sup>4</sup> ERM (2009) Garadagh Cement Project New Dry Kiln 6: ESIA.

<sup>5</sup> Qizildas Cement Factory ESIA, 2009.

<sup>6</sup> Press release: <http://www.abc.az/eng/news/52007.html> (2011).



**Figure 11.2 Potential Overlap Between Planned and Under Construction Project and the SD2 Infrastructure Project**

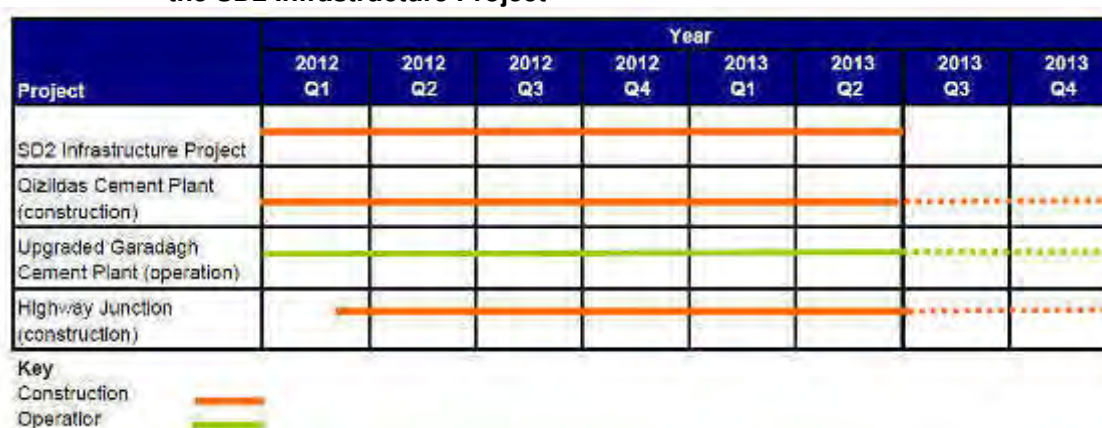

### 11.3.4 Assessment of Cumulative Impacts

#### Traffic Disruption

The Baku-Salyan Highway is the main traffic route in the local area and is expected to be used by construction and operational traffic associated with all the planned and under construction projects.

As the Garadagh Cement Plant project involves upgrading existing facilities; changes to the traffic flows are expected to be minimal. A key objective of the Garadagh Cement Plant project is to increase the capacity of the plant (from 2,600 tonnes/day to 4,000 tonnes/day) however, due to internal traffic issues within the site, it is planned to increase the volume of products transported by rail<sup>7</sup>. This has not been quantified within the ESIA, but it is considered likely to result in similar, or fewer, numbers of vehicles from the Garadagh Cement Plant using the Highway compared to present.

Estimated traffic flows associated with construction of the Qizildas Cement Plant and the new Baku-Salyan Highway junction are unknown. However, the SD2 Infrastructure Project will contribute, at the project's peak, 162 vehicles per day which equates to 1.62% of the total traffic flow. Given that the scale of Qizildas Cement Plant is greater than the SD2 Infrastructure Project, it is likely that construction traffic will be of a greater magnitude. As the scale of the works involved for the new Baku - Salyan Highway junction will be smaller than the SD2 Infrastructure Project, it is assumed construction traffic flows will be lower.

Based on these other projects, it is expected that throughout the SD2 Infrastructure Project programme, there will be an increase in the volumes of traffic using the Highway. Assuming construction of the Qizildas Cement Plant commences in 2012, the majority of the increases in traffic flows on the Highway are expected to relate to this project with a smaller contribution expected from the SD2 Infrastructure Project.

As described within Section 12, the SD2 Infrastructure Project construction contractor will be expected to implement a Traffic Management Plan, one of the aims of which will be to minimise impacts to road users and ensure that adherence to BP's strict procedures associated with vehicles and safe driving are enforced. The Traffic Management Plan will be subject to regular review and update and will take into account any changes in traffic flows or routing issues during the project duration. It is assumed that, as for the SD2 Infrastructure Project, any necessary road closures or major roadworks associated with the planned or under construction projects will be notified to the Azerbaijan Highways ahead of the works, to ensure necessary traffic diversion notices and other arrangements, can be put in place. It is

<sup>7</sup> ERM (2009) Garadagh Cement Project New Dry Kiln 6: ESIA.

therefore considered that the SD2 Infrastructure Project's contribution to potential traffic impacts are minimised as far as possible. No additional mitigation is required.

### **Noise - Traffic**

Increases in traffic flow will result in an increase in traffic noise. The SD2 Infrastructure Project is expected to contribute a maximum 1.62% increase in traffic flows along the Highway, leading to an increase in noise levels at receptors of less than 1dB(A). As discussed in Chapter 9 Section 9.4.1 an increase of 25% would be required to increase noise levels by 1dB(A) or more. A 3dB(A) increase would be achieved if traffic flows double. While traffic flows associated with the Qizildas cement plant construction traffic are not known, it is not expected that the contribution will result in a doubling of flows and noise levels at receptors are not expected to increase by more than 3dB(A). The contribution of the SD2 Infrastructure Project to noise impacts associated with traffic is considered to be minimised as far as possible. No additional mitigation is required.

### **Noise - Construction including Piling**

It is likely that activities associated with SD2 Infrastructure Project will overlap with construction of the Highway junction. The extent of works associated with the junction is not known although it is likely that the slip roads and bridge construction will include piling works. These will need to be managed by the relevant construction contractor to minimise the noise impacts at the local communities. As demonstrated within Chapter 9 Section 9.4.1 the SD2 Infrastructure Project activities (onsite plant and vehicles and piling works) have the potential alone to result in noise levels near to the applicable noise limit or current ambient noise levels at receptors if appropriate mitigation is not in place. It will be the responsibility of the Highway Junction construction contractor and the SD2 Infrastructure Project contractor, should works overlap, to liaise to ensure that impacts are minimised through appropriate consultation with the local community, scheduling of works and use of appropriate mitigation.

### **Impacts to the Atmosphere (GHG Emissions)**

Increases in man-made GHG (including carbon dioxide and methane) are widely accepted as contributing to changes in the energy balance of the world's climate system, creating an overall increase in average global temperatures<sup>8</sup>.

It is estimated that a total of 137 ktonnes of GHG emissions will be released to the atmosphere as a result of SD2 Infrastructure Project activities (refer to Chapter 5 Table 5.6). The Garadagh Cement Plant is expected to emit approximately 435 ktonnes of GHG emissions across the duration of the SD2 Infrastructure Project<sup>9</sup>. Projected GHG emissions expected to be generated during the construction phase of Qizildas Cement Plant and works on the new Baku-Salyan Highway are not available. However, it is anticipated that GHG emissions for the Qizildas Cement Plant construction are likely to be substantially higher than for the SD2 Infrastructure Project given the scale of the works proposed across a similar timescale (i.e. 2 year construction programme for the Qizildas Cement Plant as compared to 18 months for the SD2 Infrastructure Project).

Projected GHG emissions from SD2 Infrastructure Project activities have been compared against the United Nations Framework Convention on Climate Change (UNFCCC) annual predictions for Azerbaijan<sup>10</sup> and are estimated to constitute approximately 0.15% of Azerbaijan's national GHG emissions during the project programme. This represents an insignificant contribution to the predicted national GHG emissions.

<sup>8</sup> Fourth Assessment Report of the United Nations Intergovernmental Panel on Climate Change - Climate Change 2007, IPCC, 2007.

<sup>9</sup> GHG emissions calculated for 18 month period from data within ERM (2009) Garadagh Cement Project New Dry Kiln 6: ESIA.

<sup>10</sup> UNFCCC forecast GHG emissions for Azerbaijan for 2010 used as basis.

### **Impacts to the Atmosphere (Non-GHG emissions)**

The Qizildas Cement Plant and Garadagh Cement Plant projects are located 4km north and 6km east from the SD2 Infrastructure Project, respectively.

The ESIA for Garadagh Cement Plant project demonstrates that air quality is unlikely to be affected more than 2km from the source of emissions when the plant is operational. In addition, dust impacts are shown to be limited to the immediate vicinity of the plant. This is, in part, due to the technologies used for control of dust from the cement process which includes electrostatic precipitators and bag filters, and the control of particulates from the proposed increase in coal use within the kilns through use of bag filters on the associated coal mill. It is expected, based on air quality modelling, that there will be little change in non-GHG emissions greater than 1km from the construction area. The impacts to air quality from the construction phase of Qizildas Cement Plant are expected to occur within the plant boundary.

On the basis of the assessments undertaken above regarding traffic disruption and traffic noise, it is considered that cumulative impacts associated with non-GHG emissions generated by offsite traffic are likely to be insignificant. Impacts associated with the SD2 Infrastructure Project alone will be appropriately mitigated and managed.

### **Changes to Hydrology**

There are number of sensitive receptors which may be at risk of flooding from modification to the local hydrology:

- Sangachal Town;
- Sangachal Power Station;
- The railway;
- The Baku-Salyan Highway; and
- The Caravanserai located just to the south of the Shachkaiya Wadi channel immediately upstream of railway bridge 'B4'.

As described in Chapter 5 Section 5.5.3, the SD2 Infrastructure Project includes wadi clearance works which will involve upgrading the existing western and central wadi sea outfalls. These have been partially blocked by silt and other materials.

It is understood that the scope of the Qizildas Cement Plant project includes modifications to a significant part of the upper Shachkaiya Wadi catchment. The exact nature and extent of these planned modifications are not fully known although is expected to involve quarrying for building stone. Such a modification is likely to increase the impermeable extent within the catchment, resulting in increased runoff and shorter response times to rainfall.

Hydrological modelling (refer to Appendix 9E) has been undertaken to assess the impact of the potential modifications (refer to Figure 11.3). The proposed cement plant will have three main impacts on the drainage and runoff in these upper catchment areas:

- Alteration of existing drainage routes and flow patterns;
- Increases in the total impermeable area covered by roads and buildings; and
- Increases in the impermeable areas and runoff rates associated with an expansion of quarrying activities.

**Figure 11.3 Main Drainage Catchment Areas in the Vicinity of the Terminal Including Modifications Associated with Proposed Qizildas Cement Plant**

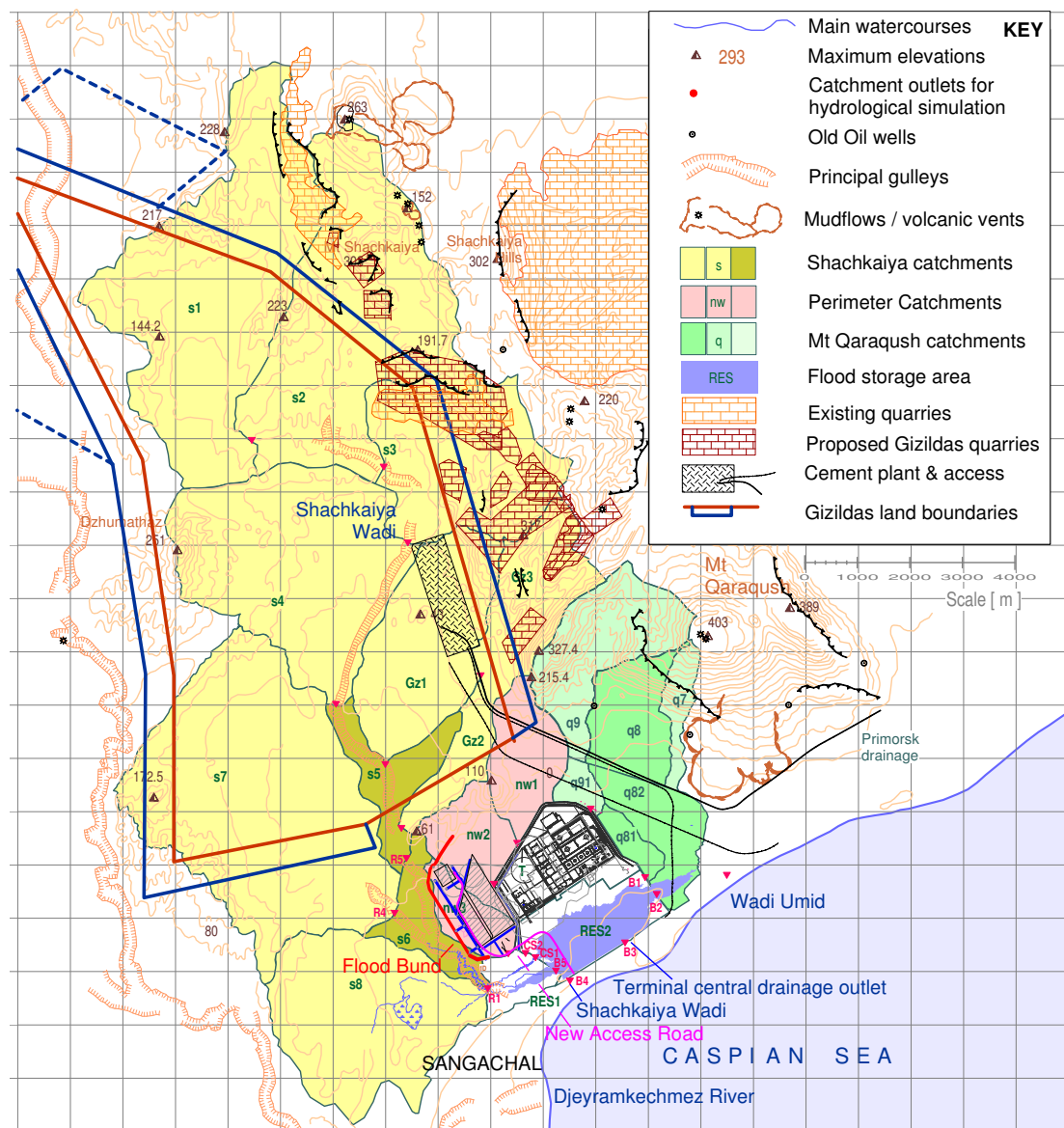

© Water Resource Associates Ltd. Based on Soviet mapping at 1:50,000 scale, with WRA data added

Hydrological modelling indicated that the 100 year peak flow of the Shachkaiya Wadi would increase from 61m<sup>3</sup>/s to 80m<sup>3</sup>/s. As the actual scale of the Qizildas Cement Plant development is not clear, the changes in peak flow predicted use a worst case scenario. The impact of the 100 year peak flows are expected to result in impacts to the following key receptors:

- The flood level of Sangachal Town has the potential to increase by up to 0.4m; and
- The flood level of the Caravanserai has the potential to increase by 0.5m, resulting in inundation of the building and its compound to a depth of 0.4 to 0.5m.

In isolation, the SD2 Infrastructure Project is not expected to have a significant impact to flood levels at any of the key receptors. However, once the project is completed the existing flood risk to the Highway in the vicinity of bridge 'B6' will remain. The elevated Highway Junction is planned to be constructed in this location and once complete it will offer an alternative route for highway users in the event that the highway floods.

## Employment

The SD2 Infrastructure Project is expected to create between 450 and 700 temporary jobs. Additional temporary jobs will be created by the construction of the Qizildas Cement Plant and the new Baku-Salyan Highway Junction, although the likely workforce requirement is not available.

The Garadagh Cement Plant currently employs approximately 585 workers which is expected to reduce with the increased efficiency of the plant due to the upgrade works, leading to the loss of 82 jobs. The loss will be partially compensated by business expansion in the next 3 years which is predicted to create 54 permanent jobs. The net impact at the Garadagh Cement Plant in the next three years will therefore be a loss of 28 jobs<sup>11</sup>.

Despite job losses associated with the Garadagh Cement Plant, there will be a positive impact on employment throughout the duration of the SD2 Infrastructure Project. Jobs associated with the SD2 Infrastructure Project will be temporary, but will provide employees with an opportunity to develop their work skills and experience. Overall, the cumulative impact of the planned projects on local employment is beneficial. This assumes that the local content goals and employment and training initiatives detailed within Chapter 12 for the SD2 Infrastructure Project are also implemented for the Qizildas Cement Plant and the New Baku - Salyan Highway Junction projects.

## Economic Benefits

The contribution of the SD2 Infrastructure Project, Garadagh Cement Plant upgrade, Qizildas Cement Plant and the new Baku-Salyan Highway Junction will lead to increased economic flows at a local regional and national level. This cannot be quantified as the expected economic benefits from these projects are not stated. It is likely, however, that the economic benefits from the Garadagh and Qizildas Cement Plants will be more substantial than the SD2 Infrastructure Project.

## Community Initiatives

The Garadagh Cement Plant has implemented a Corporate Social Responsibility (CSR) programme which is focused on capacity building, poverty reduction, enabling business environment and the development of social infrastructure<sup>9</sup>. Company employees, their families and local communities with a particular focus on Sahil community, are targeted by the CSR program. The Centre for Disabled Children and Sport School at Sahil are amongst local institutions that receive funding by the CSR programme. Examples of other recent CSR projects are funding of medical facilities (first aid station and hospital in Sahil, national oncology centre), repair of roads in local communities, funding of public events and public health awareness campaigns.

BP's community investment programme is described in Chapter 7, Section 7.5. BP is currently involved in educational programmes which provides support to people from a young age and continues to a university research level. BP also supports the development of local suppliers through training and financing programmes, building skills and sharing BP's internal standards and practices as appropriate. Such activities enable a greater number of local businesses to participate in their supply chain.

The Garadagh Cement Plant and BP have both designed and implemented, long-term community investment programmes. These contributions, together with ongoing and meaningful stakeholder relationship activities, will result in positive impacts at an individual and community level. The cumulative impact from BP's community investment programmes and of the Garadagh Cement Plant CSR programme is complimentary and will have a positive impact upon local communities.

---

<sup>11</sup> ERM (2009) Garadagh Cement Project New Dry Kiln 6: ESIA.

### **11.3.5 Conclusion**

The assessment of cumulative impacts presented in Section 11.3.4 demonstrates that negative cumulative impacts associated with the SD2 Infrastructure Project and other projects in the vicinity of the Terminal are expected to be limited.

The greatest potential for a negative, cumulative impact to occur is linked to the level of traffic disruption associated with the SD2 Infrastructure Project, assuming that the construction schedule for Qizildas Cement Plant overlaps. There is also potential for cumulative noise impacts at sensitive receptors associated with the SD2 Infrastructure Project and construction works for the new Highway Junction. It will be necessary for the SD2 Infrastructure Project construction contractors and Highways Authority to ensure these cumulative impacts are minimised, through careful scheduling of works and use of appropriate mitigation measures.

Positive cumulative impacts are expected to occur from employment, increased economic flows and community investment programmes. In addition, construction of the highway will result in a positive impact in relation to flood risk as the junction, when complete, will provide an alternative safe route should the highway be flooded during a major flood event and will not compromise the safety of the Terminal or road users.

## **11.4 Accidental Events**

### **11.4.1 Overview**

Accidental events are considered separately from routine and non-routine activities as they only arise as a result of a technical failure, human error or as a result of natural phenomena such as a seismic event.

This section addresses the potential spills of various types that may occur and the measures to mitigate the spill or the cause of the spill. These include:

- Design measures, where the elements of project Base Case Design have been incorporated specifically to prevent or minimise the spill occurring;
- Construction measures i.e. how the construction methodology has been determined in order to minimise accidental events leading to spills; and
- Procedures and controls to be followed throughout the works to prevent or avoid spills and subsequent impact to the environment.

Spill response and reporting of spills is also discussed.

### **11.4.2 Potential Accidental Events**

Potential accidental events associated with the SD2 Infrastructure Project were identified through a review of:

- Spills that occurred during previous ACG construction projects; and
- Potential for accidental events based on SD2 Infrastructure Project activities.

The type, size and cause, during previous ACG projects were thoroughly documented and give an indication of where spill prevention measures should be focused for the SD2 Infrastructure Project. Such measures are documented in Section 13.7.4.1 of the COP ESIA. The findings of the review were that the root causes of spills were equipment failure (hoses, valves, gaskets etc) and human error. Spills of hydraulic fluid resulting from hose failure accounted for a greater proportion of spills than any other single source. Specific measures associated with maintenance and operator training was therefore identified to address these issues.

Potential accidental events associated with the SD2 Infrastructure Project works include:

- Impact to a pipeline(s) within the existing pipeline corridor during construction activities;
- Loss of containment from fuel tanks within the construction camp/facilities area;
- Loss of containment from a fuel bowser, drum, Intermediate Bulk Container or fuel transfer container;
- Minor spills associated with leaks/small spills;
- Failure of the sewage treatment plant;
- Overflow of underground oil separators or septic tanks;
- Release of concrete into watercourses or the Caspian Sea; and
- Flood events causing silty water runoff from stockpiles and exposed ground.

Minor spill incidents are classified as those which can be handled immediately by on site personnel and are less than 50 litres. They will be managed and controlled as described within Section 11.4.4 below.

### **11.4.3 Measures to Mitigate Accidental Events**

#### **Design Measures**

##### ***Pipeline Mapping***

The location of the pipelines in the existing pipeline corridor to the south of the Terminal has been a key issue in informing the project design and construction methodology. A rigorous access road route selection and design process has been followed to minimise the likelihood of disturbance to the existing pipelines (refer to Chapter 4). This process has included a mapping exercise to identify the majority of pipelines, detailing the location, contents, size and the conditions of the existing pipelines (refer to Figure 11.4). Prior to construction, it is planned to undertake a further survey to identify any pipelines that have not yet been identified including depth and conditions.

The following measures have been incorporated into the Base Case Design and construction strategy to minimise potential impacts to existing pipelines:

- The design of the new access road incorporates a 50m exclusion zone around the existing pipelines<sup>12</sup>;
- The existing disused railway embankment and existing track and crossing points across the pipelines will be used to avoid unnecessary disturbance;
- Concrete slabs (250mm thick) to be placed across buried pipelines to provide adequate protection from above for temporary construction traffic crossings;
- It is not planned to undertake any excavation of drainage channels or pipelines across any existing pipelines, except where nominal protection against scouring from surface run-off is required; and
- The flood protection berm will be a maximum of 1m deep over the existing pipelines to prevent overloading.

---

<sup>12</sup> 50m exclusion zone is not applied to SOCAR export pipelines. These will be 5m from extent of the new access road embankment, which will be engineered to avoid loading or disruption to the pipelines.



**Figure 11.4 Location of Existing Pipelines**

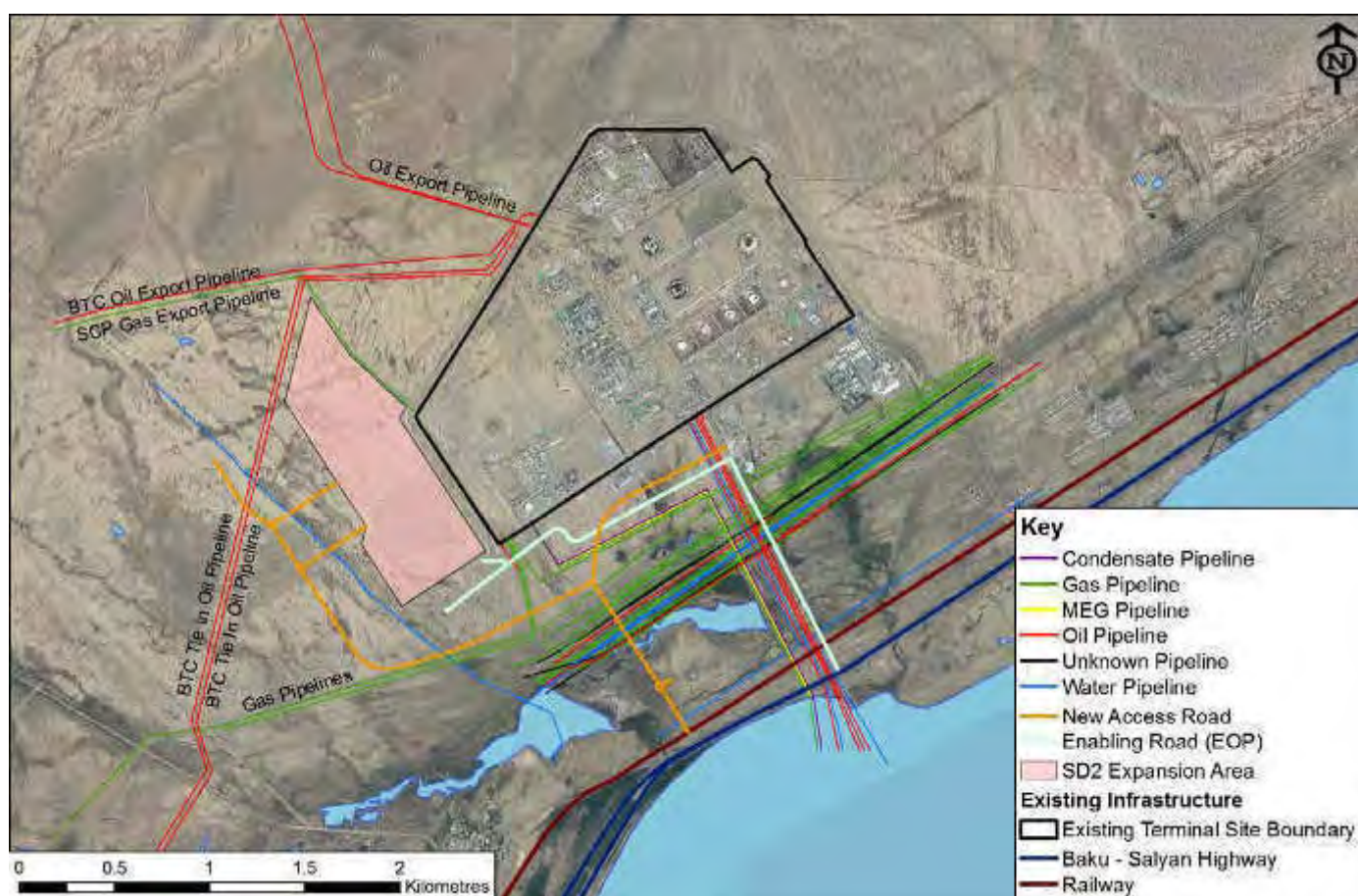

### ***Culverts/Crossings***

The new access road design includes culverts and crossings to enable the road to pass over the existing pipeline corridor (refer to Chapter 5 Figure 5.8 for culvert & crossing locations). To minimise any risk of an accidental event during the construction of the road through the use of heavy machinery, it is planned to use pre-cast construction methods. In addition, the crossings used to cross gas pipelines will incorporate vehicle barriers. The purpose of these is to prevent vehicles accidentally striking the pipelines and potentially compromising pipeline integrity.

The state pipeline corridor is located to the south of the Terminal through an area of soft and unstable ground. To provide adequate stability for the new access road, piles may be required in this area. If needed, mini piles will be used; driver or displacement piles will not be used. The piling system to be used will be required to meet the following criteria:

- Minimise ground disturbance during installation;
- Enable installation using light weight equipment;
- Avoid lateral loading;
- Minimise compromising pipeline integrity by undertaking piling by reaching over sensitive pipelines;
- Minimise concreting operations; and
- Minimise heavy lifts.

**EOP Road - Concrete Barriers and Buried Pipeline Protection**

There are a number of exposed gas pipelines located perpendicular to the disused EOP road, which will be reinstated for the SD2 Infrastructure Project and used for access until the new access road has been completed. To protect these pipelines from vehicles accidentally striking the pipelines, modular concrete barriers (refer to Figure 11.5) will be placed along the edge of the EOP road.

Along the EOP road, pipelines have been previously installed through the road. To prevent the pipelines (both buried and above ground) from excessive loads associated with vehicle movements or damage from remediation works the following will be undertaken:

- The position of the pipelines will be clearly marked with suitable flags, stakes and other markers at the crossings; and
- The use of suitable bridging reinforcement concrete relieving slabs will be used.

**Figure 11.5 Indicative Locations of EOP Concrete Barriers and Buried Pipeline Protection**

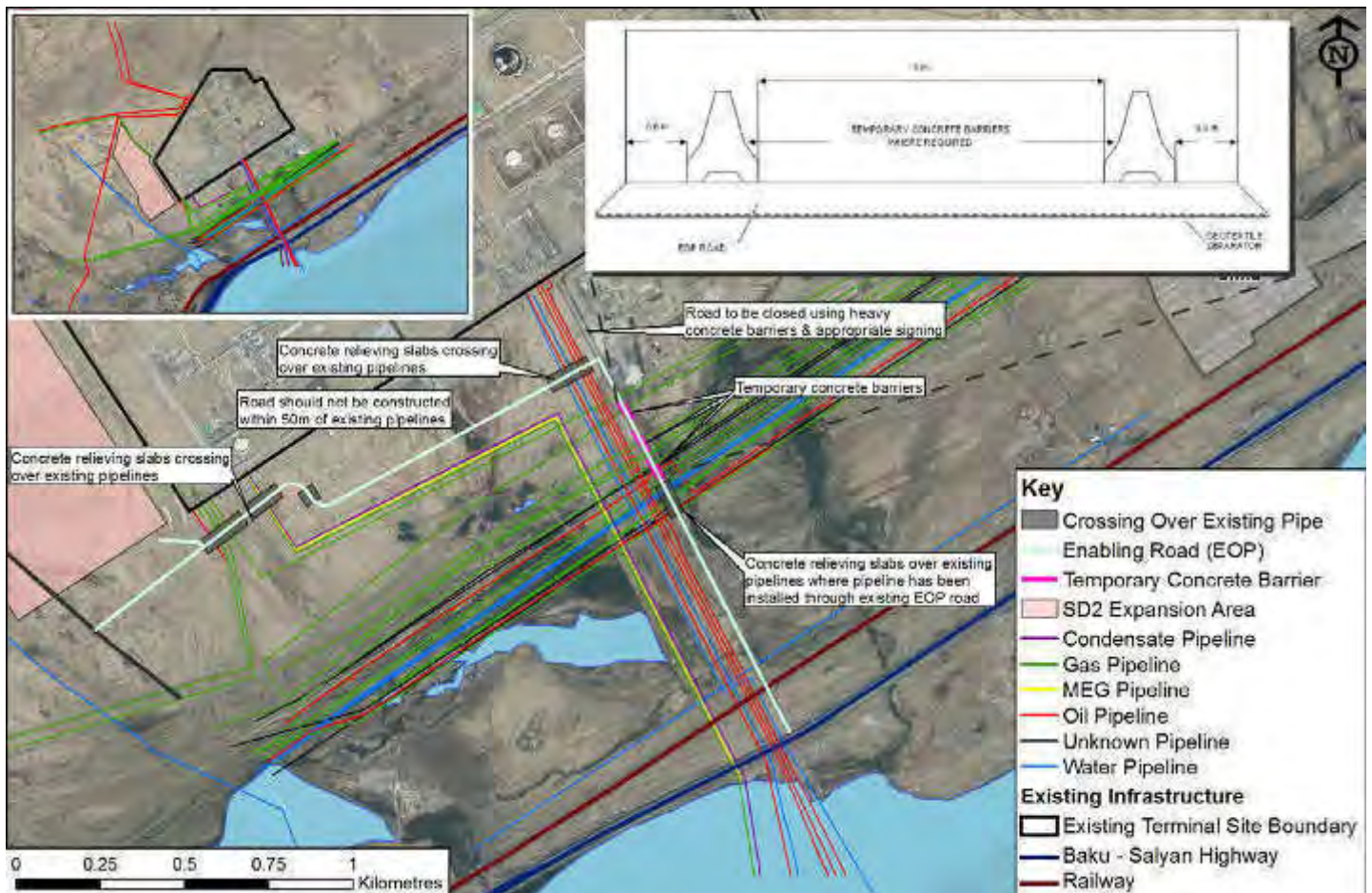

**Bunding and Containment**

Fuel storage and tanker movements in the Construction Facilities Area and in the initial site compound during the early stages of the project, will be undertaken within designated bunded areas. These areas will drain to a dedicated oil water separator which will be designed to ensure that that discharges meet relevant oil in water standards<sup>13</sup>.

<sup>13</sup> Oil and grease: Less than 10 mg/l as a monthly average and less than 19 mg/l on a daily basis.

Oil storage areas will be located in the Construction Camp Area, the Construction Facilities Area and initial site compound in an area of concrete hardstanding.

Bunding and containment measures will comprise as a minimum:

- Fuels/oils will be stored in a container which is of sufficient strength and structural integrity to ensure that it is unlikely to burst or leak in its ordinary use;
- Containers for hazardous liquids will be situated within a secondary containment system which satisfies the following requirements:
  - o A capacity of not less than 110% of the container's storage;
  - o Positioned so as to minimise any risk of damage by impact; and
  - o Its base and walls must be impermeable to water and oil;
- Separate bunded areas will be provided for incompatible materials and all containers will be clearly labelled with: the contents, appropriate spill response action and the location of the relevant spill response equipment;
- Bunded, contained areas will be located away from watercourses; and
- Appropriate and sufficient spill response equipment will be available for all substances stored and used on site and what types of spill require the support of offsite specialist spill response contractors.

In addition, to reduce the risk of spill and leaks from underground oil water separators and as a secondary containment for septic tanks, double wall glass reinforced plastic (GRP) will be used.

### ***Underground Tanks and Septic Tank Design***

It is planned that septic tanks will be emptied on a daily basis. However for contingency, they will be sized to contain approximately 2-3 days usage. Discharges from canteen areas, parking areas, refuelling areas and hazardous materials storage areas will flow to dedicated underground oil water separator systems. These will be sized based on the expected flowrate and in accordance with manufacturer's requirements (which will include recommended capacity including contingency). Each system will be designed such that discharges from the separator system meets the relevant oil in water standard<sup>14</sup> and residual solid and liquid waste is removed and managed appropriately.

### **Construction Measures**

A number of construction methods have been adopted specifically to minimise the potential for accidental events.

The Base Case Design includes installation of a gravity sewer which will flow from North Construction Area alongside the berm to the new SD2 sewage treatment plant. Options for installing the sewer are under consideration. Methods include installing the sewer over the existing export and distribution pipelines or using horizontal directional drilling methods to route the sewer under the pipelines. The selected option will take into account the need to minimise the potential for damage to the existing pipelines as far as possible.

In the vicinity of the existing pipelines, excavation will be completed by hand or using light weight machinery under highly controlled conditions. The location of known pipeline routes will be identified by hand digging at two locations prior to construction of the permanent works. The soil around and above pipelines will be undisturbed as a far as practicable to reduce the risk of movement of the pipelines.

---

<sup>14</sup> Oil and grease: Less than 10 mg/l as a monthly average and less than 19 mg/l on a daily basis.



## Procedures and Controls

In addition to the design and construction measures listed above, the following key procedures and controls will be implemented:

- An accurate hazardous materials inventory will be maintained and Material Safety Sheets (MSDS) will be provided in the appropriate languages (Azeri and English as a minimum). The inventory will include records of used hazardous substances and materials;
- Site drainage and pollution hazard maps will be produced showing the sources of potential pollution pathways and key receptors;
- A refuelling and hydraulic system filling procedure will be developed and implemented which details the pre-checks, level indication monitoring, provision of temporary containment and drip trays, communication, training and spill kit requirements;
- A risk assessment will be completed for any works required over live lines (including utilities) for approval before works will commence;
- Adequate training in spill response will be provided for all personnel; and
- A spills register will be maintained and submitted on a monthly basis which will include key details of all spills including remediation works, if required. The spill register will clearly identify both closed and outstanding actions, the elapsed time between opening and closing each action, and (in the case of outstanding actions) the proposed date for completion.

### 11.4.4 Spill Response

#### Contractor's Spill Response

A spill response plan will be prepared prior to commencing work on the SD2 Infrastructure Project. This document will be aligned with BP's Oil Spill Response Plans (OSRP) and integrate with those plans maintained by the 3<sup>rd</sup> party pipeline owners that operate those pipelines over which crossings will be installed.

#### BP's Spill Response

BP, as Operator of the SD PSA, has developed and maintains a range of Oil Spill Response Plans (OSRP) for its offshore and onshore operations in Azerbaijan. These Plans encompass all phases for SD development and establish the notification, response and follow-up actions that must be implemented should an accidental event occur. The relevant OSRP Plans will be expanded to include the SD2 Infrastructure Project and those of the construction contractor that will undertake the work. The contractor will be accountable for emergency and spill response which will be aligned with BP's processes and procedures.

The Sangachal Terminal OSRP sits within the structure of the BP Incident Management System (IMS), as shown in Figure 11.6, which determines the organisational and resource requirements for all incidents, assigns roles and responsibilities, and provides detailed response procedures.

This section provides an overview of BP's systems for the operation of the Terminal. As the construction contractor has yet to be selected it provides an overview of the type of system the construction contractor will develop and implement during the works.

**Figure 11.6 BP’s Incident Management System**

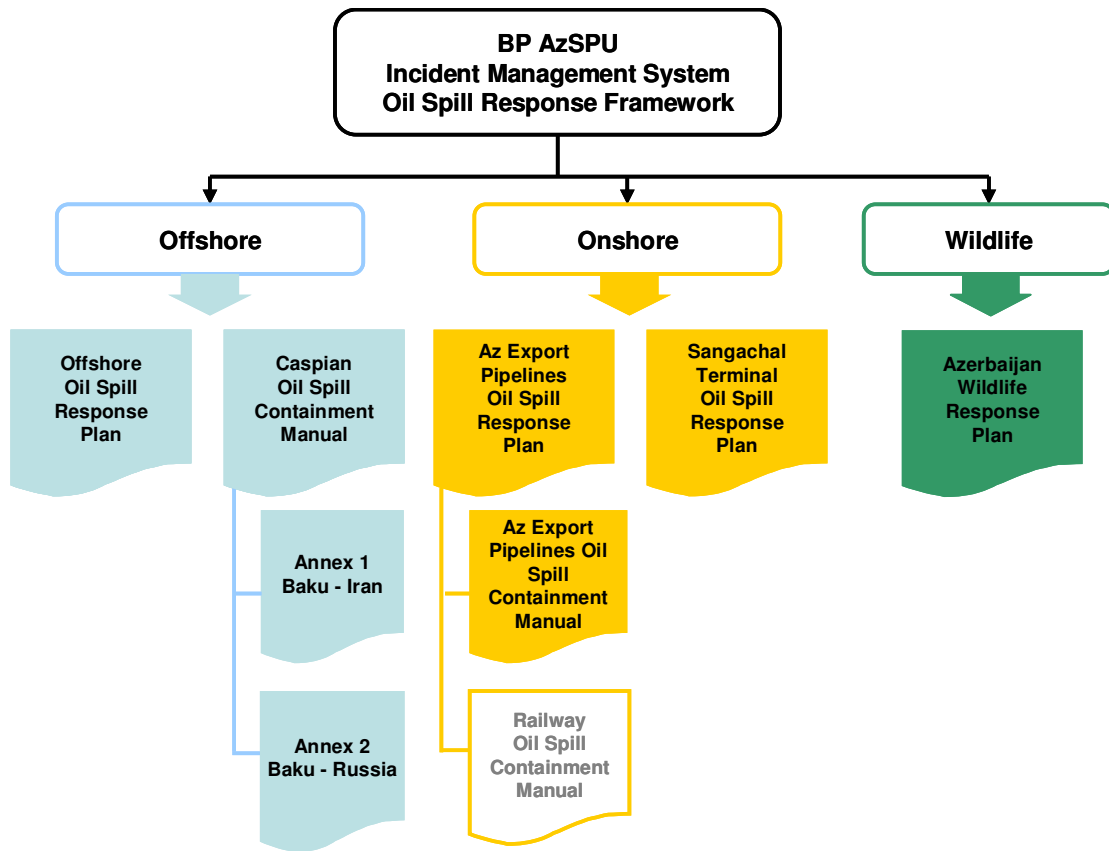

BP’s response strategy is based on:

- An in-depth risk assessment of the entire crude oil and gas condensate operations at the Terminal;
- Potential volumetric loss of containment by storage tank;
- Analysis of potential spill movement; environmental sensitivities; and
- The optimum type and location of emergency response resources.

BP supplements its dedicated resources with specialised spill response contractors. The OSRP Plans describe how BP will utilise these resources to protect the environment in which it resides.

The Terminal has adopted the internationally recognised three-tiered approach for classification of oil spills in the design of its oil spill response capability as summarised in Table 11.1.

**Table 11.1 Oil Spill Response Tiers**

<b>Tier 1 (Minor Event)</b>	Involves those incidents which can be handled by onsite personnel and equipment. The Site Response Teams (SRTs) may be activated; spill response equipment deployed and the possible notification of the Incident Management Team (IMT) depending on the situation.
<b>Tier 2 (Major Event)</b>	Operational oil spill, which may involve injury or environmental damage and which may require additional resources and manpower, media coverage or significant resources that may not be available at the facility. The SRTs and IMT will be activated, The SPU Leader will be notified and the Business Support Team (BST) may also be activated.
<b>Tier 3 (Crisis)</b>	Major oil spill that involves fatality, significant environmental damage, or requires assistance from outside Azerbaijan and is likely to impact the community for an extended period. May arouse national or international media interest. The SRT, IMT and BST will be activated and the BP Group HSE Vice President will be notified.

The Sangachal Terminal OSRP covers the Terminal operating area and associated properties, the including the area of land between the Baku-Salyan Highway and the Terminal. The Terminal has in place trained and 24 hour available Site Response Teams (SRTs), dedicated and pre-positioned spill response equipment throughout the Terminal and additional support services pre-identified.

The OSRP defines a precise sequence of actions following an incident, with formal assignment of responsibility as indicated in Figure 11.7. BP maintains contracts with a number of specialist oil spill response contractors, who are equipped to provide 24-hour availability of containment and recovery services, and whose actions are controlled by the BP Incident Management Team On-Scene Commander.

**Figure 11.7 Site Emergency Response Organisation**

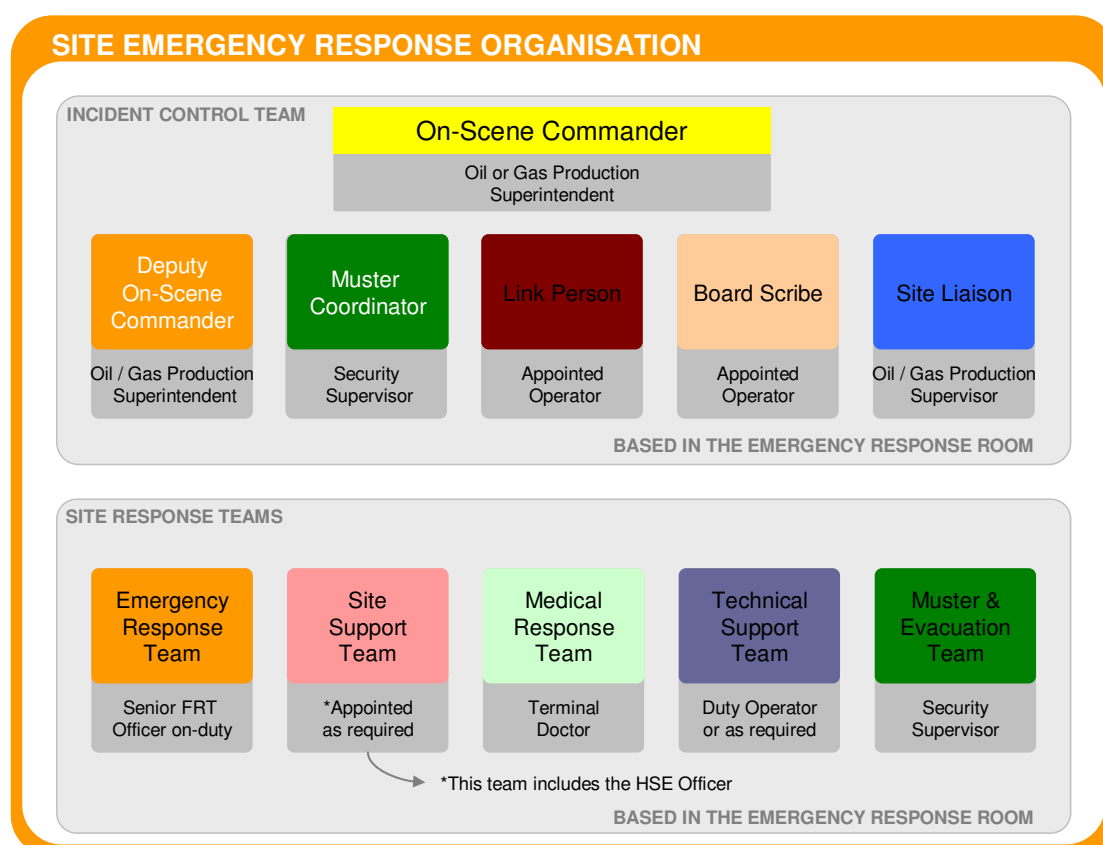

### 11.4.5 Spill Reporting

All non-approved releases (liquids, gases or solids) including releases exceeding approved limits or specified conditions will be internally reported and investigated.

The internal reporting requirements include the following:

- All spills of 1 litre or more will be reported and spills of less than 1 litre will be deemed reportable if an immediate response is required to prevent further losses, damage to the environment or safety hazards to personnel<sup>15</sup>;
- If a spill results in the release of material from secondary containment and results in contamination of soil, ground or surface water, an investigation will be commenced to

<sup>15</sup> Where the status of the spill is unclear (i.e. the nature, type or volume of an unplanned substance loss) the HSE representative will sought for clarification.

determine the extent of contamination and necessary clean-up operations to ensure decontamination is successful; and

- A report will be prepared in accordance with the requirements below:
  - Initial incident notification report within 24 hours:
    - Time & date of incident;
    - Incident Description;
    - Description and properties of substance spilt;
    - Estimated volume;
    - Immediate actions taken; and
    - Corrective/preventative actions.

External notification requirements agreed with the MENR are:

- For liquid releases to the environment exceeding a volume of 50L, notification will be made within 24 hours after the incident verbally and within 72 hours in the written form; and
- If the release to the environment is less than 50L, then information about the release will be included into the BP AGT Region Report on Unplanned Releases and sent to the MENR on a monthly basis.



## 12 Environmental and Social Management

### Contents

12.1	Introduction.....	2
12.2	Contractor Selection.....	2
12.3	Contractor’s Management System.....	2
	12.3.1 Approach.....	2
	12.3.2 HSSE Management System Requirements.....	3
12.4	Waste Management .....	5
	12.4.1 Waste Management Processes and Procedures .....	5
	12.4.2 Waste Segregation and Transfer .....	5
12.5	Environmental Monitoring.....	6

### List of Figures

Figure 12.1	Roles and Responsibilities of the Contractor and BP .....	3
-------------	---	---

### List of Tables

Table 12.1	Key Requirements of the Contractors HSSE Management System .....	3
------------	--	---

## 12.1 Introduction

Under the Shah Deniz Production Sharing Agreement (PSA), BP as the Operator is responsible for the environmental and social management of the Shah Deniz (SD) activities, to ensure that project commitments are implemented, and that the project's performance complies with applicable environmental and social legal, regulatory and corporate requirements.

This Chapter provides an overview of the systems that will be used to manage the environmental and social issues associated with SD2 Infrastructure Project.

## 12.2 Contractor Selection

The SD2 Infrastructure works will be performed by key contractors, appointed by BP. A rigorous contractor selection process will be in place to ensure that key contractors used during the SD2 Infrastructure Project have effective HSSE Management Systems that align with BP expectations.

Companies invited to tender for contracts will be provided with detailed information on BP and AGT Region environmental and social expectations and standards. The environmental and social capability of the companies and their ability to comply with the expectations and standards will be an element in tender evaluation and award. Companies will be required to present detailed proposals for establishing and operating a compliant HSSE Management System throughout the duration of their contracts.

## 12.3 Contractor's Management System

### 12.3.1 Approach

The appointed contractor(s) will be required to develop, implement and monitor environment and social requirements through the HSSE Management System. These requirements will be drawn from relevant HSSE contract clauses, developed to ensure that the commitments of the ESIA are implemented and managed throughout the SD2 Infrastructure Project.

The HSSE Management System will be enforced through a HSSE Plan which will be reviewed by the SD2 Infrastructure Project Team prior to implementation and regularly updated. The HSSE Plan will cover:

- Leadership and Commitment;
- Legislative Compliance;
- Training, Competency and Behaviours;
- Control of Work;
- Risk Management;
- Working with Machinery;
- Management of Change;
- Occupational Health and Hygiene;
- Industrial Hygiene;
- Security management;
- Incident Notification, Investigation and Reporting;
- Emergency Response and Crisis Management;
- HSSE reporting; and
- Assurance and Audit.

Both the contractor and BP will be responsible for waste management, with the BP's focus related to disposal and overall management. Figure 12.1 sets the roles and responsibilities of the contractor and BP. Section 12.4 provides further details on the waste management responsibilities of BP.

**Figure 12.1 Roles and Responsibilities of the Contractor and BP**

Contractor	BP
<p><b>Waste Management</b></p> <ul style="list-style-type: none"> <li>• Implement waste management contract clause requirements;</li> <li>• Segregate waste as per BP requirements detailed within the contract clauses;</li> <li>• Deliver skips to CWAA;</li> <li>• Ensure Waste Transfer Notes (WTNs) accompany all waste transfers;</li> <li>• Minimise waste; and</li> <li>• Develop and maintain waste management and minimisation.</li> </ul>	<p><b>Waste Management</b></p> <ul style="list-style-type: none"> <li>• Ensure Contractor adopt contract clause requirements and ESIA commitments implemented and deviations managed;</li> <li>• Lead interface between AGT Region waste operations team and Contractor;</li> <li>• Responsible for the provision of waste handling, storage, collection and disposal; and</li> <li>• Providing separate containers for different waste types.</li> </ul>
<p><b>Environmental and Social Management</b></p> <ul style="list-style-type: none"> <li>• Implementation of environmental and social contract clause requirements.</li> </ul>	<p><b>Environmental and Social Management</b></p> <ul style="list-style-type: none"> <li>• Ensure Contractors adopt contract clause requirements and ESIA commitments implemented and deviations managed via the management of change process;</li> <li>• Implement assurance program to influence Contractors environmental and social performance;</li> <li>• Lead interface with Contractor;</li> <li>• Management and implementation of IEMP.</li> </ul>

The Contractor will be required to ensure that all subcontractors comply with the HSSE Plan.

### 12.3.2 HSSE Management System Requirements

An overview of the key environmental and social requirements to be implemented in the Contractor's HSSE Management System is provided in Table 12.1.

**Table 12.1 Key Requirements of the Contractors HSSE Management System**

Topic	Key Requirements
<b>Environmental</b>	
Environmental Management	<ul style="list-style-type: none"> <li>• Contractors will prepare and implement an environmental management plan which is consistent with the requirements of ISO 14001 and includes the following support procedures and plans: <ul style="list-style-type: none"> <li>• Environmental Aspects and Impacts Identification, Targets and Objectives Plan;</li> <li>• Development and maintenance of a Legislation Register;</li> <li>• Waste Management Plan;</li> <li>• Waste Minimisation and Green Procurement Plan;</li> <li>• Pollution Prevention and Spill Response Plan;</li> <li>• Nuisance Management Plan;</li> <li>• Wildlife Management Plan;</li> <li>• Archaeology and Cultural Heritage Management Plan; and</li> <li>• Spoil, Surface Water and Landscape Management Plan.</li> </ul> </li> </ul>
Waste Management	<ul style="list-style-type: none"> <li>• Contractors will identify and manage waste in accordance with the following core principles: <ul style="list-style-type: none"> <li>• Waste management planning;</li> <li>• Waste minimisation;</li> <li>• Waste register and classification;</li> <li>• Waste segregation and storage; and</li> <li>• Waste awareness and training.</li> </ul> </li> </ul> <p>Contractors will submit a Waste Management and Minimisation Plan for BP approval prior to contract commencement.</p>
Nuisance Management	<ul style="list-style-type: none"> <li>• A Nuisance Management Plan will be prepared and implemented that details the processes used to prevent nuisance associated with construction noise, light from construction work areas, odours, pests and vermin.</li> </ul> <p>The plan will include details of the site controls used to manage and monitor nuisance issues.</p>

Topic	Key Requirements
Pollution Prevention	<ul style="list-style-type: none"> <li>A Pollution Prevention and Control Plan will be prepared and will include the following:               <ul style="list-style-type: none"> <li>A register of the nature, location and quantities of all ozone depleting chemicals on site.</li> <li>A management strategy focused on minimising the environmental impact as a result of using chemicals, through the correct selection, transportation, storage, deployment and disposal.</li> <li>A Hazardous Materials Inventory that will record all use of hazardous substances and materials.</li> <li>Identification of potential planned discharges prior to mobilisation.</li> </ul> </li> </ul>
Wildlife Management	<ul style="list-style-type: none"> <li>A Wildlife Management Plan will be prepared and implemented which defines the activities and actions to be taken to minimise the impact to local wildlife and habitats during the works.</li> <li>The plan shall include procedures for inspecting vegetation for wildlife prior to removal, actions to be taken should wildlife be encountered and reporting requirements.</li> </ul>
Archaeology and Cultural Heritage Management	<ul style="list-style-type: none"> <li>An Archaeology and Cultural Heritage Management Plan will be developed and implemented, detailing how the works will be managed in relation to potential archaeological cultural heritage impacts to include:               <ul style="list-style-type: none"> <li>Known archaeological resources within the site, including location, significance, and protective buffers;</li> <li>Watching brief procedure to be followed during ground breaking activities;</li> <li>Archaeological chance finds procedure including reporting requirements and procedure for notifying BP; and</li> <li>Contractors training requirements.</li> </ul> </li> <li>The Archaeology and Cultural Heritage Management Plan will be updated to include details of finds and any corrective actions.</li> </ul>
Spoil, Surface Water and Landscape Management	<ul style="list-style-type: none"> <li>A Spoil and Landscape Management Plan will be prepared and implemented, detailing the following:               <ul style="list-style-type: none"> <li>The estimated amount of spoil to be generated on site;</li> <li>The estimated amount of spoil suitable for re-use on site;</li> <li>Amount and destination of unused spoil (including locations of any spoil heaps);</li> <li>The contaminative potential of the spoil generated onsite and control actions to prevent pollution;</li> <li>Dust management;</li> <li>Schedule of spoil activities; and</li> <li>Biorestitution Plan.</li> </ul> </li> </ul>
Spill Response, Notification and Close Out Actions	<ul style="list-style-type: none"> <li>Contractors will prepare and implement a Spill Response Plan and Notification Plan.</li> </ul>
Traffic and Transportation	<ul style="list-style-type: none"> <li>Contractors will develop a Traffic Management Plan to effectively manage vehicles and pedestrians on site.</li> <li>Contractors will implement a Transportation Plan which will cover all forms of transport both onsite and offsite in Azerbaijan. The Transportation Plan shall will cover, as a minimum, the following:               <ul style="list-style-type: none"> <li>Scope of work to be performed by Transport department;</li> <li>Overview of Transport Organisation;</li> <li>Roles and Responsibilities;</li> <li>How vehicle will be sourced and minimum standard;</li> <li>Inspection and Maintenance Systems;</li> <li>Vehicle Operations; and</li> <li>Drivers.</li> </ul> </li> </ul>
<b>Social</b>	
Community Interaction and Social Impact Management	<ul style="list-style-type: none"> <li>Contractors will prepare and implement a Community Interaction and Social Impact Management Plan, detailing how construction workers will be managed in relation to potential social impacts and how interactions with the adjacent communities will be managed. This Plan should include:               <ul style="list-style-type: none"> <li>Roles and responsibilities associated with liaising and interacting with the community; and</li> <li>Grievance mechanisms for dealing with community complaints.</li> </ul> </li> <li>A Community Health Plan will be developed and implemented to address and monitor community health risks associated with the infrastructure construction work.</li> </ul>
Workforce Welfare and Local Employment	<ul style="list-style-type: none"> <li>Contractors will prepare and implement a Workforce Welfare and Local Employment Plan for the works, detailing the following:               <ul style="list-style-type: none"> <li>Azerbaijani content development strategy to include well-planned nationalisation agenda and local content inclusion through continuous search of local market, engagement of local suppliers and priority given by the organisation to local content;</li> <li>Detailed description of the proposed approach to developing Azerbaijani capabilities in the tendered services;</li> <li>Estimation of the percentage of compensation associated with the proposed services that ultimately stay in Azerbaijan;</li> <li>Detailed description of Azerbaijani content factor within organisation;</li> <li>Proportion of men and women staff proposed;</li> <li>Process for de-manning of the workforce at the end of the construction phase;</li> <li>Potential market distortion due to temporary inputs to local economy;</li> <li>Recruitment procedures; and</li> <li>Grievance mechanisms for dealing with worker complaints.</li> </ul> </li> </ul>

## 12.4 Waste Management

Waste generated during the SD2 Infrastructure Project will be managed in accordance with the existing BP AGT Region management plans and procedures. All wastes generated as part of the SD2 Infrastructure Project will be identified and managed in accordance with the following requirements:

- Site specific Waste Management Plans will be prepared;
- Waste minimisation;
- All waste streams identified and classified;
- Waste segregation at source;
- Workforce awareness and training;
- AGT Region Approved Waste Contractors List;
- AGT Region Waste Streams Register; and
- AGT Region Waste Management Strategy.

In accordance with internationally recognised best practice, the waste hierarchy, coupled with the AGT Region Best Practicable Environmental Option (BPEO) assessment of available waste disposal / treatment technologies that has been conducted, the AGT Region Waste Management Strategy and supporting documentation will be adopted as the basis for guiding waste management decisions. This approach is intended to ensure that wastes are managed in the most sustainable way and in compliance with all applicable AGT Region standards and national legislation whilst ensuring they are recovered or disposed of efficiently without endangering human health and minimising environmental and social impacts.

### 12.4.1 Waste Management Processes and Procedures

Waste Management and Minimisation Plans will be developed and maintained to cover the duration of the SD2 Infrastructure Project's activities to match the anticipated waste streams, likely quantities and any special handling requirements.

A schedule of internal audits will be developed to objectively monitor the performance of the waste management systems during the SD2 Infrastructure Project's activities and to ensure that all corrective actions and improvements are identified and implemented.

To support the Waste Management Plan, contractors will receive waste management training covering:

- Identification of waste types and potential associated hazards;
- Waste segregation; and
- Waste transfer documentation (if involved in waste movement).

All new waste disposal routes are routinely assessed prior to use and must be compliant with applicable local laws and regulations. Waste will only be routed to those waste disposal facilities that have been approved for use by the AGT Region.

### 12.4.2 Waste Segregation and Transfer

Waste streams will be segregated at source to permit reuse/recycling and to avoid contact between incompatible materials. The segregation requirements will be clearly indicated by the use of containers with clear signage denoting the waste types that are suitable for the containers provided.

All waste transfers will be accompanied by individual Waste Transfer Notes (WTNs), confirming the waste type, quantity, waste generator, consignee, consignor (if different from the generator) and, in the case of hazardous wastes, both Waste Passports and, where required, MSDS documentation. A final visual inspection of all waste consignments will be made prior to transfer note sign-off and uplift. Coloured copies of the waste transfer documentation together with other relevant information e.g. MSDS, Waste Passports, will be

retained by the waste generator. All parties involved in transporting wastes will retain a copy of the waste transfer note.

Depending upon the nature of the waste and the approved method of recycling/disposal, wastes may be routed via the Central Waste Accumulation Area (CWAA), waste transfer station or similar facility, or alternatively may be routed directly to their final approved destination.

## **12.5 Environmental Monitoring**

BP's AGT Region has implemented an Integrated Environmental Monitoring Programme (IEMP) designed to provide a consistent, long-term set of data, with the objective of ensuring an accurate picture of potential impacts of AGT Region activities on the surrounding environment so that they can be managed and mitigated as effectively as possible. The SD2 Infrastructure Project will be integrated into this programme.

Onshore monitoring undertaken as part of the IEMP includes:

- Baseline surveys – provide a general understanding of the physical, chemical and ecological parameters at a particular location before development commences. Any unusual or sensitive ecological features, which might affect the design of a development, can also be identified; and
- Routine environmental monitoring surveys – provide an assessment of the impact of AGT Region operations, aiding responsible environmental management.

The existing IEMP will be supplemented by construction focused monitoring that will include:

- Noise;
- Dust;
- Wetland water quality; and
- Air quality.

This monitoring will be integrated into the construction phase Environmental and Social Mitigation and Monitoring Plan (ESMMP).

## 13 Residual Impacts and Conclusion

### Contents

13.1	Introduction.....	2
13.2	Environmental Impacts.....	2
13.3	Socio-Economic Impacts.....	5
13.4	Cumulative, Transboundary and Accidental Events .....	8
13.5	Environmental and Social Management .....	9
13.6	Conclusions.....	10

### List of Tables

Table 13.1	Summary of Residual Environmental Impacts .....	2
Table 13.2	Summary of Residual Social-Economic Impacts .....	6



## 13.1 Introduction

This section summarises the residual environmental and socio-economic impacts and conclusions of the Shah Deniz 2 (SD2) Infrastructure Project ESIA.

## 13.2 Environmental Impacts

Environmental impacts have been assessed for SD2 Infrastructure Project and Table 13.1 provides a summary of the residual impacts.

**Table 13.1 Summary of Residual Environmental Impacts**

	Event	Event Magnitude	Receptor Sensitivity	Impact Significance
Atmosphere	Emissions from onsite and offsite construction plant and vehicles.	Medium	(Humans) Medium	Moderate Negative
	Emissions from surface soil layer removal and spoil movement.			
Noise	Noise emissions associated with construction activities.	Medium	(Humans) Medium (Biological/Ecological) Medium	Moderate Negative
Impact to the Terrestrial and Coastal Environment (Ecology)	Surface soil layer removal and spoil movement, drainage management works and Pipeline Landfall Area preparation.	Medium	(Biological/Ecological) Medium	Moderate Negative
Impact to the Terrestrial Environment (Soil, Groundwater and Surface Water)	Excavation works and ground disturbance	Medium	(Soil) Medium	Moderate Negative
			(Surface Water) Medium	Moderate Negative
Impact to the Terrestrial and Coastal Environment (Cultural Heritage)	Impacts to cultural heritage due to earthworks and piling.	Medium	(Physical Receptors) Medium	Moderate Negative

### Air Quality and Dust

Emissions from onsite plant and vehicles and offsite vehicles will be generated within the vicinity of the Terminal and disperse into the atmosphere. The combined impact to air quality (specifically the contribution to NO<sub>2</sub> concentrations) from these sources at sensitive receptors (i.e. Sangachal Town, Umid, Azim Kend and Masiv 3) is considered to be of no more than a moderate negative impact.

The generation of dust and PM<sub>10</sub> from surface soil layer removal and spoil movement activities has been modelled. Modelling of long term (annual average) and short term (24 hour) PM<sub>10</sub> concentrations at ground level concluded that the expected increase at sensitive receptors would be no more than 12% (under worst case conditions) of the relevant short term PM<sub>10</sub> limit value of 50 µg/m<sup>3</sup>, and this increase would be imperceptible when compared to existing PM<sub>10</sub> concentrations at Sangachal Town (109 µg/m<sup>3</sup>). The maximum daily dust deposition rate was calculated as 132 mg/m<sup>2</sup>/day at Sangachal Town. This is comparable to

the guidance value of  $133 \text{ mg/m}^2/\text{day}^1$ . Existing measures to control dust include limiting vehicle speeds on unsurfaced roads, use of water to control dust from exposed surfaces and suspension of work should excessive dust levels arise. It is expected that, in general, the dust generated by the construction works will be imperceptible in the context of the existing, background levels of dust deposition that generally occur in semi-arid areas (estimated to be between  $495\text{-}896 \text{ mg/m}^2/\text{s}^2$ ).

## Noise

Noise modelling has been undertaken to estimate the increase in noise levels at sensitive receptors in the Terminal vicinity from onsite plant and vehicles. Modelling was based on a realistic scenario which reflects the expected typical construction activities (i.e. 50% of the plant and vehicles are operating at the works boundary and 50% within the centre of the SD2 Infrastructure area).

The results of the noise modelling showed that no exceedances are predicted at Azim Kend, Masiv 3, Umid or Sangachal Town. Highest noise levels were predicted at Sangachal Town, where the noise limit value of 65dB is predicted to be just met. The noise level predicted, however, was lower than the existing average ambient noise level of 67dB(A). This implies that construction noise would not be significantly noticeable in the context of existing noise levels.

An assessment was also undertaken to determine the likely worst case impacts should all project activities that contribute to construction noise (including concrete breaking and the piling activities) coincide with the period of highest onsite construction plant and vehicle activity. It was concluded that under this worst case scenario, the limit value of 65 dB(A) would be met at Azim Kend and Umid, but exceeded at Sangachal Town. At this receptor, however, it is predicted that the worst case noise level would be comparable to the existing ambient noise level of 67 dB(A), implying that construction noise would not be significantly noticeable in the context of the existing noise levels in this location.

Existing control measures to mitigate noise impacts include switching off construction plant and vehicles whilst not in use, and the requirement for all onsite construction plant and vehicles to be fitted with effective exhaust silencers. In addition, the following mitigation measures will be implemented:

- Where practicable, portable acoustic screens will be used around pneumatic hammers when undertaking concrete breaking; and
- The local communities will be informed of the proposed schedule and works prior to commencement of the trial piling activities with driven piles.

Overall, it was concluded that the noise impact to both humans and biological/ecological receptors would be a moderate negative impact.

## Terrestrial and Coastal Ecology

It is estimated that the SD2 Infrastructure works associated with removal of the surface soil layer removal, spoil movement, drainage management works and preparation works at the Pipeline Landfall Area will result in the removal of approximately 85 hectares of existing habitat. The loss will be permanent within approximately 50% of the affected area. The remaining areas will be in temporary use and subsequently reinstated.

Local vegetation in the vicinity of the SD2 Infrastructure area is characterised by floral species which are typical for the area surrounding the Terminal and are neither rare nor threatened. Surveys have shown no significant change in the distribution or status of desert/semi-desert vegetation over time.

<sup>1</sup> Most stringent guidance levels of  $133 \text{ }\mu\text{g/m}^2/\text{day}$  were used sourced from Australian guidance. No single international value exists.

<sup>2</sup> Wanquan Ta and Tao Wang (2004); 'Measurements of dust deposition in arid and semi-arid regions, China', American Society of Civil Engineers (ASCE) pp. 1-10.

The wetland area to the south of the Terminal, where wadi clearance works are planned, is dependant primarily on seasonal water flow through the wadi system. However, surveys have shown no significant change in species present or the overall extent of the wetland, other than as a result of 3<sup>rd</sup> party construction activities. The wetland habitat is not considered to be unique and the area affected by the works is not critical to the function of the habitat as a whole.

Approximately 12% of the bird species recorded in Terminal vicinity are ground nesting birds. However, there is no evidence within the surveys completed to date to indicate that the habitat within the SD2 Infrastructure area is of unique value to breeding birds. It is considered likely that birds within the Terminal vicinity are already habituated to noise from industrial and road traffic noise.

Six faunal species (including four with conservation status<sup>3</sup>) have been recorded in low numbers in the Terminal vicinity. Only the spur thighed tortoise (*Testudo graeca*) has been recorded consistently. The area affected by the works is not optimal habitat and not considered critical to the existing population. The works would contribute to no more than a minor temporary change and ecological functionality of the faunal species populations will be maintained.

Impacts will be minimised as far as practicable and necessary through the implementation of the existing control measures, which include a requirement to:

- Inspect vegetation prior to removal to detect presence of wildlife and cease activities until appropriate action is taken to ensure any wildlife encountered is not harmed;
- Minimise surface soil layer removal and vegetation clearance near to wetlands, rivers or stream banks; and
- Undertake daily checks of excavations for wildlife prior to work commencing.

A Wildlife Management Plan will be prepared and implemented, which defines the activities and actions to be taken to minimise the impact to local wildlife and habitats during the works including planned relocation of any mammals, reptiles or any IUCN or Azerbaijan Red Data Book listed species encountered within the areas affected by the SD2 Infrastructure works.

The assessment concluded that the SD2 Infrastructure works will result in a no more than moderate adverse impact to ecological receptors.

### **Soil, Groundwater and Surface Water**

The surface soil layer removal and spoil movement and drainage management works may result in mobilisation of existing soil, groundwater and surface water contamination through physical disturbance. Monitoring to date has not indicated any significant or widespread contamination in the areas where infrastructure works are planned, but it is possible that localised areas of contamination exist.

Within the wetland area, including the areas where wadi clearance works are planned, surveys have indicated high levels of Total Hydrocarbon Content (THC), Polyaromatic Hydrocarbons (PAH) and cadmium (within groundwater samples) and phenols (in soil). In addition, localised hydrocarbon spills were observed during a walkover in June 2011.

Where oily contaminated soil, ground water, surface water or other materials outside of the existing Sangachal Terminal property boundary are encountered and require handling, these materials will be relocated to areas of comparable environmental quality and function and the characteristics of the materials recorded. If contaminated materials are encountered within the existing Sangachal Terminal property boundary, these will be classified and managed as waste in accordance with existing BP waste management procedures. Other control measures to minimise potential mobilisation of contamination include locating spoil piles away from watercourses, and maintaining site drainage and pollution hazards maps that show

<sup>3</sup> Including IUCN Lower Risk/Near Threatened, IUCN Vulnerable and Azerbaijan Red Data Book Species.

potential sources of pollution (e.g. storage areas), pathways (e.g. drains) and receptors (e.g. the Caspian Sea).

The assessment concluded that there was a moderate negative impact on soil and surface water. It is considered that impacts to soil and surface water are minimised as far as practicable and necessary through the implementation of the existing control measures.

### **Cultural Heritage**

Surface soil layer removal and spoil movement and drainage management works has the potential to impact cultural heritage. No state protected monuments or other type of cultural heritage sites are known to occur within the upper 0.15m of topsoil, or under existing stockpiles. Areas beneath existing spoil heaps are likely to have been substantially impacted as a result of previous construction works, and the Pipeline Landfall Area has also been previously disturbed by aggregate and/or limestone quarrying. Existing controls include a watching brief to identify any artefacts or sites of archaeological importance and a chance-finds procedure. An archaeological baseline survey, undertaken in 4Q 2011 (results pending), will inform the Archaeology and Cultural Heritage Management Plan, further reducing the potential for damage to cultural heritage sites.

Piling activities are planned to include driven pile trials in the SD2 Expansion Area and bored piles at the pipeline crossings. Piling activities, especially driven piles, can generate vibrations within soil and rock matrices that have the potential to impact cultural heritage structures, such as the Caravanserai. The driven piles trials are planned to be located west of the SD2 Expansion Area more than 1km from the Caravanserai. The areas where the bored pipeline crossings are planned are located a minimum of 250m from the Caravanserai. As vibrations from piling activities are not expected to travel more than 50m from the source it is considered unlikely that the Caravanserai would be affected by piling activities.

Overall, the impact to cultural heritage from the earthworks and piling is considered to have a moderate negative impact.

### **13.3 Socio-Economic Impacts**

Socio-economic impacts have been assessed for SD2 Infrastructure Project and Table 13.2 provides a summary of the residual impacts.

**Table 13.2 Summary of Residual Socio-Economic Impacts**

Event	Magnitude		Probability	Receptor Sensitivity	Significance
	Spatial Scope	Timing and Duration			
<b>Direct Impacts</b>					
Disruption and access restrictions (SD2 Infrastructure Area)	Local	All SD2 Infrastructure area will be temporarily fenced during works to prevent unauthorised access.	Highly likely	Local herders – High	<b>Moderate – major negative</b>
		Temporary impact			
		Up to approximately 115 hectares will be permanently removed from use for herders.			
Disruption and access restrictions (Pipeline Landfall Area)	Local	The majority of the SD2 Infrastructure Area will be temporarily fenced during works (between March 2012 and June 2013).  Temporary impact	Highly likely	Recreational fishermen - Low	<b>Negligible</b>
			Highly likely	Commercial fishermen - Medium	<b>Negative</b>
			Highly likely	Recreational users - Low	<b>Negligible</b>
			Unlikely	Shoreline property values - Low	<b>Negligible</b>
Employment creation	Local	Employment will occur throughout the project, and is expected to peak between April 2012 and November 2012.	Highly likely	Local community - High	<b>Moderate-Major Positive</b>
	Regional	Temporary impact	Likely	Regional community – Medium	<b>Positive</b>
Training and skills development	Local	Training will commence prior to the project activities and continue throughout the project.	Highly likely	Local community – High	<b>Moderate-Major positive</b>
	Regional	Permanent	Highly likely	Local community – Medium	<b>Positive</b>
Procurement of goods and services	Local and Regional	Procurement will take place throughout the project and benefits will cease shortly after the project finishes.	Highly likely	Local and regional businesses - High	<b>Moderate-Major positive</b>
	National	Temporary		National businesses - High	<b>Positive</b>
Disruption and impact to community safety associated with construction vehicle movements (offsite)	Local	Off site traffic movements will take place throughout the project.  Temporary	Unlikely	Road users and local community – High	<b>Negative</b>
Deterioration in Road Conditions	Local	Changes to road condition from the transportation of construction materials will take place throughout the project and will cease after the project finishes.  Temporary	Highly unlikely	Local Roads – High Main highway - Low	<b>Negligible</b>
Road and rail works	Local, and regional	Road and rail works are expected throughout the project but disruption is expected to be of short duration.  Temporary	Highly likely	Local, regional and national businesses – High	<b>Negative</b>
De-manning	Local	De-manning will likely commence prior to end of the project as manning levels decrease however it is expected that the main SD2 Project will provide relevant employment opportunities for workers.  Permanent	Unlikely	Local community – High	<b>Negligible</b>

### **Disruption and Access Restriction**

Project activities associated with establishment of the initial site compound at the commencement of the works, to closure of the EOP Road and At-Grade Railway Crossing, during the final stages will all involve changes to land access within the footprint of the SD2 Infrastructure Area. While it is not intended to permanently fence the entire perimeter of the SD2 Infrastructure Area, it will be necessary to fence each area temporarily during construction works for safety and security reasons.

The sensitivity of recreational fishermen, recreational users and shoreline properties is considered to be low; impacts are considered to be minimised as far as practicable and necessary and no mitigation is required. Overall, the impact to herders is considered to be moderate to major negative and the impact to commercial fishermen negative.

### **Employment Creation**

It is anticipated that the project will employ between 450 and 700 people over the duration of the works. A Workforce Welfare and Local Employment Plan will be prepared and implemented with the aim of maximising the employment opportunities for the four local communities. It is considered that local and regional impacts associated with employment are maximised as far as practicable through existing controls. A moderate-major positive impact on a local scale is anticipated as a result of the project, specifically within the local communities.

### **Training and Skills Development**

A Training Plan will also be put in place which sets out training programmes similar to those that were implemented for the previous ACG and SD projects. The aim of the Training Plan will be to provide training and skill development opportunities with particular emphasis on the training of Azerbaijani citizens. A formal system of competency assurance will be implemented and records will be maintained of competency testing and training undertaken. Based on this, it is considered that the SD2 Infrastructure Project will have moderate to major positive impact on a local scale on training and skills development, specifically within the four local communities.

### **Procurement of Goods and Services**

The procurement of materials, equipment, goods and services will commence prior to the commencement of project activities and will continue throughout the project. The anticipated benefit to businesses cannot be quantified at present as the procurement strategy and award of construction contracts has not been made. However, preference will be given to source equipment (such as plant and construction vehicles) and materials (such as gravel) which meet the required project specifications from Azerbaijan wherever possible. This is considered to have a moderate to major positive impact at a local and regional level and a positive impact at a national level.

### **Disruption Due to Construction Vehicle Movements**

The contribution of project vehicle movements to the existing daily flows on the Baku-Salyan Highway is expected to peak at 162 (between May 2012 and October 2012). Existing controls to minimise traffic impacts include the implementation of a Transportation and Traffic Management Plan. The focus of the Plan will be to ensure that drivers and their vehicles are safe when on the road and adopt safe driving behaviours. To further minimise potential impacts to local communities associated with offsite traffic movements, it will be necessary to communicate the potential hazards associated with offsite traffic movements, as part of ongoing community liaison. It is considered that the SD2 Infrastructure Project will have a negative impact on existing traffic flows.

## Road Conditions

It is expected that the Baku-Salyan Highway will be the primary route that is used for the transport of construction materials. However, the exact transport routes used will not be determined until the procurement strategy is in place and the construction contract has been awarded. Prior to and following the SD2 Infrastructure works, it is planned to complete a survey of local roads used to transport construction materials to assess their existing condition. Any changes to the condition of local roads associated with the project will be identified and repairs made to restore their condition. Construction traffic will have no effect on the future condition of the main highway and therefore the impact is considered to be negligible to both local roads and the Highway.

## Road and Rail Works

It is anticipated that disruption to road and railway users are likely to occur as a result of road and rail works including potential temporary closures and diversions. Procedures will be established to manage any road closures requirements and/or disruption to the rail services to include duration, timings and options considered to minimise disruption. The Azerbaijan Ministry of Transport and the emergency services will be notified in advance of road closures. Activities that may affect the railway and associated timings will be agreed with the Azerbaijan rail authority. It is considered that the disruption to road and railway users will be negative.

## Demanning

As activity reduces towards the end of the project, workforce levels will reduce. However, it is understood that the works associated with the main SD2 Project will begin immediately following the completion of the SD2 Infrastructure Project. The SD2 Project will provide further opportunities for employment and therefore the probability of impacts associated with de-manning are considered to be negligible.

## 13.4 Cumulative, Transboundary and Accidental Events

Cumulative impacts, potential transboundary impacts and the impacts of accidental events associated with the SD2 Infrastructure Project have been assessed.

The potential for interaction between the different SD2 Infrastructure Project related residual impacts, resulting in a cumulative impact has been considered. The cumulative effect of all expected project activities will be managed through the implementation of a Nuisance Management Plan. The Plan will detail the processes used to prevent nuisance associated with construction noise, light from construction work areas, odours, pests and vermin. In addition a Community Interaction and Social Impact Management Plan will be implemented and maintained as a mechanism of communicating with the community and responding to community grievances.

Given the existing control measures in place, it is considered that the appropriate measures are in place to mitigate and manage potential cumulative effects between project related residual impacts.

Based on a review of available information, it is understood that the following projects (which have the potential to interact with the impacts of the SD2 Infrastructure Project based on their location and scale) are planned or under construction in the vicinity of the Terminal:

- **Qizildas Cement Plant** – To be located approximately 4km north of the Terminal;
- **Garadagh Dry Kiln Upgrade Project** – Upgrade to the existing Garadagh cement works (approximately 6km to the east) to install dry kiln technology and increase production; and
- **New Highway Junction** – Planned immediately to the south of the Terminal and planned to connect to the new Terminal access road, which forms part of the SD2 Infrastructure works.



The assessment of cumulative impacts demonstrated that negative cumulative impacts associated with the SD2 Infrastructure Project and other projects in the Terminal vicinity planned or under construction are expected to be limited.

The aspect with the greatest potential for negative impact is traffic disruption, assuming that the SD2 Infrastructure Project and the Qizildas Cement Plant construction schedules overlap. There is also potential for cumulative noise impacts at sensitive receptors associated with the SD2 Infrastructure Project and the Highway Junction. It will therefore, be necessary for the construction contractors and the Highways Authority to liaise to ensure these impacts are minimised through scheduling of works and use of appropriate mitigation measures.

There are also a number of significant positive cumulative impacts, primarily associated with employment and economic flows.

Accidental events are considered separately from routine and non-routine activities as they only arise as a result of a technical failure, human error or as a result of natural phenomena such as a seismic event.

Potential accidental events associated with the SD2 Infrastructure Project works include:

- Impact to a pipeline(s) within the existing pipeline corridor during construction activities;
- Loss of containment from fuel tanks within the construction camp/facilities area;
- Loss of containment from a fuel bowser, drum, Intermediate Bulk Container or fuel transfer container;
- Minor spills associated with leaks/small spills;
- Failure of the sewage treatment plant;
- Overflow of underground oil separators or septic tanks;
- Release of concrete into watercourses or the Caspian Sea; and
- Flood events causing silty water runoff from stockpiles and exposed ground.

Measures to mitigate accidental events have been incorporated at the project design stage and include:

- Pipeline mapping and condition assessment of existing pipelines;
- Construction of culverts/crossings over existing pipelines;
- Use of concrete barriers and buried pipeline protection on the EOP road;
- Bunding and containment; and
- Design of underground and septic tanks.

In addition, procedures and controls will be implemented during the construction to ensure that there is a minimum risk of spills. Key controls include:

- Production of site drainage and pollution hazard maps, showing the sources of potential pollution pathways and key receptors;
- Provision of adequate training in spill response for all personnel; and
- Maintenance of a spills register documenting key details of all spills including remediation works, if required.

Furthermore, a Spill Response Plan will be prepared prior to commencing work on the SD2 Infrastructure Project. This document will be aligned with BP's Oil Spill Response Plans (OSRP) and integrate with those plans maintained by the 3<sup>rd</sup> party pipeline owners that operate those pipelines over which crossings will be installed.

### **13.5 Environmental and Social Management**

The SD2 Infrastructure works will be performed by key contractors, appointed by BP. A rigorous contractor selection process will be in place to ensure that key contractors used during the SD2 Infrastructure Project have effective HSSE Management Systems that align with BP expectations.

The appointed contractor(s) will be required to develop, implement and monitor environment and social requirements through the HSSE Management System (aligned with ISO 14001 and OHSAS 18001 Standard).

The environmental and social management process will benefit from accumulated experience and 'lessons learned' from executing previous projects and a well-established environmental monitoring programme. Other benefits of previous project experience include the development of:

- Effective and reliable procedures for onsite segregation and management of waste;
- A non-hazardous landfill site designed and constructed to EU standards; and
- An effective process for identifying and utilising opportunities for waste recovery and recycling.

### **13.6 Conclusions**

Planning for the SD2 Infrastructure Project has benefited, to a considerable extent, from the experience gained from previous construction projects at the Terminal. Lessons learnt from previous projects have informed the SD2 Infrastructure Project.

In conclusion, the SD2 Infrastructure Project has considered all aspects of its impact on the environmental and socio-economic receptors and incorporated additional mitigation to existing controls to ensure any negative impacts are minimised as far as practicable.

**APPENDIX 2A**

**Shah Deniz Production Sharing Agreement Extract**



## Appendix 2A

### Shah Deniz Production Sharing Agreement Extract

#### ARTICLE XXVI - Environmental Protection and Safety

##### 26.1 Environmental Standards

Contractor shall develop jointly with SOCAR and the State Committee of the Azerbaijan Republic on Ecology and Control over the Use of Natural Resources ("SCE") safety and environmental protection standards and practices appropriate for the regulation of Petroleum Operations. The safety and environmental protection standards shall take account of the specific environmental characteristics of the Caspian Sea and draw, as appropriate, on (i) international Petroleum industry standards and experience with their implementation in exploration and production operations in other parts of the world and (ii) existing Azerbaijan safety and environmental legislation. In compilation of such standards and practices account shall be taken of such matters as environmental quality objectives, technical feasibility and economic and commercial viability. Subject to the first sentence of Article 26.4 the standards, which shall apply to Petroleum Operations from Effective Date shall be the standards and practices set out in part II of Appendix IX until substituted by new safety and environmental protection standards devised and agreed between Contractor, SOCAR and SCE on a date between the Parties and SCE and from such date such agreed standards and practices shall have the force of law as if set out in full in the Agreement. In the event that the safety and environmental protections standards and practices are imposed otherwise than with the agreement of Contractor it is agreed that the provisions of Article 23.2 shall apply. The Parties and SCE shall agree a separate protocol for the detailed implementation of the joint development and definition of the new standards and practices for safety and environmental protection. The cost to Contractor of such development and definition shall be Cost Recoverable.

##### 26.2 Conduct of Operations

Contractor shall conduct the Petroleum Operations in a diligent, safe and efficient manner in accordance with the Environmental Standards to minimise any potential disturbance to the general environment, including without limitation the surface, subsurface, sea, air, lakes, rivers, animal life, plant life, crops, other natural resources and property. Contractor shall implement an integrated management system covering all health, safety and environmental aspects of the activities carried out in relation to the Petroleum Operations as outlined in Part 1 of Appendix IX.

##### 26.3 Emergencies

In the event of emergency and accidents, including but not limited to explosions, blow-outs, leaks and other incidents which damage or might damage the environment, Contractor shall promptly notify SCE (Goskomokhrana) and SOCAR of such circumstances and of its first steps to remedy this situation and the results of said efforts. Contractor shall use all reasonable endeavours to take immediate steps to bring the emergency situation under control and protect against loss of life and loss of or damage to property and prevent harm to natural resources and to the general environment. Contractor shall also report to SOCAR and appropriate Government Authorities on the measures taken.

##### 26.4 Compliance

Contractor shall comply with present and future Azerbaijani laws or regulations of general applicability with respect to public health, safety and protection and restoration of the environment, to the extent that such laws and regulations are no more stringent than the Environmental Standards. In the event any regional or multi-governmental authority having jurisdiction enacts or promulgates environmental standards relating to the Contract Area, the Parties will discuss the possible impact thereof on the project. The provisions of Article 23.2 shall apply to any compliance or attempted compliance by Contractor with any such standards which adversely affect the rights or interests of Contractor hereunder.

## **26.5 Environmental Protection Strategy**

An environmental protection strategy shall be developed which shall include:

- (a) the establishment of an environmental management system as an integral part of Petroleum Operations and the formation of an environmental sub-committee as described in the Environmental Standards.
- (b) an environmental work programme carried out in sequences appropriate to the normal phases of Petroleum Operations as described in the Environmental Standards (seismic survey, exploration drilling, field development and production).

## **26.6 Environmental Damage**

- (a) Contractor shall be liable for those direct losses or damages incurred by a Third Party (other than Government Authority) arising out of any environmental pollution determined by the appropriate court of the Azerbaijan Republic to have been caused by the fault of Contractor. In the event of any environmental pollution or environmental damage caused by the fault of Contractor, Contractor shall reasonably endeavour, in accordance with generally acceptable international Petroleum industry practices, to mitigate the effect of any such pollution or damage on the environment.
- (b) Contractor shall not be responsible and shall bear no cost, expense or liability for claims, damages or losses arising out of or related to any environmental pollution or other environmental damage, condition or problems which it did not cause, including but not limited to those in existence prior to the Effective Date of this Agreement and SOCAR shall indemnify and hold harmless Contractor, its Sub-contractors and their consultants, agents, employees, officers and directors from any and all costs, expenses and liabilities relating thereto.
- (c) Any damages, liability, losses, costs and expenses incurred by Contractor arising out of or related to any claim, demand, action or proceeding brought against Contractor, as well as the costs of any remediation and clean-up work undertaken by Contractor, on account of any environmental pollution or environmental damage (except for such pollution or damage resulting from the Contractor's Wilful Misconduct) caused by Contractor shall be included in Petroleum Costs.

## **ARTICLE XXVI – APPENDIX IX – Environmental Standards and Practices**

### **I. Integrated Management System**

#### **A. Environmental Sub-Committee**

1. The formation and organisation of an environmental sub-committee of the Steering Committee shall be set forth in a proposal of Contractor which will be submitted to SOCAR for approval. Once approved SOCAR, the environmental sub-committee shall be formed in accordance with the approved recommendation and shall be composed of environmental representatives of Contractor Parties and SOCAR, the State Committee of the Azerbaijan Republic on Ecology and Control over the Use of Natural Resources, Azerbaijan Academy of Sciences and other relevant research institutes.
2. Responsibilities of the environmental sub-committee shall be to:
  - Design monitoring programme for monitoring of selected environmental parameters
  - Coordinate monitoring programme
  - Review results and propose recommendations
  - Publish annual report

#### **B. Environmental Work Programme**

The environmental work programme to be pursued during Petroleum Operation pursuant to Article 26.2 shall be phased as follows:

1. For seismic surveys
  - Environmental impact assessment
  - Health, safety and environmental management plan for seismic operations, including emergency procedures, oil spill contingency plan, waste management plan and an audit programme

2. For exploration drilling
  - Drilling environment impact assessment
  - Baseline environmental study
  - Health, safety and environment management plan for exploration drilling, including emergency procedures, oil spill contingency plan, waste management plan (including drill cuttings disposal) and an audit programme
3. For development and production
  - The environmental work programme for the Development and Production Period shall be submitted together with the Development Programme to SOCAR for approval

## **II Environmental Standards**

The following are general and specific guidelines relating to discharges associated with oil and natural gas exploration and production activities.

### **A. General Guidelines**

1. There shall be no discharge of waste oil, produced water and sand, drilling fluids, drill cuttings or other wastes from exploration and production sites except in accordance with the following guidelines.
2. There shall be no unauthorised discharges directly to the surface of the sea. All discharges authorised by these guidelines shall be controlled by discharging into a caisson whose open end is submerged, at all times, a minimum of two (2) feet below the surface of the sea.

### **B. Discharge Guidelines and Monitoring**

#### **1. Produced Water**

- (a) Contractor will endeavour to utilise produced water for reservoir pressure maintenance if, through standard compatibility testing with Caspian Sea water, no damage to the reservoir resulting in a reduction in overall hydrocarbon recovery would occur by mixing the two water streams. In the event that the two water streams are compatible, Contractor may only discharge a volume of produced water after treatment to the Caspian Sea that exceeds the total volume required for reservoir pressure maintenance or in the event of an emergency, accident or mechanical failure. In the event that the two water streams are not compatible, Contractor may discharge produced water to the Caspian Sea after treatment in accordance with generally accepted international Petroleum industry standards and practices.

#### **2. Drill Cuttings and Drilling Fluids**

- (a) There shall be no discharge of oil based drilling fluids, other than low toxicity and biodegradable drilling fluids.
- (b) There shall be no discharge of drill cuttings generated in association with the use of oil based drilling fluids, invert emulsion drilling fluids, or drilling fluids that contain radiation, if any, waste engine oil, cooling oil, gear oil, or other oil based lubricants, other than cuttings generated in association with the use of low toxicity and biodegradable drilling fluids.
- (c) There shall be no discharge of drill cuttings or drilling fluids if the maximum chloride concentration of the drilling fluid system is greater than four (4) times the ambient concentration of the receiving water.
- (d) Prior to the start of the drilling programme, a drilling mud system will be designed and laboratory tested under the US EPA, 96-hour acute toxicity test using mysids shrimp or other indicator organisms of the Caspian Sea agreed between Contractor and SOCAR. Those muds biodegradable and of low toxicity will be authorised for discharge during the drilling programme.
- (e) During drilling operations, mud samples will be collected periodically to determine toxicity using procedures established for the Caspian Sea.
- (f) The composition of the mud system may be altered as necessary to meet changes in the drilling operations. The modified mud system may be discharged if it has been shown to meet the above limits on oil, salinity and toxicity.



### 3. Other Wastes

- (a) Sanitary waste may be discharged from a U.S Coast Guard certified or equivalent Marine Sanitation Device (MSD) with total residual chlorine content greater than 0.5 mg/l but less than 2.0 mg/l as long as no floating solids are observable. The Hach method CN-66-DPD test shall be used to measure the residual chlorine.
- (b) Domestic wastes and grey water may be discharged as long as no floating solids are observable.
- (c) Desalination unit wastes shall be discharged.
- (d) Deck drainage and wash water may be discharged as long as no visible sheen is observable. Oily and clean drainage or wash water shall be segregated: clean water shall be discharged to the sea and oily water shall be treated as provided in B.1 above.
- (e) Trash shall not be discharged offshore. Trash shall be transported to an appropriate land-based disposal facility

### 4. Monitoring

- (a) Produced Water
  1. The volume of produced water discharged and concentration of oil and grease contained in the discharge will be monitored daily.
  2. The daily maximum and monthly average oil and grease concentration will be reported to the appropriate environmental authority monthly.
- (b) Drill Cuttings and Drilling Fluids
  1. An inventory of drilling fluids additives and their volumes or mass added to the drilling fluid system will be maintained for each well.
  2. Drilling fluid properties, including volume percent oil concentration of chlorides, will be monitored daily for each well.
  3. The estimated volume of drill cuttings and drilling fluids discharged shall be recorded daily and reported monthly to the appropriate environmental authority.
- (c) Other Wastes
  1. The estimated volume of other wastes discharged shall be recorded daily and reported monthly to include:
    - (i) Sanitary waste
    - (ii) Domestic waste
    - (iii) Deck drainage and wash water

### **C. Air Emission Guidelines and Monitoring**

Contractor is authorised to discharge air emissions. Such discharges will be limited and monitored in accordance with generally accepted international Petroleum industry standards and practices.

### **D. Safety Guidelines**

Contractor shall take into account subject to the provisions of Article 26.1 relevant Azerbaijani regulations and the following international safety and industrial hygiene standards in conducting its Petroleum Operations under the Agreement:

1. Oil Industry International Exploration and Production Forum (E&P Forum) Reports – HSE Management
2. International Association of Drilling Contractors (IADC) – Drilling Safety Manual
3. Association of Geophysical Contractors International (IAGC) – Operations Safety Manual
4. Threshold Limited Values for Chemical Substances in the Work Environment – American Conference of Governmental Industrial Hygienists.

## **APPENDIX 5A**

### **Emissions Estimate Assumptions**



## Appendix 5A Atmospheric Emissions Estimates

### 1. Introduction

This Appendix provides supplementary information to the emissions calculations presented in Chapter 5: Project Description and includes pollutant emission factors and the basis of emissions estimates for each Onsite Construction Plant.

Emissions were calculated using internationally accepted emission factors and calculating equations, that were calculated based on real time data collected over time. These were obtained from:

- European Environment Agency EMEP/CORINAIR Emission Inventory Guidebook – 2007; and
- United States Environmental Protection Agency AP42.

Table 1 presents the emissions factors for a range of potentially polluting Non-Greenhouse Gas emissions (Non-GHG) and Greenhouse Gas (GHG) emissions, which are considered to be emitted from the combustion of diesel used by the onsite plant. It is anticipated that all onsite plant will be diesel fuelled (use of low sulphur diesel is assumed). There are no standard emission factors for Carbon Dioxide (CO<sub>2</sub>) from non-road vehicle emissions, The US EPA AP42 provides an emission factor calculation method based on brake specific fuel consumption (BSFC) of a diesel engine. The relevant parameters required to calculate the CO<sub>2</sub> emission factor are presented in Table 2.

**Table 1 Emission Factors**

Engine size	Species Emission Factors (g/kWhr)				
	<sup>1</sup> CO <sub>2</sub>	<sup>2</sup> NO <sub>x</sub>	<sup>2</sup> CH <sub>4</sub>	<sup>2</sup> CO	<sup>2</sup> NM VOC
0-20	948	14.4	0.05	8.38	3.82
20-37	948	14.4	0.05	6.43	2.91
37-75	948	14.4	0.05	5.06	2.28
75-130	948	14.4	0.05	3.76	1.67
130-300	948	14.4	0.05	3	1.3
300-560	948	14.4	0.05	3	1.3
560-1000	948	14.4	0.05	3	1.3
>1000	948	14.4	0.05	3	1.3

<sup>1</sup>EMEP/CORINAIR Emission Inventory Guidebook - 2007. Group 8: Other mobile sources and machinery. SNAP Sector 0808 Industry.  
<sup>2</sup>Carbon Dioxide Calculation from US EPA420-R-05-019 Exhaust Emission Factors for Nonroad Engine Modelling NR-010e

**Table 2 Calculations of CO<sub>2</sub> Emission Factor**

CO <sub>2</sub> emissions factors from BSFC <sup>1</sup>		
1,232	g/hp-hr	gCO <sub>2</sub> /hp/hr
948	g/kWhr	gCO <sub>2</sub> /kWhr
Brake Specific Fuel Consumption (BSFC) of Diesel Engine		
50.0	KW	Engine size
0.4	Efficiency	Efficiency of engine
125.0	kJ/s	Engine Fuel Input
44,800.0	KJ/kg	Calorific value of Diesel
0.003	kg/s	Mass Fuel Input
26.0	hp	Power Fuel Input
0.1	g/hp/s	BSFC

<sup>1</sup>Using the equation CO<sub>2</sub> = (BSFC \* 453.6 - HC) \* 0.87 \* (44/12), where;  
 • CO<sub>2</sub> is in g/hp-hr  
 • Brake Specific fuel Consumption (BSFC) is the diesel fuel consumption in lb/hp-hr  
 • 453.6 is the conversion factor from pounds to grams  
 • HC is the in-use adjusted hydrocarbon emissions in g/hp-hr  
 • 0.87 is the carbon mass fraction of gasoline and diesel fuel  
 • 44/12 is the ratio of CO<sub>2</sub> mass to carbon mass

## 2. Methodology

The estimated number of typical key construction plant and vehicles expected to be used onsite during each phase of the SD2 Infrastructure works is presented in Chapter 5 Table 5.4 of the SD2 Infrastructure ESIA. The indicative schedule is presented in Figure 5.4.

Using the schedule (which shows the expected duration and overlapping of phases) and expected number of onsite plant and vehicles per phase. The total number of plant across the construction period has been calculated as presented in Table 3. Operating hours have been calculated assuming plant is operational for 50% of the working day.

**Table 3 Estimated Number of Onsite Construction Plant Operating Hours**

Plant	Total Number of Onsite Project Plant	Operating Hours per Month	Total Plant Hours	Engine Capacity Size (kW)
Air Compressor	185	198	36,630	7.5
Asphalt Paver	160	198	31,680	130.0
Backhoe loader	155	198	30,690	10.0
Bull Dozer	1152	198	228,096	530.0
Compactor Plate	96	198	19,008	6.0
Concrete Mixer	84	198	16,632	1.5
Concrete Pump	37	198	7,326	75.0
Diesel Generator	48	198	9,504	100.0
Dump Truck	974	198	192,852	25.0
Earthworks Compactor	311	198	61,578	10.0
Fork Lift Trucks	324	198	64,152	5.0
Fuel Bowser	103	198	20,394	20.0
JCB Tractor	85	198	16,830	200.0
Mechanical Water Bowser	210	198	41,580	25.0
Mobile Telescopic Crane	90	198	17,820	25.0
Motor Grader	113	198	22,374	25.0
Road Lorry	179	198	35,442	25.0
Road Roller	91	198	18,018	13.0
Sheep foot roller / Vibro roller	81	198	16,038	10.0
Tilting Drum Mixer	73	198	14,454	5.0
Tracked Excavator	87	198	17,226	27.0
Tracked Mobile Crane	124	198	24,552	115.0
Water Pump	107	198	21,186	20.0
Welding Set	76	198	15,048	50.0
Wheeled Loader	47	198	9,306	25.0

Emissions of each onsite plant were calculated by multiplying total plant operating hours and the relevant emission factor from Table 1 (taking into account engine size). The results of this calculation are presented in Table 4.

**Table 4 Estimated Total Project Emissions of Individual Plant**

Plant	Plant Emissions (Tonnes)						
	CO <sub>2</sub>	NO <sub>x</sub>	N <sub>2</sub> O	CH <sub>4</sub>	CO	NM VOC	PM
Air Compressor	260.4	3.96	0.10	0.01	2.30	1.05	0.61
Asphalt Paver	3,904.2	59.30	1.44	0.21	15.49	6.88	5.07
Backhoe loader	290.9	4.42	0.11	0.02	2.57	1.17	0.68
Bull Dozer	114,604	1,740.8	42.3	6.04	362.7	157.2	133.0
Compactor Plate	108.12	1.64	0.04	0.01	0.96	0.44	0.25
Concrete Mixer	23.65	0.36	0.01	0.00	0.21	0.10	0.06
Concrete Pump	520.88	7.91	0.19	0.03	2.07	0.92	0.68
Diesel Generator	900.98	13.69	0.33	0.05	3.57	1.59	1.17
Dump Truck	4,570.6	69.43	1.69	0.24	31.00	14.03	8.73
Earthworks Compactor	583.76	8.87	0.22	0.03	5.16	2.35	1.37
Fork Lift Trucks	304.08	4.62	0.11	0.02	2.69	1.23	0.71
Fuel Bowser	386.67	5.87	0.14	0.02	3.42	1.56	0.91

Plant	Plant Emissions (Tonnes)						
	CO <sub>2</sub>	NO <sub>x</sub>	N <sub>2</sub> O	CH <sub>4</sub>	CO	NM VOC	PM
JCB Tractor	3,191.0	48.47	1.18	0.17	10.10	4.38	3.70
Mechanical Water Bowser	985.45	14.97	0.36	0.05	6.68	3.02	1.88
Mobile Telescopic Crane	422.33	6.42	0.16	0.02	2.86	1.30	0.81
Motor Grader	530.26	8.05	0.20	0.03	3.60	1.63	1.01
Road Lorry	839.98	12.76	0.31	0.04	5.70	2.58	1.60
Road Roller	222.05	3.37	0.08	0.01	1.96	0.89	0.52
Sheep foot roller / Vibro roller	152.04	2.31	0.06	0.01	1.34	0.61	0.36
Tilting Drum Mixer	68.51	1.04	0.03	0.00	0.61	0.28	0.16
Tracked Excavator	440.92	6.70	0.16	0.02	2.99	1.35	0.84
Tracked Mobile Crane	2,676.7	40.66	0.99	0.14	10.62	4.72	3.47
Water Pump	401.69	6.10	0.15	0.02	3.55	1.62	0.94
Welding Set	713.28	10.83	0.26	0.04	3.81	1.72	1.14
Wheeled Loader	220.55	157.46	3.83	0.55	70.31	31.82	19.79

Table 5 summarises the GHG (i.e. CO<sub>2</sub> and CH<sub>4</sub>) and Non-GHG emissions predicted to be generated during the SD2 Infrastructure Project from onsite construction plant, vehicles and generators.

**Table 5 Estimated GHG and Non GHG Emissions Associated with SD2 Infrastructure Activities**

	CO <sub>2</sub> (tonne)	NO <sub>x</sub> (tonne)	CH <sub>4</sub> (tonne)	CO (tonne)	NM VOC (tonne)	GHG <sup>1</sup> (tonne)
<b>TOTAL</b>	137,324	2,120	8	502	244	137,487

1. CH<sub>4</sub> Greenhouse Gas Equivalent = 21 X CO<sub>2</sub>





## **APPENDIX 8A**

### **Public Meeting Presentation and Meeting Minutes**





SD 2  
Infrastructure ESIA Disclosure  
Community meeting

Baku

# Shah Deniz full field development – concept and planned activities

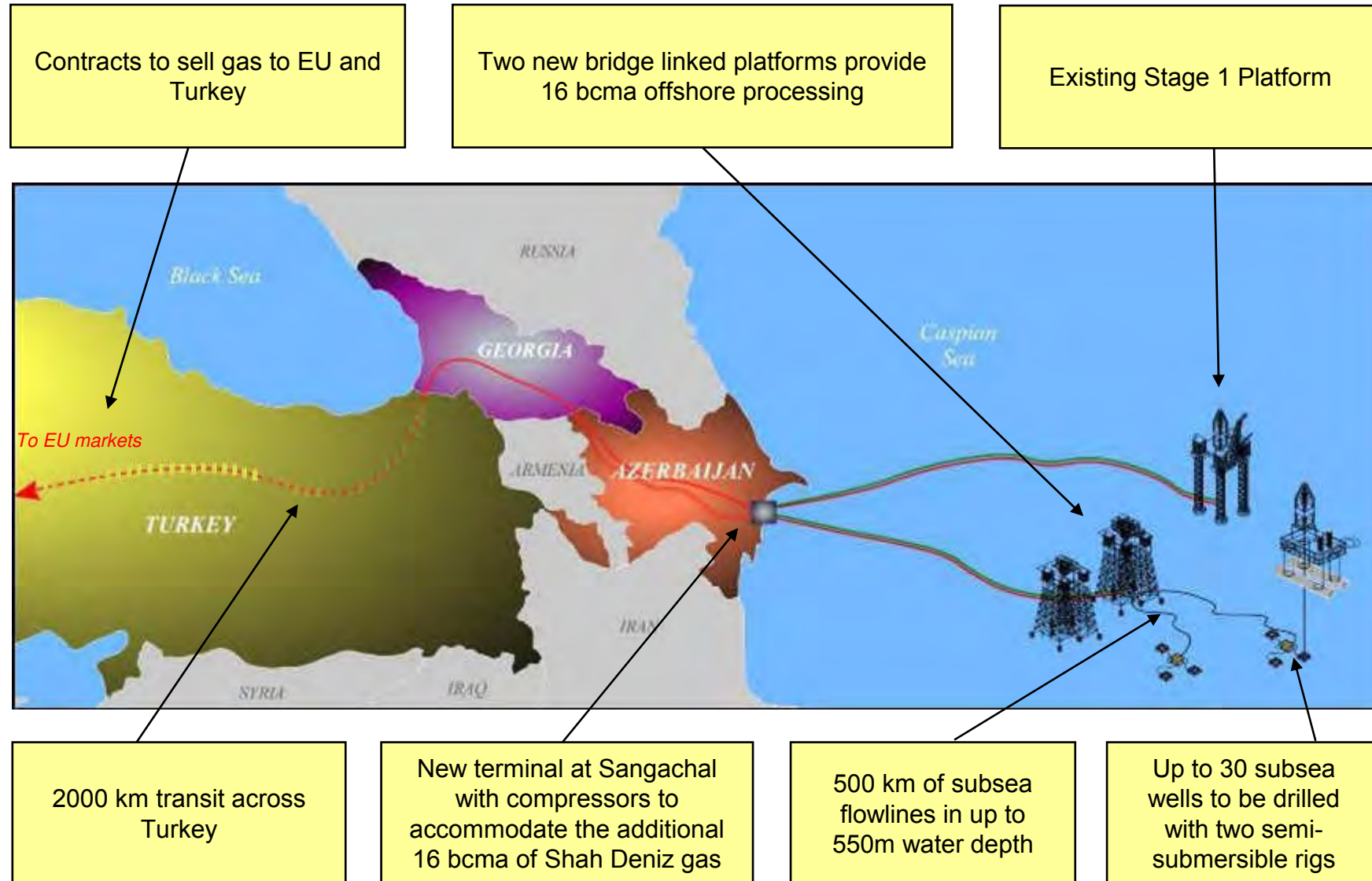

# SD2 Infrastructure Project Scope

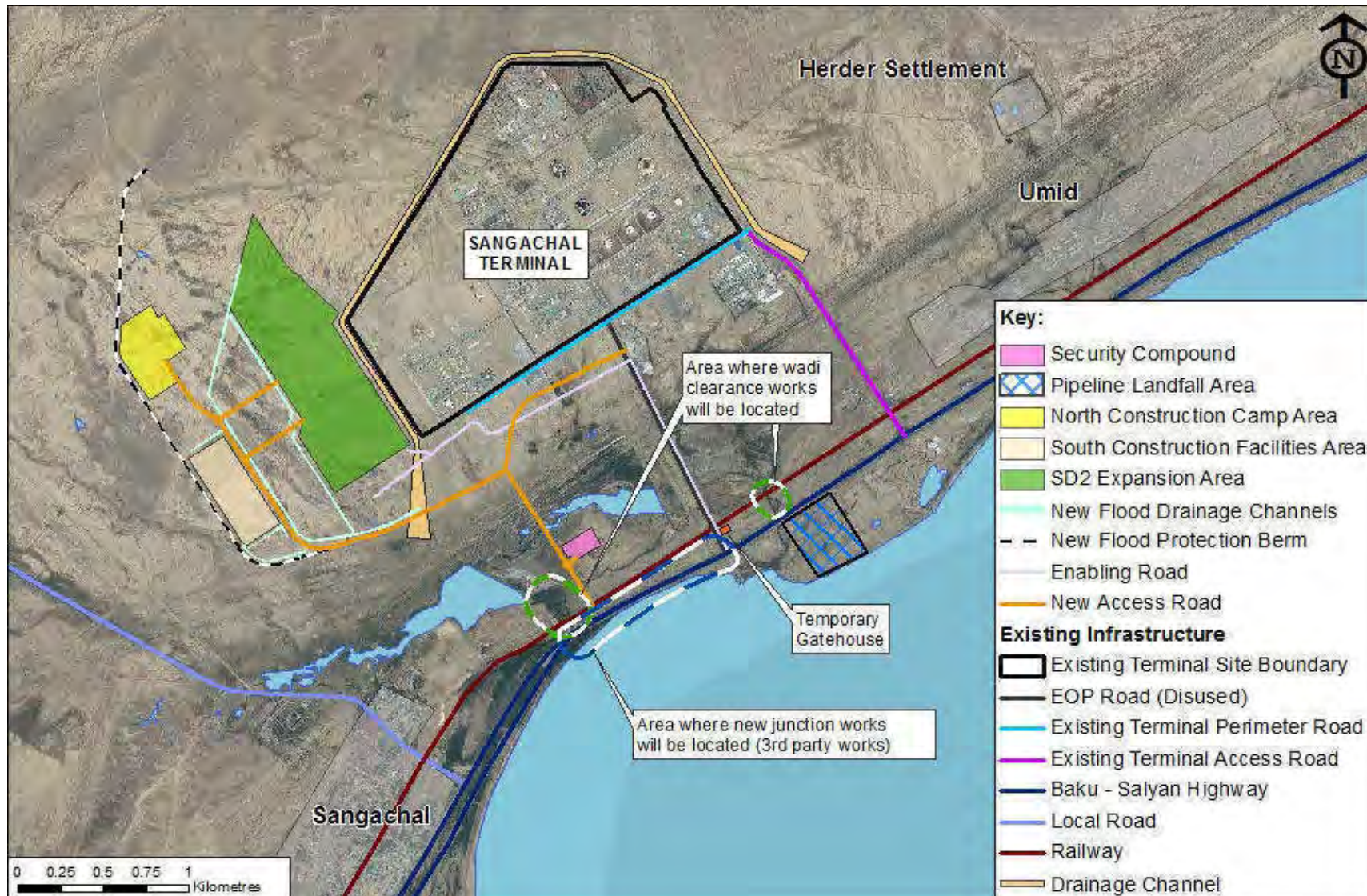



# SD2 Infrastructure Project Overview



- **SD2 Infrastructure Project** comprises works **prior to** main construction, installation, commissioning and operation of SD2 onshore, offshore and subsea facilities.
- SD2 Infrastructure Project scope includes:

- New Terminal access road
- Site clearance and preparation
- Piling
- Construction & fit out of SD2 construction camps
- Planned start of construction Q1 2012

Phase	2012				2013	
	Q1	Q2	Q3	Q4	Q1	Q2
Phase 1 Set Up of Initial Site Compound	■					
Phase 2 Establishment of the Enabling Road and Power Diversion Works	■	■				
Phase 3 Site Preparation	■	■	■			
Phase 4 Main Civils Works		■	■	■	■	■
Phase 5 Earthwork Profiling			■	■		
Phase 6 Construction of Camps and Fit Out			■	■	■	
Phase 7 Closure of Enabling Road and at Grade Rail Crossings						■

# SD2 Infrastructure ESIA – Key Issues



## ➤ **Noise**

- Monitoring and Modelling undertaken, monitoring will continue
- Good plant maintenance and selection will be promoted to reduce site noise

## ➤ **Dust**

- Modelling undertaken and monitoring started this week to improve data
- Mitigation to focus on mechanical/site controls and use of water to suppress dust

## ➤ **Drainage**

- Assessment of flood risk completed
- Design promotes good drainage and does not increase flooding potential
- Working with authorities to improve drainage under rail way line

## ➤ **Cultural Heritage**

- Engagement with Ministry of Culture initiated
- Detailed survey of Infrastructure areas and survey of Caravanserai and cave with IoAE completed
- No significant finds during survey

## ➤ **Employment expectations:**

- Potential positive local impact identified
- BP to work with contractor and C&EA to ensure local recruitment promoted





## SD2 Infrastructure ESI A public meetings

### Meeting Minutes

**Facilitator:** Guivami Rahimli, **Location:** ST Communities  
Azimkend -26 October, 2011  
Sangachal- 26 October, 2011  
Umid - 28 October, 2011

**Organizer:** C&EA

**Minutes by:** Bill Boulton , Ali Aliyev **Date of Meeting:** 26, 28 October 2011

**Participants**  
**BP reps:**

1. Guivami Rahimli, SDI
2. Bill Boulton, SD2 E&S Manager
3. Habiba Bagirova, ST Sr.Environmental Advisor
4. Rustam Hajiyev, ST Health Advisor
5. Ali Gambarchayev, ST Security Manger
6. Ali Aliyev, EA Advisor
7. Shahla Seyidova, Health Advisor

**NGO:** Rasim Jafarguliyev, "Umid" NGO

**Contractors:**

1. Ilgar Yarmamedov (Azfen)
2. Fakhraddin Alimardanov, HR director at Rovshan-Oguz
3. Javidan Askerov, HSE Advisor at Rovshan-Oguz
4. Yusif Hajiyev, General Manager of the Barama Construction Services

---

**Azimkend community meeting** (AzFen representative attended)

**Number of participants : 15**

---

### Introduction by Guivami Rahimli

BP representative opened the meeting and gave information about BP Sangachal Terminal (ST) project, its benefits and environmental impact. He also explained the strategic importance of ST as for Azerbaijan Republic as for BP in Azerbaijan. Then BP representative briefed community members about SD FFD project and future expansion activities around Sangachal Terminal. He informed participants about SD2 Infrastructure ESIA project and planned infrastructure activities throughout 18 months starting from January 2012. Then he demonstrated the copies of SD2 Infrastructure ESIA document and forms for community members' feedback. He stressed that executive summary of ESIA document and feedback forms will be placed in public information centre until November 30, 2011. Facilitator has also mentioned that representatives of contractor companies *AzFen, Rovshan-Oguz and Barama* are present in the room.

Then community members started to ask questions about their environmental concerns and possible support they expect from the company.

**Questions (community members):**

The flame of the gas burning in the adjacent location disturbs us and the flame has grown since last month. What is the reason for that?

**Answer (BP representative):**

At present we carry out sub sea maintenance work on the gas pipe line at CA. It is planned maintenance to keep all facilities in normal working condition. A lot of gas has remained in the pipes after we blocked the delivery which we have to burn via the flare. Therefore the increased flaring is inevitable, otherwise it can cause safety issues and potentially explosion. We carried out noise monitoring at day and night time at community areas to define potential impact on people health. Results show slightly exceeded night level of noise only at Umid village due to constant noise from highway (Baku-Iran) traffic, overhead power (electrical) lines and horn from the train at the moment of testing.

**Question (community member):**

I think that local people should be compensated for the flame impact. We breathe that air. If you compare our nutrition and environmental condition you'll understand the health risks we undergo.

**Answer (BP representative):**

We try to decrease volume of flared gas. Approximately 10000000 m3 of gas is usually delivered to SOCAR which is distributed to gas network to provide Garadaq and other districts with gas supply. We carry out air quality and noise monitoring around ST on systematic basis. The results show that the content of contaminants in the air and noise level don't exceed permissible international and national standards. Also, Ministry of Ecology and Natural Resources controls our activities if we were outside standards they would certainly warn us about it.

**Question (community member):**

Although BP promised to provide our locals with jobs in previous meetings, most of us couldn't get a job in the Terminal?

**Answer (BP representative):**

In the 1<sup>st</sup> Sangachal project we employed about 5000 workers to work in the Terminal. During the infrastructure project the total Azfer workforce will be between 800 to 1000 workers, which includes skilled and unskilled labor. If locals have appropriate qualifications and competency they'll certainly be considered for work and their place of residence will be confirmed. If we don't find adequate skills in communities around the terminal then we will need to recruit from areas outside of the terminal. We'll make sure that majority of contractors are local companies and that community members are employed. Your relatives, friends and neighbors used to and still work in the Terminal and you know that we do our best to involve locals to the business.

**Question (community members):**

During construction works noise and dust is unbearable. Sometimes dust forms clouds.

**Answer (BP representative):**

We understand the magnitude of impact and we do our best to minimize it. Our mitigation measures include watering the site, and other controls to minimise dust and we monitor levels of dust during the work.

**Question (community member):**

Can you help us to improve our school conditions?

**Answer (BP representative):**

The school is in the balance of Ministry of Education and it is their responsibility to do something. As you remember we offered to provide gravel pavement around the school and to fence it. You said you don't need this initiative because Executive Power promised to build a new school. However we still can do it. Anyway, the best way to solve this issue is to go to Executive Power and raise your problems there. All we do as a BP company is only a voluntary support, and it is not our responsibility to do it.

**Community member opinion:** I don't think there is some place like this anywhere in Azerbaijan. We have no tap water system for our washrooms. Children don't come to school during rainfalls due to mud. The roof of the school is leaking. However, a truck of gravel is also something for us. Please do whatever you can and thank you for your initiatives.

**BP representative thanks the participants for attending and closes the meeting.** At the end reminded one more time about the Executive Summary of ESIA document and Feedback forms that will be placed in public information Centre.

---

**Sangachal community meeting** (AzFen representative, as well as local ST contractors Rovshan Oghuz and Barama attended)

**Number of participants : 35**

---

Introductory section - *As above*

**Questions (community members):**

The flame of the gas burning in the adjacent location has grown since last month. We have noticed that and would like to know the reason?

**Answer (BP representative):**

There is gas pipeline coming from two platforms. At present we carry out repair works in the gas station. It is not an emergency repair but a planned maintenance to keep all facilities in normal working condition. A lot of gas has remained in the pipes after we blocked the delivery which we have to burn. The flame/flaring is inevitable, otherwise it can cause explosion. We understand that extra flame/flaring means extra noise. We have carried out noise measurement and it doesn't exceed permissible limits.

**Question (community member):**

We used to have a contact person to inform us of any changes and news. His name is Shafa Rahimov. We don't have him anymore. The increase of flame and other changes in the environment should be informed.

**Answer (BP representative):**

We provided necessary information on flaring to the community leaders, representatives of local authorities and municipalities in Sangachal and Umid, as well as to Azimkend school. So far Sangachal community leader here confirms that he informed all those who were curious about increase of flaring. At the same time we are here to update on current situation and our future plans and we do this on regular basis. Gas burning/flaring is a safety measure that is necessary to control pressure and avoid explosions. In fact we only burn insignificant part of gas which separates from oil. More than 10 mln m<sup>3</sup> of gas we deliver to State Oil Company annually.

**Question (community member):**

You say 1/3 of Rovshan Oghuz employees are local residents but it is not true. They bring workers from outside, register them here and employ them as local residents. In fact, local residents who lived here their whole lives are not able to get jobs in the Terminal. Despite, most of work force we can offer is unskilled labor but we still have skilled labor as well. You bring welders, drivers and other staff from outside when we have all these potentials?

**Answer (BP representative):**

When we employ local residents we can only look at their ID cards or passports. We see that the applicant has local registration and adequate skills we take him. Please give us a list of your workforce divide them into skilled and unskilled and describe the skills. Submit this list to us and that will make sure that we interview the local person and not somebody from outside.

***Question (community member):***

We have problems with fishing. BP doesn't allow us to fish in our original fishing points. Your people came and took our fishing nets 700 meters away. Of course we thank BP for all initiatives but we need our previous fishing locations back.

***Answer (BP representative):***

We'll consider your concern during the planning of future work and previously we corporated with you and assisted in fishing permit issues.

***Question (community member):***

I think that the reality is you don't need any skilled labor. BP is tricking us by bringing labor from outside, registering them here and giving them jobs.

***Answer (BP representative):***

In the 1<sup>st</sup> Sangachal project we employed about 5000 workers to work in the Terminal. During the infrastructure project the total Azfen workforce will be between 800 to 1000 workers, which includes skilled and unskilled labor. If locals have appropriate qualifications and competency they'll certainly be considered for work if their place of residence can be confirmed. If we don't find adequate skills in communities around the terminal then we will need to recruit from areas outside of the terminal. We'll make sure that majority of contractors are local companies and that community members are employed. Your relatives, friends and neighbors used to and still work in the Terminal and you know that we do our best to involve locals to the business.

***Question (community members):***

During construction works noise and dust is unbearable. Sometimes dust forms clouds.

***Answer (BP representative):***

We understand the magnitude of impact and we do our best to minimize it. Our mitigation measures include watering the site, and other controls to minimize dust.

***Question (community member):***

Earlier we had training centers where our young representatives could acquire skills and learn some crafts. Why not open such centers before works start and employ skilled labor from the participants of these trainings?

***Question (community members):***

You have mentioned construction of waste collection areas as BP infrastructure initiative in our settlement. We don't need collection points we need to solve the transportation of solid waste to the landfill site otherwise the waste collection areas will be demolished and all the facilities stolen as previous.

***Answer (BP representative):***

Transportation of solid waste is not our business. There should be a department of Executive Power to deal with it. As to the training centers: Yes we had them before, participants of which could find jobs in different fields.

**BP representative thanks the participants for attending and closes the meeting.** At the end reminded one more time about the Executive Summary of ESIA document and Feedback forms that will be placed in public information Centre.

---

**Umid community meeting** 28 October, 2011

(AzFen representative and local ST contractors Barama attended)

---

**Number of participants : 30**

---

Introductory section – *As above*

***Questions (community members):***

The flame of the gas burning in the adjacent location disturbs us and the flame has grown since last month. We also feel strong smell which disturbs us a lot. What is the reason for that?

***Answer (BP representative):***

At present we carry out repair works in the gas station. It is not an emergency repair but a planned maintenance to keep all facilities in normal working condition. A lot of gas has remained in the pipes after we blocked the delivery which we had to flare. Therefore increased flaring was inevitable, otherwise it can cause explosion. Part of gas is usually delivered to gas network which is distributed to Garadagh and other districts to provide them with gas supply.

***Question (community member):***

We cannot open windows due to strong gas smell.

***Answer (BP representative):***

We measure dust, noise and other forms of impacts regularly. Also we do our best to minimize the impact. And all the measurements show relevance to international standards. Moreover, the smell is caused by produced water.

***Question (community member):***

Do you really think that your initiatives minimize impact?

***Answer (BP representative):***

We try to minimise all impacts. The produced water smell, and other causes are inevitable due to activities carried out in the Terminal. You talk about negative impacts but don't forget that the operation of the Terminal has a lot of positive ones. The Shahdeniz 2 Project envisages start of infrastructure project approximately the first quarter of 2012. We'll need a peak of 800-1000 workforce for that project which will continue 18 months.

***Question (community members):***

How will you organize selection process?

***Answer (BP representative):***

For unskilled labor recruitment from settlements close to Terminal will be prioritised, skilled labor will be selected by means of interviews and check of adequate qualification and capacity. As far as I know our contractor "Rovshan Oghuz" has already employed some labor from Umid. As to filling application forms and writing CVs BP will assist in this process via the NGO working on-behalf of BP in the area. The larger-scale works to start in 2013 will demand more labor.

***Question (community member):***

Our houses are in very poor condition how could you help us to improve our living condition?

***Answer (BP representative):***

The improvement of living condition, especially repair of houses is not our responsibility. We have prepared a program to repair community center and talked with Excom to find out if they can help with funds. 50 percent of contribution should come from your side which is pending. However, knowing your budget hardships we reduced community contribution to 45% and will see what we can do to make it even less or get it provided in the form of workforce and other.

***Question (community member):***

We need improvement of our houses rather than the community center. We thought that new projects and initiatives will include repair of our living places.

***Answer (BP representative):***

Most of your residents are IDP families. The government develops special programs to improve living standards of IDP families. The program is being carried out in certain steps location by location. I hope one day it'll cover your settlement. However, that the repair of houses is not our business.

***Question (community member):***

In fact our priority is the employment of our residents. If one member of each family works this means an income for the family.

***Answer (BP representative):***

We'll do our best to make sure that all the unskilled labor be employed from the closest settlements to the Terminal which are Umid, Azimkend and Sangachal. We have trained 9 young residents from your settlement of which 4 found jobs to apply new skills.

**BP representative thanks the participants for attending and closes the meeting.** At the end reminded one more time about the Executive Summary of ESIA document and Feedback forms that are placed in public information Centre.



## **APPENDIX 9A**

### **SD2 Infrastructure Project Activities, Events and Interactions (Environment)**



**ACTIVITIES/INTERACTIONS**

ID (R=Routine, NR= Non- Routine)	Activity	Scoped In/Out	Project Phase	Reference	Event	Event Category	Receptor
A1-R	Operation of construction plant and vehicles including diesel generators (onsite)	✓	All Phases	-	Emissions to atmosphere (non GHG)	On-site construction plant and vehicles	Atmosphere
					Noise		Terrestrial Environment (Noise)
					Disturbance/indirect effect to wildlife		Terrestrial Environment (Ecology)
A2-R	Construction vehicle movements (offsite)	✓	All Phases	-	Emissions to atmosphere (non GHG)	Offsite construction vehicles	Atmosphere
		✗			Disturbance/indirect effect to wildlife		Terrestrial Environment (Ecology)
					Noise		Terrestrial Environment (Noise)
A3-R	Removal and storage of surface soil layer and vegetation - including pipeline landfall area preparation	✓	Phases 1 & 3	5.5.1, 5.5.3	Disturbance/indirect effect to wildlife	Surface soil layer removal and spoil movement	Terrestrial Environment (Ecology)
					Loss of habitat		Coastal Environment (Ecology & Cultural Heritage)
					Potential disturbance/damage to cultural heritage		Atmosphere
					Dust generation		Terrestrial Environment (Ecology)
A4-R	Movement and temporary storage of spoil	✓	Phase 3	5.5.3	Disturbance/indirect effect to wildlife	Surface soil layer removal and spoil movement	Atmosphere
					Dust generation		Terrestrial Environment (Ecology)
					Potential mobilisation of contamination		Terrestrial Environment (Soil, Groundwater & Surface Water)
A5-R	Subsurface groundworks associated with wadi clearance and new drainage channels	✓	Phase 3	5.5.3	Disturbance/damage to cultural heritage	Subsurface groundworks	Terrestrial & Coastal Environment (Cultural Heritage)
					Potential mobilisation of contamination		Terrestrial Environment (Soil, Groundwater & Surface Water)
					Disturbance/indirect effect to wildlife		Terrestrial Environment (Ecology)
					Loss of habitat		Terrestrial Environment (Ecology)
		✗	Alteration to surface water flow	Terrestrial Environment (Hydrology & Flooding)			
A6-R	Above ground structural groundworks including construction of road embankments, flood protection berm and culverts	✗	Phase 3 & 4	5.5.4	Alteration to surface water flow	Above ground structural groundworks	Terrestrial Environment (Hydrology & Flooding)
					Visual impact		Visual context
A7-R	Piling associated with installation of pipeline crossings	✓	Phase 4	5.5.4	Noise	Piling works	Terrestrial Environment (Noise)
					Potential disturbance/damage to cultural heritage		Terrestrial & Coastal Environment (Cultural Heritage)
A8-R	Test piling	✓	Phase 5	5.5.5	Noise	Piling works	Terrestrial Environment (Noise)
					Potential disturbance/damage to cultural heritage		Terrestrial & Coastal Environment (Cultural Heritage)

ID (R=Routine, NR= Non- Routine)	Activity	Scoped In/Out	Project Phase	Reference	Event	Event Category	Receptor
A9-NR	Sewage Treatment Discharges (following commissioning of SD2 STP)	x	Phase 4	5.5.4	Treated sewage	Discharge of treated sewage	Terrestrial Environment (Soil, Groundwater & Surface Water) Terrestrial Environment (Ecology)
A10-R	Construction plant/vehicle refuelling	x	All Phases	-	Leaks and Spills	Leaks and Spills	Terrestrial Environment (Soil, Groundwater & Surface Water)
A11-R	Erection of temporary structures (e.g. temporary rail crossing gatehouse, security facilities, initial site compound offices)	x	Phases 1,2 & 6	5.5.1, 5.5.2 & 5.5.6	Visual impact	Erection of buildings and structures	Visual context
A12-R	Erection of permanent structures (e.g. construction camp/facility structures)	x	Phase 6	5.5.6			
A13-R	Grit blasting and painting of construction camp/facility structures	x	Phase 6	5.5.6	Dust generation	Completion of buildings and structures	Atmosphere
A14-R	Use of temporary lighting	x	All Phases	-	Indirect effect/disturbance to wildlife (terrestrial)	Temporary lighting	Terrestrial Environment (Ecology)
					Indirect effect/disturbance to wildlife (coastal)		Coastal Environment (Ecology)
					Light impacts (spill/glare) to the community		Light
A15-R	Waste Generation	x	All Phases	-	Generation of hazardous and non hazardous waste	Non-Hazardous Waste	Waste
						Hazardous Waste	
A16-R	Discharge from oil water separators to wadi system	x	All Phases	-	Discharge of treated water	Discharge of treated water	Terrestrial Environment (Soil, Groundwater & Surface Water)
A17-R	Leak test of construction camp drainage pipework	x	Phase 6	5.5.6	Discharge of uncontaminated water	Discharge of uncontaminated water	Terrestrial Environment (Soil, Groundwater & Surface Water)
A18-R	Installation and use of permanent lighting (access road, construction camp and construction facilities)	x	Phase 6	5.5.6	Indirect effect/disturbance to wildlife (terrestrial)	Permanent lighting	Terrestrial Environment (Ecology)
					Light impacts (spill/glare) to the community		Light

Event Category	Event Magnitude			Receptor Sensitivity								Impact Significance						
	Magnitude Parameters	Ranking	Event Magnitude	Sensitivity Parameters	Human	General Biological/ Ecological	Specific Biological/Ecological						Cultural Heritage					
							Breeding Birds	Fauna	Desert/ Semi Desert Vegetation	Wetland Vegetation	Coastal Zone Vegetation			Soil	Surface Water			
impacts to the Atmosphere	Emissions from onsite and offsite construction plant and vehicles	Scale	1	8	Presence	3												Moderate Negative
		Frequency	3			3												
		Duration	3		1													
		Intensity	1		Resilience													
impacts to the Atmosphere	Emissions and dust from surface soil layer removal and spoil movement	Scale	1	8	Presence	2												Moderate Negative
		Frequency	3			3												
		Duration	3		1													
		Intensity	1		Resilience													
Impacts to the Terrestrial Environment (Noise)	Noise associated with construction activities	Scale	1	8	Presence	2												Moderate Negative
		Frequency	3			3												
		Duration	3		1													
		Intensity	1		Resilience													

	Event Category	Event Magnitude			Receptor Sensitivity											Impact Significance
		Magnitude Parameters	Ranking	Event Magnitude	Sensitivity Parameters	Human	General Biological/ Ecological	Specific Biological/Ecological							Cultural Heritage	
								Breeding Birds	Fauna	Desert/ Semi Desert Vegetation	Wetland Vegetation	Coastal Zone Vegetation	Soil	Surface Water		
Impacts to the Terrestrial Environment (Ecology)	Surface soil layer removal and spoil movement	Scale	2	8	Presence			2	2	2	2	2	2			
	Drainage management works) -Wadi Clearance Works	Frequency	1					4	4	4	4	4				
	Drainage management works) - New Drainage Channel Works	Duration	3	2	2			2	2	2						
	Pipeline Landfall Area Preparation	Intensity	2	2	2			2	2							
Resilience																
-																
Moderate Negative																

Event Category	Event Magnitude			Receptor Sensitivity												Impact Significance							
	Magnitude Parameters	Ranking	Event Magnitude	Sensitivity Parameters	Human	General Biological/ Ecological	Specific Biological/Ecological						Cultural Heritage										
							Breeding Birds	Fauna	Desert/ Semi Desert Vegetation	Wetland Vegetation	Coastal Zone Vegetation	Soil		Surface Water									
Environment (Soil, Groundwater and Surface Water)	Mobilisation of contamination during earthworks	Scale	1	6	Presence													-	Moderate Negative				
		Frequency	1																				
		Duration	3		Resilience															2	2	3	4
		Intensity	1																	1	2		
Terrestrial & Coastal Environment (cultural heritage)	Impacts to Cultural Heritage due to earthworks and piling	Scale	2	6	Presence														Moderate Negative				
		Frequency	2																				
		Duration	1		Resilience															3	4	1	
		Intensity	1																				





## **APPENDIX 9B**

### **Visual and Lighting Screening Assessments**



## **1. Visual Screening Assessment**

### **1.1 Introduction**

A screening assessment has been undertaken to understand the potential visual impact of the SD2 Infrastructure Project on the local communities in the vicinity of the Sangachal Terminal, namely Sangachal Town, Azim Kend, Masiv 3 and Umid (refer to Annex A for photographs taken within these communities).

Specifically the assessment has considered the potential visibility of:

- Construction plant and vehicles operating within the SD2 Infrastructure area; and
- Structures (e.g. workshops) to be built within the construction camp and construction facilities areas.

The assessment has made use of viewshed analysis, site visits and photography taken within the local communities and the project information as presented in Chapter 5 of the SD2 Infrastructure ESIA.

### **1.2 Viewshed Analysis Input Data**

The purpose of viewshed analysis to identify whether an assessment point or area is visible or not from a selected receptor. Viewshed analysis is undertaken using specialist tools within a geographic information system (GIS). Input data required includes:

- A digital terrain model (DTM) which provides the topography of the relevant assessment area; and
- Location, height and extent of the feature(s) for assessment.

Viewshed analysis does not take into account any existing buildings or structures and the extent to which they may obstruct a view. As such it provides a conservative indication of visibility based on topography only.

### **1.3 Methodology**

The methodology used to undertake the visual assessment was as follows:

- Define the assessment area and obtain the relevant DTM;
- Determine the sensitive receptors where visibility of project elements are to be considered;
- Determine the assessment scenarios;
- Model visibility using the viewshed analysis tool;
- Estimate the likely visibility from each receptor for each assessment scenario taking into consideration the presence of existing buildings, infrastructure and vegetation based on photography and knowledge of the area obtained through site visits undertaken in 2010 and 2011 as part of various baseline surveys (e.g. noise); and
- Compile and present results and key findings.

#### **Defining the Project Area and Sensitive Receptors**

A DTM was obtained for an area approximately 5km in radius around the existing Sangachal Terminal. This includes the local communities of Sangachal Town, Azim Kend, Masiv 3 and Umid (refer to Figure 1.1 below). The residents of these communities are considered to be sensitive receptors. The impact to views from public areas associated with these communities is therefore assessed.

## Assessment Scenarios

A review was undertaken of the SD2 Infrastructure Project activities as presented in Chapter 5 of the ESIA. The following was determined:

- The main activities would occur within the SD2 Infrastructure area (refer to Figure 1.1);
- Works would occur on site throughout the whole construction period with the greatest activity expected within the SD2 Infrastructure area and specifically within the SD2 Expansion Area where levelling and grading works are planned;
- Onsite activities would mainly involve the use of plant such as excavators, dump trucks and bulldozers (refer to Chapter 5 Table 5.4);
- The majority of the onsite activity will involve earthworks and therefore, while it is planned that cranes will be used on site, their use (e.g. to erect the construction camp structures) will be limited to short periods. Cranes are therefore excluded from the visual assessment;
- Construction camp and construction facilities structures (e.g. warehouses, workshops, accommodation blocks) will be no more than 10m in height (refer to Chapter 5 Section 5.5.6);
- The new flood protection berm (to the west of the SD2 Infrastructure area) will be constructed during Phase 3; and
- The height of the flood protection berm will vary between from 1 to 3m (refer to Section 5.5.3 Chapter 5 Project Description). An average height of 2m is assumed.

The following assumptions were made:

- Height of on site plant (excluding cranes) approximately 3m (based on a review of plant specifications for the types of plant proposed); and
- Average eye level assumed to be 1.6m above ground level.

On the basis of the review above, it is expected that the flood protection berm, which extends along the western boundary of the SD2 Infrastructure area, may provide some visual screening of the plant and vehicles operating at onsite. Given its height, the berm is not expected to provide visual screening of the construction camp and construction facilities structures or plant operating immediately adjacent to the berm.

Three assessment scenarios were considered:

- **Scenario 1 (Construction Plant):** Assess visibility of two points approximately 200m set back from the western boundary of the SD2 Infrastructure area, 3m above ground level (denoted Assessment Location 1 and Assessment Location 2) with and without the berm.
- **Scenario 2 (Construction Plant):** Assess visibility of one point located within the SD2 Expansion Area, 3m above ground level (denoted Assessment Location 3) with and without the berm.
- **Scenario 3 (Structures):** Assess visibility of blocks to a height of 10m across the footprint of the construction camp and construction facilities areas. Blocks were assumed as the location of specific structures is not fixed and therefore this scenario represents a worst case.

Table 1.1 presents a summary of the assessment scenarios. Figure 1.1 shows the assessment locations and the construction camp and construction facilities areas.

**Table 1.1 Assessment Scenarios**

Scenario	Plant/ Structures Assessed	Without Berm	With Berm	Plant Assessment			Structures Assessment
				Assessment Locations	Height of Assessment Locations	Distance set back from berm	Height of structures
1	Plant	✓	✓	1 & 2	3m	200m	-
2	Plant	✓	✓	3	3m	600m	-
3	Structures	✓	✗	-	-	-	10m

**Figure 1.1 Assessment Locations, Construction Camp and Construction Facilities Areas and Location of Sensitive Receptors**

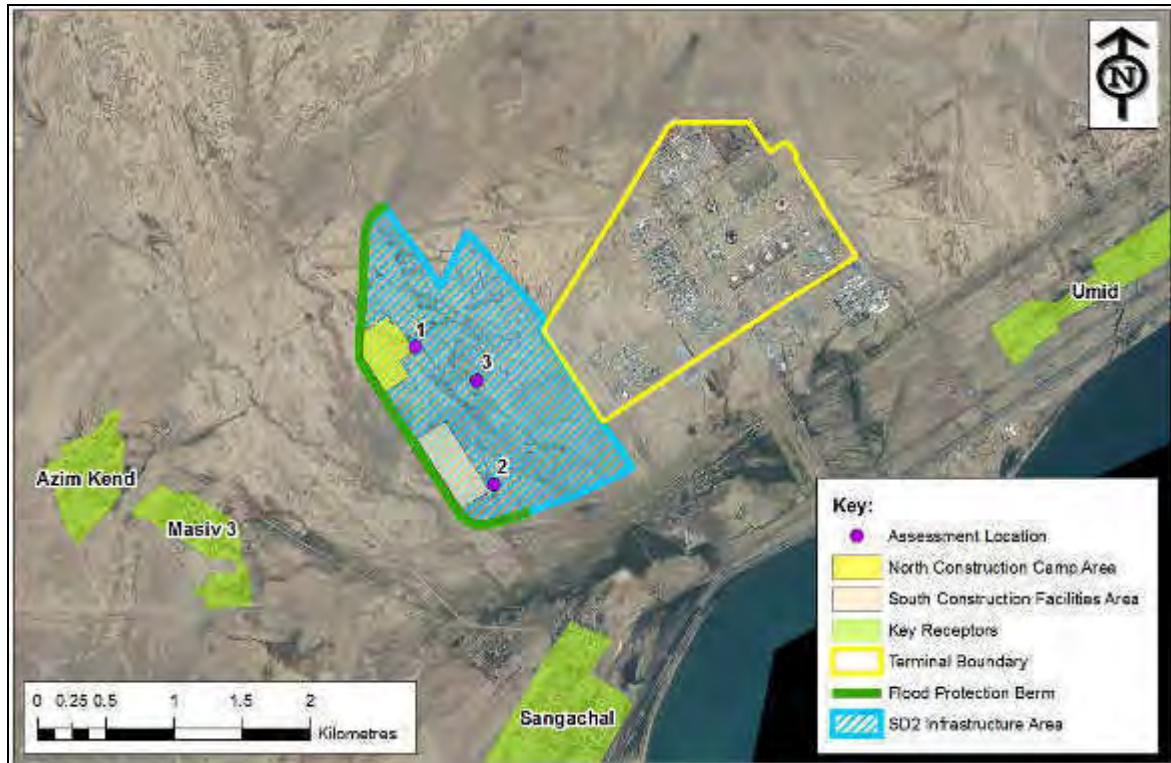

#### 1.4 Viewshed Analysis Results and Key Findings

##### **Scenario 1**

Results of the viewshed analysis for Scenario 1 with and without the flood protection berm in position are shown in Figures 1.2 and 1.3.

The results indicate that the presence of the flood protection berm does not significantly alter the extent of visibility of the two Assessment Locations at the key receptors (i.e. within Sangachal Town, Umid, Azim Kend and Masiv 3).



Figure 1.2 – Viewshed Analysis Scenario 1 without the Flood Protection Berm



Figure 1.3 – Viewshed Analysis Scenario 1 with the Flood Protection Berm

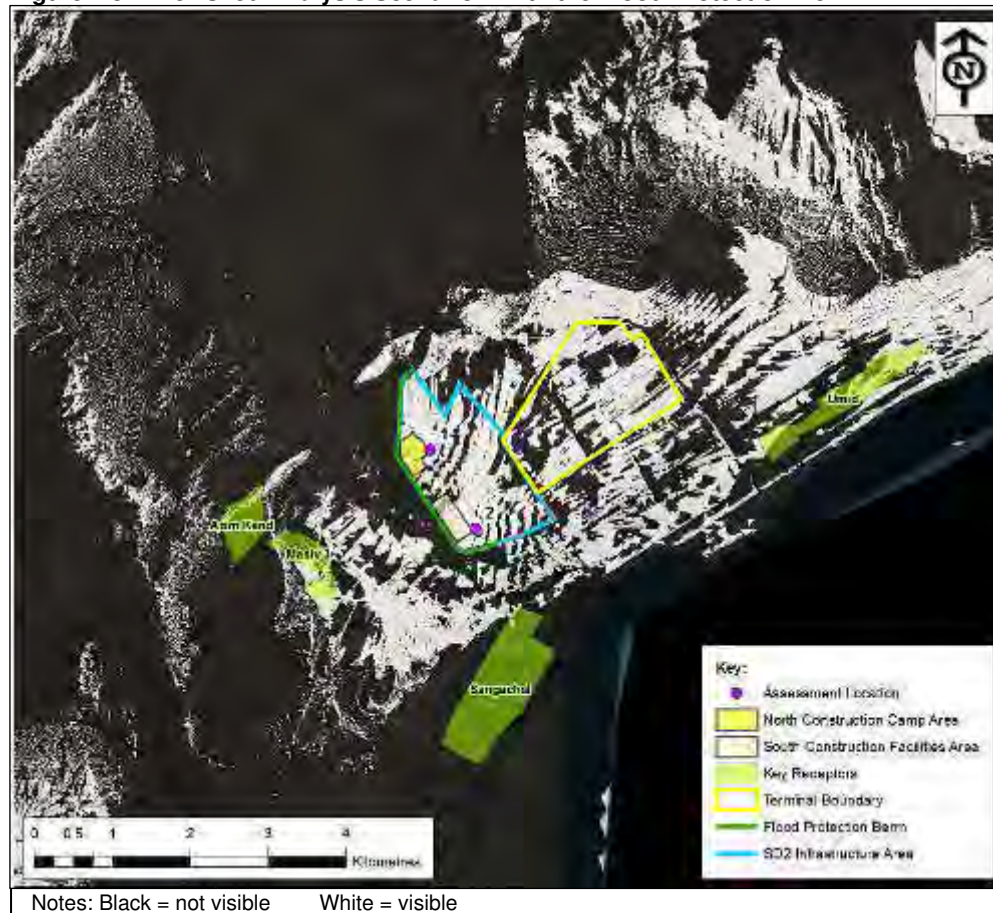



**Umid** – Figures 1.2 and 1.3 indicate that Assessment Locations 1 and 2 may be visible from within the south west and north east of Umid (approximately 25% of Umid by area). However the assessment does not include the structures associated with Sangachal Terminal. Photo A2 (refer to Annex A) suggests that visibility of the Assessment Locations from the south-western corner will be obscured by the existing presence of Sangachal Terminal. Visibility from the north-east part of Umid is likely to be very limited due to the long distance (approximately 6.5km) to the Assessment Locations 1 & 2. The view will continue to be dominated by the existing Sangachal Terminal.

**Sangachal Town** - Figures 1.2 and 1.3 indicate that Assessment Locations 1 and 2 will not be visible from Sangachal Town, with the exception of a very small area (approximately 180m<sup>2</sup>) located at the north western edge (approximately 0.5% of Sangachal Town by area). This is because the line of sight from Sangachal Town to the SD2 Infrastructure area is predominantly obscured by a ridge. Photo A1 (refer to Annex A) within Sangachal Town indicates that views towards the SD2 Infrastructure area from the north west corner of the town is likely to be obscured due to the presence of existing buildings.

**Azim Kend** - Figures 1.2 and 1.3 indicate that the Assessment Locations will only be visible from locations along the northern part of the community (approximately 5% of Azim Kend by area). However, due to the presence of buildings in this area (refer to Photo A4) unobscured views would only be likely from the north eastern edge of Azim Kend. From this location the works would be over 2km away and plant would be barely visible in the views towards the Terminal.

**Masiv 3** – Figures 1.2 and 1.3 indicate that the Assessment Locations will only be visible from locations within the southern area of the community (approximately 35% of Azim Kend by area). The presence of buildings and structures within Masiv 3 indicates that unobscured views are likely only from the south east of the community. However given the relatively long distance between the eastern edge of Masiv 3 and the Assessment Locations (approximately 1.4km) plant is only likely to be barely visible and the structures associated with the existing Terminal (up to approximately 10m in height) would continue to dominate the view (refer to Photo A3).

## **Scenario 2**

The results of the viewshed analysis for Assessment Location 3 with and without the flood protection berm are shown in Figures 1.4 and 1.5.

The figures show:

- The presence of the flood protection berm does not significantly alter the extent of visibility of Assessment Location 3 at the key receptors (i.e. within Sangachal Town, Umid, Azim Kend and Masiv 3); and
- Results obtained for Scenario 2 show no difference to those obtained for Scenario 1.

The Scenario 1 and 2 results indicate that the flood protection berm therefore does not provide complete screening of the plant and vehicles operating within the SD2 Infrastructure Area or within the SD2 expansion Area. The greatest screening is provided by the existing topography in the vicinity of the Sangachal Terminal e.g. the ridge located behind Sangachal Town.

Figure 1.4 – Results from Scenario 2 without the Flood Protection Berm

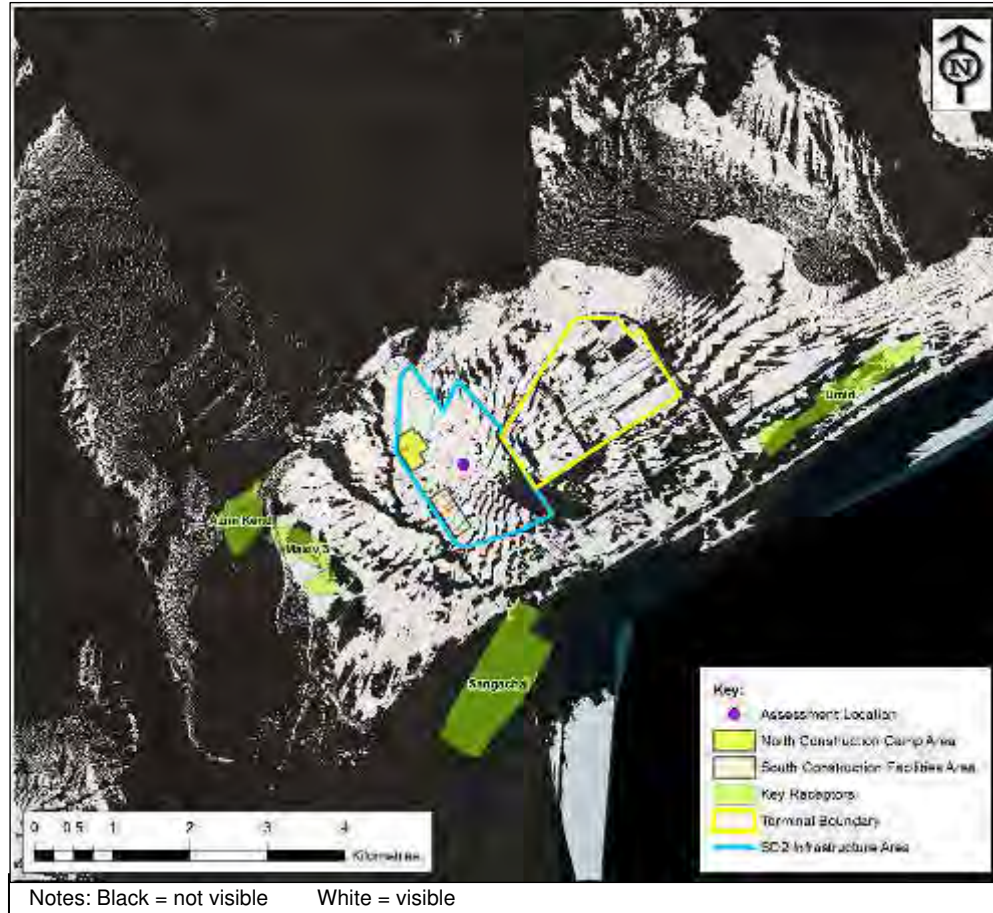
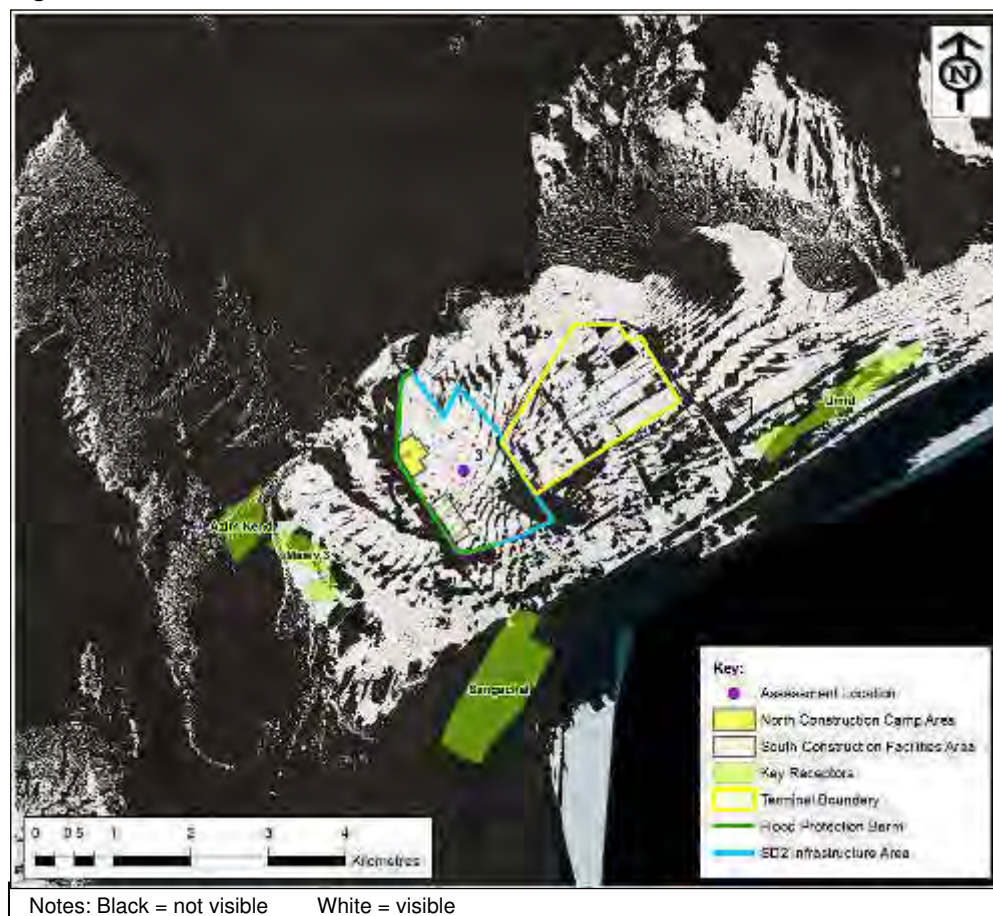

Figure 1.5 – Results from Scenario 2 with the Flood Protection Berm



### Scenario 3

The results of the viewshed analysis for Scenario 3 are shown in Figure 1.6. This Scenario assumes blocks of 10m in height located across the Construction Camp and Construction Facilities Areas.

Figure 1.6 – Viewshed Analysis Scenario 3

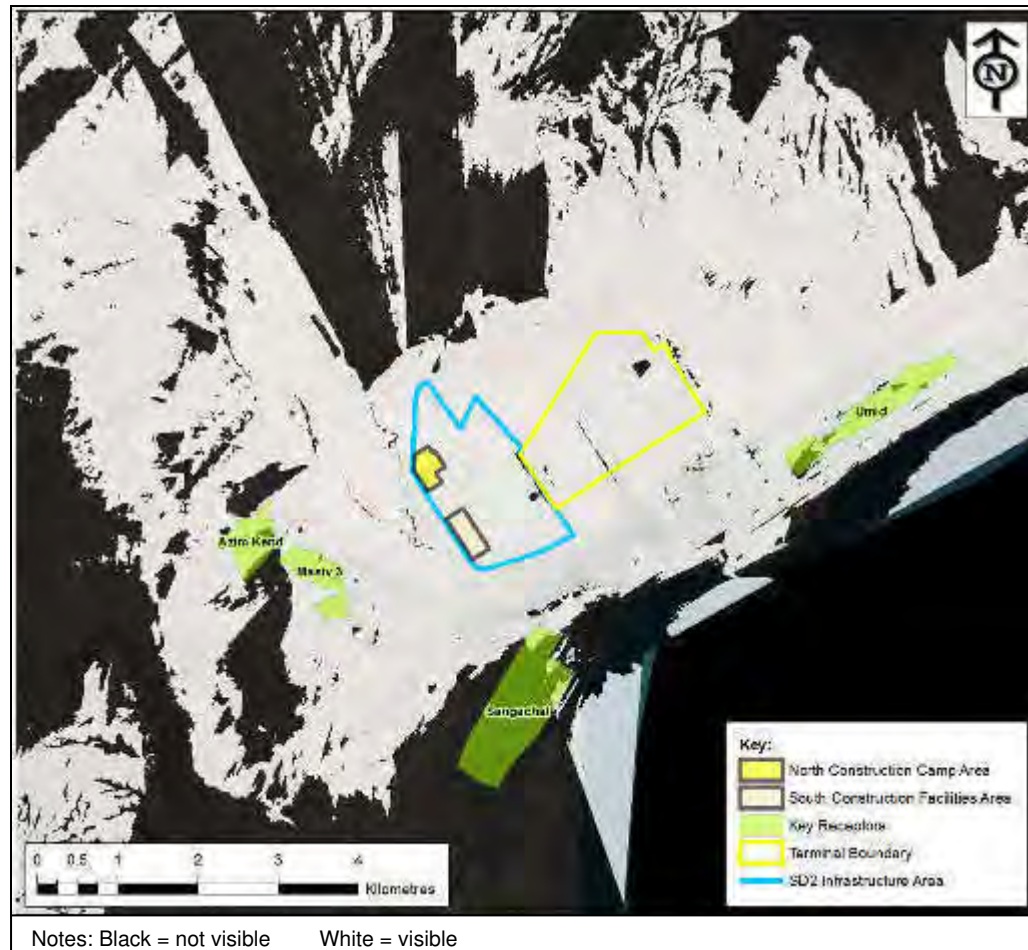

**Umid** - Results of the viewshed analysis indicate that the 10m blocks may be visible from approximately 80% of Umid. However, as for Scenarios 1 and 2, the presence of existing buildings and the Sangachal Terminal will obscure the view towards the SD2 Infrastructure area. The structures within the construction camp and construction facilities areas are therefore unlikely to be significantly visible from Umid. The view will continue to be dominated by the existing Terminal structures.

**Sangachal Town** - The viewshed analysis suggests that the 10m blocks would be visible only from the north and western part of Sangachal Town (approximately 7% of Sangachal Town by area). However as for Scenarios 1 and 2, existing buildings in Sangachal Town will largely restrict views from the west and north. The structures within the construction camp and construction facilities areas are therefore likely to be visible from very limited locations to the north of Sangachal Town.

**Azim Kend and Masiv 3** – The viewshed analysis indicates that the 10m blocks would be visible from the majority of Azim Kend and Masiv 3. In the majority of locations however, the view would be wholly or partially obscured by existing buildings. Locations along western edges of these communities would have a direct and unobscured view towards the construction camp and construction facilities areas. However, the visual impact will be limited as these views are already dominated by the existing structures associated with the



Sangachal Terminal, which are of a height to the proposed construction camp and construction facilities structures

**Summary of Key Findings**

Table 1.2 provides a summary of the area of each community where the assessment locations or structures were shown to be visible based on the viewshed analysis. This analysis considers local topography only and does not take into account existing structures that may obscure views.

**Table 1.2 Areas Within Each Community Where Assessment Locations or Structures May be Visible (Based on Viewshed Analysis)**

Key Receptor	Approximate Area of Community where Assessment Locations/Structures May be Visible				
	Scenario 1		Scenario 2		Scenario 3
	Without Flood Protection Berm	Change with Flood Protection Berm?	Without Flood Protection Berm	Change with Flood Protection Berm?	
<b>Azim Kend</b>	5%	None	5%	None	75%
<b>Masiv 3</b>	35%	None	35%	None	99%
<b>Umid</b>	25%	None	25%	None	80%
<b>Sangachal Town</b>	0.5%	None	0.5%	None	7%

From all receptors the presence of the **flood protection berm** was shown to have **no effect** on the visibility of the assessment locations and structures associated with the SD2 Infrastructure Project.

From **Sangachal Town** the assessment showed that views towards the SD2 Infrastructure area are largely obscured by a ridge located behind the town. It is therefore concluded that views would only be possible from very limited locations.

From **Umid** while the assessment showed that there may be limited views of the construction plant and vehicles (Scenarios 1 & 2) and greater potential for views of the construction camp and construction facilities structures (Scenario 3), the presence of the existing Terminal structures and the distance between the community and the works suggests that views would largely be obscured and very distant.

Similarly from **Azim Kend and Masiv 3** the assessment indicated potential for limited views of the construction plant and vehicles (Scenarios 1 & 2) and greater potential for views of the construction camp and construction facilities structures (Scenario 3). The presence of existing structures within these communities limits the likely visibility of the works within the SD2 Infrastructure area to a small number of locations. In these locations however views are currently dominated by the existing Terminal structures.

In summary at each key receptor it is expected that there will be very limited visibility of the construction plant and vehicles (Scenarios 1 & 2) and structures associated with the construction camp and construction facilities (Scenario 3) since views will be largely obscured by existing structures. Where views are possible, the works would not dominate or significantly alter the existing view and no significant visual impacts are anticipated.

## 2. Lighting Screening Assessment

### 2.1 Introduction

A lighting assessment was carried out at and in the vicinity of the Sangachal Terminal in May 2010 to understand the existing light levels within the local communities (Sangachal Town, Umid, Azim Kend and Masiv 3) and the existing contribution to light levels from the Terminal.

### 2.2 Methodology

Light can be defined as a type of radiation and it forms part of the electromagnetic spectrum visible to the eye. Light is measured in lumen (lm). The amount of light which falls onto a surface is known as illuminance and this is measured in lumens per square metre or lux<sup>1</sup>.

There is currently no national guidance on lighting assessments and as such this assessment has considered best practice guidance produced by the International Commission on Illumination (CIE) and the Institution of Lighting Engineers (ILE). The guidance is set out in the CIE's "Guide on the limitations of the effect of obtrusive light from outdoor lighting installations"<sup>2</sup> and the ILE's "Guidance notes for the reduction of obtrusive light".

In order that light in environmentally sensitive areas is controlled the ILE has recommended the following environmental zones for development areas:

- E1 - Intrinsically dark areas. National Parks, Areas of Outstanding Natural Beauty;
- E2 - Low district brightness areas. Rural or small village locations;
- E3 - Medium district brightness areas. Small town centres or urban locations; and
- E4 - High district brightness areas. Town centres with high levels of night time activity.

Given the rural setting of the four communities the zone applicable to them is E1. The recommended lighting conditions for the E1 zones is 2 lux for Pre-curfew (23.00 hours) and 1 lux post-curfew (from public roads lighting installations only).

### 2.3 Monitoring Locations

A survey of the existing Terminal boundary lighting was undertaken to establish the sources and extent of the boundary lighting. Where possible, boundary lighting was recorded noting the type and direction of the lighting.

Monitoring locations were selected in each of the four communities surrounding the Terminal at a point where the Sangachal Terminal lighting at night was most visible. These locations were selected to provide a "worst case" assessment. The monitoring locations at the surrounding communities were selected away from local light sources in order to focus the assessment on the impact of light from the Terminal.

Table 2.1 sets out the position of the monitoring locations and relative distances to the Terminal boundary (see Figure 2.1).

<sup>1</sup> Department for Environment, Food and Rural Affairs (DEFRA), 2006. Statutory Nuisance from Insects and Artificial Light: Guidance on Sections 101 to 103 of the Clean Neighbourhoods and Environment Act 2005

<sup>2</sup> Commission International Éclairage (CIE), 2003. Guide on the limitations of the effect of obtrusive light from outdoor lighting installations. Publication No 150 2003.

**Table 2.1 Distances of the Communities from the Sangachal Terminal Boundary**

ID	Monitoring Location	GPS Reference		Approximate Distance from the Terminal Boundary (km)	Direction from Terminal Boundary
		Northing	Easting		
C1	Azim Kend	40 11.491	49 25.621	3	South east
C2	Masiv 3	40 11.142	49 26.101	2.6	South east
C3	Sangachal	40 10.627	49 27.827	1.6	South east
C4	Umid	40 11.850	49 30.065	1.1	South west

**Figure 2.1 Light Assessment Monitoring Locations**

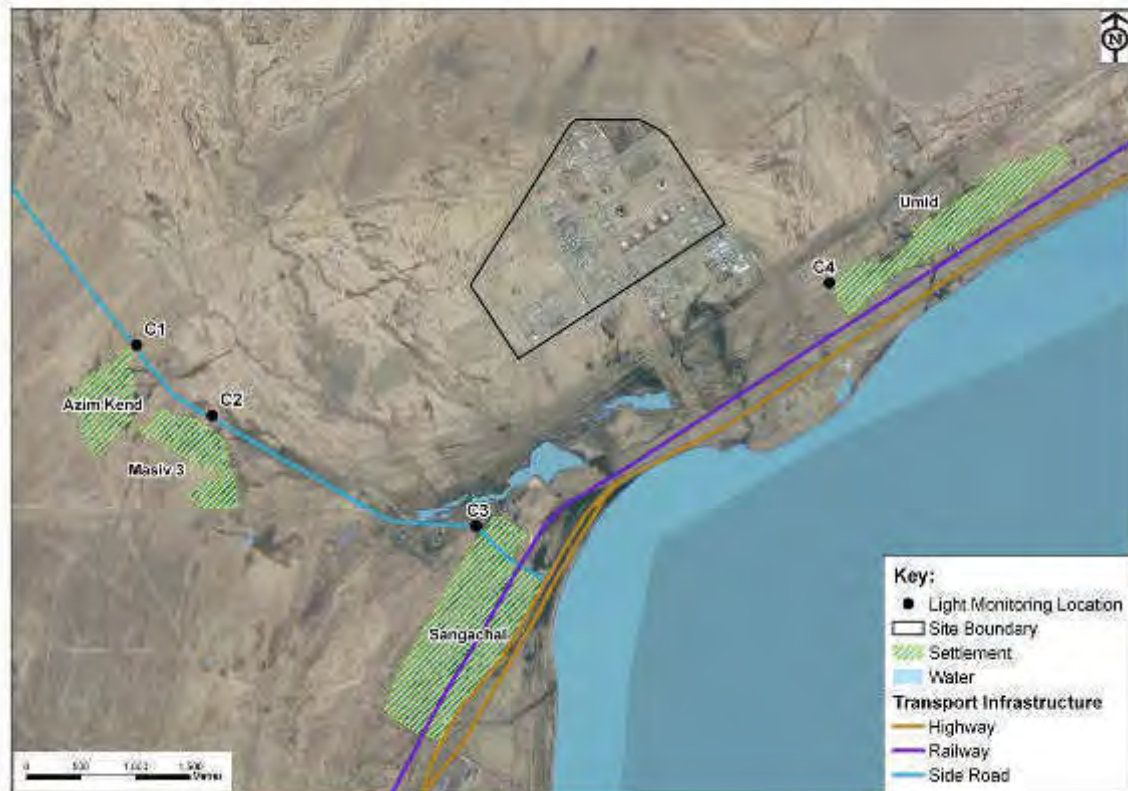

## 2.4 Results

In addition to the boundary lighting of the existing Terminal and due to the fact that the site is in operation for 24 hours, all plant and machinery within the existing Terminal is lit at night for safety and security reasons. A large proportion of the plant extends above the height of the boundary lighting such as the tanks and flares (see Figure 2.2). The Terminal boundary road is also illuminated with high pressure sodium luminaries. The view of the Terminal from all four communities includes boundary lighting, plant lighting and light from the flares<sup>3</sup>.

<sup>3</sup> During the lighting baseline survey the flares were operating under routine conditions. Light increases when additional gas is flared in non routine conditions (e.g. emergency depressurisation).

**Figure 2.2 Photo from Sangachal Showing Boundary and Plant Lighting of the Terminal**



Table 2.2 presents the findings of the lighting monitoring undertaken on 18 and 19/20 May 2010.

**Table 2.2 Lux Measurements in the Communities**

ID	Monitoring Location	Approximate Distance (km) and Direction from the Terminal Boundary	Lux Value		ILE Lux Limit		Comment
			18 May	19 May	Pre-curfew	Post-Curfew	
C1	Azim Kend	3km south west	0.14	0.06	2	1	Limited lighting approximately 50m south of the monitoring location
C2	Masiv 3	2.6m south west	0.08	0.06			-
C3	Sangachal	1.6km south west	0.1	0.05			Low level lighting interference from the power station to the south west of the monitoring location.
C4	Umid	1.1km south east	0.21	0.2			-

The lighting impact of the Terminal on the surrounding communities was most evident at the Umid monitoring location (C4), located approximately 1.1km to the south east of the Terminal. The average illuminance value recorded at the C4 location was 0.2 lux. The recommended level as set out by the ILE (refer to Table 2.2 above) is 1 lux post-curfew and as such the impact of the Terminal on Umid is well within the requirements of the ILE Guidelines. The measurements from monitoring locations C1 – C3 ranged between 0.05 – 0.14 lux, well below the maximum light intensity levels set out in the guidance document. Annex B includes photographs taken from the communities of the Terminal at night.

#### 1.4 Conclusion

The Terminal has been identified as the dominant source of light from all communities. The lighting survey has determined that light levels within the communities do not result in obtrusive light levels according to ILE guidance.



# **Annex A –Photographs of the Communities**

**Photo A1 - View of Sangachal Town in a westerly direction (away from Sangachal Terminal)**



**Photo A2 - View from western edge of Umid looking Eastwards towards Sangachal Terminal**



**Photo A3 - View from the Eastern Edge of Masiv 3 looking Eastward towards Sangachal Terminal**



**Photo A4 - View from Azim Kend looking towards the South-East**



## **Annex B – Lighting Photographs**

**Photo B1 - View of Sangachal Terminal from Azim Kend**



**Photo B2- View of Sangachal Terminal from Masiv 3**

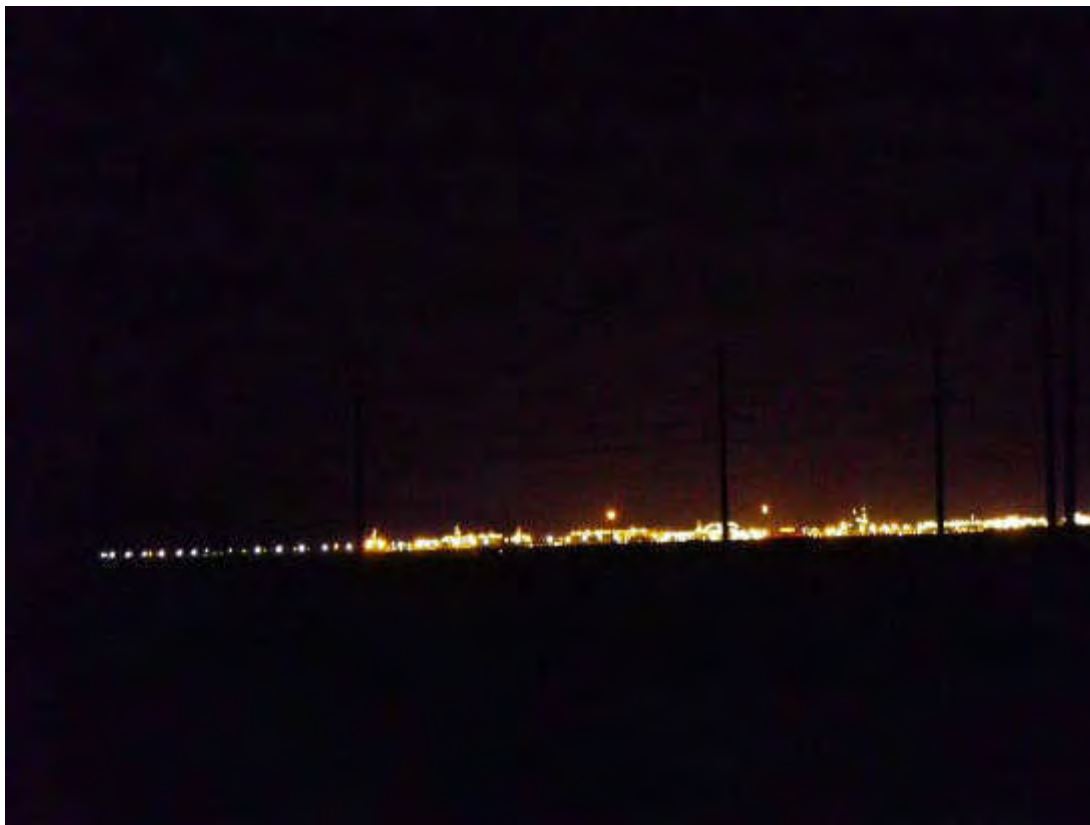

**Photo B3 - View of Sangachal Terminal from Sangachal Town**



**Photo B4- View of Sangachal Terminal from Umid**







## **APPENDIX 9C**

### **Air Quality Assessment for Construction**





## **SD2 Infrastructure Project**

### **Air Quality Assessment for Construction**

13 July 2011

Issue No 3  
49316163

**Project Title:** SD2 Infrastructure Project  
**Report Title:** Air Quality Assessment for Construction  
**Project No:** 49316163  
**Report Ref:** 2431  
**Status:** Draft Report  
**Client Company Name:** BP Exploration (Shah Deniz) Ltd  
**Issued By:** URS Corporation Ltd

**Document Production / Approval Record**

Issue No:	Name	Signature	Date	Position
2				
Prepared by	Matthew Mitchell		13 <sup>th</sup> July 2011	Senior Consultant
Checked by	Neil Tittley		13 <sup>th</sup> July 2011	Principal Consultant
Approved by	Anna Rouse		13 <sup>th</sup> July 2011	Principal Consultant

**Document Revision Record**

Issue No	Date	Details of Revisions
1	20 <sup>th</sup> May 2011	Original report
2	13 <sup>th</sup> July 2011	Amended report incorporating client comments

## CONTENTS

SECTION	PAGE NO
<b>EXECUTIVE SUMMARY.....</b>	<b>5</b>
Units and Abbreviations.....	9
<b>1. INTRODUCTION.....</b>	<b>11</b>
1.1 Scope .....	11
<b>2. METHODOLOGY .....</b>	<b>13</b>
2.1 Air Quality Limits and Other Study Pollutants .....	13
2.2 Model Selection.....	15
2.3 Model Input Parameters .....	17
2.4 Conversion of NO <sub>x</sub> to NO <sub>2</sub> .....	21
2.5 Meteorology.....	22
2.6 Model Domain and Specified Receptors.....	23
<b>3. BASELINE CONCENTRATIONS.....</b>	<b>25</b>
3.1 NO <sub>2</sub> and PM <sub>10</sub> .....	25
3.2 Dust Deposition.....	26
<b>4. SCREENING ASSESSMENT RESULTS .....</b>	<b>26</b>
4.1 Earth Moving and Construction Activities .....	26
4.2 Onsite Construction Plant .....	29
4.3 Offsite Road Vehicles.....	30
<b>5. CONCLUSIONS.....</b>	<b>31</b>
<b>6. REFERENCES.....</b>	<b>34</b>

## **LIMITATION**

URS Corporation Limited (URS) has prepared this Report for the sole use of BP Exploration (Shah Deniz) Ltd in accordance with the Agreement under which our services were performed. No other warranty, expressed or implied, is made as to the professional advice included in this Report or any other services provided by us. This Report may not be relied upon by any other party without the prior and express written agreement of URS. Unless otherwise stated in this Report, the assessments made assume that the sites and facilities will continue to be used for their current purpose without significant change. The conclusions and recommendations contained in this Report are based upon information provided by others and upon the assumption that all relevant information has been provided by those parties from whom it has been requested. Information obtained from third parties has not been independently verified by URS, unless otherwise stated in the Report.

## **COPYRIGHT**

© This Report is the copyright of URS Corporation Limited. Any unauthorised reproduction or usage by any person other than the addressee is strictly prohibited.

## EXECUTIVE SUMMARY

*This report presents the findings of a screening assessment of predicted atmospheric emissions associated with the construction of the Shah Deniz 2 (SD2) Infrastructure Project.*

*The SD2 Infrastructure Project includes the works that are required prior to the construction, installation, commissioning and operation of the onshore SD2 facilities within the SD2 Expansion Area at the Sangachal Terminal.*

*This report considers the effect of the following activities associated with the SD2 Infrastructure Project:*

- *Dust generation attributed to earth moving and construction activities;*
- *Exhaust emissions from onsite construction plant; and*
- *Exhaust emissions arising from offsite road traffic movements associated with the SD2 Infrastructure Project.*

### **Methodology**

*Dust generation and onsite plant emissions have been assessed using the ADMS4 dispersion model (version 4.2). Emissions associated with offsite road vehicle movements have been considered using the Design Manual for Roads and Bridges (DMRB) screening tool (1.03c).*

*For the assessment of **dust emissions and construction plant emissions**, a two dimensional Cartesian grid system has been used based on the 'Pulkovo 1942' coordinate system, using the 'Krasovsky 1940 spheroid'. The 4km x 4km grid is centred on the SD2 Expansion Area, with 80 receptor points (resulting in a modelled concentration every 50m). Four sensitive receptor locations were also included in the ADMS4 model at which the effect of the atmospheric emissions has also been calculated. These include Azim Kend/Masiv 3, Sangachal Town, Umid, and a nearby Herder Settlement.*

*For the assessment of **offsite road traffic emissions** the closest residential location to the Baku-Alyat Highway, (approximately 20m from the southbound carriageway within Sangachal Town) was selected and the contribution to NO<sub>2</sub> concentrations at this location associated with project traffic estimated DMRB screening .*

### **Assessment Criteria**

*Dust emissions (which comprise both suspended and deposited particulate matter up to 75 microns (µm) in diameter) associated with **earth moving and construction activities** have been evaluated. In the absence of international limits for dust deposition the potential for nuisance has been assessed against guidance limits used in Western Australia and Argentina (which represents the most stringent limit based on a literature review of available limits). PM<sub>10</sub> concentrations associated with these activities have also been modelled and the contribution at receptors assessed against relevant limit values.*



**Construction plant and offsite road traffic emissions** arise from combustion of fuels. The key species of concern in this study is  $NO_2$ . This species and relevant averaging periods have been modelled to assess the contribution of emissions from the project at the selected receptors against the applicable air quality limit values, set for the protection of human health.  $PM_{10}$  concentrations associated with road traffic have also been modelled and compared to the relevant limit value<sup>1</sup>.

The predicted  $NO_2$  and  $PM_{10}$  concentrations at receptors have been assessed against the project limits provided in the SD2 Environmental Basis of Design. The following table presents a summary of modelling undertaken.

	Parameter Modelled			Model
	$NO_2$	$PM_{10}$	Dust	
<b>Earth moving and construction activities</b>		✓	✓	ADMS4.2
<b>Construction plant</b>	✓			ADMS4.2
<b>Road traffic</b>	✓	✓		DMRB

Project limit values also exist for  $SO_2$ , however this pollutant species has not been assessed for site plant or offsite road traffic because of the relatively low sulphur content of vehicle fuels in Azerbaijan. For example,  $NO_x$  emissions are expected to be 9.5 times higher than  $SO_2$  from offsite road vehicles and site plant (see Section 2.1.1 for more detail).

Historically in Azerbaijan ambient concentrations of  $NO_2$  and  $PM_{10}$  have also been assessed against specific 24 hour and 1 hour standards. These standards were not derived using the same health based criteria as the IFC, WHO and EU guideline values and the standards derived are not widely recognised. For completeness the estimated  $NO_2$  and  $PM_{10}$  emissions associated with the SD2 Infrastructure Project activities have been compared to the historic Azeri standards

### Model Input Parameters

The potential generation of airborne particles during **earth moving and construction activities** has been estimated using the United States Environmental Protection Agency (US EPA) document 'Fugitive Dust Sources' where appropriate emission factors are provided.

The number and type of **site plant and offsite road vehicles** and the expected project activities are based on the data (as estimated by the project engineers) presented in Chapter 5: Project Description of the SD2 Infrastructure Project ESIA. Emission rates have been estimated from the EMEP/CORINAIR Emission Inventory Guidebook.

The meteorological data used in the dispersion modelling (including sunlight, temperature and wind data) was based on the available measurements made at Sangachal Terminal and supplemented by data from Baku Airport for the year (2007). No meteorological data is required for the DMRB road traffic assessment.

<sup>1</sup>  $PM_{10}$  emissions from onsite plant have not been included within the ADMS4 model. These are estimated to be a factor of 10 times less than  $NO_x$  emissions (and therefore the significance of the impact can be extrapolated from the  $NO_x$  output), and indiscernible in comparison with the dust generated during earth moving and construction activities. Refer to Section 2.3.2 for more details.

## Conclusions

The results of the modelling undertaken are presented in the following table.

	Modelled Increase at Receptors <sup>1</sup>			Increase as % of Relevant Limit/Guidance Value <sup>2</sup>		
	NO <sub>2</sub> Concentration (µg/m <sup>3</sup> )	PM <sub>10</sub> Concentration (µg/m <sup>3</sup> )	Dust Deposition (mg/m <sup>2</sup> /day)	NO <sub>2</sub>	PM <sub>10</sub>	Dust Deposition
<b>Earth moving and construction activities</b>	N/A	0.1 - 0.3	1.7 - 9.8	N/A	0.5 - 1.5%	1.3 – 7.4%
<b>Construction plant</b>	<0.1	N/A	N/A	N/A	N/A	N/A
<b>Offsite road traffic</b>	0.9	0.2	N/A	2.2%	1%	N/A
<b>All activities</b>	<b>0.9</b>	<b>0.3 - 0.5</b>	<b>2-10</b>	<b>2.2%</b>	<b>1.5 - 2.5%</b>	<b>1.3 – 7.4%</b>

**Notes:**

1. NO<sub>2</sub> and PM<sub>10</sub> background concentrations are 6 µg/m<sup>3</sup> and 109µg/m<sup>3</sup> respectively as determined from 2010 air quality monitoring report.

2. NO<sub>2</sub> annual average limit value = 40µg/m<sup>3</sup> PM<sub>10</sub> annual average limit value = 20µg/m<sup>3</sup>, dust nuisance guideline = 133 mg/m<sup>2</sup>/day.

The findings of the screening assessment are:

- **PM<sub>10</sub> emissions (associated with construction dust)** – The modelling predicts a contribution of between 0.1 and 0.3 µg/m<sup>3</sup> to PM<sub>10</sub> concentrations at the receptors modelled from earth moving and construction activities. This constitutes 0.5 - 1.5% of the annual average PM<sub>10</sub> limit value (20 µg/m<sup>3</sup>) and represents less than 0,1% of the traditional Azeri 24 hour limit value (100 µg/m<sup>3</sup>);
- **Dust deposition** - The results obtained at sensitive receptors shows that the maximum daily rate of deposition offsite due to earth moving and construction activities is predicted to be between 1.7 and 9.8 mg/m<sup>2</sup>/day (on an annual basis). This represents 1.3 – 7.4% of the guidance levels and would be imperceptible in comparison with background levels. The maximum worst case daily dust deposition rate was also modelled with the highest rate of 132mg/m<sup>2</sup>/day estimated at Sangachal. This is comparable to the most stringent guidance value for dust deposition found in literature;
- **Onsite plant and equipment emissions (NO<sub>2</sub> emissions)** - The modelling predicts that exhaust emissions from onsite plant and equipment are anticipated to lead an increase of less than 0.1 µg/m<sup>3</sup> in NO<sub>2</sub> and PM<sub>10</sub> concentrations at modelled receptors;
- **Offsite road vehicle emissions (NO<sub>2</sub> and PM<sub>10</sub> emissions)** - A contribution of up to 0.9 µg/m<sup>3</sup> to NO<sub>2</sub> concentrations and less than 0.2 µg/m<sup>3</sup> to PM<sub>10</sub> concentrations is predicted at the selected receptor 20m from the Highway. This represents 2.2% of the annual average air quality project and traditional Azeri limit values for NO<sub>2</sub> and 0.5% of the annual average air quality project for PM<sub>10</sub>.

- **Overall contribution from SD2 Infrastructure Project activities (NO<sub>2</sub> and PM<sub>10</sub> emissions)** –The cumulative impact of construction site and plant and the road traffic activities on PM<sub>10</sub> concentration at nearby sensitive receptors is expected to be 0.1-0.3 µg/m<sup>3</sup>. The cumulative impact on NO<sub>2</sub> concentrations will vary across receptors. Nearer to the Highway the contribution to NO<sub>2</sub> concentrations is predicted to be a maximum of 0.9 µg/m<sup>3</sup>, within the communities both onsite plant and offsite vehicle emissions are predicted to lead to increase of less than 0.1 µg/m<sup>3</sup>.
- **Compliance with applicable limit values** - When taking account of the existing background concentrations the predicted NO<sub>2</sub> concentrations easily comply with the applicable air quality limit values<sup>2</sup>. This is not the case for PM<sub>10</sub>, because PM<sub>10</sub> background concentrations already exceed the applicable limit values - this is considered to be predominantly a consequence of the dusty nature of the region.

In summary, it is not expected that the project will cause any air quality limit values to be exceeded where concentrations currently comply with the limit values. Where limits are currently exceeded (i.e. PM<sub>10</sub>) the contribution from the project (from plant, earth moving activities, onsite and offsite vehicles) is predicted to be a maximum of 0.3 µg/m<sup>3</sup>. This represents an increase of 0.4% when compared to current background concentrations.

Dust deposition rates are expected to vary between an annual average of less than 10 mg/m<sup>2</sup>/day to a maximum of approximately 132 mg/m<sup>2</sup>/day. It is therefore recommended that measures are incorporated to minimise dust generation including:

- Limiting of vehicle speeds on unsurfaced roads;
- Minimise use of unsurfaced roads where possible;
- Where unsurfaced, the main access routes will be created using compacted well graded granular fill, appropriately designed to ensure good drainage to minimise the potential for erosion;
- Construction activities shall be suspended if excessive dust arises and measures shall be taken to control ground prior to resuming activities; and
- Consider using an additive (used in preference to untreated water) to be applied to non sealed roads, disturbed land and spoil piles to reduce dust generation.

These measures are considered appropriate to minimise dust to acceptable levels. However, a Community Interaction and Social Impact Management Plan should be implemented and maintained as a mechanism of communicating with the community (particularly to communicate when particularly dusty activities are planned) and responding to community grievances

---

<sup>2</sup> The traditional Azeri limit for NO<sub>2</sub> is the same as the annual average project limit value of 40µg/m<sup>3</sup>

## Units and Abbreviations

Unit	Description
°C	Degrees Celsius
µm	Micron
g/s	Grams per second
µg/m <sup>2</sup> /s	Micrograms per square metre per second
g/m <sup>2</sup> /s	Grams per square metre per second
µg/m <sup>3</sup>	Micrograms per cubic metre
g/KW-hour	Grams per Kilowatt hour
m	Metre
km	Kilometre
kW	Kilowatts
M	Meters
m/s	Meters per second
M <sup>3</sup>	Cubic metres
%	Percent
%ile	Percentile

Abbreviation/ Acronym	Description
ADMS	Atmospheric Dispersal Modelling System
AERMOD	American Meteorological Society/Environmental Protection Agency Regulatory Model
CERC	Cambridge Environmental Research Consultants
DMRB	Design Manual for Roads and Bridges
EHS	Environmental Health and Safety
EMEP	Environmental Monitoring, Evaluation, and Protection (programme)
EU	European Union
ISCST	Industrial Source Complex Short Term
IFC	International Finance Corporation
NO	Nitric oxide
NO <sub>2</sub>	Nitrogen dioxide
NO <sub>x</sub>	Oxides of nitrogen
OH	Hydroxyl
O <sub>3</sub>	Ozone

PM	Particulate matter
SD	Shah Deniz
SO <sub>2</sub>	Sulphur dioxide
UK	United Kingdom
US	United States
US EPA	United States Environmental Protection Agency
UV	Ultra violet
WHO	World Health Organisation

## 1. INTRODUCTION

This report presents the findings of a screening assessment of predicted atmospheric emissions associated with the construction of the Shah Deniz 2 (SD2) Infrastructure Project.

The SD2 Infrastructure Project includes the works required prior to the construction, installation, commissioning and operation of the onshore SD2 facilities within the SD2 Expansion Area at the Sangachal Terminal.

The key components of the SD2 Infrastructure Project (refer to Figure 1) are:

- Temporary reinstatement of the Early Oil Project Terminal access road;
- New access road from the Baku-Alyat Highway to the Terminal (and associated facilities);
- Clearance of the SD2 Project expansion area, located immediately to the west of the existing Terminal site;
- Site terracing;
- Construction and fit out of the construction camp and construction facilities;
- Installation and operation of a sewage treatment plant;
- Installation of storm water drainage and surface water/flood protection berms; and
- Beach pull / landfall area levelling.

### 1.1 Scope

This report comprises an assessment of the contribution from the following to key pollutant concentrations at sensitive receptors:

- Dust due to earth moving and construction activities;
- Exhaust emissions from onsite construction plant; and
- Exhaust emissions arising from offsite road traffic movements associated with the SD2 Infrastructure Project.

The pollutant species and averaging periods modelled have been based on the applicable air quality limit values set for the protection of human health, as presented in Section 2.1 of this report, and dust nuisance guidance.



Figure 1: Location of SD2 Infrastructure Project

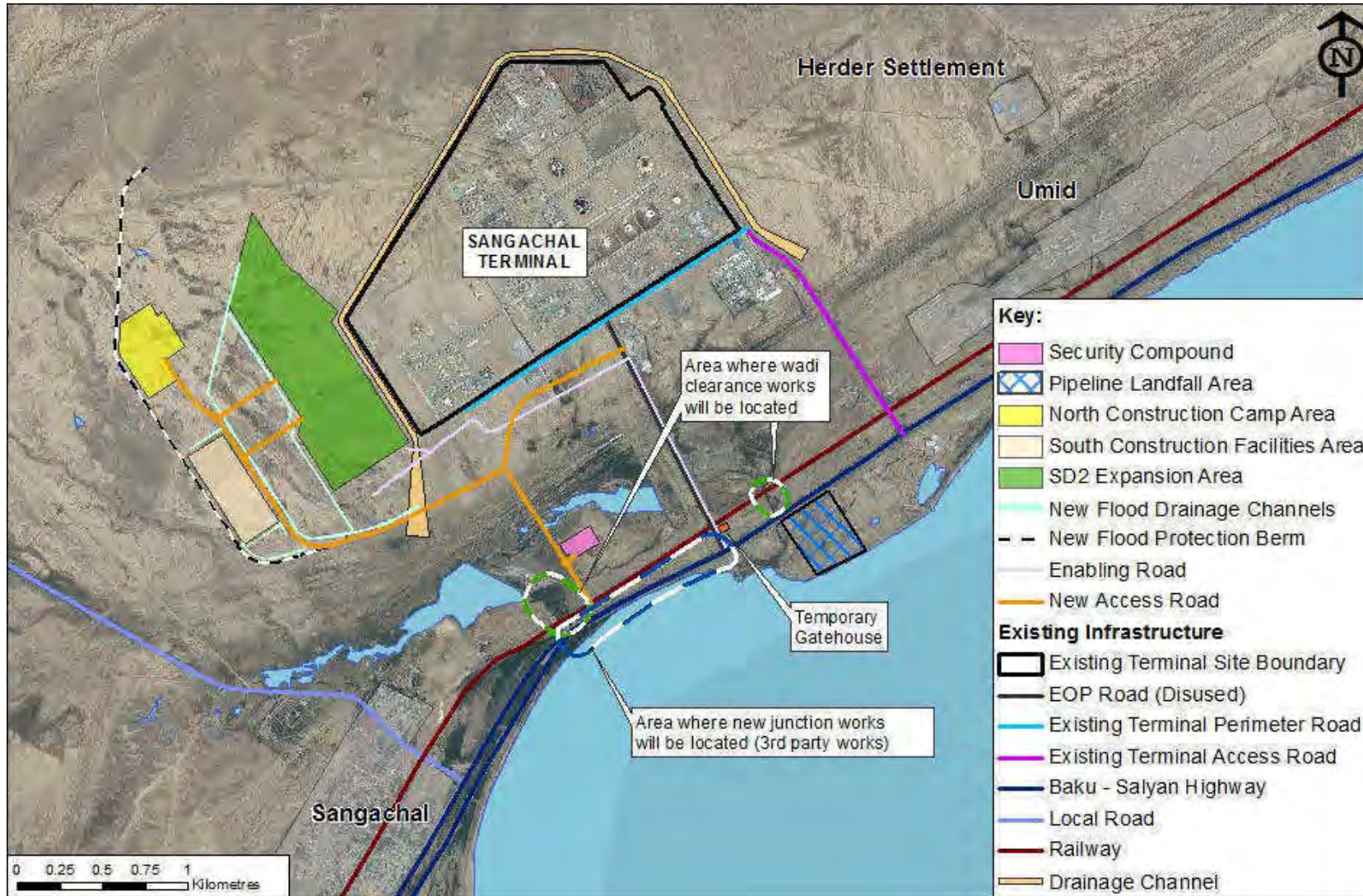



## 2. METHODOLOGY

The following steps have been followed to undertake the assessment:

1. Define applicable air quality limit values, dust nuisance guideline values and associated averaging periods;
2. Select a suitable atmospheric dispersion model or screening tool;
3. Determine the model input parameters, which for area sources includes:
  - Release height of the source,
  - Exit gas velocity,
  - Exit gas temperature,
  - Emission rate; and
  - Meteorological conditions.

And for road sources includes:

- Daily average traffic flows (SD2 Infrastructure Project traffic only);
  - Road type; and
  - Average vehicle speed.
4. Define dimensions of modelling grid and/or location of sensitive receptors;
  5. Define background pollutant concentrations receptors;
  6. Undertake the modelling/screening exercise; and
  7. Compare the modelled pollutant concentrations (including background concentrations) against the applicable air quality limit values to identify potential air quality impacts.

### 2.1 Air Quality Limits and Other Study Pollutants

#### 2.1.1. Air Quality Limit Values

Ambient air quality limit values are defined by the World Health Organisation (WHO) and European Union (EU) based on scientific knowledge with the aim of avoiding, preventing or reducing harmful effects to human health and/or the environment as a whole.

Each limit value is presented for a given averaging period, based on scientific knowledge of known toxicity to human health. Certain limit values are allowed a certain number of exceedances per calendar year, which corresponds to a particular 'percentile'.

The key pollutants that have been assessed in this study (associated with dust and combustion plant source emissions) are described as follows<sup>3</sup>:

- **Fine Particulate matter (PM<sub>10</sub>)** – PM<sub>10</sub> is defined as particulate matter with an aerodynamic diameter of less than 10 microns and is the result of a combination of man-made and natural processes, such as fossil fuel combustion, construction works or earth moving activities, and the natural entrainment of particles by the wind during periods of extended dry weather for example. In semi-arid and arid locations ambient PM<sub>10</sub> concentrations can exceed the international air quality standards regardless of the presence of local man-made activities (due to the un-vegetated and exposed soils). Exposure to increased levels of PM<sub>10</sub> are consistently associated with respiratory and cardiovascular illness and mortality; and
- **Nitrogen dioxide (NO<sub>2</sub>)**: Oxides of nitrogen (NO<sub>x</sub>) are formed as a by-product of the high temperature combustion of fossil fuels (such as natural gas) by the oxidation of nitrogen in the air. NO<sub>x</sub> primarily comprises of nitrogen oxide (NO), but also contains NO<sub>2</sub>; once emitted the former can be oxidised in the atmosphere to produce further NO<sub>2</sub>. It is the NO<sub>2</sub> that is associated with the health impacts, and at high concentrations it can affect lung function and airway responsiveness, and increase the risk of asthma and mortality. The rate of conversion of NO<sub>x</sub> to NO<sub>2</sub> in the atmosphere is discussed further in Section 2.4 of this report.

Project limit values exist for sulphur dioxide (SO<sub>2</sub>) however this pollutant species has not been assessed for site plant or offsite road traffic, because of the relatively low sulphur content of vehicle fuel in Azerbaijan. Diesel fuel in Azerbaijan currently has to comply with the 'GOST 305-82' regulations, which requires a maximum sulphur content of 0.2% (reducing to 0.1% by 2015) (Ref. 1). Based on this level of sulphur, and according to emission factors provided by the International Association of Oil and Gas Producers (OGP) (Ref. 2), NO<sub>x</sub> emissions are expected to be 9.5 times higher from construction and offsite road vehicles than SO<sub>2</sub>. Given that the project air quality limit values for SO<sub>2</sub> and NO<sub>2</sub> (which forms part of NO<sub>x</sub>) are similar<sup>4</sup>, it was not considered necessary to assess SO<sub>2</sub> emissions.

Table 1 summarises the ambient air quality limit values and averaging periods which have been adopted for the SD2 Infrastructure Project and provided in the SD2 Environmental Basis of Design (Ref. 3).

---

<sup>3</sup> While air quality limit values exist for CO, this species has been omitted from the assessment as the air quality limit value is more than 50 times that of NO<sub>x</sub>, but yet the emissions of these two pollutants from construction activities are of a similar magnitude.

<sup>4</sup> The mean annual limit values for NO<sub>2</sub> and SO<sub>2</sub> are 40 µg/m<sup>3</sup> and 50 µg/m<sup>3</sup> respectively. The 1 hour limit values for NO<sub>2</sub> and SO<sub>2</sub> are 200 µg/m<sup>3</sup> and 350 µg/m<sup>3</sup> respectively. SO<sub>2</sub> also has a daily and 10 minute limit value.

**Table 1: Ambient Air Quality Limit Values – NO<sub>2</sub> and PM<sub>10</sub>**

Pollutant Species	Air Quality Limit (µg/m <sup>3</sup> )	Averaging Period
NO <sub>2</sub>	40	Annual
	200	1 hour
PM <sub>10</sub>	50	24 hours (99 <sup>th</sup> percentile)
	20	Annual

These limit values apply to locations where members of the public are generally expected to be normally present (e.g. residential areas, schools, hospitals). They do not apply to work premises such as within the Sangachal Terminal, which is subject to less stringent workplace limits. Occupational and workplace exposure is not assessed within this report.

Historically in Azerbaijan ambient concentrations of NO<sub>2</sub> and PM<sub>10</sub> have also been assessed against specific 24 hour and 1 hour standards. These standards were not derived using the same health based criteria as the IFC, WHO and EU guideline values and the standards derived are not widely recognised. For completeness the estimated NO<sub>2</sub> and PM<sub>10</sub> emissions associated with the SD2 Infrastructure Project activities have been compared to the historic Azeri standards. These are:

- NO<sub>2</sub> 24 hour average of 40 µg/m<sup>3</sup>; and
- PM<sub>10</sub> 1 hour average of 300 µg/m<sup>3</sup> and 24 hour average of 100 µg/m<sup>3</sup>.

### 2.1.2. Dust Nuisance Criteria

The term ‘dust’ refers to both suspended and deposited particulate matter up to 75 microns (µm) in diameter. Dust emissions have the potential to create a public nuisance, through deposition of dust e.g. on vehicles, window sills etc.

There are no international criteria for nuisance dust deposition or safe levels of airborne dust in the ambient air, with health criteria instead focusing on the PM<sub>10</sub> dust fraction as discussed above.

There are no statutory limits for nuisance dust provided by the EU, World Bank, or WHO, though guidance levels do exist in some countries. A report by Airshed Planning Professional Ltd in 2010 (Ref. 4) provides a literature review of guidance limits in various countries. The most stringent limit value provided is 133 milligrams per metre squared per day (mg/m<sup>2</sup>/day) (as an annual average), which is considered the onset of loss of amenity by the Government of Western Australia State and the Argentine Government.

## 2.2 Model Selection

### 2.2.1. Earth Moving and Construction Activities and Onsite Plant

A range of models are available for atmospheric dispersion modelling, including Industrial Source Complex Short Term (ISCST), American Meteorological Society/Environmental Protection Agency Regulatory Model (AERMOD), and Atmospheric Dispersion Modelling System (ADMS).

This assessment has been undertaken using the UK Atmospheric Dispersion Modelling System, ADMS4 (version 4.2). This is a detailed dispersion model developed by Cambridge Environmental Research Consultants (CERC), which can also be applied to screening assessments.

Further details on model validity are provided in Annex A of this report and an extensive library of ADMS validation reports is available at: <http://www.cerc.co.uk/software/publications.html>.

Reasons for selection of ADMS4 are given as follows:

- ADMS-4.2 incorporates a superior basis for dispersion modelling, based on the Monin-Obhukov length parameter, rather than the Pasquill stability classes/Gaussian profiles used in earlier models. The systems in practice give similar results for stable and neutral atmospheric stability conditions, but, under unstable conditions, the predictions of models incorporating the Monin-Obhukov length are regarded as superior;
- The ADMS-4.2 model incorporates an integrated plume rise module, rather than the simple empirical formula used in ISCST and the basic AERMOD model. The empirical approach is known to give poor predictions of emissions from low release heights (such as dust release from construction works) as the equations were established primarily from the observations of large power station plumes;
- Many regulatory authorities explicitly endorse or accept the use of ADMS4. In the UK the Environment Agency does not formally “approve” any model (the UK Government’s open policy). However, ADMS is routinely used and approved by the Environment Agency of England and Wales, Scottish Environmental Protection Agency, and the Department of the Environment in Northern Ireland. ADMS is also used routinely on behalf of Department for Environment, Food and Rural Affairs (Defra), the UK Government department for the environment;
- ADMS is included in the United States Environmental Protection Agency’s Appendix W List of Alternative Models, and is approved for all types of environmental impact assessment in China. ADMS is an approved model in France, Italy, the Netherlands, Ireland, the Baltic States, South Africa, Hungary and Thailand and was used by the California Department of Health. The models are also used in Spain, Portugal, Sweden, Cyprus, Austria, United Arab Emirates, Sudan, Saudi Arabia, Tunisia, Slovenia, Poland, New Zealand, Korea, Japan, India, Canada and Australia;
- The model uses hourly sequential meteorological data to enable a realistic assessment of dispersion from point sources to be conducted; and
- ADMS has been rigorously validated by its manufacturers (CERC) against existing monitoring data and alternative models that are available. For the validation studies that were tested in simple terrain (which is considered to be the most similar to the study area), ADMS out performed these other models and

demonstrated a model accuracy to be within  $\pm 10\%$  of the actual monitoring findings.

### 2.2.2. Offsite Road Vehicles

A range of detailed and screening models exist for assessing the impacts of road vehicle emissions. Examples of screening tools include the Design Manual for Roads and Bridges (DMRB) screening tool, CAR-International, and CALINE 4. It was not considered necessary to use a detailed dispersion model such as ADMS-Roads to assess road traffic emissions given the relatively small increase in traffic flows expected on the local road network and absence of existing traffic data.

The Design Manual for Roads and Bridges (DMRB) Screening Method, version 1.03c (Ref. 5) was chosen for the assessment. This screening tool, published by the Highways Agency in England and Wales, and subsequently in Scotland and Northern Ireland, provides a method for estimating the impact of additional road traffic movements on local air quality.

The DMRB screening tool is based on UK emission limits and fleet composition. Since new vehicles in Azerbaijan are currently only required to meet 'EURO 2' emission limits, which was introduced to the UK in 1996 (Ref. 6), the year of assessment was set to 1996 in the screening tool.

## 2.3 Model Input Parameters

### 2.3.1. Earth Moving and Construction Activities

Significant atmospheric dust can arise from the mechanical disturbance of the ground. Dust generated from open sources is termed "fugitive" because it is not discharged to the atmosphere in a confined flow stream (such as emissions from a boiler flue).

The potential drift distance of airborne particles is governed by the initial injection height of the particle, the terminal settling velocity, and the degree of atmospheric turbulence. According to the United States Environmental Protection Agency (US EPA) document 'Fugitive Dust Sources' (Ref. 7), particles larger than about 100 microns ( $\mu\text{m}$ ) are likely to settle within 6 to 9 metres (m) from the emission source, with particles 30-100  $\mu\text{m}$  in diameter settling within 50-100m. Smaller particles, such as  $\text{PM}_{10}$ , can travel several hundreds of metres from the source, sometimes up to 1 kilometre (km).

It is difficult to provide an accurate prediction of dust and  $\text{PM}_{10}$  emissions associated with earth moving and construction activities, due largely to the uncertainty associated with estimating a reliable emission factor. Dust emissions can vary substantially from day to day depending on the level of activity, the specific operations and the prevailing meteorological conditions.

Despite this limitation, a screening exercise has been undertaken using the dispersion model ADMS4 (version 4.2), applying the parameters outlined in the US EPA document 'Fugitive Dust Sources' (Ref. 7).

The US EPA presents an emission rate for total suspended particles arising from heavy construction work of 2.69 tonnes per hectare per month of construction work (within a semi-arid climate with medium silt content). This corresponds to approximately 100 micrograms dust per square metre per second ( $\mu\text{g}/\text{m}^2/\text{s}$ ).

Furthermore, the US EPA report that, although dependent upon a variety of factors, such as soil type and soil moisture content, particles are unlikely to become entrained from undisturbed ground through the action of turbulent winds at speeds below 19km per hour (5.3 m/s). Wind speeds at the site are likely to exceed the aforementioned threshold for approximately 38% of the year, according to the 2007 meteorological data presented in Section 2.5 of this report. The emission factor is therefore likely to overestimate the actual impacts of dust emissions from the construction works.

An emission rate of  $20\mu\text{g}/\text{m}^2/\text{s}$  (or  $0.00002\text{g}/\text{m}^2/\text{s}$ ) was utilised to determine the effect on  $\text{PM}_{10}$  concentrations at specified receptor points. This is based on the U.K. approach which draws on research by the Quality of Urban Air Review Group (Ref. 8), which states that 20% of the airborne particles from construction activities tend to be of the size fraction  $\text{PM}_{10}$  and below.

Table 2 presents the parameters inputted into the ADMS4 model. It is considered that mobilisation of dust will be greatest during site preparation and earthworks, and therefore windblown dust from soil stockpiles and exposed areas of soil has not been modelled. Based on Chapter 5 of the SD2 Infrastructure Project ESIA, the most significant site preparation and earthworks will take place within the central part of the SD2 Infrastructure Area. This is estimated to be approximately 140 hectares and has been entered into ADMS4 as an area source.

**Table 2: Construction Dust Model Input Parameters**

Parameter	Value
Source type	Area source
Height of release above ground level	1m
Velocity of release	5m/s
Temperature of release	Ambient
Vertices	368589, 4451280 367928, 4452278 369023, 4452884 369573, 4451900
Emission rate for $\text{PM}_{10}$	$0.00002\text{g}/\text{m}^2/\text{s}$ during working hours
Emission rate for Dust	$0.0001\text{g}/\text{m}^2/\text{s}$ during working hours

It has been assumed that project activities will be limited to working hours, which will be 7am – 7pm Monday - Saturday.

### 2.3.2. Onsite Construction Plant

Table 3 presents the estimated number of plant operating onsite each day during the peak month of activity, which is anticipated to occur between January and September

2012 (based on Figure 5.4 and Table 5.4 Chapter 5: Project Description, which present the anticipated phasing and number and type of site plant for each phase respectively).

Table 3 also includes the estimated power rating of each plant (based on a review of manufacturer data) and expected NO<sub>x</sub> emissions, which is derived from an emission factor of 14.4 grams per kilowatt-hour (g/KW-hour) from the EMEP/CORINAIR Emission Inventory Guidebook (Ref. 9) for uncontrolled diesel powered site plant.

**Table 3: Estimated Number of Site Plant and NO<sub>x</sub> Emissions during Peak Construction**

Unit	Estimated Rating (kW)	NO <sub>x</sub> Emissions per unit (g/s)	No. plant in peak activity	NO <sub>x</sub> Emissions (g/s)
Bull Dozer	530	2.12	18	38.2
Wheeled Loader	25	0.10	15	1.5
Tracked Excavator	27	0.11	15	1.6
Dump Truck	25	0.10	114	11.4
Motor Grader	25	0.10	10	1.0
Sheep foot roller	10	0.04	9	0.4
Road Roller	13	0.05	3	0.2
Asphalt Paver	130	0.52	3	1.6
Road Lorry	25	0.10	95	9.5
Diesel Generator	100	0.40	30	12.0
Mechanical Water Bowser	25	0.10	30	3.0
Tracked Mobile Crane	115	0.46	9	4.1
Mobile Telescopic Crane	25	0.10	7	0.7
Earthworks Compactor	10	0.04	21	0.8
Concrete Mixer	1.5	0.01	8	0.0
Fork Lift Trucks	5	0.02	10	0.2
Water Pump	20	0.08	15	1.2
Concrete Pump	75	0.30	8	2.4
Air Compressor	7.5	0.03	7	0.2
Backhoe loader	10	0.04	7	0.3
Welding Set	50	0.20	8	1.6
Compactor Plate	6	0.02	12	0.3
JCB Tractor	200	0.80	10	8.0
Tilting Drum Mixer	5	0.02	7	0.1
Fuel Bowser	20	0.08	4	0.3
<b>TOTAL</b>	-	-	<b>475</b>	<b>100.6</b>

The total estimated release rate for NO<sub>x</sub> from the construction site plant is 100.6 g/s.

The working hours will be 7am – 7pm Monday to Saturday.



Table 4 presents the parameters inputted into the ADMS4 model, based on a working area of 140 hectares (representative of the central section of the SD2 Infrastructure Area) which has been entered into ADMS4 as an area source.

**Table 4: Site Plant Model Input Parameters**

Parameter	Value
Source type	Area source
Height of release above ground level	2m
Velocity of release	5m/s
Temperature of release	100°C
Vertices	368589, 4451280 367928, 4452278 369023, 4452884 369573, 4451900
Emission rate for NO <sub>x</sub>	0.00007g/m <sup>2</sup> /s during working hours

PM<sub>10</sub> emissions from onsite plant have not been included within the ADMS4 model. These are estimated to be a factor of 10 times less than NO<sub>x</sub> emissions and are expected to be indiscernible in comparison with the PM<sub>10</sub> emissions generated during earth moving and construction activities (Ref. 9).

### 2.3.3. Offsite Road Vehicles

In order to assess the predicted impact attributed to additional road traffic flows associated with the SD2 Infrastructure Project, a screening exercise has been undertaken using the DMRB Screening Method, version 1.03c.

In the absence of existing traffic flow data for the Highway, the screening assessment has focused on the predicted change due to the additional traffic due to the project, rather than absolute concentrations.

Table 5 presents the estimated number of daily 2-way offsite road vehicle movements (i.e. 1 arrival and departure equates to 2 movements) associated with the SD2 Infrastructure Project<sup>5</sup>.

The greatest increase in traffic flows is expected to occur between May and October 2013, with an estimated 162 vehicle movements per day. The low loader, road lorry and 7.5 tonne flat bed vehicle represent approximately 20% of the vehicle movements, and have been classed as Heavy Duty Vehicles in the DMRB screening tool. The remaining vehicles (minibus, 4x4 truck and private car) have been classed as Light Duty Vehicles, which are less than 3.5 tonne in weight.

It has been assumed that 100% of all vehicles will be travelling on the Baku Salyan Highway either to the west or east<sup>6</sup>.

<sup>5</sup> Derived from Table 5.5, Chapter 5: Project Description

**Table 5: Offsite Road Vehicle Movements**

Vehicle Type	2-way Daily Movements				
	Jan-Feb 2012	Mar-Apr 2012	May-Oct 2012	Nov 2012 - May 2013	Jun 2013
Low loader	2	6	2	2	0
Road lorry 25 tonnes	2	4	40	4	0
Minibus (18-20 seater)	6	30	60	60	6
7.5 tonne flat bed	2	4	4	4	0
4x4 pickup truck	8	16	16	16	8
Private car	10	40	40	40	20
<b>Total</b>	<b>30</b>	<b>100</b>	<b>162</b>	<b>126</b>	<b>34</b>

## 2.4 Conversion of NO<sub>x</sub> to NO<sub>2</sub>

At the point of release (from a combustion activity) NO<sub>x</sub> emissions predominantly comprise nitrous oxide (NO). However, NO converts to NO<sub>2</sub> in the free troposphere under influences of other gases such as ozone (O<sub>3</sub>) and hydroxyl (OH) compounds in the presence of UV radiation (in sunlight).

Since the focus of human health criteria is on NO<sub>2</sub> rather than NO<sub>x</sub>, it is important to determine a rate of conversion in the atmosphere, in order to calculate the ground level impact of NO<sub>2</sub>.

The Environment Agency for England and Wales's Horizontal Guidance Note (H1) on Assessment and Appraisal Best Available Technology (Ref. 10) presents the preferred conversion rates for NO<sub>x</sub> to NO<sub>2</sub>. It conservatively assumes that 100% of NO<sub>x</sub> converts to NO<sub>2</sub> in the long term (i.e. annual average), and 50% conversion for short term averaging periods (such as 1 hour and 24 hour).

Similarly, the United States Environmental Protection Agency (US EPA) recommends (in the absence of accurate monitoring data) a tiered approach for modelling NO<sub>2</sub> impacts (Ref. 11). The second tier uses the 'Ambient Ratio Method', which assumes that 75% of NO<sub>x</sub> is converted to NO<sub>2</sub> for the long term averaging period.

While ADMS4 includes a Chemistry Function which calculates NO<sub>2</sub> and NO<sub>x</sub> it was not considered appropriate to use for this study, as it requires accurate background ozone concentrations in order to calculate the convert NO<sub>x</sub> to NO<sub>2</sub> conversion. Ozone concentrations in the Terminal vicinity are not recorded. The DMRB screening tool also includes the ability to calculate NO<sub>2</sub> from NO<sub>x</sub>; however this is based on UK vehicle emissions data and has recently been dismissed by the U.K. Defra as underestimating actual NO<sub>2</sub> concentrations (Ref. 12).

The approach advocated in the Environment Agency for England and Wales's Horizontal Guidance Note (H1) has been chosen for this assessment. This is likely to provide an

---

<sup>6</sup> The direction of travel is not relevant within the model

overestimate for road traffic and site plant NO<sub>2</sub> emissions and hence provides a conservative assessment.

## 2.5 Meteorology

The dispersion of emissions from an area source is largely dependent on atmospheric stability and turbulent mixing in the atmosphere, which in turn are dependent on wind speed and direction, ambient temperature, cloud cover and the friction created by local terrain.

The meteorological data used in the dispersion modelling (including sunlight, temperature and wind data) was based on the available measurements made at Sangachal Terminal and supplemented by data from Baku Airport for the year (2007) (Ref. 13) and is shown in Figure 2.

**Figure 2: Wind-Rose (Sangachal Terminal) 2007**

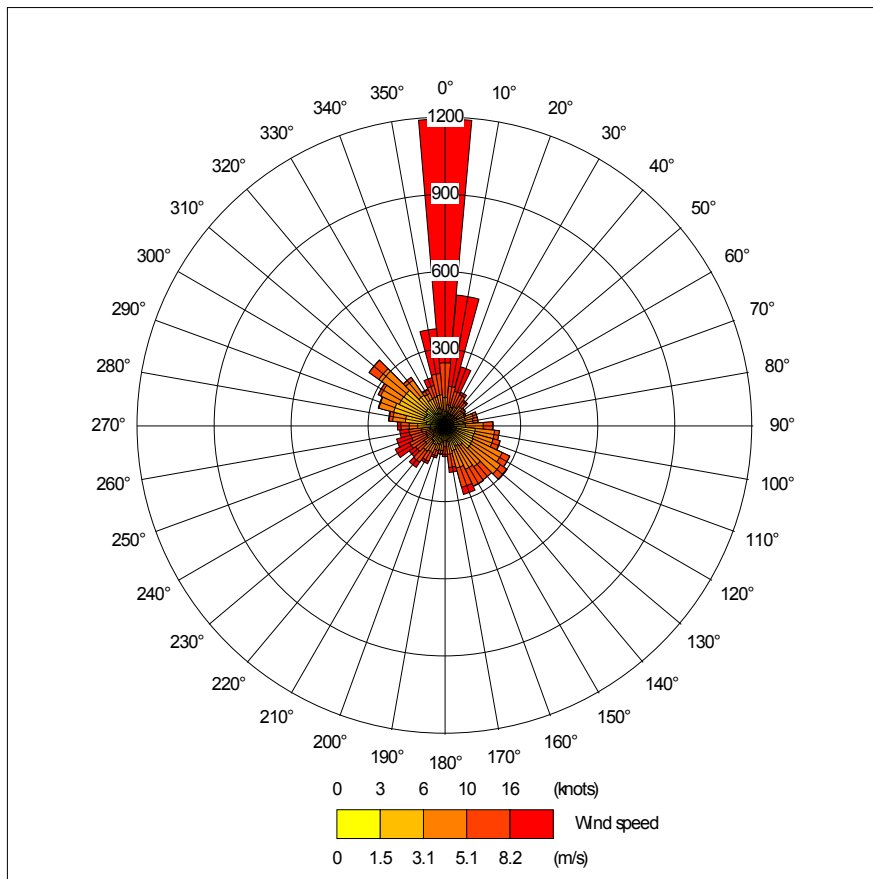

The DMRB Screening tool does not require meteorological data to be inputted. This is not considered a limitation to the assessment since road traffic emissions are affected less by changes in meteorological conditions than stationary combustion plant such as boilers due to their lower height of release and therefore more localised impact.

## 2.6 Model Domain and Specified Receptors

### 2.6.1. Earth Moving and Construction Activities and Onsite Plant

For the assessment of dust emissions and site plant emissions, a two dimensional Cartesian grid system has been used based on the 'Pulkovo 1942' coordinate system, using the 'Krasovsky 1940 spheroid'. The 4km x 4km grid is centred on the SD2 Expansion Area, with 80 receptor points (resulting in a modelled concentration every 50m).

The effect of atmospheric emissions has been assessed at the following modelled sensitive receptor locations:

- **Receptor 1:** Azim Kend/Masiv 3 - Two small communities 2.5km from the northwest corner of the Terminal, and approximately 1.9km from the western edge of the SD2 Expansion Area and associated works. Receptor located at 366485, 4451525;
- **Receptor 2:** Sangachal Town - Nearest main town, 1.5km from the southwest corner of the Terminal perimeter, and 1.2km from the closest edge of SD2 Expansion Area and associated works. Receptor located at 369409, 4450500;
- **Receptor 3:** Umid - Located 1km from the southeast perimeter of the Terminal, and approximately 2.9km from the SD2 Expansion Area and associated works. Receptor located at 372433, 4452634; and
- **Receptor 4:** Herder Settlement – A herder settlement located 1.3km east of the Terminal and approximately 3.8km from the expansion area. Receptor located at 372954, 4453793.

The locations of these sensitive receptors are illustrated in Figure 3, along with the area source chosen to represent the construction works (i.e. a working area of 140 hectares in the central section of the SD2 Infrastructure Area).

Figure 3: Location of Sensitive Receptors and Source Area

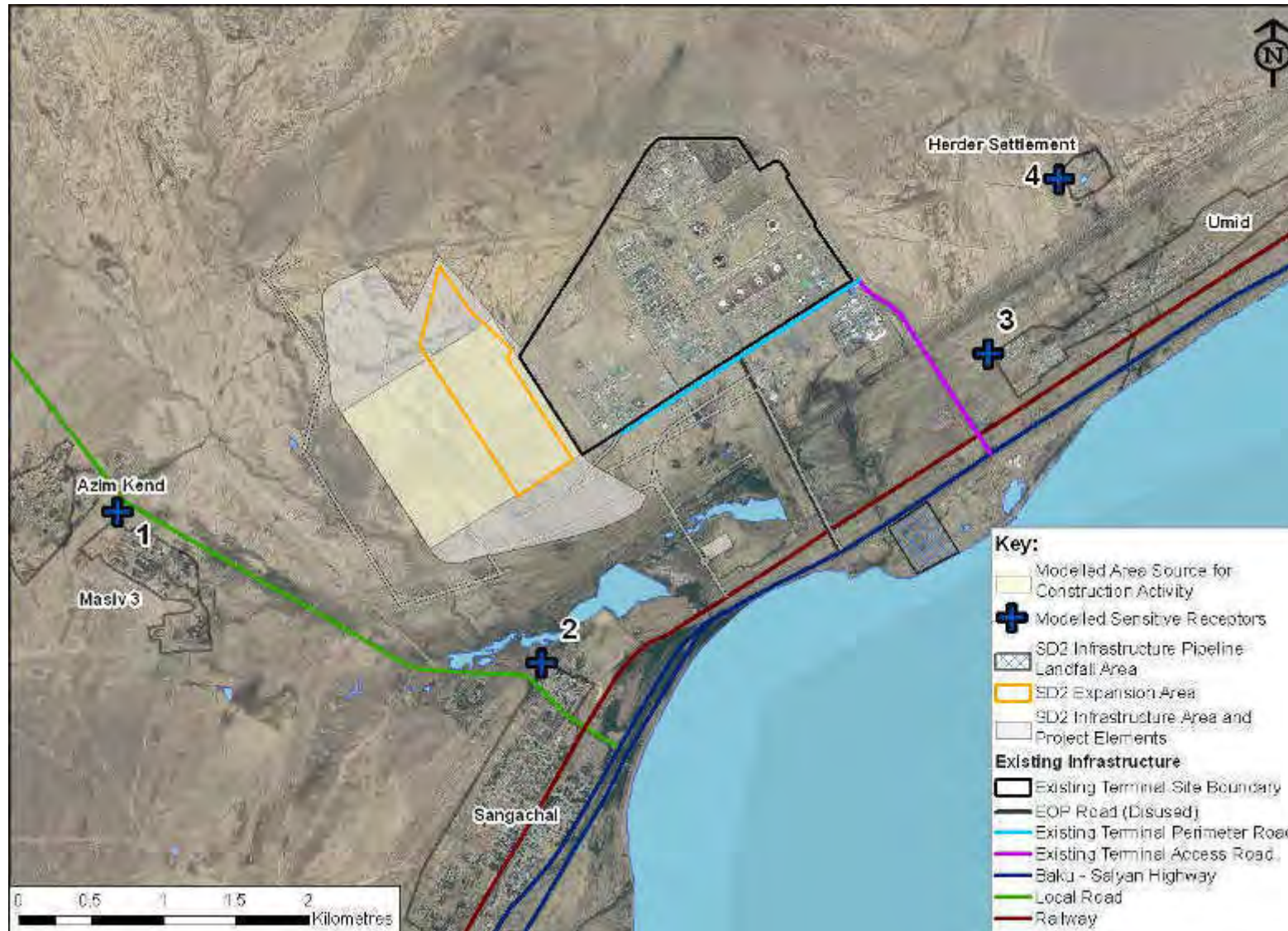



### 2.6.2. Offsite Road Traffic

For the assessment of road traffic emissions and impacts from construction traffic, associated with the project, a sensitive receptor location adjacent to the Baku-Salyan Highway in the south of the Sangachal Town, has been considered. It is understood this is the nearest receptor to the Highway, located approximately 20m north of the kerbside of the southbound Baku-Salyan Highway and 65m north of the northbound Baku-Alyat Highway, located at 369712, 4449629.

## 3. BASELINE CONCENTRATIONS

### 3.1 NO<sub>2</sub> and PM<sub>10</sub>

The background pollutant concentrations used in the assessment are presented in Table 6. These have been derived from the Sangachal Ambient Air Quality Monitoring Programme for 2010 (Ref. 14).

**Table 6: Background Pollutant Concentrations Used in the Assessment**

Pollutant	Mean Annual Concentrations
NO <sub>2</sub>	6 µg/m <sup>3</sup>
PM <sub>10</sub>	109 µg/m <sup>3</sup>

Concentrations of SO<sub>2</sub>, benzene, VOC and NO<sub>2</sub> were monitored at 17 locations using passive diffusion tubes. Hourly real-time monitoring data (for NO, NO<sub>2</sub>, NO<sub>x</sub>, SO<sub>2</sub> and PM<sub>10</sub>) was also collected at an automatic monitoring station (station AAQ23) between February - May 2009 and May – December 2010<sup>7</sup>.

Mean NO<sub>2</sub> concentrations ranged between approximately 2-6 µg/m<sup>3</sup> at background locations, increasing to 10-20 µg/m<sup>3</sup> at monitoring locations near the Terminal and within the communities, therefore easily complying with the mean annual limit value of 40µg/m<sup>3</sup>.

Ambient NO<sub>2</sub> concentrations recorded at the real-time monitoring station complied with the one hour average limit (200 µg/m<sup>3</sup>).

The average monthly PM<sub>10</sub> concentration in 2010 ranged between 33 µg/m<sup>3</sup> and 180 µg/m<sup>3</sup>, with considerable variance between the 9 months of monitoring. The average PM<sub>10</sub> concentration for the monitoring period was 109 µg/m<sup>3</sup>, which exceeds the annual average limit of 20 g/m<sup>3</sup>. In addition, PM<sub>10</sub> results exceeded the daily standard of 50 µg/m<sup>3</sup> during all but one month. This is likely to be predominantly due to natural processes such the exposed soils in the area leading to the natural entrainment of particles in the atmosphere.

<sup>7</sup> Interruptions to the monitoring station power supply prevented further data from being obtained.

### 3.2 Dust Deposition

Dust deposition rates are not currently monitored in the vicinity of the Terminal. However, data exists from other monitoring programmes that have been carried out in similar types of environments.

For example, a 15 year programme in China showed that the annual average rate of dust deposition in semi-arid areas ranges between 495 mg/m<sup>2</sup>/day and 896 mg/m<sup>2</sup>/day (Ref. 15).

Existing deposition rates from natural dust deposition are therefore likely to exceed the guidance limit value of 133 mg/m<sup>2</sup>/day.

## 4. SCREENING ASSESSMENT RESULTS

### 4.1 Earth Moving and Construction Activities

Table 7 presents a summary of the predicted increase in PM<sub>10</sub> concentrations from earth moving and construction activities at the modelled sensitive receptor locations.

**Table 7: Modelled Increase in PM<sub>10</sub> Concentrations due to Construction Activities (µg/m<sup>3</sup>)**

Pollutant	Receptor				Objective
	Azim Kend/ Masiv 3	Sangachal	Umid (east)	Umid (west)	
	R1	R2	R3	R4	
Increase in mean annual PM <sub>10</sub>	0.1	0.3	0.1	0.1	20
Maximum Increase in daily PM <sub>10</sub> (99th Percentile)	1.1	3.0	1.4	1.9	50

**The predicted increase in mean annual PM<sub>10</sub> concentrations at the nearest sensitive receptors is expected to range between 0.1 and 0.3 µg/m<sup>3</sup>. This represents between 0.5% and 1.5% of the project limit value.**

The increase in daily PM<sub>10</sub> concentrations (modelled as the 99<sup>th</sup> percentile) is higher, due to the shorter averaging period associated with this limit value. There is predicted to be an increase in the daily PM<sub>10</sub> concentration of 1.1 - 3.0 µg/m<sup>3</sup> at the modelled nearby sensitive receptor locations. This represents between 2.2 and 6% of the project limit value and between 1.1 – 3% of the traditional Azeri 24 hour standard.

**The impact on PM<sub>10</sub> concentrations associated with earth moving and construction activities is considered insignificant, and would be imperceptible in comparison with the background PM<sub>10</sub> concentration of 109 µg/m<sup>3</sup>.**

The increase in daily PM<sub>10</sub> concentrations (modelled as the 100<sup>th</sup> percentile) is again even higher, due to the shorter averaging period associated with this limit value. There is



predicted to be an increase in the daily PM<sub>10</sub> concentration of 1.6 - 6.7 µg/m<sup>3</sup> at the modelled nearby sensitive receptor locations. This represents between 3.2 and 13.4% of the limit value and between 1.6 - 6.7% of the traditional Azeri 24 hour standard.

It should be noted the 100<sup>th</sup> percentile demonstrates worst-case deposition and should not be confused with the highest wind speed. While PM<sub>10</sub> and dust 'lifting' is generally increased by high wind speeds, dust deposition does not necessary correlate directly with lifting as deposition is influenced by rate of dispersion and dilution in the atmosphere. A sensitivity study was undertaken using the model for the short term (24 hour) case and it demonstrated that PM<sub>10</sub> concentrations at ground level were similar for winds speeds of 5 and 15m/s but higher (by a factor of approximately 5) for wind speeds between 7-8 m/s.

Figure 4 present isopleths showing the contribution of mean annual PM<sub>10</sub>. Figures 5 and 6 present isopleths showing the contribution of 24 hour PM<sub>10</sub>, modelled as the 99<sup>th</sup> and 100<sup>th</sup> percentile respectively, due to earth moving and construction activities.

**Figure 4: Mean Annual PM<sub>10</sub> Emissions due to Earth Moving and Construction**

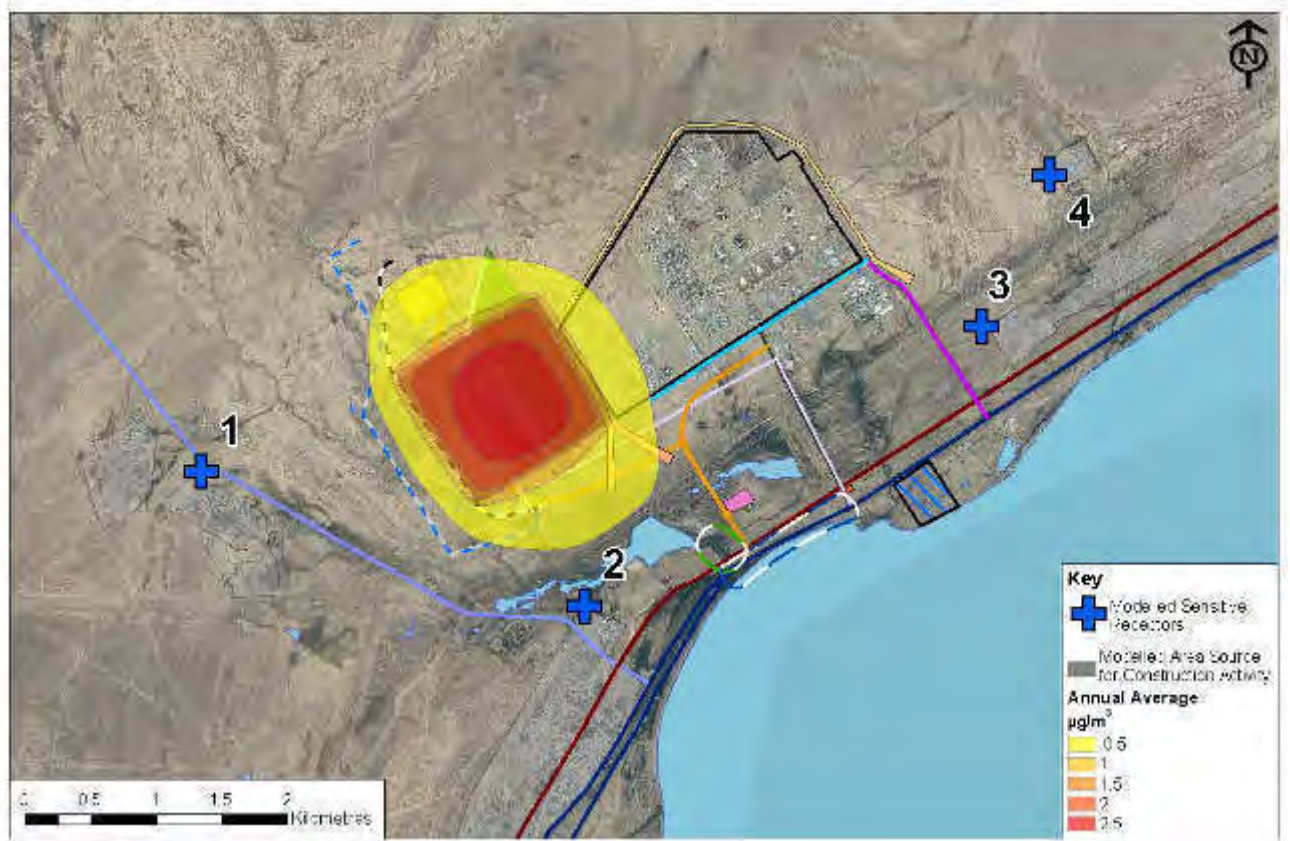

Figure 5: Modelled 99<sup>th</sup> Percentile 24-hour PM<sub>10</sub> Emissions due to Earth Moving and Construction

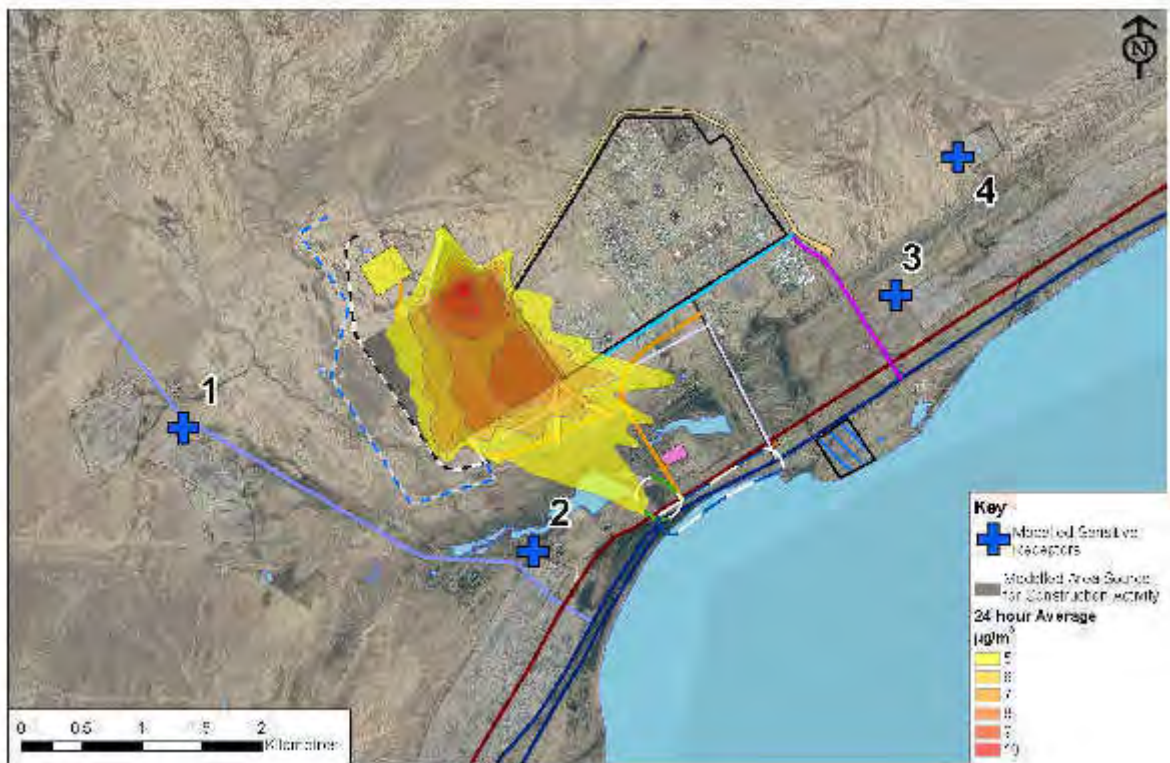
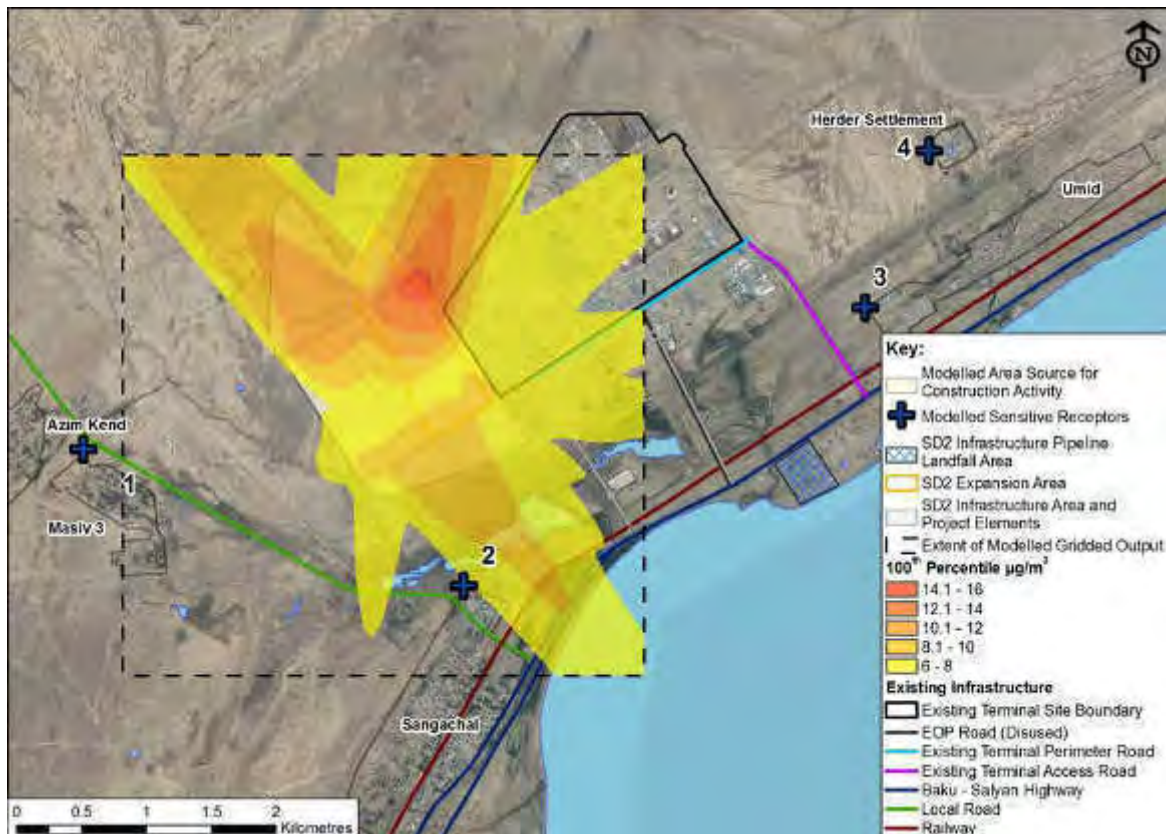

Figure 6: Modelled 100<sup>th</sup> Percentile 24-hour PM<sub>10</sub> Emissions due to Earth Moving and Construction





There are no internally agreed criteria against which to assess the potential for dust emissions arising from construction activities to cause a nuisance to nearby residents. There are. However, a number of guidance levels, the most stringent of which is known to be 133 mg/m<sup>2</sup>/day (refer to Section 2.1.2).

Table 8 presents the modelled rate of dust deposition that is predicted to occur at the nearest sensitive receptors due to earthmoving and construction activities as part of the SD2 Infrastructure Project.

**Table 8: Modelled Dust Deposition due to Construction Activities (mg/m<sup>2</sup>/day)**

Pollutant	Receptor				Guidance Limit
	Azim Kend/ Masiv 3	Sangachal	Umid (east)	Umid (west)	
	R1	R2	R3	R4	
Mean annual daily dust deposition rate	3.5	9.8	2	1.7	133
Maximum daily dust deposition rate <sup>1</sup>	31	132	115	51	133

<sup>1</sup> Calculated from the product of the 100<sup>th</sup> PM<sub>10</sub> percentile and the ratio of Mean Annual Dust to PM<sub>10</sub> deposition.

The maximum predicted rate of dust deposition offsite due to earth moving and construction activities is approximately 40 mg/m<sup>2</sup>/day, according to the ADMS4 model (based on annual mean). This occurs at the site boundary and represents approximately 30% of the guidance level.

The impact at the sensitive receptors is much less, ranging between 1.7 and 9.8 mg/m<sup>2</sup>/day. This represents 1.3 – 7.4% of the guidance level and is therefore considered imperceptible in comparison to the existing, background levels of dust deposition that generally occur in semi-arid areas.

The maximum (100<sup>th</sup> percentile) daily dust deposition rate, (i.e. the maximum daily rate during the entire metrological year) is estimated to range from 31-132 mg/m<sup>2</sup>/day. This represents 23 – 99% of the guidance levels, with worst case impacts identified at R2 (Sangachal). This does not take into account any mitigation applied to minimise dust generated on site.

## 4.2 Onsite Construction Plant

Table 9 presents a summary of the predicted impacts associated with onsite plant NO<sub>2</sub> emissions.

**Table 9: Modelled Change in NO<sub>2</sub> Concentrations due to Onsite Plant (µg/m<sup>3</sup>)**

Pollutant	Receptor				Objective
	Azim Kend/ Masiv 3	Sangachal	Umid (east)	Umid (west)	
	R1	R2	R3	R4	
Increase in Mean Annual NO <sub>2</sub>	<0.1	<0.1	<0.1	<0.1	40
Increase in 1-hour NO <sub>2</sub>	<0.1	<0.1	<0.1	<0.1	200

**There is predicted to be an increase in mean annual and 1 hour NO<sub>2</sub> concentrations at nearby receptor locations of less than 0.1 µg/m<sup>3</sup>. This represents less than 0.25% of the annual average NO<sub>2</sub> limit value and the traditional Azeri limit value and less 2% of the background NO<sub>2</sub> concentration.**

PM<sub>10</sub> emissions were not modelled, but given that they are expected to be approximately ten times less than NO<sub>x</sub> (see Section 2.3.2), they would also be imperceptible.

### 4.3 Offsite Road Vehicles

Table 10 presents the modelled change in mean annual NO<sub>2</sub> and PM<sub>10</sub> concentrations at the sensitive receptor location along the Baku Salyan Highway using the DMRB screening tool. The screening tool is not able to calculate the affect of emissions on the 1 hour NO<sub>2</sub> limit value; this is not considered a limitation, however, given that the mean annual limit value is generally considered to be the more stringent limit value (Ref. 16)<sup>8</sup>.

**Table 10: Modelled Change in Pollutant Concentrations due to the Offsite Road Vehicle Movements (µg/m<sup>3</sup>)**

Pollutant	Increase in Mean Annual Concentrations at Closest Sensitive Receptor	Air Quality Standard
NO <sub>2</sub>	0.9	40 µg/m <sup>3</sup>
PM <sub>10</sub>	0.2	40 µg/m <sup>3</sup>

**The modelled impact of the additional vehicle movements due to the SD2 Infrastructure Project is predicted to lead to an increase in mean annual NO<sub>x</sub> concentrations of 0.9µg/m<sup>3</sup> (at a receptor located 20m from Baku-Alyat Highway (Southbound) and 65m from Baku-Alyat Highway (Northbound)).** This is despite the conservative assumption that this level of traffic will continue for an entire calendar year. At a distance of 150m from the Highway increases in NO<sub>x</sub> concentrations were predicted to be less than 0.1 µg/m<sup>3</sup>

<sup>8</sup> Research in the UK has shown that mean annual NO<sub>2</sub> concentrations have to be at least 150% of the limit value before an exceedance of the 1 hour limit value is expected (Ref. 18).

It has been conservatively assumed that 100% of NO<sub>x</sub> converts to NO<sub>2</sub>, and therefore the impact on mean annual NO<sub>2</sub> concentrations is estimated to be 0.9µg/m<sup>3</sup>. **This represents 2.2% of the air quality project and traditional Azeri limit values for NO<sub>2</sub>, which is considered a negligible impact on local air quality.**

**The anticipated change to mean annual PM<sub>10</sub> concentrations is expected to be 0.1µg/m<sup>3</sup>.** This equates to 0.5% of the air quality project limit value (and 0.1% of the traditional Azeri limit value). This is also considered a negligible impact on local air quality, despite the background concentrations exceeding the air quality limit value. At a distance of 35m from the Highway increases in PM<sub>10</sub> concentrations were predicted to be less than 0.1 µg/m<sup>3</sup>

## 5. CONCLUSIONS

The results of the modelling undertaken are presented in Table 11.

**Table 11: Summary of the Modelled Impacts due to the SD2 Infrastructure Project**

Activity	Modelled Increase at Receptors <sup>1</sup>			Increase as % of relevant limit/guidance value <sup>2</sup>		
	NO <sub>2</sub> concentration (µg/m <sup>3</sup> )	PM <sub>10</sub> concentration (µg/m <sup>3</sup> )	Dust deposition (mg/m <sup>2</sup> /day)	NO <sub>2</sub>	PM <sub>10</sub>	Dust deposition
Earth moving and construction activities	NA	0.1 - 0.3	1.7 – 9.8	NA	0.5 – 1.5%	1.3 – 7.4%
Construction site plant exhaust emissions	<0.1	<0.1	NA	NA	NA	NA
Road traffic emissions	0.9	0.2	NA	2.2%	1%	NA
<b>Cumulative effect of all activities</b>	<b>0.9</b>	<b>0.3 - 0.5</b>	<b>1.7-9.8</b>	<b>2.2%</b>	<b>1.5 – 2.5%</b>	<b>1.3 – 7.4%</b>

Notes:

1. NO<sub>2</sub> and PM<sub>10</sub> background concentrations are 6 and 109µg/m<sup>3</sup>, respectively as determined from 2010 air quality monitoring report.
2. NO<sub>2</sub> annual average limit value = 40µg/m<sup>3</sup> PM<sub>10</sub> annual average limit value = 20µg/m<sup>3</sup>, dust nuisance guideline = 133 mg/m<sup>2</sup>/day.

The findings of the screening assessment are:

- **PM<sub>10</sub> emissions (associated with construction dust)** – The modelling predicts a contribution of between 0.1 and 0.3 µg/m<sup>3</sup> to PM<sub>10</sub> concentrations at the receptors modelled from earth moving and construction activities. This constitutes 0.5 - 1.5% of the annual average PM<sub>10</sub> limit value (which is 20 µg/m<sup>3</sup>) and represents less than 0,1% of the traditional Azeri 24 hour limit value (100 µg/m<sup>3</sup>);
- **Dust deposition** - The results obtained at sensitive receptors shows that the maximum daily rate of deposition offsite due to earth moving and construction activities is predicted to be between 1.7 and 9.8 mg/m<sup>2</sup>/day (on an annual basis). This represents 1.3 – 7.4% of the guidance levels and would be imperceptible in comparison with background levels. The maximum worst case daily dust deposition rate was also modelled with the highest rate of 132 mg/m<sup>2</sup>/day estimated at Sangachal. This is comparable to the most stringent guidance value for dust deposition found in literature;

- **Onsite plant and equipment emissions (NO<sub>2</sub> emissions)** - The modelling predicts that exhaust emissions from onsite plant and equipment are anticipated to lead an increase of less than 0.1 µg/m<sup>3</sup> in NO<sub>2</sub> concentrations at modelled receptors;
- **Offsite road vehicle emissions (NO<sub>2</sub> and PM<sub>10</sub> emissions)** - A contribution of up to 0.9 µg/m<sup>3</sup> to NO<sub>2</sub> concentrations and less than 0.2 µg/m<sup>3</sup> to PM<sub>10</sub> concentrations is predicted at receptors 20m adjacent to the Highway when the anticipated SD2 Infrastructure Project traffic flows are modelled. This represents 2.2% of the air quality project limit value for NO<sub>2</sub> and 0.5% for PM<sub>10</sub>;
- **Overall contribution from SD2 Infrastructure Project activities (NO<sub>2</sub> and PM<sub>10</sub> emissions)** –The cumulative impact of construction site and plant and the road traffic activities on PM<sub>10</sub> concentration at nearby sensitive receptors is expected to be 0.1-0.3 µg/m<sup>3</sup>. The cumulative impact on NO<sub>2</sub> concentrations will vary across receptors. Nearer to the Highway the contribution to NO<sub>2</sub> concentrations is predicted to be a maximum of 0.9 µg/m<sup>3</sup>, within the communities both onsite plant and offsite vehicle emissions are predicted to lead to increase of less than 0.1 µg/m<sup>3</sup>; and
- **Compliance with applicable limit values** - When taking account of the existing background concentrations the predicted NO<sub>2</sub> concentrations easily comply with the applicable air quality limit values. This is not the case for PM<sub>10</sub>. This is because PM<sub>10</sub> background concentrations already exceed the applicable limit values - this is considered to be predominantly a consequence of the dusty nature of the region.

In summary, it is not expected that the project will cause any air quality limit values to be exceeded where concentrations currently comply with the limit values. Where limits are currently exceeded (i.e. PM<sub>10</sub>) the contribution from the project (from plant, earth moving activities, onsite and offsite vehicles) is predicted to be a maximum of 0.3 µg/m<sup>3</sup>. This represents an increase of 0.4% when compared to current background concentrations.

Dust deposition rates are expected to vary between an annual average of less than 10 mg/m<sup>2</sup>/day to a maximum of approximately 132 mg/m<sup>2</sup>/day. It is therefore recommended that measures are incorporated to minimise dust generation including:

- Limiting of vehicle speeds on unsurfaced roads;
- Minimise use of unsurfaced roads where possible;
- Where unsurfaced, the main access routes will be created using compacted well graded granular fill, appropriately designed to ensure good drainage to minimise the potential for erosion;
- Construction activities shall be suspended if excessive dust arises and measures shall be taken to control ground prior to resuming activities; and

- Consider applying water to non sealed roads, disturbed land and spoil piles to reduce dust generation.

These measures are considered appropriate to minimise dust to acceptable levels. However, a Community Interaction and Social Impact Management Plan should be implemented and maintained as a mechanism of communicating with the community (particularly to communicate when particularly dusty activities are planned) and responding to community grievances.



## 6. REFERENCES

- Ref. 1 Partnership for Clean Fuels and Vehicles and United Nations Environmental Programme (UNEP); Opening the Door to Cleaner Vehicles in Developing and Transition Countries: The Role of Low Sulphur Fuels. <http://www.unep.org/transport/pcf/PDF/SulphurReport.pdf>
- Ref. 2 International Association of Oil and Gas Producers (OGP) (1994); Methods for Estimating Atmospheric Emissions from E&P Operations.
- Ref. 3 BP Exploration (Shah Deniz) Limited (2011); Shah Deniz Stage 2 Project. Environmental Basis of Design. BP-SM222-EV-BOD-001-02
- Ref. 4 Airshed Planning professionals Ltd (2010); Qualitative Air Quality Impact Assessment for the proposed Extension of the Existing General Waste Disposal Site at the Tutuka Power Station (Report No. APP/10/ZIT-01 <http://www.eskom.co.za/content/Appendix%20J%20-%20Air%20Quality%20Report.pdf>
- Ref. 5 The Highways Agency, (2003); 'Design Manual for Roads and Bridges: Environmental Assessment,' Volume 11, Section 3: Air Quality.
- Ref. 6 Department for Environment, Food and Rural Affairs (Defra). Appendix 1 EU Emission Standards for Petrol Vehicles. [http://uk-air.defra.gov.uk/reports/cat15/0408171318\\_SIPhase1reportAppendix1Issue3.pdf](http://uk-air.defra.gov.uk/reports/cat15/0408171318_SIPhase1reportAppendix1Issue3.pdf)
- Ref. 7 United States Environmental Protection Agency (US EPA). AP 42, Fifth Edition Compilation of Air Pollutant Emission Factors, Volume 1: Stationary Point and Area Sources. Chapter 13.2 Fugitive Dust Sources.
- Ref. 8 Quality of Urban Air Review Group (QUARG) (1996); Airborne Particulate Matter in the United Kingdom.
- Ref. 9 EMEP/CORINAIR Emission Inventory Guidebook (2007); Group 8 Other Mobile Sources and Machinery. <http://www.eea.europa.eu/publications/EMEPCORINAIR5>
- Ref. 10 Environment Agency (2010); Horizontal Guidance Note H1 – Environmental Risk Assessment for Permits. <http://www.environment-agency.gov.uk/business/topics/permitting/36414.aspx>
- Ref. 11 United States Environmental Protection Agency (US EPA) Applicability of Appendix W Modeling Guidance for the 1-hour NO<sub>2</sub> National Ambient Air Quality Standard. [http://www.epa.gov/ttn/scram/ClarificationMemo\\_AppendixW\\_Hourly-NO2-NAAQS\\_FINAL\\_06-28-2010.pdf](http://www.epa.gov/ttn/scram/ClarificationMemo_AppendixW_Hourly-NO2-NAAQS_FINAL_06-28-2010.pdf)

- Ref. 12 Department for Environment, Food and Rural Affairs, (2010). Memo 'Background concentrations for future years'.
- Ref. 13 BP (2009); 2009 Sangachal Terminal Air Quality Modelling and Monitoring Comparison.
- Ref. 14 Akvamiljø Caspian (2011); Sangachal Ambient Air Quality Monitoring Programme 2010, Final report (AmC report 10709-R1)
- Ref. 15 Wanquan Ta and Tao Wang (2004); 'Measurements of dust deposition in arid and semi-arid regions, China', American Society of Civil Engineers (ASCE) pp. 1-10.
- Ref. 16 UK Department for Environment, Food and Rural Affairs, (2009), Local Air Quality Management Technical Guidance, LAQM.TG (09).

## **Annex A: ADMS Model Overview**

ADMS 4 is a practical, short range dispersion model that simulates a wide range of buoyant and passive releases to the atmosphere either individually or in combination. It is a new generation air dispersion model developed by Cambridge Environmental Research Consultants (CERC) in the UK, which means that the atmospheric boundary layer properties are characterised by two parameters rather than in terms of the single parameter Pasquill-Gifford class:

- the boundary layer depth, and
- the Monin-Obukhov length.

Dispersion under convective meteorological conditions uses a skewed Gaussian concentration distribution (shown by validation studies to be a better representation than a symmetrical Gaussian expression).

The model is applicable up to 60km downwind of the source and provides useful information for distances up to 100km.

**Table A1: The ADMS 4 model**

<b>Model options</b>	ADMS 4 has a number of model options including: dry and wet deposition; NOX chemistry; impacts of hills, variable roughness, buildings and coastlines; puffs; fluctuations; odours; radioactivity decay (and $\gamma$ -ray dose); condensed plume visibility; time varying sources and inclusion of background concentrations.
<b>Meteorological pre-processor</b>	ADMS 4 has an in-built meteorological pre-processor that allows flexible input meteorological data both standard and more specialist. Hourly sequential and statistical data can be processed, and all input and output meteorological variables are written to a file after processing.
<b>User-defined outputs</b>	The user defines the pollutant, averaging time (which may be an annual average or a shorter period), which percentiles and exceedence values to calculate, whether a rolling average is required or not and the output units. The output options are designed to be flexible to cater for the variety of air quality limits, which can vary from country to country, and are subject to revision.
<b>Visualisation</b>	ADMS 4 includes the ADMS Mapper: an integrated mapping tool for displaying and editing source data, buildings and receptor locations and viewing results. The model has links to the Surfer contour-plotting package, in addition to ArcGIS and MapInfo Professional Geographical Information System (GIS) software. The GIS links can be used to enter and display input data, and display output, usually as colour contour plots.

**Table A2: Comparison of ADMS versus other models**

	ADMS 4	AERMOD	ISC
<b>Meteorology</b>			
Meteorological pre-processor	✓	✓	✗
<b>Dispersion</b>			
Boundary-layer structure	h, L <sub>MO</sub> scaling	h, L <sub>MO</sub> scaling	Pasquill stability classes
Plume rise	Advanced integral model	Briggs empirical expressions	Briggs empirical expressions
Concentration distribution	Advanced Gaussian	Advanced Gaussian	Basic Gaussian
<b>Complex effects</b>			
Buildings	ADMS buildings module <sup>1</sup>	PRIME buildings module <sup>1</sup>	PRIME buildings module <sup>1</sup>
Complex terrain	Based on calculation of flow field and turbulence field by FLOWSTAR model	Interpolation between neutral flow approximate solution and stable flow impaction solution	Simple approach assuming plume trajectory unaffected by terrain
Deposition (wet and dry)	✓	✓	✓
Chemistry	Generic Reaction Set 8 reaction scheme	Ozone limiting model, assumes maximum conversion of NO to NO <sub>2</sub>	Ozone limiting model, assumes maximum conversion of NO to NO <sub>2</sub>
<b>Other options</b>			
Fluctuations	✓	✗	✗
Visible plumes	Condensed plume visibility	✗	✗
Radioactivity	Radioactive decay / γ-ray dose; decay chain database	Simple decay	Simple decay

	ADMS 4	AERMOD	ISC
Puff model	✓	✗	✗
Coastline module	✓	✗	✓
Input of vertical profiles of meteorological data	✓	✓	✗

<sup>1</sup> See A. Robins, 2000: *A discussion of the building modules in ADMS 3 and PRIME*





## **APPENDIX 9D**

### **Noise Screening Assessment**





**Shah Deniz 2 Infrastructure  
Project**

**Construction Noise  
Assessment**

13th July 2011

Issue No 1  
49316164/

**Project Title:** Shah Deniz 2 Infrastructure Project  
**Report Title:** Construction Noise Assessment  
**Project No:** 46369017  
**Report Ref:** n/a  
**Status:** Draft Report  
**Client Company Name:** BP Exploration (Shah Deniz) Ltd  
**Issued By:** URS Corporation Ltd

**Document Production / Approval Record**

Issue No:	Name	Signature	Date	Position
1				
Prepared by	Mark Rogers		July 2011	Lead Engineer, Acoustics
Checked by	Graham Cowling		July 2011	Principal Acoustics Consultant
Approved by	Anna Rouse		July 2011	Principal Consultant

**Document Revision Record**

Issue No	Date	Details of Revisions
1	13 <sup>th</sup> July 2011	Original report

## CONTENTS

<b>SECTION</b>	<b>PAGE NO</b>
Units and Abbreviations.....	5
<b>1. INTRODUCTION.....</b>	<b>7</b>
1.1 Scope .....	7
<b>2. METHODOLOGY.....</b>	<b>9</b>
2.1 Applicable Project Standards for Noise and Guidance .....	10
2.2 Model Input Parameters.....	12
2.3 Receptors .....	15
<b>3. BASELINE NOISE LEVELS.....</b>	<b>16</b>
<b>4. ASSESSMENT SCENARIOS.....</b>	<b>18</b>
4.1 Construction Plant Scenarios.....	18
4.2 Concrete Batching Plant .....	18
4.3 Piling Scenarios.....	19
4.4 Concrete Breaking Scenarios .....	19
4.5 Cumulative Scenarios .....	19
<b>5. SCREENING ASSESSMENT RESULTS.....</b>	<b>19</b>
5.1 Construction Plant (on-site).....	19
5.2 Concrete Batching Plant .....	26
5.3 Piling.....	26
5.4 Concrete Breaking.....	26
5.5 Cumulative Assessment.....	27
<b>6. CONCLUSIONS AND RECOMMENDATIONS.....</b>	<b>27</b>
<b>7. REFERENCES.....</b>	<b>32</b>
 <b>ANNEX A: RECEPTOR DISTANCES FROM CONSTRUCTION AREAS</b>	
 <b>ANNEX B: CONSTRUCTION NOISE CALCULATIONS (WORST-CASE SCENARIO – NO FLOOD PROTECTION BERM)</b>	
 <b>ANNEX C: CONSTRUCTION NOISE CALCULATIONS (REALISTIC SCENARIO – NO FLOOD PROTECTION BERM)</b>	
 <b>ANNEX D: PILING AND CONCRETE BREAKING NOISE CALCULATIONS</b>	

## **LIMITATION**

URS Corporation Limited (URS) has prepared this Report for the sole use of BP Exploration (Shah Deniz) Ltd in accordance with the Agreement under which our services were performed. No other warranty, expressed or implied, is made as to the professional advice included in this Report or any other services provided by us. This Report may not be relied upon by any other party without the prior and express written agreement of URS. Unless otherwise stated in this Report, the assessments made assume that the sites and facilities will continue to be used for their current purpose without significant change. The conclusions and recommendations contained in this Report are based upon information provided by others and upon the assumption that all relevant information has been provided by those parties from whom it has been requested. Information obtained from third parties has not been independently verified by URS, unless otherwise stated in the Report.

## **COPYRIGHT**

© This Report is the copyright of URS Corporation Limited. Any unauthorised reproduction or usage by any person other than the addressee is strictly prohibited.

## Units and Abbreviations

Unit	Description
dB	Decibel, unit of sound
dB(A)	A-weighted sound pressure level in decibels
Km	Kilometre
LAeq	The equivalent continuous A-weighted sound pressure level over a specific time period.
Lw	Sound power level in decibels
LA10	The noise level exceeded for 10% of the time, and normally attributable to a series of higher noise events such as road traffic
LA90	The noise level exceeded for 90% of time. Often referred to as the “background level” this value, particularly in the case of a steady continuous noise source (such as the terminal) can be used to indicate the steady noise level emitted by that source.
m	Metres
Abbreviation/ Acronym	Description
SD	Shah Deniz
UK	United Kingdom





## 1. INTRODUCTION

This report presents the findings of modelling assessments undertaken to estimate the expected noise levels due to the Shah Deniz Stage 2 (SD2) Infrastructure Project at sensitive receptors.

The SD2 Infrastructure Project includes the works required prior to the construction, installation, commissioning and operation of the onshore SD2 facilities within the SD2 Expansion Area at the Sangachal Terminal. The key components of the SD2 Infrastructure Project (refer to Figure 1) are:

- Temporary reinstatement of the Early Oil Project Terminal access road;
- New access road from the Baku-Alyat highway to the Sangachal terminal (and associated facilities);
- Clearance of the SD2 Project expansion area, located immediately to the west of the existing terminal site;
- Site terracing;
- Construction and fit out of the construction camp and construction facilities;
- Installation and operation of a sewage treatment plant;
- Installation of storm water drainage and surface water/flood protection berms; and
- Beach pull / landfall area levelling.

### 1.1 Scope

Assessments have been undertaken to evaluate the relative contribution levels of noise at sensitive receptors from the following sources:

- Construction plant (on-site);
- Concrete Batching Plant<sup>1</sup>;
- Off-site Road Traffic;
- Piling; and
- Concrete Breaking

A cumulative assessment of all construction activity has also been carried out for the most active period of construction. The predicted noise levels at sensitive receptors have been compared to the limits defined in Section 2.1 of this report.

---

<sup>1</sup> Not included with the project base case. Space has been allocated should this option be selected.

Figure 1: Location of SD2 Infrastructure Project

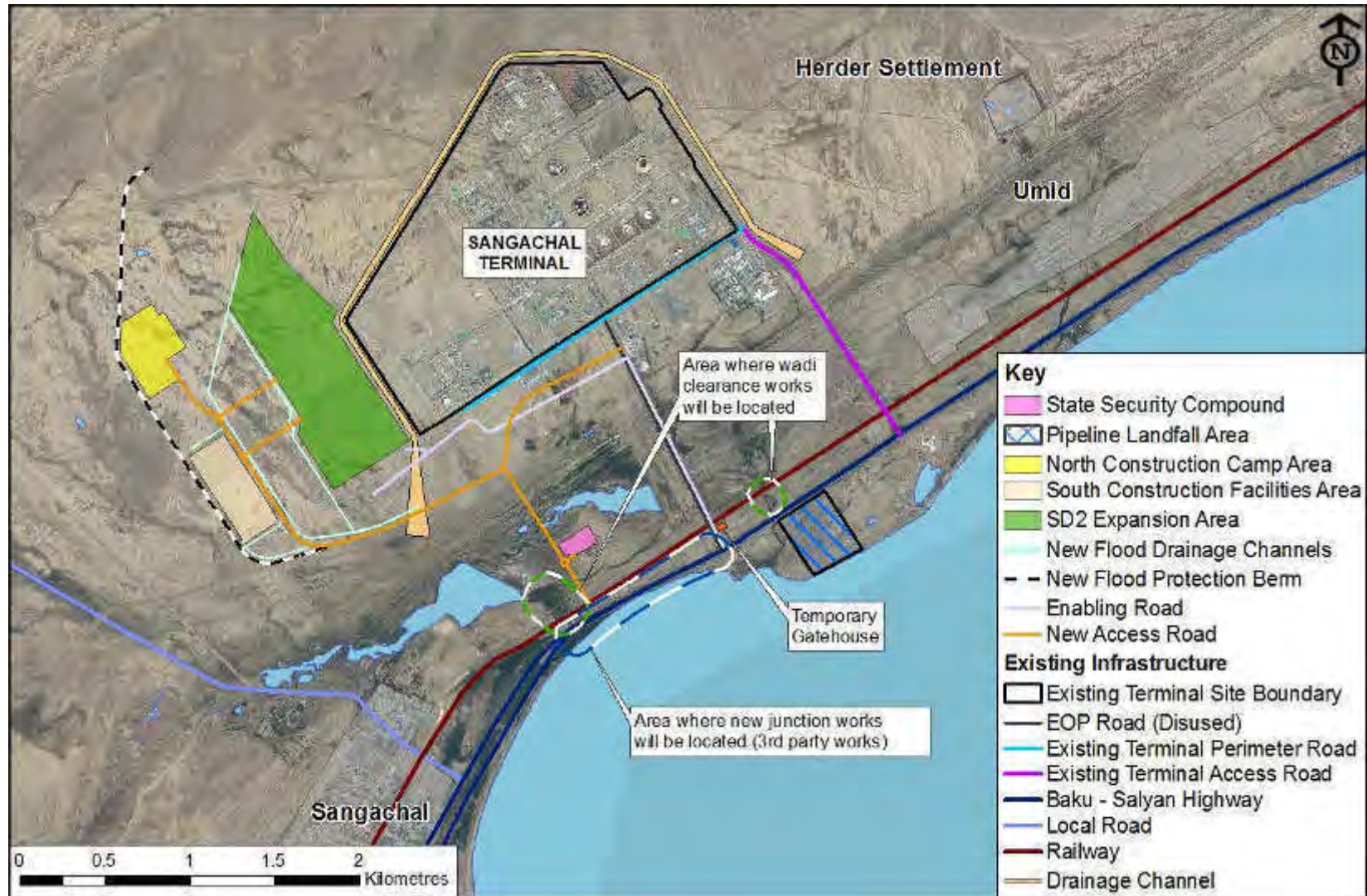

The SD2 Infrastructure Project is expected to commence in January 2012 with an expected duration of 18 months. The works will be undertaken in seven distinct phases (refer to Figure 2) as described within the SD2 Infrastructure ESIA Project Description chapter (Ref. 2).

**Figure 2: Indicative SD2 Infrastructure Project Schedule**

Phase	2012				2013	
	Q1	Q2	Q3	Q4	Q1	Q2
Phase 1 Set Up of Initial Site Compound	■					
Phase 2 Establishment of the Enabling Road and Power Diversion Works	■	■				
Phase 3 Site Preparation	■	■	■			
Phase 4 Main Civils Works		■	■	■	■	■
Phase 5 Earthwork Profiling			■	■		
Phase 6 Construction of Camps and Fit Out		■	■	■	■	
Phase 7 Closure of Enabling Road and at Grade Rail Crossings						■

## 2. METHODOLOGY

The following steps have been followed to undertake the construction noise assessment:

1. Review the SD2 Infrastructure Project ESIA Project Description (Chapter 5) (Ref. 2);
2. Review of applicable project standards and assessment criteria for construction noise and traffic noise;
3. Determine the requirement for traffic assessment in accordance with relevant guidance based on:
  - Current estimated traffic flows along the Baku-Salyan Highway; and
  - Predicted flows associated with the SD2 Infrastructure project.
4. Prepare a construction propagation modelling spreadsheet that predicts construction plant noise levels at noise sensitive receptors (refer to Annex B);
5. Determine the construction plant noise model input parameters which are:
  - The types and numbers of construction plant used and their associated noise generation levels from routine use;
  - Distances (in metres) between the sources of construction noise and locations of each noise sensitive receptor;

- The correction to be applied to reflect the presence of buildings (referred to as the façade correction factor);
6. Determine the construction noise model input parameters for the concrete batching plant including noise generation level, estimated usage and location relative to sensitive receptors;
  7. Determine the construction noise model input parameters for concrete breaking activities and a number of different piling scenarios, including piling type, estimated usage and location relative to sensitive receptors;
  8. Establish construction noise assessment scenarios based on:
    - The location of construction plant;
    - The estimated duration of use per day;
    - The level of attenuation by project elements (i.e. the proposed flood protection berm).
  9. Use the construction noise model to identify the contribution of noise from the on-site construction plant at receptors;
  10. Use the construction noise model to identify the contribution of noise from the Concrete Batching Plant at receptors;
  11. Determine noise levels at receptors associated with concrete breaking and piling activities;
  12. Determine overall construction noise at receptors assuming all activities occur simultaneously during the most active period on site; and
  13. Evaluate the need for, and type of, construction noise mitigation measures.

## 2.1 Applicable Project Standards for Noise and Guidance

### 2.1.1 Construction Plant

The assessment of construction noise is based on the guidance provided within British Standard BS5228:2009 *Code of practice for noise and vibration control on construction and open sites* (Ref. 3).

BS5228:2009 provides a number of methods to assess significance of construction noise. For this assessment the method adopted determines the potential acceptability of predicted noise levels based on absolute limit values, which take into account existing ambient noise levels. This is achieved by establishing different categories as follows:

- Category A noise limits – relevant when ambient noise levels are **less than** the limit values;

- Category B – relevant when ambient noise levels are **the same** as the Category A noise limits; and
- Category C - relevant when ambient noise levels are **greater than** the Category A noise limits.

The relevant noise limits are provided in Table 1 below.

**Table 1: BS5228:2009 Construction Noise Limits (dB LAeq)**

Period	Category A	Category B	Category C
Night-time (23:00 to 07:00)	45	50	55
Evening and weekends	55	60	65
Daytime (07:00 to 19:00) and Saturday (07:00 to 13:00)	65	70	75
Category A –when ambient noise levels are less than these values			
Category B –when ambient noise levels are the same as category A			
Category C –when ambient noise levels are higher than category A values			

Construction working hours are assumed, from the Project Description (Chapter 5) (Ref. 2), to be:

- 07:00 to 19:00 Monday to Saturday.

Based upon the working hours above and current baseline noise levels at receptors (see Section 3 below) the construction noise guideline level of 65 dB(A) is considered a suitable limit for the assessment of on-site construction plant, piling and concrete breaking activities.

### 2.1.2 Concrete Batching Plant

The concrete batching plant will be stationary source and it is assumed it will operate throughout the project (once installed). It is classified as construction plant and the construction guideline level of 65 dB(A) applies to noise generated by the plant operation.

### 2.1.3 Off-site Road Traffic

The UK Institute of Environmental Management and Assessment (IEMA) Guidance Note No. 1 (Ref. 4) provides relevant guidance with regard to when a traffic noise assessment should be undertaken. The Guidance Note states that an assessment should be completed when:

- a) Traffic flows will increase by more than 30%; or
- b) Where traffic flows (including Heavy Goods Vehicles (HGVs) at receptors sensitive to road traffic noise will increase by more than 10%.



It is estimated that traffic levels along the Baku-Salyan Highway are between 10,000 and 20,000 per day. Assuming that 10% of vehicles are HGVs (which is supported by observations made by URS during the 2010 baseline surveys- see Section 3 below) then the estimated daily number of HGVs is currently 1,000.

Chapter 5 of SD2 Infrastructure ESIA (Ref. 2) indicates that the estimated number of vehicles to use the Baku-Salyan Highway during the SD2 Infrastructure Project will peak between May 2012 and October 2012 at 162 vehicles per day (1.62% of the total traffic flow). IEMA Guidance Note No. 1 indicates that an increase in traffic flows that is less than 10% for noise sensitive locations then there will be no significant impacts associated with off-site road traffic.

According to the Design Manual for Roads and Bridges (Ref. 5), a 25% increase in HGV traffic flow results in an increase in noise levels of 1 dB(A). The estimated number of additional HGVs during the construction period is 4.6%. Therefore it is expected that noise levels at receptors due to construction traffic along the Highway will increase by no more than 1 dB(A) and no significant impacts associated with traffic noise are expected.

## 2.2 Model Input Parameters

### 2.2.1 Construction Plant

The types of construction plant expected to be used during the SD2 Infrastructure Project are provided in Chapter 5 (Section 5.7.1) of the SD2 Infrastructure ESIA (Ref. 2). Table 2 presents the sound levels generated from each item of machinery. The noise levels generated from each type of machinery are derived from BS5228:2009 Part 1 and are presented in dB(A) at a distance of 10m from the source.

**Table 2: Construction Plant Types and Sound Levels**

Plant Item	dB(A) at 10m	Reference from BS5228:2009 Part 1
Bull Dozer D6/D8/D9/D10	79	Table C2 Ref. 11
Wheeled Loader – 25t	79	Table C2 Ref. 26
Tracked Excavator – 27t	75	Table C4 Ref. 64
Dump Truck – 25t	85*	Table C6 Ref. 17
Motor Grader – 25t	86	Table C6 Ref. 31
Sheet Foot Roller/Vibro Roller – 10t	80*	Table C5 Ref. 19
Road Roller – 13t	80*	Table C5 Ref. 21
Asphalt Paver	77	Table C5 Ref. 31
Road Lorry – 25t	80	Table C6 Ref. 21
Diesel generator (50/100 kVA)	65	Table C6 Ref. 39
Mechanical Water Bowser	83*	Table C6 Ref. 38
Tracked Mobile Crane – 115t	75	Table C4 Ref. 52



Plant Item	dB(A) at 10m	Reference from BS5228:2009 Part 1
Mobile Telescopic Crane – 25t	82	Table C4 Ref. 45
Earthworks Compactor – 10t	73*	Table C2 Ref. 38
Concrete Mixer 200 litres	77	Table C4 Ref. 21
Fork Lift Trucks – 5t	79	Table C4 Ref. 54
Water Pump - 20kW	65	Table C2 Ref. 45
Concrete Pumps	78	Table C3 Ref. 25
Air Compressor – 8/20 m3/min	65	Table C5 Ref. 5
Backhoe Loader – 10t	67	Table C4 Ref.14
Welding Set	73	Table C3 Ref. 31
Compactor Plate	82	Table C5 Ref. 29
JCB Tractor	67	Table C4 Ref.14
Tilting Drum Mixer	61	Table C4 Ref. 23
Fuel Bowser	89*	Table C6 Ref. 36
* Maximum “pass-by” sound pressure level		

Using the project schedule (Figure 2) and the quantity of each type of construction plant in use during each of the seven phases, (refer to Chapter 5 (Table 5.4) of the SD2 Infrastructure ESIA (Ref. 2)) the quantity of each type of plant in use per month has been calculated.

### 2.2.2 Concrete Batching Plant

Based on information derived from concrete batching plant operations recorded from surveys completed in the UK, a noise level of 111 dB(A) Lw has been assumed for this facility. It is assumed that the concrete batching plant will be operational during daytime hours (07:00 – 19:00) only and will be located on the SW boundary of the SD2 Expansion Area.

### 2.2.3 Piling

The following piling activities are planned:

- Bored piling associated with installation of crossings under the new access road within the state pipeline corridor immediately to the south of the Terminal (refer to Chapter 5 Figure 5.8); and
- Piling trials either within or 100m from the boundary of the SD2 Expansion Area (refer to Chapter 5 Section 5.5.5).

It is assumed that the piling associated with the installation of the access road crossing will require 3 bored piling rigs; pneumatic hammers and an air compressor in Location 1 and Location 2 (see Figure 3). It is assumed that the rigs would be operational 100% of the day.

**Figure 3: Location of Piling Activities and Concrete Breaking**

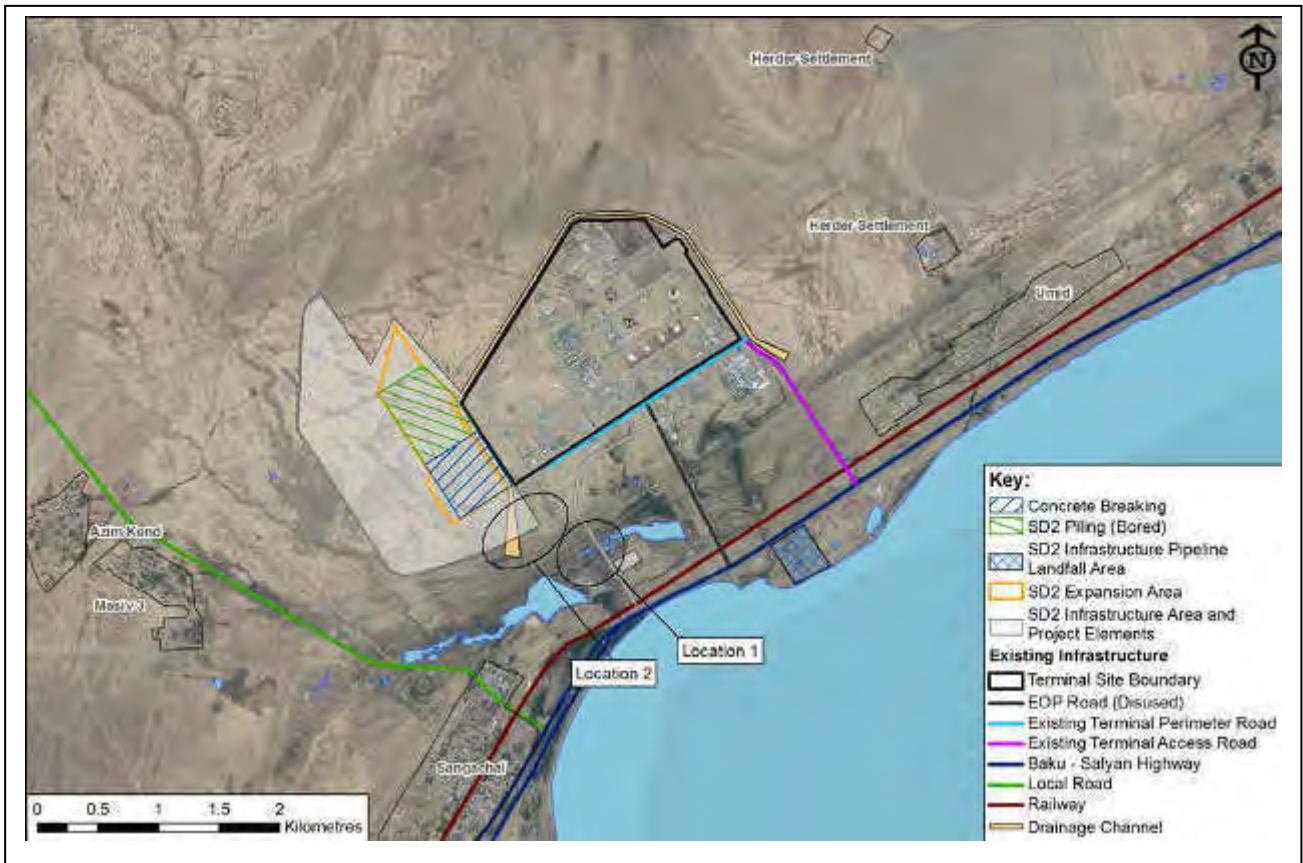

### 2.2.4 Concrete Breaking

Two noise levels have been assumed for the concrete breaking activities:

- 96 dB(A) for an excavator mounted breaker (based on actual measurements) at 10m from the activity; and
- 82 dB(A) for an associated concrete crusher (based on information contained within BS228) at 10m from the activity.

The location of the concrete breaking is assumed to be in the centre of the SD2 Expansion Area (Figure 3).

## 2.3 Receptors

The type and location of noise sensitive receptors included in the construction noise model are described in Table 3 and illustrated in Figure 4. Full details of the locations of receptors are provided in Annex A.

**Table 3: Noise Sensitive Receptors**

ID	Receptor & Assessment Position	Description and Location	Receptors
R1	<b>Azim Kend/Masiv 3</b> 40° 11'24.83" N 49° 26'11.11" E	Two small settlements 2.3km from the north west corner of the Terminal perimeter.	The closest residential receptors are single storey dwellings with a clear line of sight to the construction areas.
R2	<b>Sangachal</b> 40° 10'40.98" N 49° 27'52.68" E	Nearest main town 1.5km from the south west corner of the Terminal perimeter.	The closest residential receptors are multi-storeyed tower blocks with a clear line of sight to the construction areas.
R3	<b>Umid (west)</b> 40° 11'51.60" N 49° 30'03.96" E	Settlement located approximately 1km from the south east perimeter of the Terminal.	The closest receptors are single storey dwellings with a clear line of sight to the construction areas.
R4	<b>Umid (east)</b> 40.199815 N 49.511215 E	Settlement, on main entry road to camp, over 1km from Terminal boundary, and approximately 300m from the Baku-Salyan Highway (M3).	The closest residential receptors are single storey dwellings with a clear line of sight to both the construction areas and the Baku–Salyan Highway (M3).
R8	<b>Azim Kend</b> 40° 11'29.06" N 49° 25'57.02" E	Small settlement located north of Masiv 3. The measurement location was on a mound, with clear line of sight to the Terminal.	The closest residential receptors are single storey dwellings with a partial line of sight to the terminal. There are some two-storey buildings 100m further west.
R12	<b>Herder Settlement</b> 40° 12'28.03" N 49° 30'34.07" E	Measurement location on track just east of residences.	Single storey residences with clear line of sight to east boundary of terminal.

Figure 4: Noise Sensitive Receptors



### 3. BASELINE NOISE LEVELS

Previous baseline noise surveys have been completed at noise sensitive receptors within the vicinity of the Terminal. The most recent baseline noise measurements were taken during May 2010 and March 2011.

The results of the May 2010 and March 2011 baseline surveys are presented in Table 4 and 5, respectively.

**Table 4: Baseline Daytime Noise Survey Results for May 2010**

Location	Daytime LAeq	Daytime LA90	Daytime LA10	Main Noise Sources
Azim Kend/Masiv 3 R1	44 – 56	35 – 39	47 – 59	Road traffic noise from Baku-Salyan Highway, occasional car passing on road, distant aircraft and helicopter, birdsong.
Sangachal R2	50 – 62	48 – 52	51 – 67	Road traffic noise from Baku-Salyan Highway, vehicle horns, trains, distant aircraft and helicopter, birdsong.
Umid (west) R3	48 – 67	37 – 46	53 – 70	Road traffic noise from Baku-Salyan Highway, occasional car passing on road, distant aircraft and helicopter, birdsong.
Umid (east) R4	55 – 64	48 – 54	56 – 67	Road traffic noise from Baku-Salyan Highway, occasional passing car on track, distant aircraft and helicopter, local construction work, birdsong.

**Table 5: Baseline Daytime Noise Survey Results for March 2011**

Location	Daytime LAeq	Daytime LA90	Daytime LA10	Main Noise Sources
Azim Kend/Masiv 3 R1	50 – 53	42 - 43	53 – 56	Stone works, distant helicopter, cows, cock crow, local cars, helicopter, distant geese.
Sangachal R2	49 – 58	46 - 49	50 – 63	Distant traffic, HGVs, train horn, cars (7) distant helicopter, distant train, power station slightly audible, birds, tracked excavator, goats.
Umid (west) R3	62 - 70	45 - 46	64 - 75	Long goods train (1.5 minutes), distant traffic, passenger train, cock crow.
Umid (east) R4	51 – 54	46 – 47	52 – 55	Highway traffic, local cars and HGVs, dog barking.
Herder Settlement R12	45 – 47	39 – 40	48 – 50	Wind noise.

The March 2011 survey was completed just before an annual holiday period in Azerbaijan and therefore the road traffic noise levels recorded were lower when compared to the May 2010 survey.

The Baku-Salyan Highway is a dominant source of noise which results in noise levels of over 60 dB(A) at some receptor locations. Although no specific traffic data is available for the existing Baku-Salyan Highway, traffic levels have been estimated to be between 10,000 and 20,000 vehicles per day.



Noise from the use of local roads affected the noise levels recorded at Sangachal settlement (R2) only. Noise generated by the Terminal was not detected at any of the sensitive receptors during both the 2010 and 2011 daytime surveys.

## 4. ASSESSMENT SCENARIOS

### 4.1 Construction Plant Scenarios

Following a review of the project areas, activities and the location of the sensitive receptors, it was determined that the most intense and potential noisiest activities for the sensitive receptors would likely be those occurring within the SD2 Infrastructure Area.

The following scenarios were modelled to estimate the worst case and realistic<sup>2</sup> noise levels at receptors associated with the SD2 Infrastructure Project construction noise from this area:

1. **Worst case (no berm)** – 100% of plant at the boundary of the works (i.e. closest to the receptor being assessed), operating for 10 hours per day (85% of the working day) without the flood protection berm in place;
2. **Worst case (with berm)** – 100% of plant at boundary of the works (i.e. closest to the receptor being assessed), operating for 10 hours per day (85% of the working day) with the flood protection berm in place;
3. **Realistic scenario (no berm)** – 50% of plant at the boundary of the works (i.e. closest to the receptor being assessed), operating for 6 hours per day (50% of the working day) without the flood protection berm in place; and
4. **Realistic scenario (with berm)** – 50% of plant at the boundary of the works (i.e. closest to the receptor being assessed), operating for 6 hours per day (50% of the working day) with the flood protection berm in place.

Scenarios 2 and 4 take into account the attenuation provided by the flood protection berm. It is assumed that the berm will be in place from March 2012. The location and characteristics of the berm have been determined from Chapter 5 (Section 5.5.3) of the SD2 Infrastructure ESIA (Ref. 2). For the Umid (west and east) (R3 and R4) and the Herder Settlement (R12) receptor locations Scenarios 2 and 4 have not been modelled as the berm will provide no attenuation in relation to these locations.

### 4.2 Concrete Batching Plant

For the purpose of the assessment it has been assumed that the concrete batching plant is located at the south west boundary of the SD2 Infrastructure area. A worst case scenario has been assessed assuming the flood protection berm is not in place.

---

<sup>2</sup> Estimated based on types of plant and activities proposed for each construction phase and taking into account typical operating periods from similar projects.

### 4.3 Piling Scenarios

Noise associated with piling trials was assessed based on the following 4 scenarios:

- Tubular piling at a location 100m from the north west corner of the SD2 Expansion Area;
- Pre cast concrete piling at a location 100m from the north west corner of the SD2 Expansion Area;
- Tubular piling at a location 100m from the south west corner of the SD2 Expansion Area; and
- Pre cast concrete piling at a location 100m from the south west corner of the SD2 Expansion Area.

### 4.4 Concrete Breaking Scenarios

Concrete breaking has been modelled with and without a local acoustic screen.

### 4.5 Cumulative Scenarios

An assessment of the cumulative impacts has included the following activities taking place at the same time:

- Construction activities – realistic case – no flood protection berm in place;
- Pipeline crossing piling;
- Concrete breaking in SD2 Expansion Area; and
- Piling within the SD2 Expansion Area.

The assessment considers the most active period of construction between April and June 2012.

## 5. SCREENING ASSESSMENT RESULTS

### 5.1 Construction Plant (on-site)

The assessment of construction noise (on-site) has been undertaken for the 4 scenarios listed in Section 4.1 above. The results are presented below. The detailed calculation results are presented in Annex B.



### Receptor R1 – Azim Kend/Masiv 3

The predicted construction noise levels for each assessment scenario at Azim Kend/Masiv 3 are presented in Figure 5.

Figure 5: Predicted Construction Noise Levels at Receptor R1

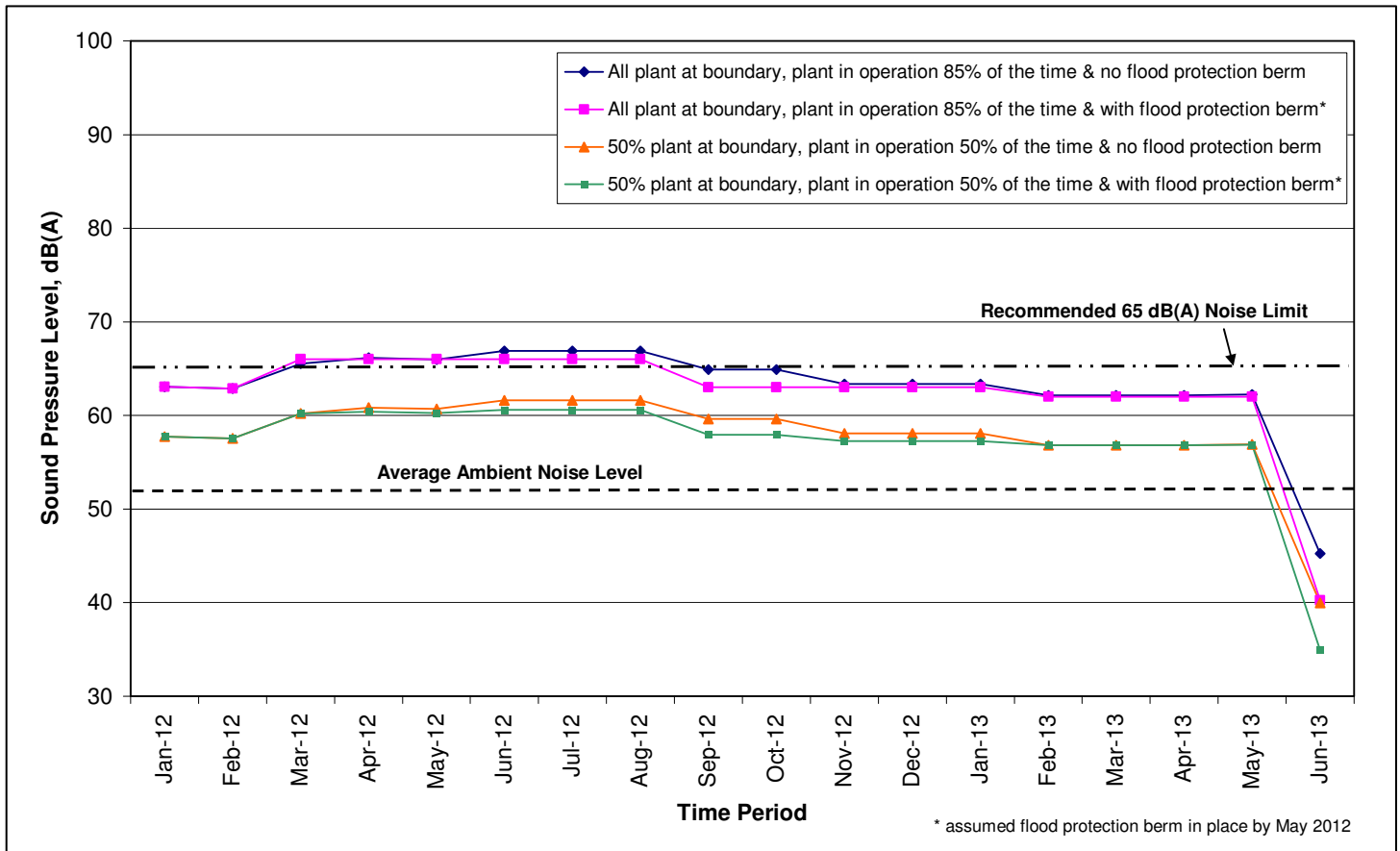

The results show that the highest noise levels are predicted to fall within the period March to September 2012, where construction activity will be at its most active. Under the worst case scenario, both with and without the flood protection berm (Scenarios 1 & 2), the construction noise limit of 65 dB(A) is exceeded during this period. After September 2012 with the flood protection berm in place (which lowers noise levels by approximately 1-2 dB at Azim Kend/Masiv 3 (R1)), even under worst case assumptions, construction noise levels at Azim Kend/Masiv 3 (R1) are expected to meet or be lower than the 65 dB(A) limit.

For the realistic case modelled (Scenarios 3 & 4), construction noise levels at R1 are predicted to be lower than the noise limit throughout the construction programme both with and without the flood protection berm.

### Receptor R2 – Sangachal

The predicted construction noise levels at Sangachal are presented in Figure 6.

**Figure 6: Predicted Construction Noise Levels at Receptor R2**

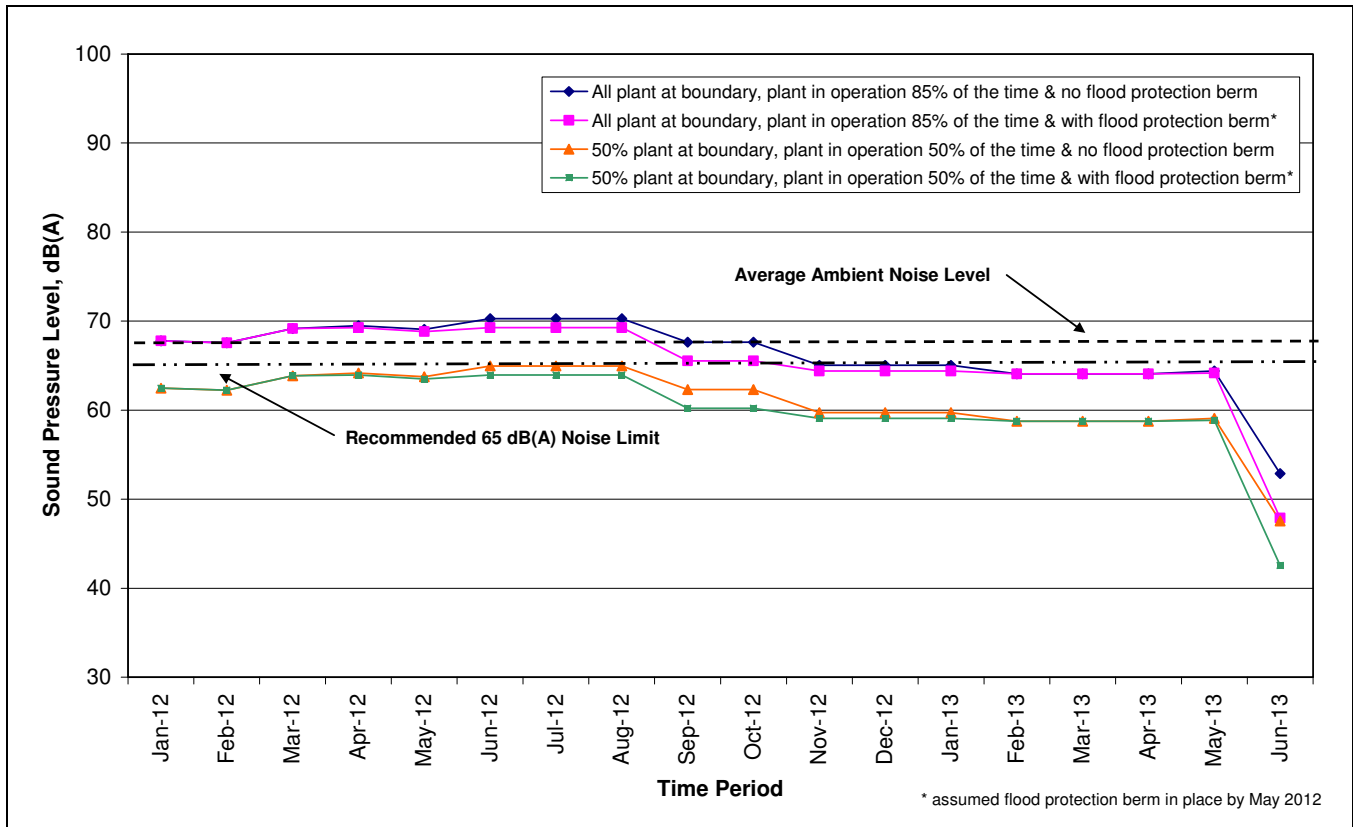

At Sangachal (R2), under the worst case scenario, both with and without the flood protection berm (Scenarios 1 & 2), the construction noise limit of 65 dB(A) is predicted to be exceeded between January 2012 - August 2012. After September 2012 with the flood protection berm in place, even under worst case assumptions, construction noise levels at R2 are expected to meet or be lower than the 65 dB(A) limit.

For the realistic cases modelled (Scenarios 3 & 4) construction noise levels at Sangachal (R2) are predicted to meet or be lower than the noise limit throughout the construction programme both with and without the flood protection berm.

**Receptor R3 – Umid (west)**

The predicted construction noise levels at Umid (west) are presented in Figure 7.

**Figure 7: Predicted Construction Noise Levels at Receptor R3**

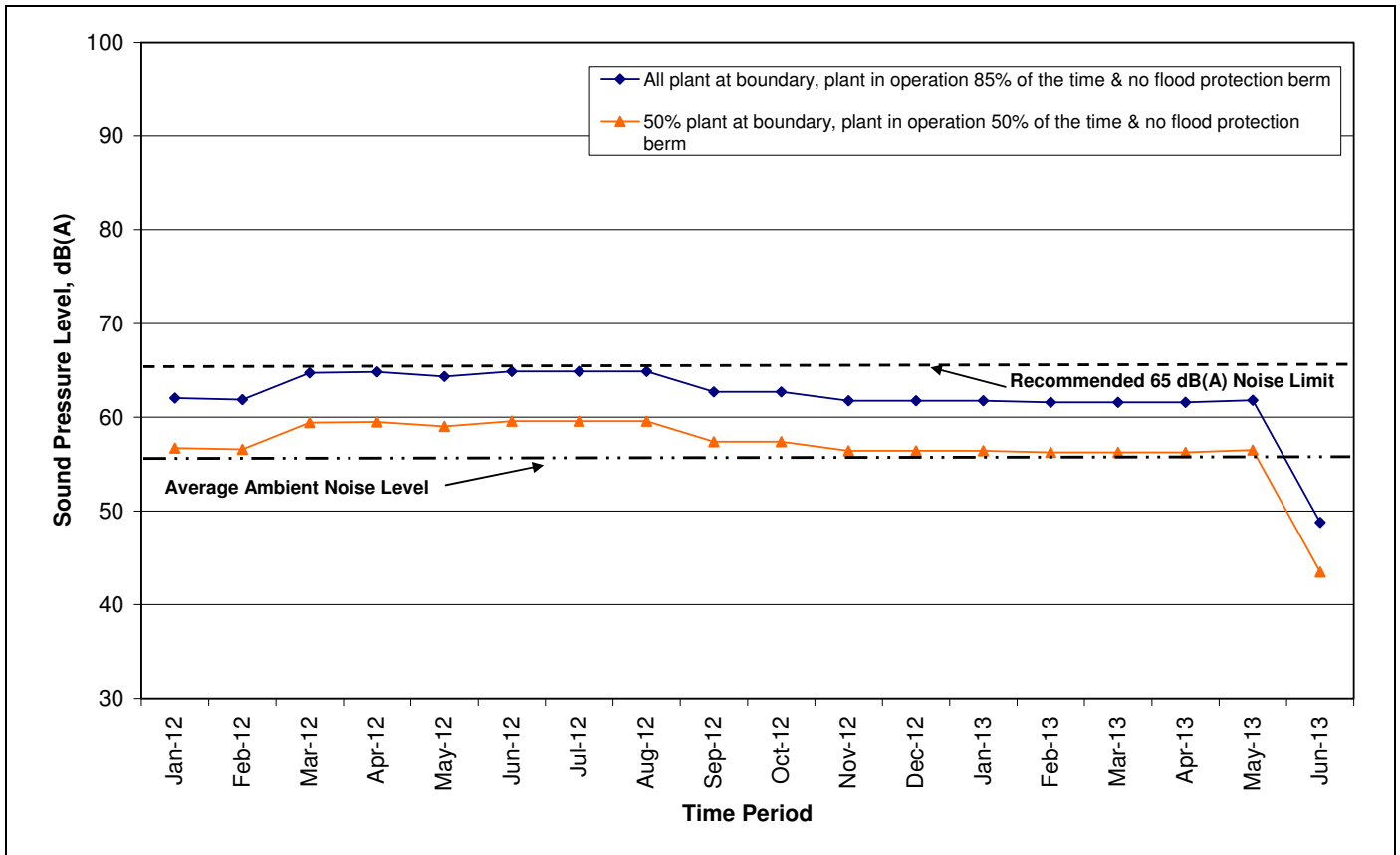

The construction noise levels at Umid (west) (R3) indicate that the predicted noise levels from construction will be no more than 65 dB(A) for both the worst case and realistic scenarios.

Given the location of the receptor (to the south east of the Terminal) the flood protection berm (which is located to the west of SD2 Infrastructure Area) was not included in the assessment at Umid (west).

**Receptor R4 – Umid (east)**

The predicted construction noise levels at Umid (east) are presented in Figure 8.

**Figure 8: Predicted Construction Noise Levels at Receptor R4**

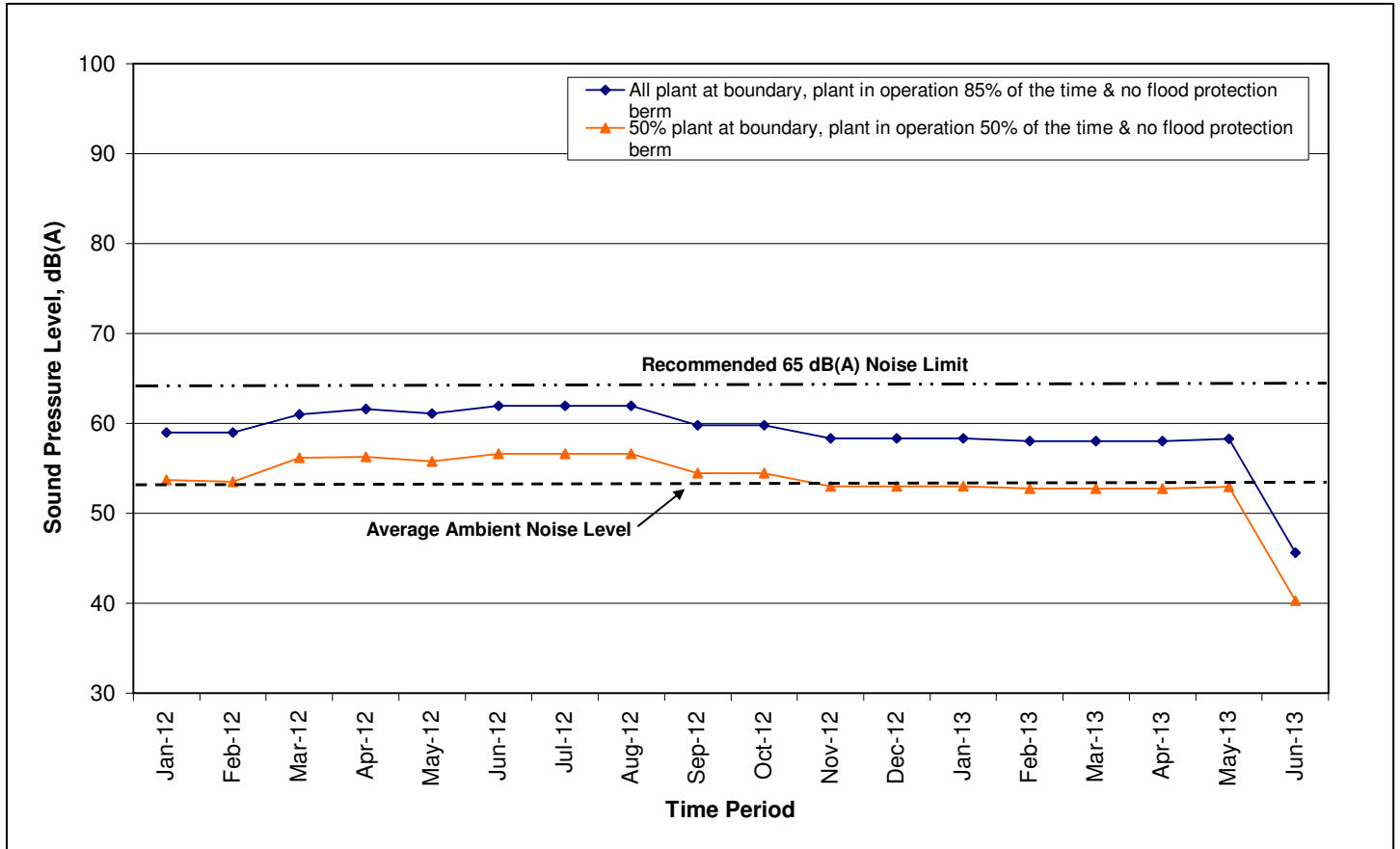

The calculated construction noise levels at Umid East (R4) indicate that the predicted noise levels from construction will be less than 65 dB(A) over the whole construction period for both worst case and realistic scenarios.

As for Umid (west) R3, given the location of the receptor, the flood protection berm was not included in the assessment at Umid (east).

**Receptor R8 – Azim Kend (North of Masiv 3)**

The predicted construction noise levels at this location are presented in Figure 9.

**Figure 9: Predicted Construction Noise Levels at Receptor R8**

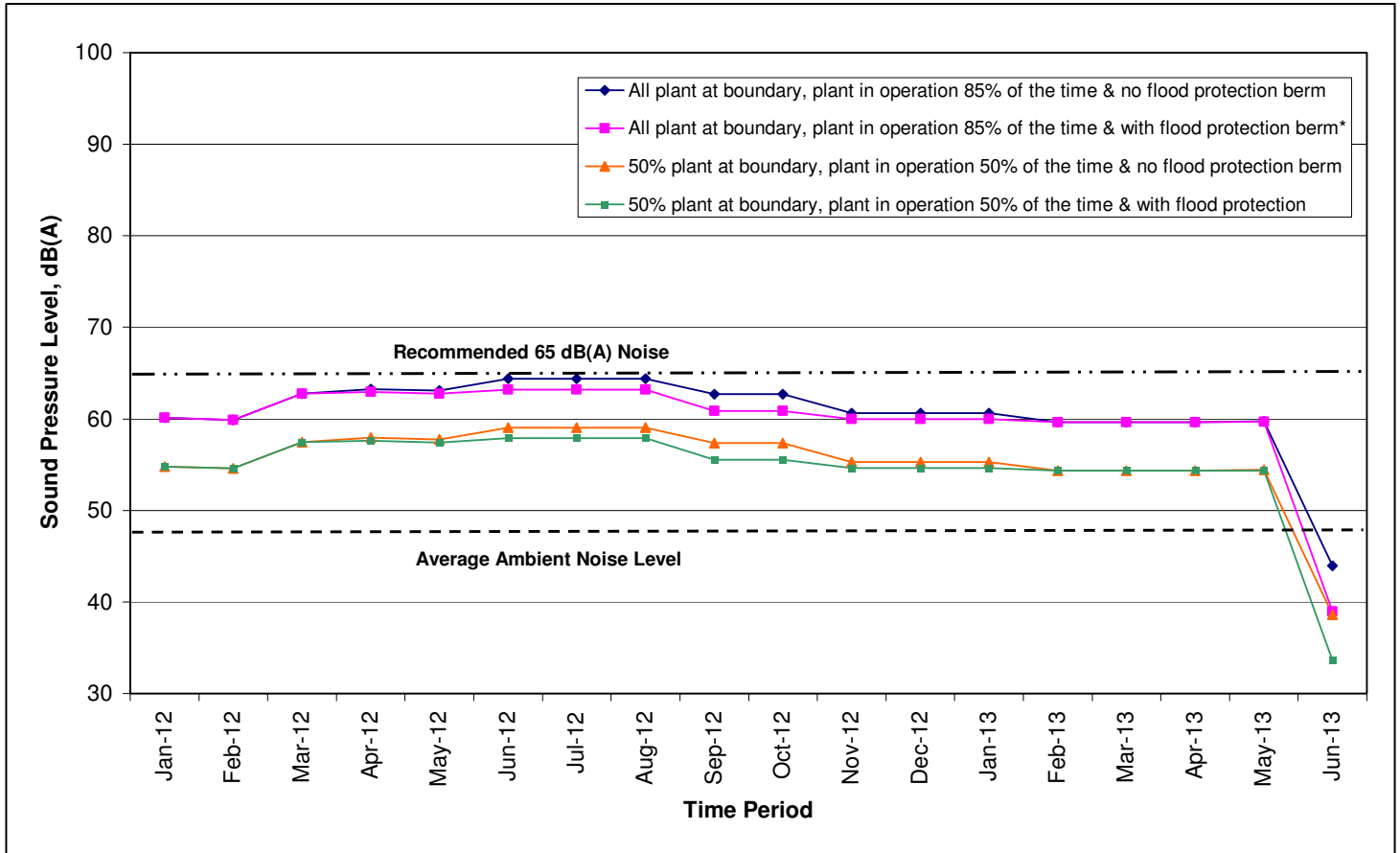

The calculated construction noise levels at Azim Kend (R8) indicate that the predicted noise levels from construction will be less than 65 dB(A) over the whole construction period for both worst case and realistic scenarios both with and without the flood protection berm.

### Receptor R12 – Herder Settlement

The predicted construction noise levels at the Herder Settlement (R12) to the east of the Sangachal Terminal are presented in Figure 10.

Figure 10: Predicted Construction Noise Levels at Receptor R12

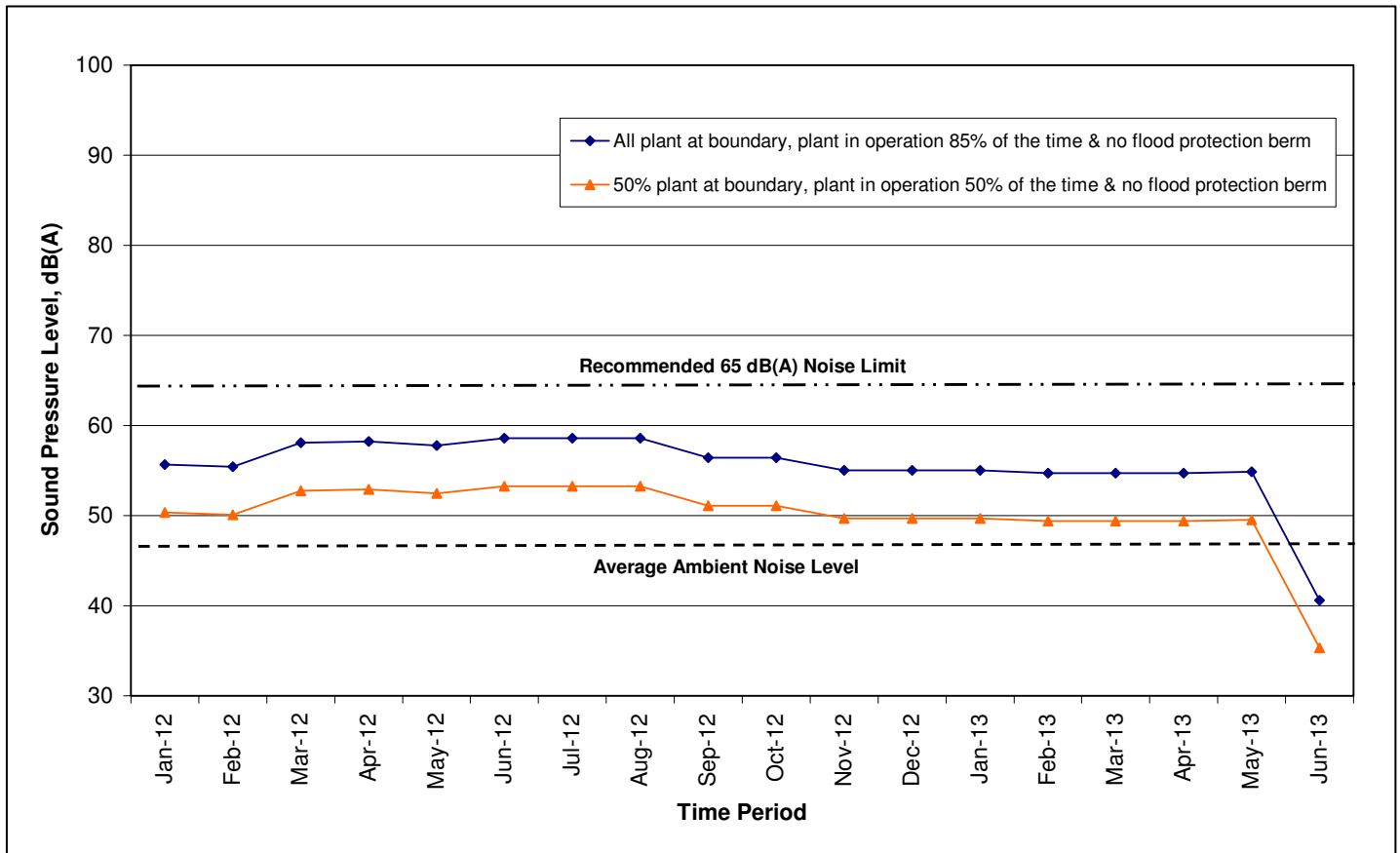

At the Herder Settlement location to the east of the Terminal (R12), construction noise levels are predicted to be less than 65 dB(A) over the whole construction period under both the worst case and realistic scenarios.

## 5.2 Concrete Batching Plant

The predicted noise levels associated with the operation of the concrete batching plant are presented in Table 5.

**Table 5: Predicted Noise Levels from Concrete Batching Plant**

Receptor	Receptor ID	Distance From Batching Plant (km)	Average ambient noise level, dB LAeq	Batching Plant Predicted Noise Level, dB LAeq
Azim Kend/Masiv 3	R1	2.2	52	39
Sangachal	R2	1	67	46
Umid (west)	R3	3.7	56	35
Umid (east)	R4	4.4	53	33
Azim Kend	R8	2.7	48	37
Herder Settlement	R12	4.7	47	33

The results of the construction noise model for the concrete batching plant indicate that the noise generated will be both below the 65 dB(A) limit value and below the average ambient noise levels measured at all receptors.

## 5.3 Piling

The results of the piling noise assessment are presented Table 6.

**Table 6: Noise Levels at Sensitive Receptors Associated with Piling Activities**

Scenario	Type of Piling	Location	Predicted Noise Level (dB(A))			Limit Value (dB(A))
			Azim Kend (R1)	Sangachal (R2)	Umid (west) (R3)	
<b><i>Bored Piling Associated with Pipeline Crossings</i></b>						
1	Rotary bored	Location 1	54	60	52	65
2		Location 2	52	58	54	
<b><i>Trial Piling</i></b>						
1	Tubular	100m from north west corner of SD2 Expansion Area	45	45	39	65
2	Pre cast concrete		46	46	40	
3	Tubular		44	49	40	
4	Pre cast concrete		45	50	41	

The modelling results indicate that no exceedances of the construction noise limit (65dB(A)) are predicted at any of the modelled receptors.

## 5.4 Concrete Breaking

The results of the concrete breaking are presented in Table 7.



**Table 7: Noise Levels at Sensitive Receptors Associated with Concrete Breaking**

Concrete Breaking		Location	Duration	Predicted Noise Level, dB(A)		
Scenario	Type			Azim Kend (R1)	Sangachal (R2)	Umid (west) (R3)
1	Breaking/Crushing	Centre of SD2 Expansion Area	100%	51	55	49
2	Breaking/Crushing with Screen	Centre of SD2 Expansion Area	100%	46	50	44

The modelling results indicate that no exceedances of the construction noise limit (65dB(A)) are predicted at any of the modelled receptors due to concrete breaking activities without a screen. The use of the screen further reduced the noise levels.

## 5.5 Cumulative Assessment

A cumulative assessment has been undertaken which considers all the construction activities discussed in this report operating concurrently. The assessment covers the most active period of construction (April–June 2012), and therefore is considered a worst case scenario. Table 8 presents the results of the cumulative assessment.

**Table 8: Cumulative Assessment of Noise Levels at Sensitive Receptors**

Activity	Predicted Noise Level, dB(A)		
	Azim Kend (R1)	Sangachal (R2)	Umid (west) (R3)
Construction – realistic – no berm	62	65	60
Pipeline crossing piling	54	60	52
Concrete breaking within the SD2 Expansion Area	51	55	49
Piling within the SD2 Expansion Area	54	60	52
<b>TOTAL NOISE dB(A)</b>	<b>63</b>	<b>67</b>	<b>61</b>

Noise levels are predicted to exceed 65 dB(A) at one modelled receptor, Sangachal, if all construction activities were to occur simultaneously. The predicted noise levels at Azim Kend and Umid West are predicted to be less than 65 dB(A).

## 6. CONCLUSIONS AND RECOMMENDATIONS

Tables 9 and 10 present a summary of the results of the construction plant noise modelling undertaken for the worst case and realistic scenarios across the construction period.

**Table 9: Worst Case Scenario Predicted Noise Levels (Construction Plant Only)**

Receptor	Receptor ID	Sound Pressure Levels, dB LAeq						Average Ambient Noise Level dB LAeq
		Jan – Mar 12	Apr – Jun 12	July – Sept 12	Oct – Dec 12	Jan – Mar 13	Apr – Jun 13	
Azim Kend/ Masiv 3	R1 (no berm)	63 - 66	66 - 67	65 - 67	63 - 65	62 - 63	45 - 62	52
	R1 (with berm)	-	66	66-63	63	62 - 63	40 - 62	
Sangachal	R2 (no berm)	68 - 69	69 - 70	68 - 70	65 - 68	64 - 65	53 - 64	67
	R2 (with berm)	-	69	66 - 69	64 - 66	64	48-64	
Umid (west)	R3	62 - 65	64 - 65	63 - 65	62 - 63	62	49 - 62	56
Umid (east)	R4	59 - 61	61 - 62	60 - 62	58 - 60	58	46 - 58	53
Azim Kend	R8 (no berm)	60 - 63	63 - 64	63 - 64	61 - 63	60 - 61	44 - 60	48
	R8 (with berm)	-	63	61-63	60-61	60	39 - 60	
Herder Settlement	R12	55 - 58	58 - 59	56 - 59	55 - 56	55	41 - 55	47

Note:  
Shading indicates results above the construction noise limit value of 65 dB(A)

**Table 10: Realistic Scenario Predicted Noise Levels (Construction Plant Only)**

Receptor	Receptor ID	Sound Pressure Levels, dB LAeq						Average Ambient Noise Level dB LAeq
		Jan – Mar 12	Apr – Jun 12	July – Sept 12	Oct – Dec 12	Jan – Mar 13	Apr – Jun 13	
Azim Kend/ Masiv 3	R1 (no berm)	58 - 60	61 - 62	60 - 62	58 - 60	57 - 58	40 - 57	52
	R1 (with berm)	-	60 - 61	58 - 61	57 - 58	57	35 - 57	
Sangachal	R2 (no berm)	62 - 64	64 - 65	62 - 65	60 - 62	59 - 60	48 - 59	67
	R2 (with berm)	-	64	60 - 64	59 - 60	59	43 - 59	
Umid (west)	R3	57 - 59	59 - 60	57 - 60	56 - 57	56	43 - 56	56
Umid (east)	R4	54 - 56	56 - 57	54 - 57	53-54	53	40 - 53	53
Azim Kend	R8 (no berm)	55 - 57	57 - 58	56 - 58	55 - 57	54 - 55	39 - 54	48
	R8 (with berm)	-	57- 58	56 - 58	55 - 56	54 - 55	34 - 54	
Herder Settlement	R12	50 - 53	52 - 53	51 - 53	50 - 51	49 - 50	35 - 50	47

Notes:  
Shading indicates results above the construction noise limit value of 65 dB(A).  
Bold indicates where results are above the construction noise limit value of 65 dB(A) but below or equivalent to existing average ambient noise level.

Table 9 shows that:

- **Under worst case assumptions** - 100% of plant at the boundary of the works (i.e. closest to the receptor being assessed), operating for 10 hours per day (85% of the working day):
  - Noise levels are predicted to range between 39 dB(A) (at R8 – Azim Kend - during June 2013) and 70 dB(A) (at R2 – Sangachal – July 2012);
  - No exceedances of the noise limit are predicted at receptors R3 (Umid West), R4 (Umid East), R8 (Azim Kend/Masiv 3) and R12 (Herder Settlement);
  - Exceedances are predicted at R1 (Azim Kend) and R2 (Sangachal) up to September and December 2012 respectively; and
  - The results show that while, the flood protection berm provides some noise attenuation, the number of exceedances is unchanged when it is included within the noise model.

Table 10 shows that:

- **Under realistic assumptions** - 50% of plant at the boundary of the works (i.e. closest to the receptor being assessed), operating for 6 hours per day (50% of the working day):
  - Noise levels are predicted to range between 34 dB(A) (at R8 – Azim Kend - during June 2013) and 65 dB(A) (at R2 – Sangachal – July 2012); and
  - No exceedances of the noise limit are predicted at receptors R1 (Azim Kend), R3 (Umid West), R4 (Umid East), R8 (Azim Kend/Masiv 3) and R12 (Herder Settlement).

Noise levels associated with the operation of the concrete batching plant at receptors are predicted to vary between 33-46 dB(A). This is both below the 65 dB(A) limit value and below the average ambient noise levels measured at all receptors.

Noise levels associated with piling activities indicate that no exceedances of the construction noise limit (65dB(A)) are predicted at any of the modelled receptors.

- For rotary bored piling associated with crossing works, noise levels are predicted to range between 52 and 60 dB(A), depending upon the location of piling activities;
- For tubular piling associated with trial piling, noise levels are predicted to range between 39 and 45 dB(A) if piling is located 100m from the north-west

corner of the SD2 Expansion Area, and between 40 and 49 dB(A) if piling is located 100m from the south-west corner of the SD2 Expansion Area; and

- For pre-cast concrete piling associated with trial piling, noise levels are predicted to range between 40 and 46 dB(A), if piling is located 100m from the north-west corner of the SD2 Expansion Area and between 41 and 50 dB(A) if piling is located 100m from the south-west corner of the SD2 Expansion Area.

Noise emissions generated by concrete breaking activities are predicted to range between 49 and 55 dB(A), and therefore, will be within the construction noise limit of 65 dB(A) for the modelled receptors.

The cumulative impact of all construction activities if they were to occur during the most active period of construction (April-June 2012) would be an exceedance of the guideline 65 dB(A) limit at Sangachal.

In summary it is considered, based on the realistic construction plant noise scenarios assessed, that **no significant noise impacts are expected during the construction programme**. In general, however, noise levels are predicted to be close to the noise limit, particular during March – August 2012, and under particularly active periods when plant may be operating for longer hours close to the site boundary, the limit may be exceeded.

### Recommendations

It is recommended therefore that the following measures should be adopted:

- Construction plant and vehicles shall be modern and well maintained in accordance with written procedures based on the manufacturer's guidelines, applicable industry code, or engineering standard to ensure efficient and reliable operation;
- Noisy plant equipment should be situated as far as possible from noise-sensitive buildings. Where practicable, barriers (e.g. site huts, acoustic partitions etc.) should be used to provide shielding in order to reduce noise levels at sensitive receptors;
- Vehicles and mechanical plant used for the purpose of the works should be fitted with effective exhaust silencers and maintained in good and efficient working order and operated in such a manner as to minimise noise emissions. The contractor must ensure that all plant complies with the relevant statutory requirements;
- Compressors should be fitted with properly lined and sealed acoustic covers that should be kept closed whenever in use. Pneumatic percussive tools should be fitted with mufflers or silencers of the type recommended by the manufacturers;
- Noise emitting machinery that is required to run continuously should be housed, if necessary, in a suitable acoustic enclosure;
- All construction plant and vehicles shall be switched off whilst not in use and not left to idle;

- Where practicable, rotary drills and bursters actuated by hydraulic, chemical or electrical power should be used for excavating hard or extrusive material;
- Care should be taken when loading or unloading vehicles, dismantling scaffolding or moving materials etc. to reduce impact noise;
- Where practicable, mains electricity shall be used instead of mobile generators as a power source; and
- Where possible communities shall be warned in advance of any particularly noise activities to be undertaken; when unavoidable, noisy operations shall be undertaken during normal daylight working hours.

## **7. REFERENCES**

- Ref. 1 Document BP-SFZZZZ-EV-REP-0005-A1, Shah Deniz Stage 2 Project, Sangachal Terminal Baseline Noise Survey, 30<sup>th</sup> June 2010.
- Ref. 2 Document BP-SFZZZZ-EV-REP-0023, Shah Deniz 2 Infrastructure Project, Environmental and Socio Economic Impact Assessment, Chapter 5 'Project Description', May 2011.
- Ref. 3 British Standards Institute (BSi), (2009): 'BS5228 - Noise and Vibration Control on Construction and Open Sites', BSi, London.
- Ref. 4 UK Institute of Environment Management and Assessment's (IEMA). 'Guidance Notes No. 1 Guidelines for the Environmental Assessment of Road Traffic'.
- Ref. 5 UK Highways Agency, (August 1994); 'Design Manual for Road and Bridges Volume 11 Section 3 Part 7-Traffic Noise and Vibration'.

# **Annex A: Receptor Distances from Construction Areas**



Receptor	Description	Phase 1	Phase 2	Phase 3	Phase 4	Phase 5	Phase 6	Phase 7
		m	m	m	m	m	m	m
R1	Azim Kend/Masiv 3	2600	2400	1400	1500	2000	1300	2400
R2	Sangachal	1400	1000	850	1200	1200	1200	1000
R3	Umid West	3200	1600	1700	1600	3200	4000	1600
R4	Umid East	3900	2300	2400	2400	3700	4700	2300
R8	Azim Kend North of Masiv 3	3200	3000	2000	2000	2300	2000	2800
R12	Herders Settlement	3600	2500	2500	2500	3900	4600	2900

## **Annex B: Construction Noise Calculations (worst-case scenario – no flood protection berm)**

Plant	Noise dB(A) at 10m	Stage													
		Phase 1		Phase 2		Phase 3		Phase 4		Phase 5		Phase 6		Phase 7	
		Qty	dB(A)	Qty	dB(A)	Qty	dB(A)	Qty	dB(A)	Qty	dB(A)	Qty	dB(A)	Qty	dB(A)
Bulldozer - D6/D8/D9/D10	79	1	79	1	79	6	87	6	87	6	87	0	0	0	0
Wheeled Loader - 25t	79	2	82	2	82	5	86	5	86	5	86	0	0	0	0
Tracked Excavator - 27t	75	1	75	1	75	5	82	5	82	5	82	0	0	0	0
Dump Truck - 25t	85	2	88	2	88	38	101	38	101	38	101	0	0	1	85
Motor Grader - 25t	86	1	86	1	86	2	89	3	91	5	93	0	0	0	0
Sheep Foot Roller/Vibro Roller - 10t	80	1	80	1	80	2	83	1	80	3	85	3	85	0	0
Road Roller - 13t	80	0	0	0	0	0	0	2	83	1	80	0	0	0	0
Asphalt Paver (and tipper lorry)	77	0	0	0	0	0	0	3	82	0	0	0	0	0	0
Road Lorry - 25t	80	8	89	4	86	28	94	28	94	28	94	11	90	0	0
Diesel Generator (50/100 kVA)	65	1	65	2	68	7	73	7	73	7	73	9	75	1	65
Mechanical Water Bowser	83	1	83	7	91	7	91	7	91	8	92	8	92	0	0
Tracked Mobile Crane - 115t	75	0	0	2	78	2	78	2	78	1	75	4	81	0	0
Mobile Telescopic Crane - 25t	82	0	0	1	82	2	85	3	87	2	85	1	82	0	0
Earthworks Compactor - 10t	73	0	0	0	0	7	81	7	81	7	81	0	0	0	0
Concrete Mixer - 200 litres	80	0	0	1	80	2	83	3	85	2	83	1	80	0	0
Fork Lift Trucks - 5t	77	1	77	3	82	3	82	3	82	3	82	1	77	0	0
Water Pump 20 kW	79	1	79	2	82	6	87	6	87	2	82	1	79	0	0
Concrete Pumps	65	0	0	0	0	2	68	3	70	1	65	2	68	0	0
Air Compressor - 8/20 m3/min	65	1	65	2	68	2	68	2	68	2	68	1	65	1	65
Backhoe Loader - 10t	67	0	0	4	73	3	72	0	0	2	70	2	70	0	0
Welding Set	73	1	73	1	73	2	76	2	76	2	76	2	76	1	73
Compactor Plate	82	0	0	1	82	2	85	2	85	2	85	6	90	0	0
JCB Tractor	67	1	67	1	67	2	70	2	70	2	70	4	73	1	67
Tilting Drum Mixer	61	0	0	1	61	1	61	1	61	1	61	4	67	1	61
Fuel Bowser	89	1	89	1	89	1	89	1	89	1	89	1	89	1	89
<b>Total Noise at 10m</b>		<b>95</b>		<b>97</b>		<b>103</b>		<b>103</b>		<b>103</b>		<b>97</b>		<b>91</b>	

			Stage							Total All Phases
			Phase 1 dB(A)	Phase 2 dB(A)	Phase 3 dB(A)	Phase 4 dB(A)	Phase 5 dB(A)	Phase 6 dB(A)	Phase 7 dB(A)	
Receptor	Azim Kend	R1	95	97	103	103	103	97	91	
Distance (m)			2600	2400	1400	1500	2000	1300	2400	
Screening			0	0	0	0	0	0	0	
Plant at Boundary			100%	100%	100%	100%	100%	100%	100%	
Façade			3	3	3	3	3	3	3	
On Time %			85%	85%	85%	85%	85%	85%	85%	
<b>Noise level dB(A)</b>			<b>49</b>	<b>52</b>	<b>63</b>	<b>62</b>	<b>60</b>	<b>57</b>	<b>45</b>	
<b>R1</b>										
	Jan-12		49	52	63	0	0	0	0	63
	Feb-12		0	52	63	0	0	0	0	63
	Mar-12		0	52	63	62	0	0	0	66
	Apr-12		0	52	63	62	0	57	0	66
	May-12		0	0	63	62	0	57	0	66
	Jun-12		0	0	63	62	60	57	0	67
	Jul-12		0	0	63	62	60	57	0	67
	Aug-12		0	0	63	62	60	57	0	67
	Sep-12		0	0	0	62	60	57	0	65
	Oct-12		0	0	0	62	60	57	0	65
	Nov-12		0	0	0	62	0	57	0	63
	Dec-12		0	0	0	62	0	57	0	63
	Jan-13		0	0	0	62	0	57	0	63
	Feb-13		0	0	0	62	0	0	0	62
	Mar-13		0	0	0	62	0	0	0	62
	Apr-13		0	0	0	62	0	0	0	62
	May-13		0	0	0	62	0	0	45	62
	Jun-13		0	0	0	0	0	0	45	45

			Stage							Total All Phases
			Phase 1 dB(A)	Phase 2 dB(A)	Phase 3 dB(A)	Phase 4 dB(A)	Phase 5 dB(A)	Phase 6 dB(A)	Phase 7 dB(A)	
Receptor	Sangachal	R2	95	97	103	103	103	97	91	
Distance (m)			1400	1000	850	1200	1200	1200	1000	
Screening			0	0	0	0	0	0	0	
Plant at Boundary			100%	100%	100%	100%	100%	100%	100%	
Façade			3	3	3	3	3	3	3	
On Time %			85%	85%	85%	85%	85%	85%	85%	
<b>Noise level dB(A)</b>			<b>55</b>	<b>59</b>	<b>67</b>	<b>64</b>	<b>64</b>	<b>58</b>	<b>53</b>	
<b>R2</b>										
	Jan-12		55	59	67	0	0	0	0	68
	Feb-12		0	59	67	0	0	0	0	68
	Mar-12		0	59	67	64	0	0	0	69
	Apr-12		0	59	67	64	0	58	0	69
	May-12		0	0	67	64	0	58	0	69
	Jun-12		0	0	67	64	64	58	0	70
	Jul-12		0	0	67	64	64	58	0	70
	Aug-12		0	0	67	64	64	58	0	70
	Sep-12		0	0	0	64	64	58	0	68
	Oct-12		0	0	0	64	64	58	0	68
	Nov-12		0	0	0	64	0	58	0	65
	Dec-12		0	0	0	64	0	58	0	65
	Jan-13		0	0	0	64	0	58	0	65
	Feb-13		0	0	0	64	0	0	0	64
	Mar-13		0	0	0	64	0	0	0	64
	Apr-13		0	0	0	64	0	0	0	64
	May-13		0	0	0	64	0	0	53	64
	Jun-13		0	0	0	0	0	0	53	53

			Stage							Total All Phases
			Phase 1 dB(A)	Phase 2 dB(A)	Phase 3 dB(A)	Phase 4 dB(A)	Phase 5 dB(A)	Phase 6 dB(A)	Phase 7 dB(A)	
Receptor	Umid West	R3	95	97	103	103	103	97	91	
Distance (m)			3200	1600	1700	1600	3200	4000	1600	
Screening			0	0	0	0	0	0	0	
Plant at Boundary			100%	100%	100%	100%	100%	100%	100%	
Façade			3	3	3	3	3	3	3	
On Time %			85%	85%	85%	85%	85%	85%	85%	
<b>Noise level dB(A)</b>			<b>47</b>	<b>55</b>	<b>61</b>	<b>62</b>	<b>56</b>	<b>48</b>	<b>49</b>	
R3	Jan-12		47	55	61	0	0	0	0	62
	Feb-12		0	55	61	0	0	0	0	62
	Mar-12		0	55	61	62	0	0	0	65
	Apr-12		0	55	61	62	0	48	0	65
	May-12		0	0	61	62	0	48	0	64
	Jun-12		0	0	61	62	56	48	0	65
	Jul-12		0	0	61	62	56	48	0	65
	Aug-12		0	0	61	62	56	48	0	65
	Sep-12		0	0	0	62	56	48	0	63
	Oct-12		0	0	0	62	56	48	0	63
	Nov-12		0	0	0	62	0	48	0	62
	Dec-12		0	0	0	62	0	48	0	62
	Jan-13		0	0	0	62	0	48	0	62
	Feb-13		0	0	0	62	0	0	0	62
	Mar-13		0	0	0	62	0	0	0	62
	Apr-13		0	0	0	62	0	0	0	62
	May-13		0	0	0	62	0	0	49	62
Jun-13		0	0	0	0	0	0	49	49	

			Stage							Total All Phases
			Phase 1 dB(A)	Phase 2 dB(A)	Phase 3 dB(A)	Phase 4 dB(A)	Phase 5 dB(A)	Phase 6 dB(A)	Phase 7 dB(A)	
Receptor	Umid East	R4	95	97	103	103	103	97	91	
Distance (m)			3900	2300	2400	2400	3700	4700	2300	
Screening			0	0	0	0	0	0	0	
Plant at Boundary			100%	100%	100%	100%	100%	100%	100%	
Façade			3	3	3	3	3	3	3	
On Time %			85%	85%	85%	85%	85%	85%	85%	
<b>Noise level dB(A)</b>			<b>46</b>	<b>52</b>	<b>58</b>	<b>58</b>	<b>54</b>	<b>46</b>	<b>46</b>	
R4	Jan-12		46	52	58	0	0	0	0	59
	Feb-12		0	52	58	0	0	0	0	59
	Mar-12		0	52	58	58	0	0	0	61
	Apr-12		0	52	58	58	0	46	0	62
	May-12		0	0	58	58	0	46	0	61
	Jun-12		0	0	58	58	54	46	0	62
	Jul-12		0	0	58	58	54	46	0	62
	Aug-12		0	0	58	58	54	46	0	62
	Sep-12		0	0	0	58	54	46	0	60
	Oct-12		0	0	0	58	54	46	0	60
	Nov-12		0	0	0	58	0	46	0	58
	Dec-12		0	0	0	58	0	46	0	58
	Jan-13		0	0	0	58	0	46	0	58
	Feb-13		0	0	0	58	0	0	0	58
	Mar-13		0	0	0	58	0	0	0	58
	Apr-13		0	0	0	58	0	0	0	58
	May-13		0	0	0	58	0	0	46	58
Jun-13		0	0	0	0	0	0	46	46	

			Stage							Total All Phases
			Phase 1 dB(A)	Phase 2 dB(A)	Phase 3 dB(A)	Phase 4 dB(A)	Phase 5 dB(A)	Phase 6 dB(A)	Phase 7 dB(A)	
Receptor	North of Azim Kend/Masiv	R8	95	97	103	103	103	97	91	
Distance (m)			3200	3000	2000	2000	2300	2000	2800	
Screening			0	0	0	0	0	0	0	
Plant at Boundary			100%	100%	100%	100%	100%	100%	100%	
Façade			3	3	3	3	3	3	3	
On Time %			85%	85%	85%	85%	85%	85%	85%	
<b>Noise level dB(A)</b>			<b>47</b>	<b>50</b>	<b>59</b>	<b>60</b>	<b>58</b>	<b>54</b>	<b>44</b>	
<b>R8</b>										<b>60</b>
	Jan-12		47	50	59	0	0	0	0	<b>60</b>
	Feb-12		0	50	59	0	0	0	0	<b>60</b>
	Mar-12		0	50	59	60	0	0	0	<b>63</b>
	Apr-12		0	50	59	60	0	54	0	<b>63</b>
	May-12		0	0	59	60	0	54	0	<b>63</b>
	Jun-12		0	0	59	60	58	54	0	<b>64</b>
	Jul-12		0	0	59	60	58	54	0	<b>64</b>
	Aug-12		0	0	59	60	58	54	0	<b>64</b>
	Sep-12		0	0	0	60	58	54	0	<b>63</b>
	Oct-12		0	0	0	60	58	54	0	<b>63</b>
	Nov-12		0	0	0	60	0	54	0	<b>61</b>
	Dec-12		0	0	0	60	0	54	0	<b>61</b>
	Jan-13		0	0	0	60	0	54	0	<b>61</b>
	Feb-13		0	0	0	60	0	0	0	<b>60</b>
	Mar-13		0	0	0	60	0	0	0	<b>60</b>
	Apr-13		0	0	0	60	0	0	0	<b>60</b>
	May-13		0	0	0	60	0	0	44	<b>60</b>
	Jun-13		0	0	0	0	0	0	44	<b>44</b>

			Stage							Total All Phases
			Phase 1 dB(A)	Phase 2 dB(A)	Phase 3 dB(A)	Phase 4 dB(A)	Phase 5 dB(A)	Phase 6 dB(A)	Phase 7 dB(A)	
Receptor	Herder Settlement	R12	95	97	103	103	103	97	91	
Distance (m)			3600	2500	2500	2500	3900	4600	2900	
Screening			0	0	0	0	0	0	0	
Plant at Boundary			100%	100%	100%	100%	100%	100%	100%	
Façade			0	0	0	0	0	0	0	
On Time %			85%	85%	85%	85%	85%	85%	85%	
<b>Noise level dB(A)</b>			<b>43</b>	<b>48</b>	<b>55</b>	<b>55</b>	<b>51</b>	<b>43</b>	<b>41</b>	
<b>R12</b>										<b>56</b>
	Jan-12		43	48	55	0	0	0	0	<b>56</b>
	Feb-12		0	48	55	0	0	0	0	<b>55</b>
	Mar-12		0	48	55	55	0	0	0	<b>58</b>
	Apr-12		0	48	55	55	0	43	0	<b>58</b>
	May-12		0	0	55	55	0	43	0	<b>58</b>
	Jun-12		0	0	55	55	51	43	0	<b>59</b>
	Jul-12		0	0	55	55	51	43	0	<b>59</b>
	Aug-12		0	0	55	55	51	43	0	<b>59</b>
	Sep-12		0	0	0	55	51	43	0	<b>56</b>
	Oct-12		0	0	0	55	51	43	0	<b>56</b>
	Nov-12		0	0	0	55	0	43	0	<b>55</b>
	Dec-12		0	0	0	55	0	43	0	<b>55</b>
	Jan-13		0	0	0	55	0	43	0	<b>55</b>
	Feb-13		0	0	0	55	0	0	0	<b>55</b>
	Mar-13		0	0	0	55	0	0	0	<b>55</b>
	Apr-13		0	0	0	55	0	0	0	<b>55</b>
	May-13		0	0	0	55	0	0	41	<b>55</b>
	Jun-13		0	0	0	0	0	0	41	<b>41</b>

## **Annex C: Construction Noise Calculations (realistic scenario – no flood protection berm)**



Plant	Noise dB(A) at 10m	Stage													
		Phase 1		Phase 2		Phase 3		Phase 4		Phase 5		Phase 6		Phase 7	
		Qty	dB(A)	Qty	dB(A)	Qty	dB(A)	Qty	dB(A)	Qty	dB(A)	Qty	dB(A)	Qty	dB(A)
Bulldozer - D6/D8/D9/D10	79	1	79	1	79	6	87	6	87	6	87	0	0	0	0
Wheeled Loader - 25t	79	2	82	2	82	5	86	5	86	5	86	0	0	0	0
Tracked Excavator - 27t	75	1	75	1	75	5	82	5	82	5	82	0	0	0	0
Dump Truck - 25t	85	2	88	2	88	38	101	38	101	38	101	0	0	1	85
Motor Grader - 25t	86	1	86	1	86	2	89	3	91	5	93	0	0	0	0
Sheep Foot Roller/Vibro Roller - 10t	80	1	80	1	80	2	83	1	80	3	85	3	85	0	0
Road Roller - 13t	80	0	0	0	0	0	0	2	83	1	80	0	0	0	0
Asphalt Paver (and tipper lorry)	77	0	0	0	0	0	0	3	82	0	0	0	0	0	0
Road Lorry - 25t	80	8	89	4	86	28	94	28	94	28	94	11	90	0	0
Diesel Generator (50/100 kVA)	65	1	65	2	68	7	73	7	73	7	73	9	75	1	65
Mechanical Water Bowser	83	1	83	7	91	7	91	7	91	8	92	8	92	0	0
Tracked Mobile Crane - 115t	75	0	0	2	78	2	78	2	78	1	75	4	81	0	0
Mobile Telescopic Crane - 25t	82	0	0	1	82	2	85	3	87	2	85	1	82	0	0
Earthworks Compactor - 10t	73	0	0	0	0	7	81	7	81	7	81	0	0	0	0
Concrete Mixer - 200 litres	80	0	0	1	80	2	83	3	85	2	83	1	80	0	0
Fork Lift Trucks - 5t	77	1	77	3	82	3	82	3	82	3	82	1	77	0	0
Water Pump 20 kW	79	1	79	2	82	6	87	6	87	2	82	1	79	0	0
Concrete Pumps	65	0	0	0	0	2	68	3	70	1	65	2	68	0	0
Air Compressor - 8/20 m3/min	65	1	65	2	68	2	68	2	68	2	68	1	65	1	65
Backhoe Loader - 10t	67	0	0	4	73	3	72	0	0	2	70	2	70	0	0
Welding Set	73	1	73	1	73	2	76	2	76	2	76	2	76	1	73
Compactor Plate	82	0	0	1	82	2	85	2	85	2	85	6	90	0	0
JCB Tractor	67	1	67	1	67	2	70	2	70	2	70	4	73	1	67
Tilting Drum Mixer	61	0	0	1	61	1	61	1	61	1	61	4	67	1	61
Fuel Bowser	89	1	89	1	89	1	89	1	89	1	89	1	89	1	89

			Stage							
			Phase 1 dB(A)	Phase 2 dB(A)	Phase 3 dB(A)	Phase 4 dB(A)	Phase 5 dB(A)	Phase 6 dB(A)	Phase 7 dB(A)	
Receptor	Azim Kend	R1	95	97	103	103	103	97	91	
Distance (m)			2600	2400	1400	1500	2000	1300	2400	
Screening			0	0	0	0	0	0	0	
Plant at Boundary			50%	50%	50%	50%	50%	50%	50%	
Façade			3	3	3	3	3	3	3	
On Time %			50%	50%	50%	50%	50%	50%	50%	
<b>Noise level dB(A)</b>			<b>44</b>	<b>46</b>	<b>57</b>	<b>57</b>	<b>54</b>	<b>52</b>	<b>40</b>	
<b>R1</b>										Total All Phases
	Jan-12		44	46	57	0	0	0	0	58
	Feb-12		0	46	57	0	0	0	0	58
	Mar-12		0	46	57	57	0	0	0	60
	Apr-12		0	46	57	57	0	52	0	61
	May-12		0	0	57	57	0	52	0	61
	Jun-12		0	0	57	57	54	52	0	62
	Jul-12		0	0	57	57	54	52	0	62
	Aug-12		0	0	57	57	54	52	0	62
	Sep-12		0	0	0	57	54	52	0	60
	Oct-12		0	0	0	57	54	52	0	60
	Nov-12		0	0	0	57	0	52	0	58
	Dec-12		0	0	0	57	0	52	0	58
	Jan-13		0	0	0	57	0	52	0	58
	Feb-13		0	0	0	57	0	0	0	57
	Mar-13		0	0	0	57	0	0	0	57
	Apr-13		0	0	0	57	0	0	0	57
	May-13		0	0	0	57	0	0	40	57
	Jun-13		0	0	0	0	0	0	40	40

			Stage							
			Phase 1 dB(A)	Phase 2 dB(A)	Phase 3 dB(A)	Phase 4 dB(A)	Phase 5 dB(A)	Phase 6 dB(A)	Phase 7 dB(A)	
Receptor	Sangachal	R2	95	97	103	103	103	97	91	
Distance (m)			1400	1000	850	1200	1200	1200	1000	
Screening			0	0	0	0	0	0	0	
Plant at Boundary			50%	50%	50%	50%	50%	50%	50%	
Façade			3	3	3	3	3	3	3	
On Time %			50%	50%	50%	50%	50%	50%	50%	
<b>Noise level dB(A)</b>			<b>49</b>	<b>54</b>	<b>62</b>	<b>59</b>	<b>59</b>	<b>53</b>	<b>48</b>	
<b>R2</b>										Total All Phases
	Jan-12		49	54	62	0	0	0	0	62
	Feb-12		0	54	62	0	0	0	0	62
	Mar-12		0	54	62	59	0	0	0	64
	Apr-12		0	54	62	59	0	53	0	64
	May-12		0	0	62	59	0	53	0	64
	Jun-12		0	0	62	59	59	53	0	65
	Jul-12		0	0	62	59	59	53	0	65
	Aug-12		0	0	62	59	59	53	0	65
	Sep-12		0	0	0	59	59	53	0	62
	Oct-12		0	0	0	59	59	53	0	62
	Nov-12		0	0	0	59	0	53	0	60
	Dec-12		0	0	0	59	0	53	0	60
	Jan-13		0	0	0	59	0	53	0	60
	Feb-13		0	0	0	59	0	0	0	59
	Mar-13		0	0	0	59	0	0	0	59
	Apr-13		0	0	0	59	0	0	0	59
	May-13		0	0	0	59	0	0	48	59
	Jun-13		0	0	0	0	0	0	48	48

			Stage							Total All Phases
			Phase 1	Phase 2	Phase 3	Phase 4	Phase 5	Phase 6	Phase 7	
			dB(A)	dB(A)	dB(A)	dB(A)	dB(A)	dB(A)	dB(A)	
Receptor	Umid West	R3	95	97	103	103	103	97	91	
Distance (m)			3200	1600	1700	1600	3200	4000	1600	
Screening			0	0	0	0	0	0	0	
Plant at Boundary			50%	50%	50%	50%	50%	50%	50%	
Façade			3	3	3	3	3	3	3	
On Time %			50%	50%	50%	50%	50%	50%	50%	
<b>Noise level dB(A)</b>			<b>42</b>	<b>50</b>	<b>56</b>	<b>56</b>	<b>50</b>	<b>42</b>	<b>43</b>	
<b>R3</b>										
	Jan-12		42	50	56	0	0	0	0	57
	Feb-12		0	50	56	0	0	0	0	57
	Mar-12		0	50	56	56	0	0	0	59
	Apr-12		0	50	56	56	0	42	0	60
	May-12		0	0	56	56	0	42	0	59
	Jun-12		0	0	56	56	50	42	0	60
	Jul-12		0	0	56	56	50	42	0	60
	Aug-12		0	0	56	56	50	42	0	60
	Sep-12		0	0	0	56	50	42	0	57
	Oct-12		0	0	0	56	50	42	0	57
	Nov-12		0	0	0	56	0	42	0	56
	Dec-12		0	0	0	56	0	42	0	56
	Jan-13		0	0	0	56	0	42	0	56
	Feb-13		0	0	0	56	0	0	0	56
	Mar-13		0	0	0	56	0	0	0	56
	Apr-13		0	0	0	56	0	0	0	56
	May-13		0	0	0	56	0	0	43	56
	Jun-13		0	0	0	0	0	0	43	43

			Stage							Total All Phases
			Phase 1	Phase 2	Phase 3	Phase 4	Phase 5	Phase 6	Phase 7	
			dB(A)	dB(A)	dB(A)	dB(A)	dB(A)	dB(A)	dB(A)	
Receptor	Umid East	R4	95	97	103	103	103	97	91	
Distance (m)			3900	2300	2400	2400	3700	4700	2300	
Screening			0	0	0	0	0	0	0	
Plant at Boundary			50%	50%	50%	50%	50%	50%	50%	
Façade			3	3	3	3	3	3	3	
On Time %			50%	50%	50%	50%	50%	50%	50%	
<b>Noise level dB(A)</b>			<b>40</b>	<b>47</b>	<b>53</b>	<b>53</b>	<b>49</b>	<b>41</b>	<b>40</b>	
<b>R4</b>										
	Jan-12		40	47	53	0	0	0	0	54
	Feb-12		0	47	53	0	0	0	0	54
	Mar-12		0	47	53	53	0	0	0	56
	Apr-12		0	47	53	53	0	41	0	56
	May-12		0	0	53	53	0	41	0	56
	Jun-12		0	0	53	53	49	41	0	57
	Jul-12		0	0	53	53	49	41	0	57
	Aug-12		0	0	53	53	49	41	0	57
	Sep-12		0	0	0	53	49	41	0	54
	Oct-12		0	0	0	53	49	41	0	54
	Nov-12		0	0	0	53	0	41	0	53
	Dec-12		0	0	0	53	0	41	0	53
	Jan-13		0	0	0	53	0	41	0	53
	Feb-13		0	0	0	53	0	0	0	53
	Mar-13		0	0	0	53	0	0	0	53
	Apr-13		0	0	0	53	0	0	0	53
	May-13		0	0	0	53	0	0	40	53
	Jun-13		0	0	0	0	0	0	40	40

			Stage							Total All Phases
			Phase 1 dB(A)	Phase 2 dB(A)	Phase 3 dB(A)	Phase 4 dB(A)	Phase 5 dB(A)	Phase 6 dB(A)	Phase 7 dB(A)	
Receptor	North of Azim Kend/Masiv	R8	95	97	103	103	103	97	91	
Distance (m)			3200	3000	2000	2000	2300	2000	2800	
Screening			0	0	0	0	0	0	0	
Plant at Boundary			50%	50%	50%	50%	50%	50%	50%	
Façade			3	3	3	3	3	3	3	
On Time %			50%	50%	50%	50%	50%	50%	50%	
<b>Noise level dB(A)</b>			<b>42</b>	<b>44</b>	<b>54</b>	<b>54</b>	<b>53</b>	<b>48</b>	<b>39</b>	
<b>R8</b>										
	Jan-12		42	44	54	0	0	0	0	55
	Feb-12		0	44	54	0	0	0	0	55
	Mar-12		0	44	54	54	0	0	0	57
	Apr-12		0	44	54	54	0	48	0	58
	May-12		0	0	54	54	0	48	0	58
	Jun-12		0	0	54	54	53	48	0	59
	Jul-12		0	0	54	54	53	48	0	59
	Aug-12		0	0	54	54	53	48	0	59
	Sep-12		0	0	0	54	53	48	0	57
	Oct-12		0	0	0	54	53	48	0	57
	Nov-12		0	0	0	54	0	48	0	55
	Dec-12		0	0	0	54	0	48	0	55
	Jan-13		0	0	0	54	0	48	0	55
	Feb-13		0	0	0	54	0	0	0	54
	Mar-13		0	0	0	54	0	0	0	54
	Apr-13		0	0	0	54	0	0	0	54
	May-13		0	0	0	54	0	0	39	54
	Jun-13		0	0	0	0	0	0	39	39

			Stage							Total All Phases
			Phase 1 dB(A)	Phase 2 dB(A)	Phase 3 dB(A)	Phase 4 dB(A)	Phase 5 dB(A)	Phase 6 dB(A)	Phase 7 dB(A)	
Receptor	Herder Settlement	R12	95	97	103	103	103	97	91	
Distance (m)			3600	2500	2500	2500	3900	4600	2900	
Screening			0	0	0	0	0	0	0	
Plant at Boundary			50%	50%	50%	50%	50%	50%	50%	
Façade			0	0	0	0	0	0	0	
On Time %			50%	50%	50%	50%	50%	50%	50%	
<b>Noise level dB(A)</b>			<b>38</b>	<b>43</b>	<b>49</b>	<b>49</b>	<b>46</b>	<b>38</b>	<b>35</b>	
<b>R12</b>										
	Jan-12		38	43	49	0	0	0	0	50
	Feb-12		0	43	49	0	0	0	0	50
	Mar-12		0	43	49	49	0	0	0	53
	Apr-12		0	43	49	49	0	38	0	53
	May-12		0	0	49	49	0	38	0	52
	Jun-12		0	0	49	49	46	38	0	53
	Jul-12		0	0	49	49	46	38	0	53
	Aug-12		0	0	49	49	46	38	0	53
	Sep-12		0	0	0	49	46	38	0	51
	Oct-12		0	0	0	49	46	38	0	51
	Nov-12		0	0	0	49	0	38	0	50
	Dec-12		0	0	0	49	0	38	0	50
	Jan-13		0	0	0	49	0	38	0	50
	Feb-13		0	0	0	49	0	0	0	49
	Mar-13		0	0	0	49	0	0	0	49
	Apr-13		0	0	0	49	0	0	0	49
	May-13		0	0	0	49	0	0	35	50
	Jun-13		0	0	0	0	0	0	35	35

# **Annex D: Piling and Concrete Breaking Noise Calculations**

BS5228 Reference Table C3 Item 3 Table C3 Item 1 Table C3 Item 29	Plant	Noise dB(A) at 10m	Trial Piling - 100m from North West Corner of SD2 EA			
			Scenario 1		Scenario 2	
			Qty	dB(A)	Qty	dB(A)
	Tubular Piling Rig	88	1	88	0	0
	Pre-Cast Concrete Piling Rig	89	0	0	1	89
	55 tonne Crane	70	1	70	1	70
<b>Total Noise at 10m</b>			88		89	
			Stage			
			Scenario 1	Scenario 2		
			dB(A)	dB(A)		
Receptor	Azim Kend	R1	88	89		
Distance (m)			2000	2000		
Screening			0	0		
Facade			3	3		
On Time %			100%	100%		
<b>Noise level dB(A)</b>			<b>45</b>	<b>46</b>		
	Sangachal	R2	88	89		
			2100	2100		
			0	0		
			3	3		
			100%	100%		
			<b>45</b>	<b>46</b>		
Receptor	Umid West	R3	88	89		
Distance (m)			3950	3950		
Screening			0	0		
Facade			3	3		
On Time %			100%	100%		
<b>Noise level dB(A)</b>			<b>39</b>	<b>40</b>		

BS5228 Reference Table C3 Item 3 Table C3 Item 1 Table C3 Item 29	Plant	Noise dB(A) at 10m	Trial Piling - 100m from South-West Corner of SD2 EA			
			Scenario 3		Scenario 4	
			Qty	dB(A)	Qty	dB(A)
	Tubular Piling Rig	88	1	88	0	0
	Pre-Cast Concrete Piling Rig	89	0	0	1	89
	55 tonne Crane	70	1	70	1	70
<b>Total Noise at 10m</b>			88		89	
			Stage			
			Scenario 3	Scenario 4		
			dB(A)	dB(A)		
Receptor	Azim Kend	R1	88	89		
Distance (m)			2300	2300		
Screening			0	0		
Facade			3	3		
On Time %			100%	100%		
<b>Noise level dB(A)</b>			<b>44</b>	<b>45</b>		
	Sangachal	R2	88	89		
			1200	1200		
			0	0		
			3	3		
			100%	100%		
			<b>49</b>	<b>50</b>		
Receptor	Umid West	R3	88	89		
Distance (m)			3500	3500		
Screening			0	0		
Facade			3	3		
On Time %			100%	100%		
<b>Noise level dB(A)</b>			<b>40</b>	<b>41</b>		

BS5228 Reference Table C3 Item 14 Table D2 Item 7 Table D3 Item 101	Plant	Noise dB(A) at 10m	Bored Piling, Pipe Crossing - Location South			
			Scenario 1			
			Qty	dB(A)	Qty	dB(A)
	Large Rotary Bored Piling Rig	88	3	93	0	0
	Pneumatic Hammer	92	3	97	0	0
	Air Compressor	85	1	85	0	0
	<b>Total Noise at 10m</b>			<b>98</b>		<b>0</b>
				Stage		
				Scenario 1 dB(A)	0 dB(A)	
Receptor	Azim Kend	R1		98	0	
Distance (m)				2400	1	
Screening				0	0	
Façade				3	3	
On Time %				100%	100%	
<b>Noise level dB(A)</b>				<b>54</b>	<b>0</b>	
	Sangachal	R2		98	0	
				1200	1	
				0	0	
				3	3	
				100%	100%	
				<b>60</b>	<b>0</b>	
Receptor	Umid West	R3		98	0	
Distance (m)				2900	1	
Screening				0	0	
Façade				3	3	
On Time %				100%	100%	
<b>Noise level dB(A)</b>				<b>52</b>	<b>0</b>	

BS5228 Reference Table C3 Item 14 Table D2 Item 7 Table D3 Item 101	Plant	Noise dB(A) at 10m	Bored Piling, Pipe Crossing - Location South-East			
			Scenario 2			
			Qty	dB(A)	Qty	dB(A)
	Large Rotary Bored Piling Rig	88	3	93	0	0
	Pneumatic Hammer	92	3	97	0	0
	Air Compressor	85	1	85	0	0
	<b>Total Noise at 10m</b>			<b>98</b>		<b>0</b>
				Stage		
				Scenario 2 dB(A)	0 dB(A)	
Receptor	Azim Kend	R1		98	0	
Distance (m)				3000	1	
Screening				0	0	
Façade				3	3	
On Time %				100%	100%	
<b>Noise level dB(A)</b>				<b>52</b>	<b>0</b>	
	Sangachal	R2		98	0	
				1500	1	
				0	0	
				3	3	
				100%	100%	
				<b>58</b>	<b>0</b>	
Receptor	Umid West	R3		98	0	
Distance (m)				2300	1	
Screening				0	0	
Façade				3	3	
On Time %				100%	100%	
<b>Noise level dB(A)</b>				<b>54</b>	<b>0</b>	



BS5228 Reference Table D2 Item 6 Table C1 Item 14	Plant	Noise dB(A) at 10m	Concrete Breaking - no screening			
			Scenario 1		Scenario 2	
			Qty	dB(A)	Qty	dB(A)
	Breaker	96	1	96	0	0
	Crusher	82	1	82	0	0
			0	0	0	0
	<b>Total Noise at 10m</b>			<b>96</b>		<b>0</b>
				Stage		
				Scenario 1	Scenario 2	
				dB(A)	dB(A)	
Receptor	Azim Kend	R1		96	0	
Distance (m)				2500	1	
Screening				0	0	
Façade				3	3	
On Time %				100%	100%	
<b>Noise level dB(A)</b>				<b>51</b>	<b>0</b>	
	Sangachal	R2		96	0	
				1540	1	
				0	0	
				3	3	
				100%	100%	
				<b>55</b>	<b>0</b>	
Receptor	Umid West	R3		96	0	
Distance (m)				3270	1	
Screening				0	0	
Façade				3	3	
On Time %				100%	100%	
<b>Noise level dB(A)</b>				<b>49</b>	<b>0</b>	

BS5228 Reference Table D2 Item 6 Table C1 Item 14	Plant	Noise dB(A) at 10m	Breaking with Local Screen			
			Scenario 2		Scenario 3	
			Qty	dB(A)	Qty	dB(A)
	Breaker	96	1	96	0	0
	Crusher	82	1	82	0	0
			0	0	0	0
	<b>Total Noise at 10m</b>			<b>96</b>		<b>0</b>
				Stage		
				Scenario 2	Scenario 3	
				dB(A)	dB(A)	
Receptor	Azim Kend	R1		96	0	
Distance (m)				2500	1	
Screening				-5	0	
Façade				3	3	
On Time %				100%	100%	
<b>Noise level dB(A)</b>				<b>46</b>	<b>0</b>	
	Sangachal	R2		96	0	
				1540	1	
				-5	0	
				3	3	
				100%	100%	
				<b>50</b>	<b>0</b>	
Receptor	Umid West	R3		96	0	
Distance (m)				3270	1	
Screening				-5	0	
Façade				3	3	
On Time %				100%	100%	
<b>Noise level dB(A)</b>				<b>44</b>	<b>0</b>	

## **APPENDIX 9E**

### **Summary of Surface Water Modelling**



## 1 Introduction

This Appendix presents a summary of the results obtained from the hydrological water modelling studies completed in the vicinity of the Terminal by Water Resource Associates (WRA) during 2008, 2010 and 2011.

The summary presented describes the current hydrological regime in the vicinity of the Terminal, the methods used for hydrological modelling (for current conditions and with the SD2 Infrastructure Project) and the results of the modelling studies. Findings associated with the future flood risk at key receptors, and the potential for cumulative impacts associated with upstream development of the proposed Qizildas Cement Plant are also presented. Where relevant, the uncertainty associated with model input and output data is discussed.

### 1.1 Hydrology in the Vicinity of the Sangachal Terminal

Sangachal Terminal is located approximately 30 km south of Baku, north east of Sangachal Town and lies within a dry area of Azerbaijan where annual average rainfall is about 220-250 mm. The amount of rainfall received varies significantly from year to year.

Hydrology in the vicinity of the Terminal is complex due to its position within a number of drainage catchment areas (refer to Figure 1.1) which are:

- Shachkaiya catchment areas (the Shachkaiya Wadi and its western tributaries);
- Northern and western perimeter catchment areas;
- Mt Qaraqush catchment areas which comprise:
  - Western Qaraqush slopes and north east perimeter channel;
  - Central Qaraqush slopes and Umid Wadi outlet; and
  - Flood storage areas between Sangachal Terminal and railway embankment.

During the 2010 modelling study catchment areas were divided into 23 sub-catchment areas to allow drainage of the Terminal to be characterised within a detailed hydrological model. The Terminal is directly affected by runoff from sub-catchments 'nw1', 'nw2' and 'nw3' to the west and northwest and 'q81', 'q9' and 'q91' which lie to the northeast and east of the Terminal (refer to Figure 1.1). Catchments 'q7', 'q8' and 'q82' drain the western slopes of Mt Qaraqush and enter flood storage area 'RES2' through culverts (denoted as B1 and B2 in Figure 1.1) beneath the existing Terminal access road.

Floodwaters around the existing Terminal are currently diverted into the perimeter flood protection channel. This situation will be modified by the SD2 Infrastructure Project which occupies a large part of what is shown as sub-catchment 'nw3' on Figure 1.1. The catchment area within the vicinity of the Terminal is 137 km<sup>2</sup> which includes low-lying areas to the south east along the third party pipeline corridor. The catchment area has two outlets which pass through the railway embankment and coastal highway:

- Bridge 'B4' under the railway and culvert B6 under the highway to the south close to Sangachal Town; and
- Bridge 'B3' under the railway and culvert B9 beneath the highway midway between Sangachal Town and the current terminal access road (see Figure 1.2).

The third party pipeline corridor and railway embankment provide a barrier to outflow from the Shachkaiya Wadi and other surface water drainage channels.

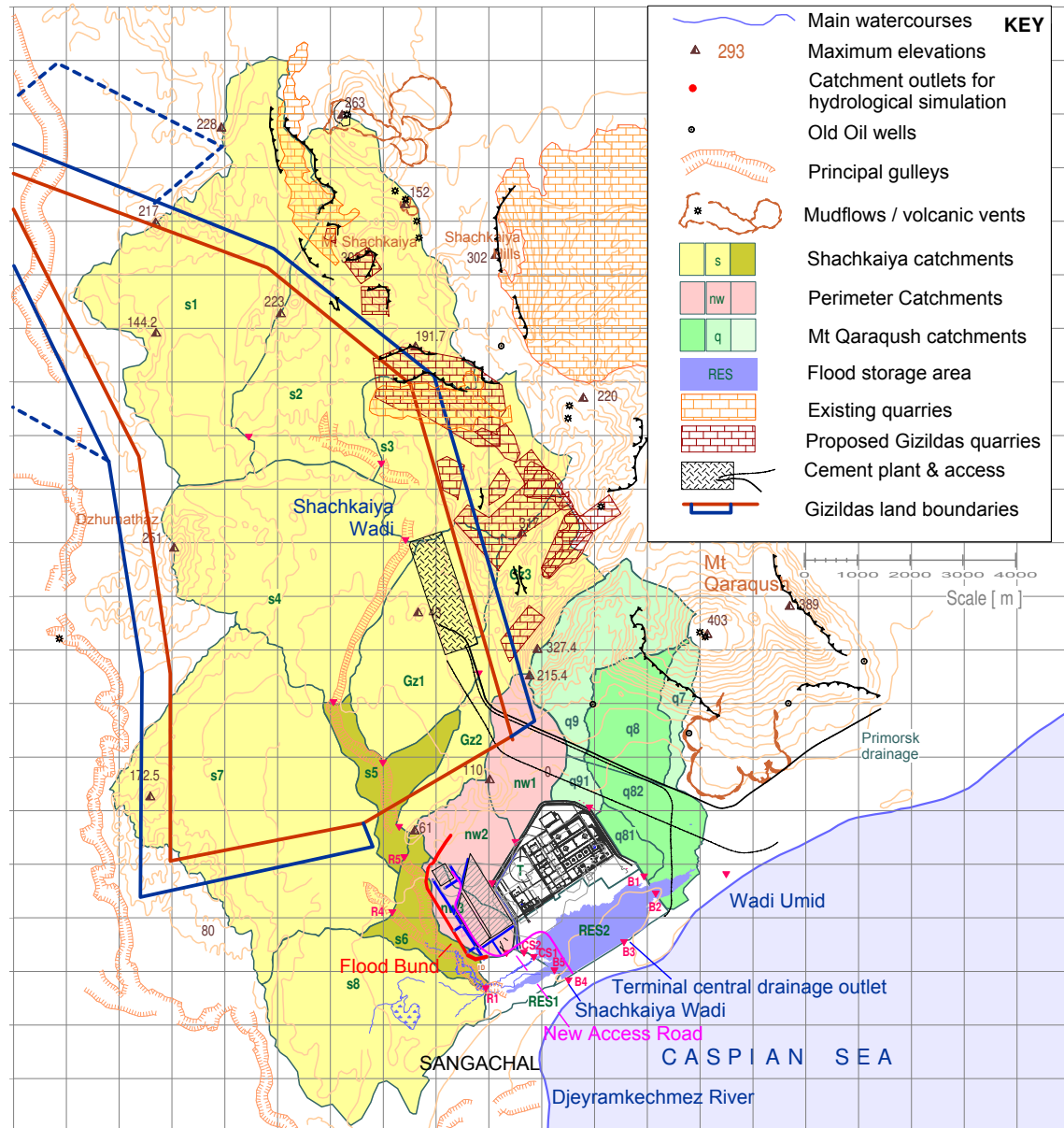

© Water Resource Associates Ltd. Based on Soviet mapping at 1:50,000 scale and satellite imagery, with WRA data added.

**Figure 1.1 Main Drainage Catchment Areas in the Vicinity of the Terminal**

## 1.2 Proposed Qizildas Cement Plant

The proposed Qizildas Cement Plant is located in the upper catchment area of the Shachkaiya Wadi. It is understood that activities will include the quarrying of limestone within the catchment to be used in the cement production process. This upstream development, and potentially other industrial activities, have the potential to increase the level of flood risk at key receptors located downstream. At the time of writing, exact details and extent of these proposed developments were not known and a rough boundary of the proposed Qizildas Cement Plant is shown in Figure 1.1.

## 1.3 Scope of Hydrological Modelling Studies

The scope of hydrological modelling studies undertaken in the vicinity of the Terminal are summarised below:

1. Sangachal Terminal, Surface and Subsurface Water and Landscape Management, Scoping Study (WRA, 2008a). This study was carried out to ensure that the capacity of the perimeter drainage channels for the Terminal was sufficient to cope with a major flood event, and to investigate flood risk to Terminal facilities represented by the third party pipeline corridor. This Scoping Study comprised a desk study using existing data and did not involve the development of a new (or existing) hydrological model.
2. Sangachal Terminal Phase 2 Expansion, Surface Water Study, Stage 2 (WRA, 2008b). A hydrological modelling study of the disturbed drainage area within the third party pipeline corridor was undertaken. This Surface Water Study also supported the selection of access road options for construction of the SD2 Infrastructure Project (refer to Figure 1.2). The study findings were used to inform access road embankment heights and dimensions of culverts beneath various construction and access routes to the SD2 Infrastructure area. Hydrological modelling was undertaken using 'HEC-RAS' software and used rainfall data recorded at three meteorological stations within the region from 1992 to 2006.
3. Sangachal Terminal Phase 2 Expansion, Additional Surface Water Studies. (WRA, 2010). Further modelling of potential access road options was undertaken in 2010. The purpose of the report was to provide drainage advice and support to the SD2 Infrastructure design consultant. Additional study objectives included determining river flow data for annual maximum floods from three rivers within the region. Based on this information the SD2 Infrastructure design contractor selected a single route (refer to Figure 1.3).
4. Sangachal Terminal Phase 2 Expansion, Hydrological modelling in support of detailed design for the flood protection & drainage works (WRA, 2011). This study established the appropriate embankment height for the selected access road route and investigated culvert dimension options, where the road crosses the third party pipeline corridor (refer to point 'B8' on Figure 1.3). Further details of this work are given in Section 3.2 of this report. This study also provided guidance to the SD2 Infrastructure design contractor, on sizing of drainage channels and culverts within the new SD2 Infrastructure area (referred to as the 'subsidiary drainage system'). The study also provided design heights for a western flood protection berm for the SD2 Infrastructure area.

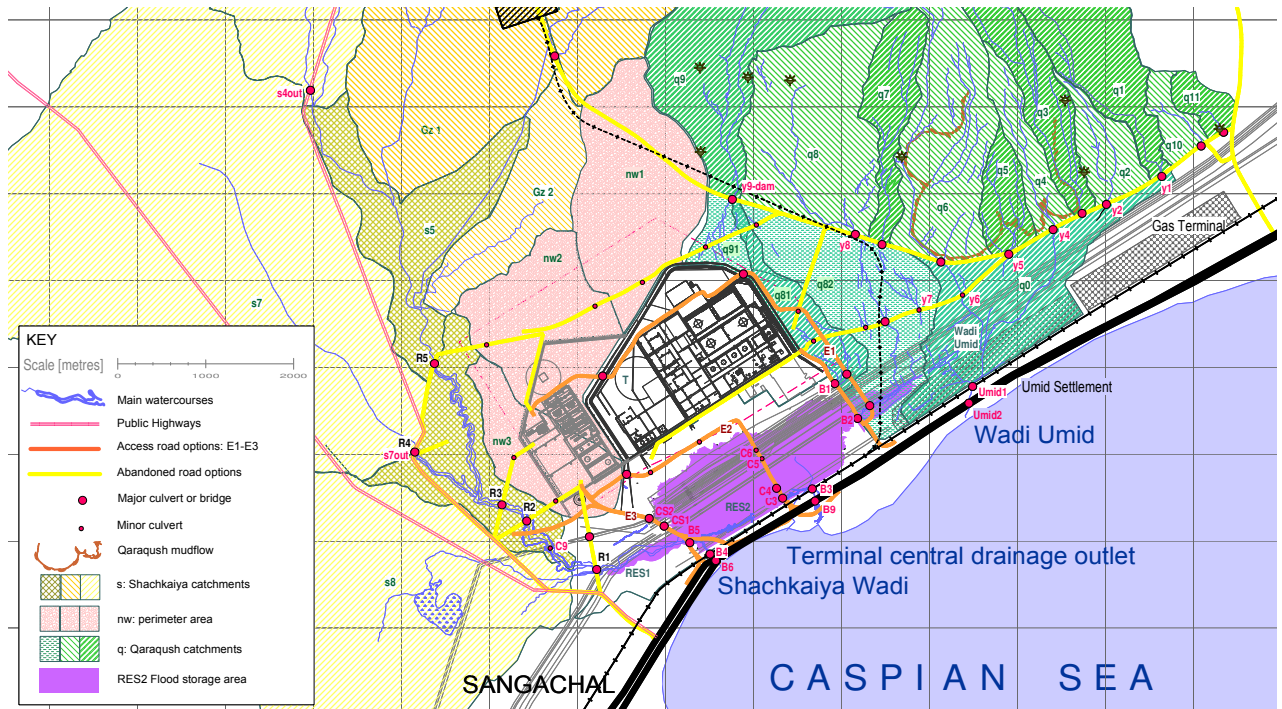

© Water Resource Associates Ltd. Based on Soviet mapping at 1:50,000 scale and satellite imagery, with WRA data added.

**Figure 1.2 Revised Access Road Options Studied (WRA, 2010)**

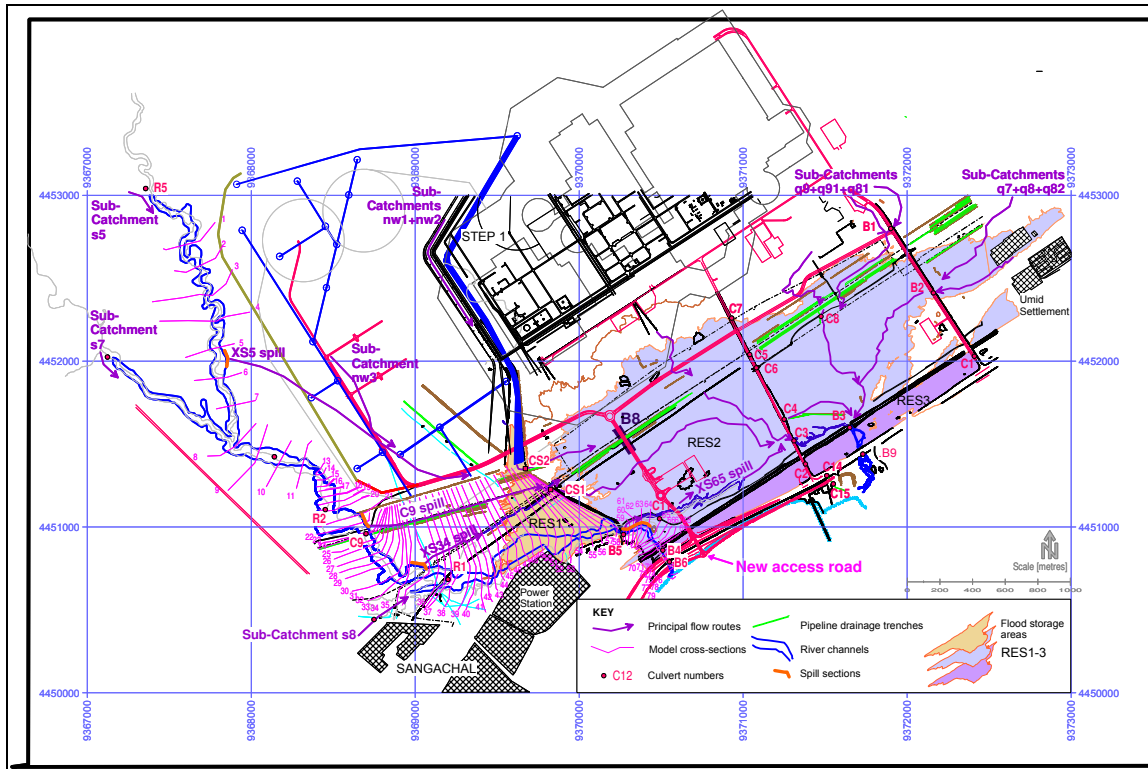

© Water Resource Associates Ltd. Based on Soviet mapping at 1:50,000 scale and satellite imagery, with WRA data added.

**Figure 1.3 Principal Flow Routes Following SD2 Infrastructure Works and Final Access Road Layout**

## 2 Modelling Methodology

### 2.1 Available Data

Hydrological modelling used a combination of statistical analysis of annual maximum flows from river gauging stations, local-rainfall data and a unit hydrograph approach to estimate flood hydrographs and runoff volumes.

#### 2.1.1 Rainfall Data

Rainfall data was obtained from three meteorological stations located at Baku Airport, Alyat and at Mashtaga (refer to Figure 2.1). Daily rainfall data from 1977 to 2006 was obtained from for Baku and Alyat; rainfall data was obtained for Mashtaga between 1992 to 2006.





**Figure 2.1 Rainfall Stations in the Absheron Region**

Figure 2.2 shows the data at these stations for years 1992-2006 and although the three rainfall stations lie in Absheron region’s coastal corridor, rainfall at Mashtaga is significantly higher than the rainfall at the other two sites. It is expected that the rainfall at Alyat and Baku will be more representative of the conditions at the Terminal (compared with Mashtaga), being in the rain shadow of the eastern end of the Caucasus Mountains. Consequently, the rainfall data from Mashtaga was not used. Some rainfall data is missing and marked as ‘m’ in Figure 2.2.

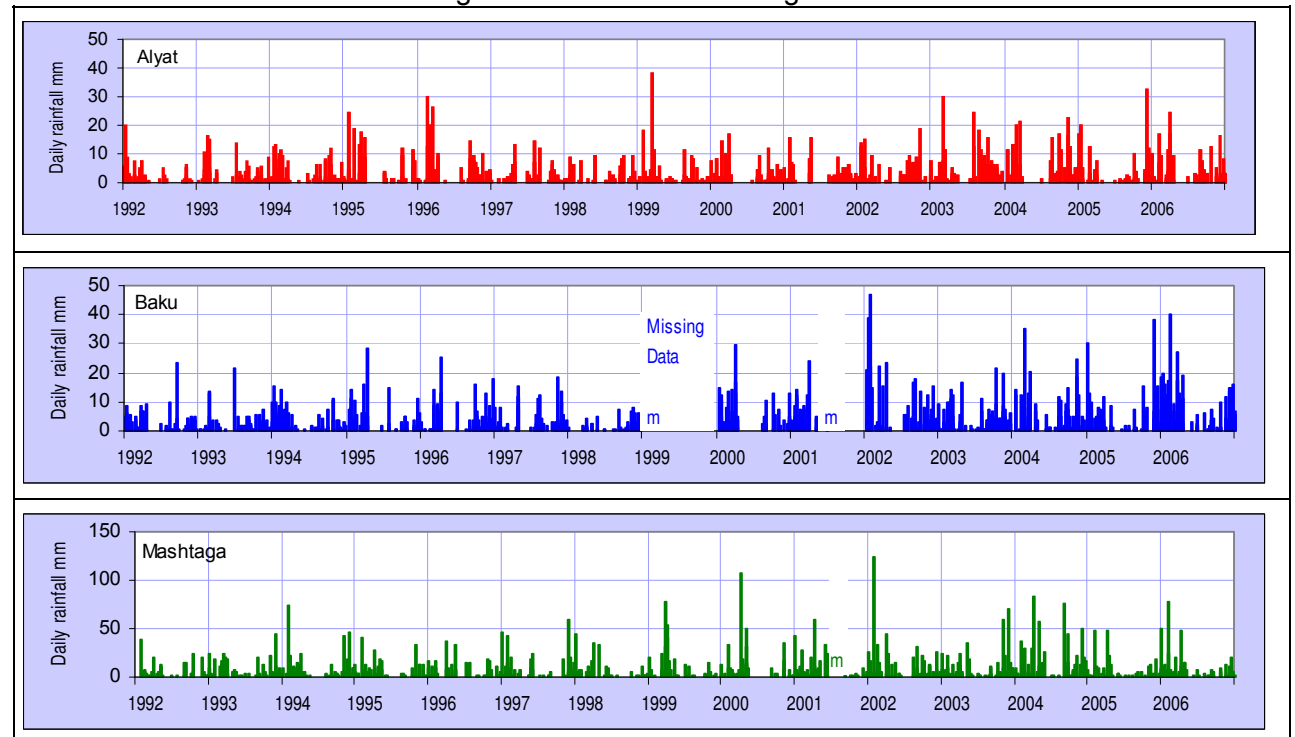

**Figure 2.2 Daily Rainfalls in the Absheron Region**

The National Meteorological Service provided daily rainfall data and flood return periods for 2008 which indicated that the 100-year, 24-hour rainfall value was 70 mm. A statistical analysis on 1977-2006 daily rainfall obtained from meteorological stations at Alyat and Baku was completed by WRA (2008b) using the statistical method of Gumbel and Log-Normal distribution. Results from Baku were subsequently incorporated into the hydrological model. The Log-Normal analysis produced a rainfall value of 72.4mm for the 100-year 24-hour rainfall; this is equivalent to an average rainfall intensity of 3.02 mm/hr. The Gumbel analysis produced a major flood event rainfall value of 66mm; this was lower than expected and not used in the hydrological model.

## 2.1.2 Surface Water Flow Data

A review of available data was undertaken and annual maximum flow data was obtained for the following surface water features: Djeyramkecmez (located immediately to the south of the Shachkaiya Wadi and shares a watershed with sub-catchments 's1' to 's8'), Sumqayit, and Pirsaat (refer to Table 2.1).

**Table 2.1 Annual Maximum Flood Data Obtained**

River	Flow Gauging Station	Area km <sup>2</sup>	Number of Years Available	Years of Annual Maximum Flood Data Available	Mean Annual Flood (m <sup>3</sup> /s)
Djeyramkecmez	Sangachal	1,170	14	1938-42, 1952-56, 1965-69	42.1
Djeyramkecmez	Umbaki	412	4	1957-58, 1960-61	12.4
Sumqayit	Perekeskül	1500	30	1937, 1939-40, 1942, 1958-75, 1976-85	77.8
Pirsaat	Poladli	995	21	1966, 1968-87	76.2
Pirsaat	Jassi	648	4	1937-38, 1940-41	26.8
Pirsaat	Zarat-Yeyberi	58	3	1961-63	2.88
Pirsaat	Sosseydiy Mocom	407	9	1953-56, 1958, 1860-63	41.2

## 2.2 Regional Flood Frequency Estimation

The problem associated with data gaps within the annual maximum flood data was addressed through the application of a statistical approach that estimates flood return periods. This approach (referred to as a Flood Frequency Analysis) essentially substitutes data gathered at gauging stations from other parts of the region or country which has similar climatic and catchment conditions. This can provide reliable estimates of major flood events.

There are limitations to the Flood Frequency Analysis approach. For example, where short periods of data exist (for 'N' number of years) the approach can only reliably estimate annual maximum flows for a return period of '2\*N' years. Consequently, the 50 year return period for surface water features: Sumqayit at Perekeskül and Pirsaat at Poladli could be estimated. Estimation of the 100 year return period was not possible using the Flood Frequency Analysis approach due to the short periods of data available.

The Mean Annual Flood (MAF) value reflects the average of peak stream flows covering the timeseries data available. A variety of MAF values were taken from gauging stations located in western and central Azerbaijan as reported by Sutcliffe *et. al.*, (2008). A total of 859 years of MAF data from 29 flow gauging stations was taken from Sutcliffe *et. al.*, (2008) and combined with 85 years of data from the seven gauging stations collected by

WRA in 2010. The statistical relationship between LogMAF and LogAREA (catchment area) was subsequently investigated and the results are illustrated in Figure 2.3. Sangachal catchments are shown in red colour and data recorded from gauging stations elsewhere in Azerbaijan are shown in blue colour.

The correlation between flow gauging stations for Sangachal catchments and other stations in the region indicates that there is a broadly similar relationship between LogMAF and LogAREA. On this basis, MAF data was used to fill time periods in surface water flow, with model input data providing a reasonable level of confidence.

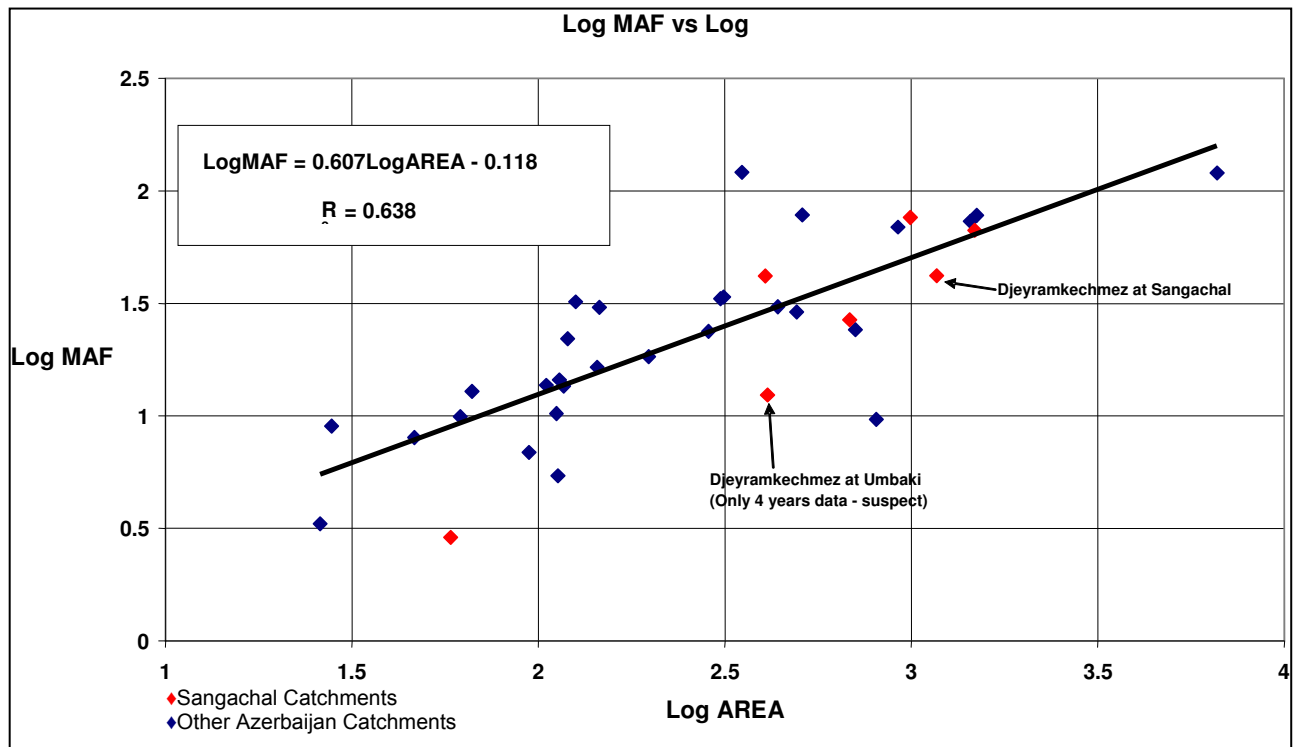

**Figure 2.3 Relationship Between LogMAF and LogAREA for Sangachal Catchments (red) and regional data (blue)**

Sutcliffe *et al.* (2008) also provides flood frequency curves for Azerbaijan where MAF data may be calculated to provide flood estimates 'Q(T)' for a range of return periods (T years). Using the flood frequency curves, flood peak discharge data can be calculated for each sub-catchment of interest (refer to Table 2.2). This approach combines uncertainty associated with Flood Frequency Analysis and in the use of flood frequency curves taken from Sutcliffe *et al.* (2008). Nevertheless, the preliminary flood estimates derived for a range of return periods provides useful flood values that reflects the maximum use of the data available. The flood peak discharge estimates in Table 2.2 can be used as a calibration in hydrological modelling and support subsequent flood estimation calculations.

**Table 2.2 Flood Peak Discharge Based on Mean Annual Flood**

Sub-catchment Reference	Area Name	Area (km <sup>2</sup> )	Mean Annual Flood (m <sup>3</sup> /s)	Peak Flood Discharge in m <sup>3</sup> /s for given Return Period			
				Q(10)	Q(25)	Q(50)	Q(100)
s1-6	Shachkaiya Wadi	73.81	10.37	20.32	32.25	44.69	61.17
s7	Cexamud tributary	20.06	4.70	9.22	14.63	20.27	27.75
s8	Komplex CIR / Sangachal	9.99	3.08	6.04	9.58	13.27	18.17
nw1	Military Post - CPC North	3.56	1.65	3.23	5.12	7.10	9.72
nw2	Military Post - CPC Centre	2.12	1.20	2.36	3.74	5.18	7.09
nw3	WPC post phase 2	2.50	1.33	2.60	4.13	5.73	7.84
q9+q91	Qaraqush NPC	6.33	2.34	4.58	7.26	10.06	13.78
q8+q81+q82	Qaraqush B1+B2	6.89	2.46	4.82	7.65	10.60	14.51
T	Terminal area 1 (Ph1+2)	4.73	1.96	3.83	6.08	8.43	11.54
RES1	Shachkaiya Marshes	3.05	1.50	2.94	4.66	6.46	8.85
RES2	Central Drain floodplain	4.08	1.79	3.51	5.56	7.71	10.55
<b>TOTAL</b>		<b>137.12</b>					

### 2.3 Flood Hydrograph Estimation

Flood hydrographs were used to evaluate the extent of flood risk associated with temporary storage within the third-party pipeline corridor at 'RES1' and 'RES2' (see Figure 1.3). These locations allow surface water following high intensity rainfall events to be stored (or retained) behind drainage culverts during peak flow conditions.

A unit hydrograph method was used to derive streamflow hydrographs that reflect high-intensity rainfall events within catchments. The unit hydrograph of any catchment reflects runoff generated by a 'unit' of rainfall in a 'unit' period of time. For catchments which have limited data available, unit hydrograph parameters can be estimated using a range of calculation methods that link unit hydrograph time to peak 'Tp'; stream length 'L'; and slope 'S'. The most widely used formulae are those of Kirpich (1940), US Soil Conservation Service (SCS) (1986), and the UK Flood Studies Report (FSR) (1975). These formulae are shown below:

$$T_{p(\text{Kirpich})} = 0.0195 L^{0.77} S^{-0.385}$$

where 'L' is stream length in m; and 'S' is slope in m/m.

$$T_{p(\text{SCS})} = 0.00526 L^{0.8} (1000/\text{CN} - 9)^{0.7} S^{-0.5}$$

where 'L' is length in ft; 'S' is slope in ft/ft; and 'CN' the runoff curve number.

$$T_{p(\text{FSR})} = 2.8(L/\sqrt{S})^{0.47}$$

where 'L' is stream length in km; and 'S' is stream slope in m/km.

Each of the three equations above are suited to different types of catchment. For example, the FSR and Kirpich method are designed for catchments with an area greater than 20km<sup>2</sup>, whilst the SCS equation was developed for smaller catchments. Consequently, TP estimates were used as a rough average of the FSR and Kirpich method where catchments area was greater than 20 km<sup>2</sup>, and the FSR and SCS methods was used for smaller catchments.

The 2011 WRA study calculated flood hydrographs for different storm durations (6, 12, 18, 24, 36, 48 and 72 hours). Two 'indicator' catchments were also used to calculate flood hydrographs which were the largest sub-catchment (Shachkaiya Wadi) and a combination of two smaller sub-catchments ('nw1' and 'nw2').

The results of the analysis of peak flood and flood volume for each indicator catchment are shown in Table 2.3 and indicates the larger Shachkaiya Wadi catchment is more sensitive to longer duration storms (18 to 24 hours), compared with the smaller sub-catchments (12 to 18 hours). The minimum duration of a storm that could result in flood risk was calculated (often called the 'critical storm duration') at 18 hours and this was used in hydrological modelling to define the major flood event.

**Table 2.3 Results of Storm Duration Trials**

Duration (hrs)	Flood Peaks for Return period (years)				Flood Volumes for Return period (years)			
	(Flows in m <sup>3</sup> /sec)				(Volumes in Million m <sup>3</sup> )			
	10	20	50	100	10	20	50	100
<b>(i) Shachkaiya Wadi</b>								
6	26.2	31.6	39.3	45.5	1.18	1.4	1.72	1.98
12	29.9	36.4	45.4	52.6	1.48	1.74	2.12	2.42
18	33.5	40.8	51.8	60.9	1.84	2.14	2.59	2.97
24	32.4	40	50.9	60.1	2.05	2.36	2.81	3.19
36	29.9	37.7	49.6	60	2.59	2.89	3.38	3.82
48	26.9	34.6	46.5	56.7	3.14	3.45	3.92	4.35
72	21.6	28.2	38.8	51.3	4.24	4.48	4.89	5.4
<b>(ii) Central Perimeter Channel</b>								
6	10.8	13.3	16.9	19.8	0.087	0.106	0.133	0.154
12	10.2	13	16.9	20.1	0.103	0.125	0.156	0.181
18	9.5	12.3	16.4	19.9	0.117	0.14	0.176	0.206
24	8.8	11.6	15.7	18.9	0.13	0.156	0.194	0.225
36	7.1	9.6	13.3	16.5	0.156	0.181	0.222	0.258
48	5.7	7.9	11.1	13.9	0.182	0.207	0.246	0.282
72	3.5	5.1	7.3	9.9	0.235	0.256	0.288	0.33

For catchments where no river gauging data was available, the percentage of incoming storm rainfall that produces runoff was estimated using an approach outlined by the US Soil Conservation Service (1986). This approach uses a 'curve number' (CN) to reflect the relationship between rainfall and runoff which is a function of soil type and land cover. To identify a representative CN-value the 14 years annual maximum flood flow data for Djeyramkeczmez at Sangachal, and the Azerbaijan flood frequency curves of Sutcliffe *et al.* (2008) were used.

Using the 100 year, a 24-hour design storm rainfall value of 72 mm and estimated unit hydrograph, various CN-values were varied empirically, until the resulting hydrograph peak matched the 100 year flood peak of 61.17 m<sup>3</sup>/s predicted for the Shachkaiya Wadi (s1-6) (refer to Table 2.2). The optimum fit between hydrograph peaks was achieved using a CN value of 78. This uses a variable runoff percentage for different storm durations from 57% for a 6 hour storm, to 41% for a 72 hour storm. The percentage runoff for the recommended 18 hour storm was 48%, and for the 24 hour storm was 46%. The CN value of 78 was subsequently applied across all the sub-catchments as the computed runoff rate seemed reasonable for catchments visually inspected during site visits.



### 2.3.1 Climate Change Effects on Runoff Volumes

In order to reflect the way in which climate change could influence flood risk in the future through changes in the distribution and intensity of rainfall events, BP commissioned a report from Dr Ralph Toumi from Imperial College London. The report entitled: '*BP Climate Change Impact Project: Interim Report*' (January 2011) aimed to identify the flood-related consequences of climate change. The report concludes that the expected change in 100 year daily rainfall for Sangachal region from 2040 to 2060 was an increase of 10%. Whilst considerable uncertainty is associated with the 10% increase, the report recommended that historical storm data should be increased by 10% for hydrological flood modelling studies to reflect the consequences of climate change. The model input data was modified accordingly.

Rainfall distribution was identified through a combination of reviewing storm profiles from other arid regions and using the 90% summer rainfall profile from the FSR. The design storm rainfall was subsequently applied to each sub-catchment unit hydrograph using a CN value of 78, and the resulting peaks and runoff volumes are shown in Table 2.4.

**Table 2.4 FSR-SCS Flood Peaks and Volumes for the 100 Year Event**

Sub-catchment No	Catchment Area Name	Area km <sup>2</sup>	Mean Annual Flood (m <sup>3</sup> /s)	Q100 Hydrograph Peak (m <sup>3</sup> /s)	Q100 Regional Equation peak(m <sup>3</sup> /s)	Total Flood Volume (m <sup>3</sup> )
s1-6 + Gz1 – Gz3	Shachkaiya Wadi	73.15	10.20	60.89	61.17	2,969,995
s7	Cexamud tributary	20.06	4.70	22.79	27.75	766,378
s8	Komplex CIR / Sangachal	9.99	3.08	14.28	18.17	371,852
nw1 + nw2	Drainage to CPC	5.96	2.25	20.93	13.96	210,274
q9 + q91	Qaraqush NPC	6.33	2.34	14.70	13.78	227,375
q8 + q81 + q82	Qaraqush B1+B2	6.89	2.46	12.12	14.51	251,965
T (Ph 1)	Terminal area 1 (Phase 1 only)	3.32	1.58	16.24	9.31	128,209
SD2	Phase 2 Terminal	1.94	1.14	8.83	6.72	70,421
RES1	Western flood storage area	3.05	0.84	15.63	8.85	123,246
RES2	Central Drain floodplain	4.08	1.79	34.21	10.55	239,350
<b>Total inflow to Flood storage areas and flowing out through B3 and B4</b>		<b>137.12</b>	<b>n/a</b>	<b>112.23*</b>	<b>89.1**</b>	<b>5,359,065</b>

\* Note: The peaks do not coincide so this figure is not the sum of individual sub-catchment peak flows

\*\* Derived from Eqn-1 plus regional growth curves and not sum of peaks

Generally, the 100 year flood estimates derived by the unit hydrograph method shown are consistent with those derived from use of the MAF approach and, also, flood frequency curves from Sutcliffe *et al.* (2008). Inconsistent results were obtained from the Terminal and flood storage areas 'RES1' and 'RES2' where the unit hydrograph approach produced significantly higher peak flows. This was expected as the runoff coefficient used on these largely impermeable areas was greater than the predominantly rural areas used in the MAF approach calculations.

The flood volume estimates given in Table 2.2 were calculated by converting rainfall

to runoff and this data for each sub-catchment was used in the hydrological modelling study. Based on the results, the total 100 year flood volume channelled through the Shachkaiya Wadi and central drainage outlets will be 5.36 Mm<sup>3</sup>, divided amongst the various sub-catchments.

The resulting sub-catchment hydrographs are shown in Figure 2.4 for a major flood event.

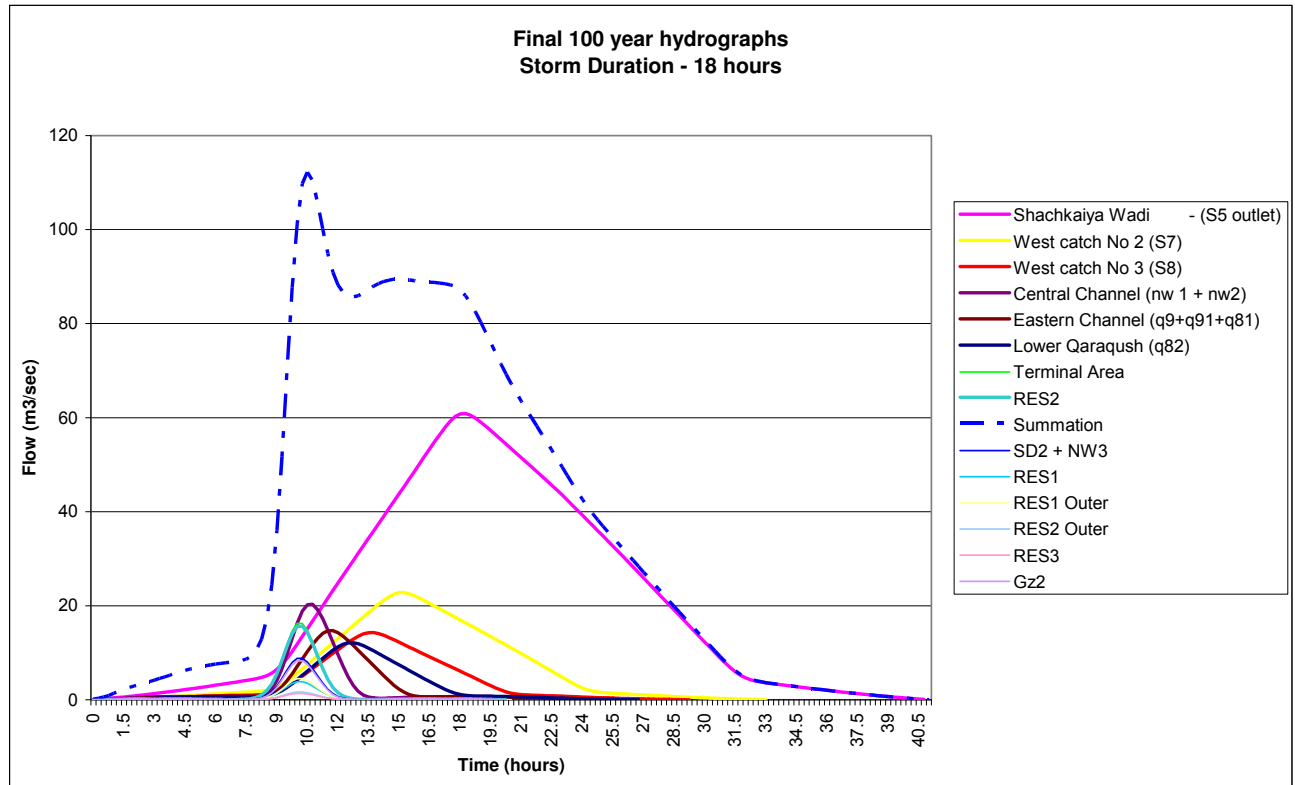

**Figure 2.4 FSR-SCS Flood Hydrographs for Existing Conditions – 18 Hour Duration Storm**

## 2.4 Hydrological Modelling

The WRA December 2008 (WRA, 2008b) report used ‘HEC-RAS’ hydrological model which was configured using results of a 2003 Shah Deniz topographic survey between the Terminal and Caspian Sea. The 2010 and 2011 WRA studies were undertaken using ISIS Pro v3.4 software. Annex 1 gives further details of the ISIS software and its applicability.

A field survey and visual inspection of surface water drainage flows in April 2010 assisted development of the hydrological model. As a result of the field survey, the Shachkaiya Wadi was represented as a linear flood corridor with channels and margins accurately derived from the field survey and supporting maps. The Shachkaiya corridor has a number of spill sections which permits water to move into areas defined by topographic depressions.

Upstream of the railway line there are two ‘off-line’ storage reservoirs that are separated by a prominent NW-SE trending earth embankment that continues from the end point of the CPC at ‘CS2’ outlet to ‘B5’ bridge (refer to Figure 1.3). The area upstream of the new access road embankment ‘RES1’ will maintain higher flood

levels in front of the planned SD2 Infrastructure area. The outflow from 'RES1' is controlled by the dimensions of two openings: the 'B8' box culvert beneath the new access road and the railway bridge 'B4'. The volumetric storage in this area was estimated to be 0.751 Mm<sup>3</sup> at -15 m mean seal level (MSL).

The central flood storage area 'RES2' acts as a large, flood attenuation lake and the relationship between elevation and storage has been calculated from field survey data. Although the third party pipeline corridor and associated trenches act as partial obstacles to flow, they also cause dispersal flows to merge as they enter the storage area. These obstacles also divert outflow from the Terminal and perimeter channels along the northerly of the Shachkaiya overspill routes at 'C9' and 'S34'. The volumetric storage in this area was calculated to be 1.848 Mm<sup>3</sup> at -17 m MSL.

Finally, water passing under the railway enters a narrow strip of low-lying land which provides further floodwater storage 'RES3' controlled by the outlet capacity of the culverts under the coastal highway at 'B9' (previously called 'C16') and 'B6'. The volumetric storage capacity of this area was calculated to be 0.249 Mm<sup>3</sup> at -17 m MSL.

The ISIS model layout is reflected in Figure 2.6 which illustrates the following:

- Flow directions indicated by blue arrows;
- Hydrograph inputs are labelled 'H1-13' and shown in green colour;
- Bridges and culverts are labelled 'B1-9' and shown in pink colour;
- Spills, where water will overtop the banks of the main channel are labelled 'SP1-6' and shown in light blue; and
- Reservoirs where flood water will be temporarily stored are labelled 'RES1-3' and shown in dark blue.

A summary of the drainage structures are listed in Table 2.5.



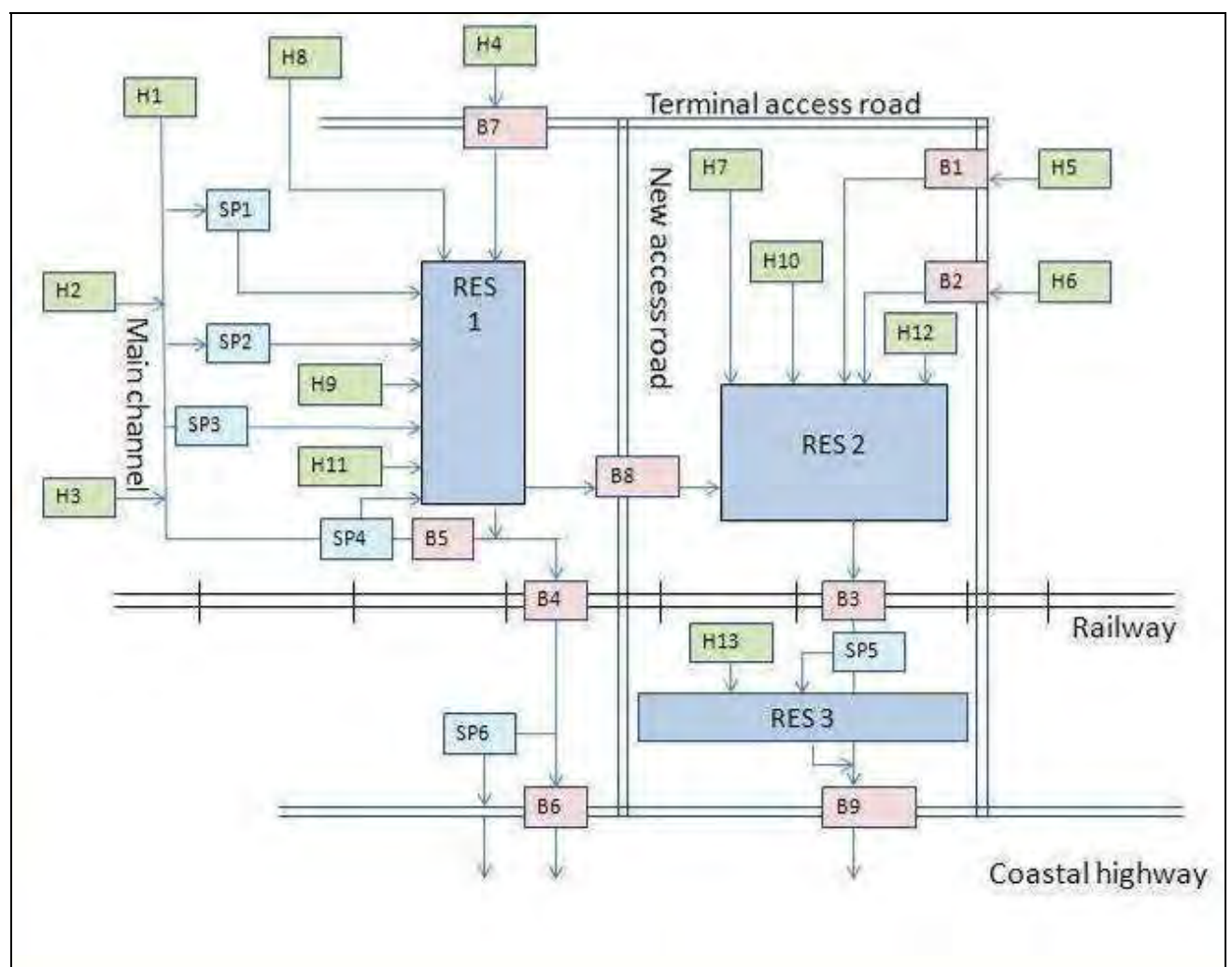

© Water Resource Associates Ltd.

Figure 2.5 ISIS Model Schematic

**Table 2.5 Definitions of Hydrographs, Bridges and Spills in the Model Schematic.**

*Text in brackets represents earlier or alternative labels for the same feature.*

Hydrograph Number	Description	Bridge Number	Description
H1	Shachkaiya Wadi (S5 outlet)	B1	Terminal access road bridge
H2	West Catchment No 2 (S7)	B2	Terminal access road bridge
H3	West Catchment No 3 (S8)	B3	Railway bridge
H4	Central Perimeter Channel (nw 1 + nw2)	B4	Railway bridge near Sangachal Town
H5	Eastern Perimeter Channel (q9+q91+q81)	B5	Old access road bridge
H6	Lower Qaraqush (q82)	B6	Coastal highway bridge near Sangachal Town
H7	Terminal Area	B7	New access road bridge (BRC5 on option E3 in previous study)
H8	Subsidiary Drainage (essentially nw3 in previous study)	B8	New access road bridge (BRC3 on option E3 in previous study)
H9	Reservoir 1 direct rainfall	B9	Coastal highway bridge (C16)
H10	Reservoir 2 direct rainfall		
H11	Reservoir 1 outer area		
H12	Reservoir 2 outer area		
H13	Reservoir 3 direct rainfall		
Spill Number		Description	
SP1	Main channel spill to reservoir 1 (XS5 spill)		
SP2	Main channel spill to reservoir 1 (C9 spill)		
SP3	Main channel spill to reservoir 1(XS34 spill )		
SP4	Main channel spill at B5 to reservoir 1		
SP5	Spill to and from reservoir 3		
SP6	Reservoir 1 spill back into main channel downstream of B5		

## 2.5 Scenarios Examined

The aims of the 2011 hydrological modelling study were to provide drainage advice and support to the SD2 Infrastructure design contractor with regard to the following:

- The height of a new flood protection berm along the eastern and north eastern margins of the SD2 Infrastructure area;
- The size of channels and culverts which comprise the subsidiary drainage system design;
- The design of the new access road and height and size of embankments and culverts, particularly proposed culvert 'B8' where the new access road crosses the third party pipeline corridor; and
- How to maximise flows through the western railway bridge 'B4' close to Sangachal Town in order to minimise outflows through the CPC bridge 'B3' with the aim of reducing the risk for the railway embankment to be flooded (which was noted in the WRA 2010 study).

## **3 Simulation Results**

### **3.1 Existing Terminal Flood Risk**

The first study (WRA, 2008a) was undertaken to check the capacity of the perimeter drainage channels for the existing Terminal, and determine the level of flood risk of the existing Terminal and associated facilities. The study concluded that the perimeter channels were adequate for a 100 year flood, even though they were designed for a 10 year event. The review confirmed that the Terminal was adequately protected from flooding through its existing configuration of perimeter drainage channels.

### **3.2 SD2 Infrastructure Project Hydrological Modelling**

Hydrological modelling for the SD2 Infrastructure Project involved an evaluation of the optimum design of new drainage infrastructure and the location and design height of access roads and embankments. A hydrological model was used (WRA, 2008b) to investigate the behaviour of low-lying storage area 'RES2' where runoff from Qaraqush catchments, northern catchments 'nw1' and 'nw2' and stormwater runoff from the Terminal all gathers. The 'RES2' storage area also receives flood waters that spill from the Shachkaiya Wadi channel at a number of low points along its left bank. Some of these spills flow back into the lower Shachkaiya Wadi system and flow out through bridge 'B4'. However, a significant portion of flow is intercepted by the third-party pipeline corridor system and diverted north eastwards into the low-lying 'RES2' storage area.

The modelling identified that this diversion of flood waters spilling out of the Shachkaiya Wadi channel into the 'RES2' storage area from a major flood event would result in over-topping of the railway along a 250m length above bridge 'B3'. Modelling results suggest that the extent of over-topping could be up to 0.7m over the ballast and 0.1m above rails, potentially causing damage through scouring (erosion) and failure of the railway embankment. The hydrological model indicated that flood risk is linked to the large catchment area upstream of the railway embankment. It is important to note that the impact of additional runoff from the Terminal and SD2 Infrastructure Project did not add to flood risk, with the additional runoff being barely noticeable in model results.

The existing flood risk to the railway was studied in detail by WRA in 2010. Possible solutions include improvements to a number of drainage routes which diverts flow from the Shachkaiya Wadi to the railway bridge 'B4' near Sangachal Town, thereby reducing flows into 'RES2' which later flows into 'B3'. Although drainage route improvements were proposed in an earlier study by URS (URS, 2003) and expanded upon by WRA (WRA, 2010), detailed modelling to identify the optimum configuration of drainage improvements was not undertaken.

#### **3.2.1 Modelling the New SD2 Access Road**

During hydrological modelling work for the new SD2 Infrastructure access road, a drainage problem was detected where a tributary of the Shachkaiya Wadi had been diverted to the south, towards the SD2 Infrastructure Area connected to construction of a local access road from Sangachal Town. It is possible that construction works were related to a haul road to be used for regional quarrying activities, although the purpose of the access road is not known. The drainage problem is caused by an

absence of a culvert constructed beneath the local access road which has resulted in the road embankment acting as a barrier to flow and subsequently diverts flood waters to the south. The drainage problem was identified from Google Earth images (refer to Figure 3.1) and later confirmed by the April 2010 field survey.

A proposed solution to this drainage problem involves extending the western flood protection berm (or embankment) to the north-east to meet the hillside base, to divert flood water south-west back into the natural channel (refer to Figure 3.1).



**Figure 3.1 Diversion of Wadi by Haul Road North of SD2 Infrastructure area**

Hydrological modelling indicated that culverts 'B7' and 'B8' (see Figure 1.3) can adequately convey flows beneath the SD2 access road resulting from a 1 in 100 year flood without causing localised flooding. A sensitivity analysis was undertaken on the total number of culverts used and their combined cross-sectional area, to determine how drainage flows are affected.

The sensitivity of the sizing of culvert 'B8' was assessed by varying the width of the five proposed box culverts to determine their optimal dimension. The peak flow levels at culvert 'B8' for different scenarios are listed in Table 3.1 where for each scenario, five box culverts 2.1m high with increasing width were tested along with different surface roughness values (referred to as Mannings 'n'). Results of the sensitivity analysis indicate that changes in culvert width have only a minor effect on peak flood levels.

Increases in surface roughness used to simulate the effects of greater numbers of smaller culverts which have the same, combined cross-sectional area, has no

apparent effect once the total culvert cross sectional exceeds 63m<sup>2</sup>. The lack of effect is linked to the large storage volume provided by 'RES1' and the gentle slope between 'RES1' and 'RES2' at culvert B8 which generates a moderate flow over the duration of the event, leading to a relatively low peak of 2.12 m<sup>3</sup>/sec for the major flood event.

**Table 3.1 Peak Levels at Culvert B8 Inlet for Different Scenarios**

Scenario	Peak Levels at Culvert B8 for 100 year 18 hour flood (m MSL)
3m culvert width	-18.914
6m culvert width	-18.938
9m culvert width*	-18.942
12m culvert width	-18.943
0.015 Mannings n*	-18.942
0.03 Mannings n	-18.942
* Initial estimates.	

Following a request from the SD2 Infrastructure design contractor an additional scenario was completed using the 10 year flood hydrographs which resulted in peak levels at culvert 'B8' being slightly lower at -18.952 m AOD for the five 9m culverts. Overall, the results indicate that there is no need to expand the current number and width of culverts included in the Base Case Design.

### 3.2.2 Flood Risk to the Railway at Central Drainage Bridge 'B3'

Hydrological modelling work that determined the optimum embankment height and size of culverts for the new SD2 access road indicated that new embankment will reduce existing high flood risk levels at the railway.

### 3.2.3 Flood Risk to the Coastal Highway at Culvert B6

The WRA reports of December 2008 (WRA, 2008b) and October 2010 (WRA, 2010) noted that the Coastal Highway culvert 'B6' located downstream of railway bridge 'B4' close to Sangachal Power Station, was at risk of flooding during the major flood event. Hydrological modelling undertaken in 2010 indicates that between 200m to 300m of the highway would be flooded in a major flood event, to a maximum depth of 0.05m to 0.10m. In this scenario, sediment-laden water would breach the road surface and cause physical damage to the highway. The exact location of the breach is difficult to predict due to the lack of detailed topographic survey data. The SD2 Infrastructure Project would not contribute in any significant way to the risk of nature of flooding at the highway.

The future risk of flooding to the Coastal Highway at culvert 'B6' from a major flood event will be slightly increased by the SD2 Infrastructure Project, as greater flows will be diverted from culvert 'B3' to 'B4' which ultimately flows into 'B6'. However, there will be a significantly reduced flood risk to the railway above bridge 'B3'. Following construction of the new SD2 access road, the access ramps to this route may provide a safe alternative route for traffic during such rare flood events. Consequently, the increased risk of culvert 'B6' overtopping and leading to flooding of the highway is offset by the alternative route provided by the new SD2 access road ramps during any major flood event.



### 3.2.4 Impact of Proposed Qizildas Cement Plant and Upstream Catchment Development

Construction of Qizildas Cement Plant which may include future quarrying activities for excavation of raw material upstream of the Shachkaiya Wadi catchment to the north of the Terminal, could be accompanied by similar industrial developments upstream. These activities have the potential to modify runoff volumes and reduce the response time of the catchment to rainfall events, reflected by lower 'Tp' values (i.e. the time to the peak of the unit hydrograph would shorten).

In order to investigate hydrological changes associated with development of Qizildas Cement Plant, the hydrological model was re-run with increased CN values (the relationship between rainfall and runoff) and reduced 'Tp' values to represent the potential changes linked to upstream developments of the main Shachkaiya Wadi catchment ('s1', 's2', 's3', 's4' and 's5' combined with runoff from 'Gz1', 'Gz2' and 'Gz3') and upper parts of the Cexamud tributary 's7'. The results indicate that peak runoff values from the major flood event increases from 60.9 m<sup>3</sup>/sec to 80.0 m<sup>3</sup>/sec for the Shachkaiya Wadi catchment, and from 22.8 m<sup>3</sup>/sec to 29.9 m<sup>3</sup>/sec. Total runoff values at 's7' (the Cexamud tributary) increases by 0.88 Mm<sup>3</sup>. Revised 10 year hydrographs are illustrated in Figure 3.4

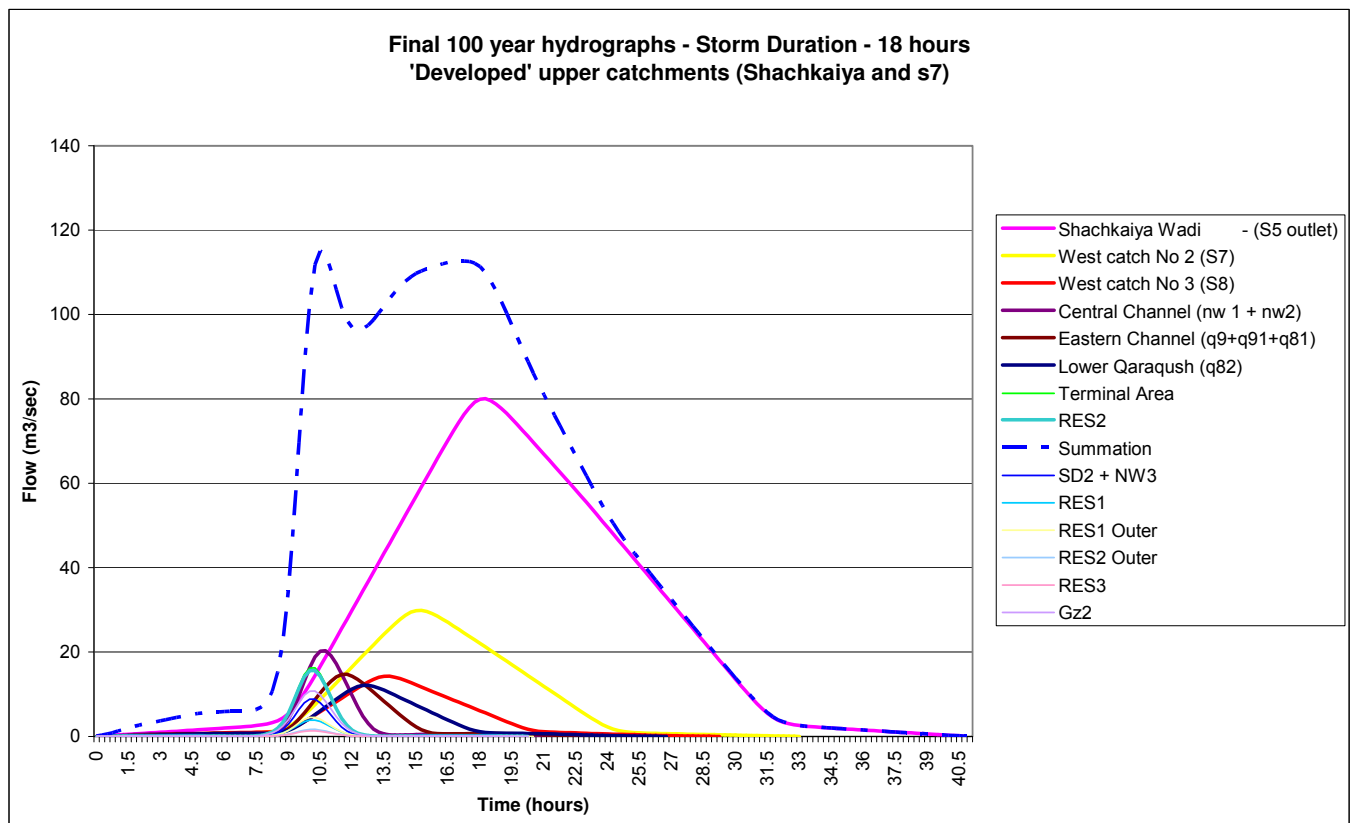

**Figure 3.2 100 year Hydrographs for Upstream Catchment Developments**

The impact from upstream developments upon critical locations are summarised in Table 3.2 and peak flood levels are stated with, and without, the upstream development.

**Table 3.2 Impacts of Upstream ‘Development’ on 100 Year 18 Hour Levels at Critical Locations**

Critical Location	100 Year Peak Flood Level (m) Without Development	100 Year Peak Flood Level (m) With Development
Culvert ‘B5’	-18.98	-17.55
Railway bridge ‘B4’	-20.95	-20.48
Coastal Highway culvert ‘B6’	-23.70	-23.14
Culvert B8 under new access road	-18.94	-18.94
Central railway bridge ‘B3’	-21.79	-21.79
Central Coastal Highway culvert ‘B9’	-23.27	-23.27

The results of hydrological modelling indicates that water levels from a major flood event will increase at bridges/culverts ‘B4’, ‘B5’ and ‘B6’ due to the direct effect of greater runoff. Impacts to bridges/culverts ‘B8’, ‘B3’ and ‘B9’ are not impacted which confirms that there are relatively low interflows between the main Shachkaiya Wadi system into central storage area ‘RES2’.

The predicted increase of 0.56m at Coastal Highway culvert ‘B6’ is likely to be an overestimate as limited survey data for the elevation of the highway elevations is available for this general area. The highway slopes away southwards at this location and water will be diverted out to the Caspian Sea along a significant stretch of road. Unfortunately, current survey data does not allow a reliable estimate of a change in flood level across the highway to be accurately determined.

## 4 Conclusions

Hydrological modelling undertaken by WRA during 2008 to 2011 focused on providing flood flows and flood elevation data to the SD2 Infrastructure design contractor. Such studies initially considered the capacity and effectiveness of the perimeter flood protection channels of the Terminal, then provided advice on road embankment heights and drainage culvert sizes for a number of alternative access road routes. The access route studies were undertaken in two stages, as route options were revised during design work for the SD2 Infrastructure Project.

Hydrological initial modelling demonstrated that the perimeter flood protection channels for the Terminal appeared to have been conservatively designed, and that they were capable of carrying flood waters up to, and including, the major flood event. Consequently, the Terminal can be considered to be safe in its current design, from water derived from catchments to the north and east.

The studies also demonstrate that the influence on local drainage patterns caused by presence of over-ground pipelines, unfilled trenches and spoil heaps along the third party pipeline corridor, which results in the diversion of over-bank spills from the Shachkaiya Wadi channel into ‘RES2’. The diversion of flows results in increased flood risk to the railway embankment, as the central drainage bridge beneath the railway ‘B3’ will be unable to pass flows during a major flood event and result in overtopping of the embankment. This type of flood event could lead to significant damage as flood waters would pass over the embankment at a height of 0.7m resulting in scouring and physical damage. The contribution of flood risk to the railway embankment that is associated with the SD2 Infrastructure Project was barely detectable in hydrological modelling.

The 2011 hydrological modelling demonstrated that construction of the new SD2

access road embankment will significantly reduce flood risk to the railway embankment as it will prevent flood waters associated with the Shachkaiya Wadi from entering 'RES2' which drains to the Caspian Sea via 'B3'.

The 2011 hydrological modelling confirmed the overall need for a western flood protection berm and supported the design in terms of its height and lateral extent. The results indicated that an embankment is only required at specific sections along its proposed length, due to the presence of existing topographic depressions. These findings have been incorporated into the Base Case Design. In addition, the western extent of the flood protection berm required extension to prevent water from a small tributary of the Shachkaiya Wadi to cause flooding to the northern part of the SD2 Infrastructure area. Following incorporation of these design changes into the Base Case Design, the SD2 Infrastructure area is considered to be protected from a major flood event.

The 2001 hydrological modelling demonstrated that existing bridge 'B4' beneath the railway east of Sangachal Town and Sangachal Power Station has sufficient capacity to cope with flood waters from a major flood event. However, culvert 'B6' under the Coastal Highway immediately downstream of 'B4' is not able to channel these flood waters, resulting in overtopping the highway to reach the Caspian Sea. The three concrete box section culverts at 'B6' have a combined cross-sectional area of 17.6m<sup>2</sup> which is significantly less than 'B4' which is 30.7m<sup>2</sup>.

The extent of flooding to the Coastal Highway cannot be predicted with a high level of certainty as there is not a complete set of topographical elevation data available for the road. Using available data, the hydrological model predicts that flood waters would impact a length of 300m up to 0.05 to 0.10m above the upper level of the road. Following construction of the new SD2 access road, the access ramps to this route would provide a safe alternative route for traffic during such flood events. The 2011 study also confirmed that Sangachal Town and Sangachal Power Station are sited on elevated ground and would be unaffected by a major flood event.

The 2011 Hydrological modelling results indicate that whilst the SD2 Infrastructure Project increases total runoff rates and volumes into the from the Shachkaiya Wadi, there are no increases in downstream flood or flood risk levels of more than 5mm at any of the key receptors included in the model. Key receptors were: Sangachal Town; Sangachal Power Station; the Caravanserai; the railway line; and the Coastal Highway.

Development of Qizildas Cement Plant (located approximately 4km north of the Terminal within the upper Shachkaiya Wadi catchment) and the associated access road and railway spur may have a significant impact on the flood risk and flood levels within lower reaches of the wadi. Details associated with the location, extent of quarrying activities and the exact position and width of the access roads are not available. Hydrological modelling using available data indicates that runoff could increase by up to 33 % from a major flood event. The development may increase existing flood levels at 'B4' by 0.47m and the Coastal Highway culvert 'B6' by up to 0.5m. Flood levels at 'RES2', 'B3' and 'B9' are not likely to be modified as the new SD2 access road embankment will protect this area from the effect of the increased flood runoff. There is however, some residual uncertainty associated with these predicted changes due to a combined lack of a ground elevation data, and absence of detailed information on the development.

Increased runoff flows from the Qizildas Cement Plant may have a significant effect



on flooding of the Caravanserai located immediately to the west of railway bridge 'B4'. Ground flood elevations at the State protected monument appear to be just above the major flood event level under existing conditions and after the SD2 Infrastructure Project. However, if the Qizildas Cement Plant were to be developed, then this key receptor could be flooded to a depth of over 0.45m. There are no significant changes to flood risk to Sangachal Town or Sangachal Power Station associated with this type of upstream development.

## 5 Bibliography

J V Sutcliffe, F A K Farquharson, E L Tate and S S Folwell, 2008. Flood regimes in the Southern Caucasus - the influence of precipitation on mean annual floods and frequency curves, Hydrology Research Vol 39 No 5–6 pp 385–401 © IWA Publishing 2008.

Kirpich Z. P., 1940. Time of concentration in small agricultural watersheds. Civil Engineering, 10 (6): 362.

NERC, 1975. Flood Studies Report, Natural Environment Research Council, London.

URS, 2003. 'AIOC Sangachal Terminal – Water management and landscape strategy', Final Report to BP Ltd. by URS, November 2003.

U.S. Soil Conservation Service, 1986. Technical Release 55: Urban Hydrology for Small Watersheds. USDA (U.S. Department of Agriculture).

WRA, 2008a. 'Sangachal Terminal – Surface and subsurface water and landscape management scoping study', Report for BP Ltd. by Water Resource Associates, April 2008.

WRA, 2008b. 'Sangachal Terminal Phase 2 Expansion – Surface Water Study', Stage 2 Final Report for BP Ltd. by Water Resource Associates, December 2008.

WRA, 2010. 'Sangachal Terminal Phase 2 Expansion – Additional Surface Water Studies', Final Report for BP Ltd. by Water Resource Associates, October 2010.

WRA, 2011. 'Sangachal Terminal Phase 2 Expansion – Hydrological and hydraulic modelling in support of detailed design for the flood protection & drainage works', Final Report for BP Ltd., by Water Resource Associates, June 2011.

## ANNEX 1 Details of ISIS Software

The ISIS hydrological modelling software used during the project is a commercial product developed in the UK jointly by one of the country's leading firms of consulting engineers, Halcrow Ltd. (see <http://www.halcrow.com/isis/default.asp>) and by the internationally renowned HR Wallingford Ltd., who were until the 1980s a UK Government funded hydrologic research laboratory but are now a private company. The software is now marketed and supported by Halcrow Ltd.

ISIS provides engineers, environmental scientists, planners and managers with a flexible and cost-effective range of tools for proactive decision making to help manage our environment. It is a suite of modular software solutions used for simulating water flow, hydrology, water quality changes and sediment transport in rivers, floodplains, canals, estuaries, catchments and urban areas. The version used for the study was the 1-D professional model, ISIS v3.4.

ISIS is suitable for a wide range of engineering and environmental applications, from calculating simple backwater profiles to modelling entire catchments. Applications include flood risk assessments, developing catchment management plans, flood alleviation scheme designs, river engineering and irrigation schemes, environmental impact assessments, water pollution management, flood risk mapping, integrated modelling, surface water management plans, catchment and floodplain development.

The ISIS suite of products is one of the leading software packages for river modelling and is used extensively throughout various countries around the world as an essential analysis tool for flood risk mapping, flood forecasting and many other aspects of flood risk management analysis. It has been used throughout the world by government bodies, environmental regulators, local authorities, water companies, drainage boards, insurance companies, universities and consultants.



### ***ISIS users around the world***

Clients include government bodies, environmental regulators, local authorities, drainage boards, universities and major river engineering consultants. Organisations that use the ISIS software include:

- AECOM
- AMEC
- ARDENT Consulting Engineers
- Atkins
- Black & Veatch
- British Waterways
- BRL Ingenierie
- Bureau Veritas UK Limited
- BURGEAP
- Buro Happold
- BWB Consulting Ltd
- Can Tho University
- Capita Symonds Ltd
- CARES Group
- CEDEX
- Civil Engineering Solutions
- Clarke Bond
- Cole Easdon Associates
- Cranfield University
- Create Consulting
- Dalglish Associates Ltd
- Deltares
- Edenvale Young
- Egniol Environmental
- Entec UK Ltd
- Environ UK Ltd
- Environment Agency
- Evans Rivers and Coastal
- Forestry Commission
- Golder Associates
- H2oK
- Halcrow Group Ltd
- Hannah - Reed
- Haskoning UK Ltd
- Heriot-Watt University
- Hyder Consulting
- Hydro-Logic
- J B Barry
- Jacobs
- JBA Consulting
- Lindsey Marsh Drainage Board
- Martin Wright Associates
- Mason Clark Associates
- Mekong River Commission Secretariat
- Ministry of Water Resources and Irrigation
- Mott MacDonald
- Mouchel Group
- MWH
- O'Connor Sutton Cronin & Associates
- Office of Public Works
- Ove Arup & Partners International Ltd
- Parsons Brinckerhoff Ltd
- Perth and Kinross Council
- Peter Brett Associates
- Pick Everard
- Pinnacle Consulting
- Scott Wilson Ltd
- SEPA
- Stuart Michael Associates
- Thames Water Utilities
- The City of Edinburgh Council
- Thomas Mackay Ltd
- TransTech Ltd
- UNESCO
- University of Aberdeen
- University of Bristol
- University of Cardiff
- University of Coventry
- University of Cranfield
- University of Glasgow
- University of Leeds
- University of Middlesex
- University of Newcastle
- University of Nottingham
- University of Plymouth
- University of Sheffield
- URS Corporation Ltd
- W A Fairhurst & Partners
- Weetwood
- West Oxfordshire District Council
- WSP Group
- WYG Engineering

In the UK the Environment Agency does not formally “approve” any model (the UK Government’s open policy). However ISIS is used routinely used in applications for the Environment Agencies in the UK and accepted by them as one of its limited range of hydrological modelling systems (the others being MIKE-11, InfoWorks and HEC-RAS). Its development was also supported by the Environment Agencies in UK. The three UK Environment Agencies: Environment Agency of England and Wales, Scottish Environmental Protection Agency and the Department of the Environment in Northern Ireland, are all users of ISIS.

Thus the software is one of the best available for the type of flood extent studied and use of the 1-D approach was deemed to be the most suitable option. A 1-D model treats the drainage system as a series of linked linear drainage channels whose properties are defined by a series of channel and flood plain cross sections. More complex 2-D models can make use of digital terrain models to understand better the flow routes that water will take during a flood. Unfortunately 2-D models are very input data intensive, requiring very high quality survey data for the entire study region, good quality hydrological inputs and more importantly, reliable historical data against which the model may be calibrated. Whilst the present study has good quality survey data for much of the area, the survey data does not extend far enough up the various wadi systems, local meteorological and hydrological data are limited, and there are no flow or level records available against which sophisticated 2-D models could be calibrated. Thus the choice of a 1-D ISIS model was believed to be the best option.

Any uncertainties in model results will stem from the limitations imposed upon the study by: the limited local historical rainfall and hydrological data available and; the absence of appropriate historical flood level or flood extent data against which model outputs could be validated.



## **APPENDIX 10A**

### **SD2 Infrastructure Project Activities, Events and Interactions - Socio-Economic**





### ACTIVITY/INTERACTIONS

ID (R=Routine, NR= Non- Routine)	Activity	Scoped In/Out	Reference	Event	Event Category
S1-R	Land Acquisition	x	-	Acquisition of land	Land Use and Access
S2-R	Disruption/access restrictions to natural resources and recreation	✓	5.5.2-5.5.6	Disruption/access restrictions to grazing land around terminal	
				Disruption/access restrictions to wetland area	
				Disruption/access restrictions to fishing areas	
S3-R	Employment creation	✓	5.9	Job creation	Employment
S4-R	Training and skills development	✓	5.9	Workforce training and skills development	Training and Skills Development
S5-R	Procurement of goods and services	✓	5.3	Increased economic flows	Procurement
S6-R	Operation of construction plant and vehicles onsite and offsite, movement of spoil, subsurface and above ground structural works and erection of buildings/structures - Community Disturbance (e.g. noise, dust)	x	-	Community disturbance (noise, vibration, dust, odour)	On-site and off-site construction plant and vehicles, topsoil and spoil movement, subsurface and above surface ground works and erection of buildings and structures
S7-R	Construction vehicle movements (offsite)	✓	-	Disruption to road users and community safety	Road and Rail
				Deterioration of public roads/highway	
S8-R	Road/railway closures and traffic works	✓	5.5.2-5.5.7	Disruption to road users Disruption to railway users	
S9-R	Connections to mains water supply - Disruption to freshwater supply	x	5.5.4	Disruption to fresh water supplies	Utilities
S10-R	Connections to mains power supply- Disruption to freshwater supply	x	5.5.2	Disruption to mains power supply	
S11-R	In-migration of workers resulting in increased pressure on community infrastructure (utilities, waste & sewage)	x	-	Disruption to freshwater supply	
				Disruption to mains power supply	
				Disruption to sewage network	
				Increased demand on municipal waste facilities	
S12-R	In-migration of workers resulting in increased pressure on community infrastructure (goods & services)	x	-	Increased demand for goods and services	Goods and Services
				Inflation in local prices for goods/services	
S13-R	In-migration of workers resulting in increased pressure on community infrastructure (employment)	x	-	Insufficient job creation	Employment
				Social tensions due to non-local employment & competition for jobs	
S14-R	In-migration of workers resulting in increased pressure on community infrastructure (health services)	x	-	Increased demand on local health services	Health
S15-R	De-manning	✓	5.9	Loss of jobs	De-manning

	Event Category	Event Magnitude			Probability	Receptor Sensitivity	Impact Significance
		Spatial Scope	Timing	Duration			
Socio-Economic	Disruption and access restrictions (SD2 Infrastructure Area)	Local	All SD2 Infrastructure area will be temporarily fenced during works to prevent unauthorised access.	Temporary	Highly likely	Local herders – high	<b>Moderate – major negative</b>
			Up to approximately 115 hectares will be permanently removed from use for herders.	Permanent			
	Disruption and access restrictions (Pipeline Landfall Area)	Local	The majority of the SD2 Infrastructure Area will be temporarily fenced during works (between March 2012 and June 2013).	Temporary	Highly likely	Recreational fishermen - Low	<b>Negligible</b>
					Highly likely	Commercial fishermen - Medium	<b>Negative</b>
					Highly likely	Recreational users - Low	<b>Negligible</b>
					Unlikely	Shoreline property - Low	<b>Negligible</b>
	Employment creation	Local	Employment will occur throughout the project, and is expected to peak between April 2012 and November 2012.	Temporary	Highly likely	Local community - High	<b>Moderate- Major Positive</b>
		Regional			Likely	Regional community – Medium	<b>Positive</b>
	Training and skills development	Local	Training will commence prior to the project activities and continue throughout the project.	Permanent	Highly likely	Local community – High	<b>Moderate-Major positive</b>
		Regional			Highly likely	Local community – Medium	<b>Positive</b>
	Procurement of goods and services	Local, and Regional	Procurement will take place throughout the project and benefits will cease shortly after the project finishes.	Temporary	Highly likely	Local and regional businesses - High	<b>Moderate- Major positive</b>
		National				National businesses - High	<b>Positive</b>
	Disruption and impact to community safety associated with construction vehicle movements (offsite)	Local	Off-site traffic movements will take place throughout the project.	Temporary	Unlikely	Road users and local community – High	<b>Negative</b>
Deterioration in Road Conditions	Local	Changes to road condition from the transportation of construction materials will take place throughout the project and will cease after the project finishes.	Temporary	Unlikely	Local Roads - High	<b>Negligible</b>	
					Main highway – Low	<b>Negligible</b>	
Road and rail works	Local, and regional	Road and rail works are expected throughout the project but disruption is expected to be of short duration.	Temporary	Highly likely	Local, regional and national businesses – High	<b>Negative</b>	
De-manning	Local	De-manning will likely commence prior to end of the project as manning levels decrease however it is expected that the main SD2 Project will provide relevant employment opportunities for workers	Permanent	Unlikely	Local community – High	<b>Negligible</b>	